

Simulation of the Effects of Backlash on the Performance of a Collaborative Robot: A Preliminary Case Study

Original

Simulation of the Effects of Backlash on the Performance of a Collaborative Robot: A Preliminary Case Study / Guida, R., Raviola, A., Migliore, D.F., De Martin, A., Mauro, S., Sorli, M.. - 120:(2022), pp. 28-35. (31st International Conference on Robotics in Alpe-Adria-Danube Region, RAAD 2022 Klagenfurt am Wörthersee (AUT) June 8-10, 2022) [10.1007/978-3-031-04870-8_4].

Availability:

This version is available at: 11583/2969441 since: 2022-07-04T17:22:28Z

Publisher:

Springer Science and Business Media B.V.

Published

DOI:10.1007/978-3-031-04870-8_4

Terms of use:

This article is made available under terms and conditions as specified in the corresponding bibliographic description in the repository

Publisher copyright

Springer postprint/Author's Accepted Manuscript (book chapters)

This is a post-peer-review, pre-copyedit version of a book chapter published in Mechanisms and Machine Science. The final authenticated version is available online at: http://dx.doi.org/10.1007/978-3-031-04870-8_4

(Article begins on next page)

Simulation of the Effects of Backlash on the Performance of a Collaborative Robot: A Preliminary Case Study

Roberto Guida^[0000-0002-7134-9635], Andrea Raviola^[0000-0001-9773-6089],
Domenico Fabio Migliore^[0000-0002-2934-7548], Andrea De Martin^[0000-0001-6714-631X],
Stefano Mauro^[0000-0001-8395-8297] and Massimo Sorli^[0000-0001-5163-9945]

Politecnico di Torino, Department of Mechanical and Aerospace Engineering,
Corso Duca degli Abruzzi 24, 10129, Torino, Italy
roberto.guida@polito.it

Abstract. The life cycle of industrial manipulators is heavily affected by wear due to continuous and repetitive movements the joints make. The consequent increase of backlash can jeopardize the correct execution of a task and, eventually, cause unexpected downtimes and economical losses. The present paper proposes a preliminary analysis of the effects of the presence of backlash between the motor and the joint shafts in a collaborative robot. To do so, different levels and locations of such fault have been simulated in a pick-and-place application using a dynamic model of a UR5 manipulator. The simulation results show how the deviations of the position of the tool center point from the desired trajectory highly depend on which joint presents a non-nominal behavior. The manuscript also introduces a methodology to detect the presence of backlash in industrial manipulators without any need for additional sensors. Besides the differences in the angular position measured by the motor (input) and the joint (output) encoders, spikes, whose magnitude depends on the backlash severity, arise in the motor currents. From these signals, a pool of health features candidates can be then extracted and considered for future applications in diagnostics and prognostics routines.

Keywords: Industrial Robots, Collaborative Robotics, High-Fidelity Modeling, Backlash, Health Management, Diagnostics.

1 Introduction

The level of automation within industrial companies has grown significantly in the last decade, driven in no small part by the increasingly widespread use of collaborative robots (cobots) [1]. Since any critical malfunctioning of these machines could lead to production wastes, unexpected downtimes, and economical losses, their correct health assessment is of primary importance. To do this, Data-Driven Models (DDMs) are used to extract health features from signals coming from the robot and other additional sensors to detect a fault at its early stage and optimize the maintenance procedures on the machine [2-3]. The drawback of this approach consists in its

need for large datasets of both healthy and degraded robots to properly detect and classify a faulty unit. However, since a robot mean time between failures is in the order of tens of thousands of hours [4], there is a shortage of data coming from robots operating in non-nominal conditions [5]. To overcome this problem, a possible solution is represented by the development of a High-Fidelity (HF) model of the manipulator in which to inject simulated faults and failures of different types and magnitudes. Signals generated by the robot simulation model would be representative of its behavior both in nominal and degraded operating conditions and could be fed to DDMs for health features selection. The feasibility of this approach has been proven in previous studies like [6], where a properly validated mathematical model of a robotic roller hemming device has been used to inform the machine learning routines used both for diagnostics and prognostics purposes. To do so, proper knowledge of the possible failure modes affecting both industrial and collaborative manipulators, and the effects on their performances, is crucial. In general, a robot is made up of three main macro-elements: the control unit, the teach pendant and the robotic arm. Except for accidental damages, the first two components are only subjected to electrical failures, which can be easily recognized by the built-in control logic. On the contrary, mechanical faults to the joints gearboxes, besides representing the most common failure mode in industrial robots [7], are less likely to be autonomously detected by the robot [8].

In this context, the present study provides a first insight into the effects of the presence of backlash between the input and the output shaft in a joint of a collaborative robot. Using a simulation model of a UR5 manipulator from Universal Robots, different levels and locations of backlash have been simulated and their effects on the Tool Center Point (TCP) position and motor currents have been quantified. The research campaign is a continuation of the work done in [9], where a UR5 multibody model has been developed in a MATLAB/Simulink environment and validated with experimental results.

2 Dynamic Model of a UR5 Collaborative Robot

To build a simulation model able to replicate the behavior of the real robot, it has been necessary to specify both the kinematic and dynamic properties of the manipulator and to properly tune the Proportional-Integrative (PI) parameters with which the joints control logic have been modeled. The Denavit-Hartenberg coefficients, used to build the robot kinematic chain, together with the values of mass and position of the center of mass of each joint/link, are provided by the manufacturer [10]. On the other hand, inertia tensors and joints friction have been identified according to the methodologies provided in [11] and [12], respectively. However, since not all the robot inertia parameters are identifiable, a mismatch among simulated and measured joints currents still persists. This issue will be addressed in future studies where the UR5 inertia tensors will be fully identified according to the methodology described in [13].

As for the real robot, the only input provided to the UR5 simulation model is the set of joints angular positions (q_{set}) required to perform the desired trajectory. All the other quantities (i.e., motor voltages, currents, joints angular velocities, and torques)

are internally calculated, for each one of the six joints of the manipulator, according to the joint scheme reported in Fig. 1.

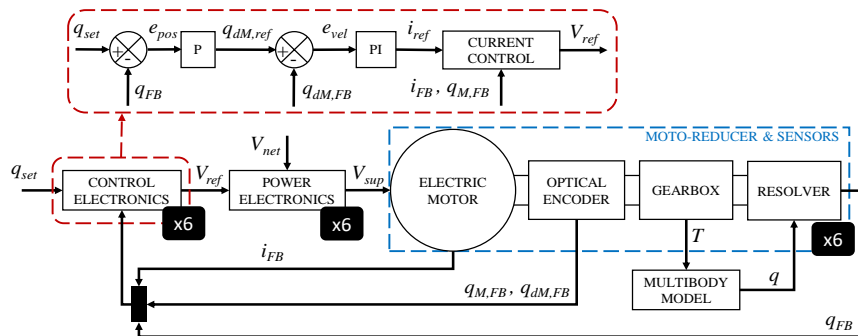

Fig. 1. Schematic representation of the dynamic model of the UR5 collaborative robot.

The control electronics has been structured in three nested control loops. The outermost ones are used to compensate the errors related to joints angular positions (e_{pos}) and the motor angular velocities (e_{vel}). On the other hand, the current control logic evaluates the reference voltage (V_{ref}) as a function of the reference (i_{ref}) and the feedback (i_{FB}) motor currents, and the motor angular position ($q_{M,FB}$). This information is sent to the power electronics that modulates the network voltage (V_{net}) to provide the electric motor the supply voltage (V_{sup}). Then, the gearbox model estimates the joint torque (T) taking into account friction losses. Torques are then given as input to the robot multibody model from which, through direct dynamics, joints angular positions (q) are determined and sent to the resolvers from which the feedback signals q_{FB} are obtained.

In case of a fault (i.e., backlash), the control logic will try to compensate the off-nominal behavior of the robot by minimizing the deviation of the actual joints positions from the nominal ones. As it will be better highlighted in section 3, the macroscopic effects of this drop in the manipulator performance will affect the TCP pose which is crucial, for the end user, for a proper completion of the assigned tasks.

2.1 Moto-reducers

To build a high-fidelity simulation model of a collaborative robot, detailed models of all its components should be developed. However, this would lead to high simulation times, so simplifications should be adopted. In the present research, only the shoulder joint has been modeled using a three-phase AC motor, while, for the other ones, simplified models of a DC brushless motor have been adopted. This choice has been driven by the fact that, according to [14], this is the joint with the highest stopping time.

The reduction of the motor speed, and the consequent increase in the joint torque, is achieved through a gearbox with a reduction ratio of 101:1.

The mechanical transmission is described through a damping-stiffness (c - k) model [15] so that the ideal output torque (T_{id}) is defined as:

$$T_{id} = \begin{cases} k\theta_{rel} + c\theta_{d,rel} & \text{if } \alpha = 0 \text{ (nobacklash)} \\ k(\theta_{rel} - \alpha) + c\theta_{d,rel} & \text{if } \theta_{rel} > \alpha \wedge k(\theta_{rel} - \alpha) + c\theta_{d,rel} > 0 \\ 0 & \text{if } \theta_{rel} > \alpha \wedge k(\theta_{rel} - \alpha) + c\theta_{d,rel} < 0 \\ k\theta_{rel} + c\theta_{d,rel} & \text{if } \theta_{rel} < 0 \wedge k\theta_{rel} + c\theta_{d,rel} < 0 \\ 0 & \text{if } \theta_{rel} < 0 \wedge k\theta_{rel} + c\theta_{d,rel} > 0 \\ 0 & \text{otherwise (nocontact)} \end{cases}, \quad (1)$$

being θ_{rel} and $\theta_{d,rel}$, respectively, the relative angular position and velocity of the gear teeth, and α the maximum clearance, expressed in radians, between them. However, due to the presence of friction within the joint, a friction torque (T_f) must be subtracted to T_{id} to obtain the actual torque (T) at the output shaft. This value is determined by an approximation of the Stribeck curve:

$$T_f = (T_{f,s} - T_{f,c})[1 - \tanh(10\omega)] + T_{f,c} + f_v \cdot \omega, \quad (2)$$

being $T_{f,s}$ and $T_{f,c}$, respectively, the static and the Coulomb friction torques, f_v the viscous friction coefficient, and ω the joint angular velocity at the output shaft. In the left image of Fig. 2, are depicted, for all the robot joints, the values of these contributions with respect to both the joint and motor angular velocities. For an accurate description of this phenomenon, the viscous friction coefficients are determined as a function of the joints temperature according to the findings reported in [16]. These are used to determine the experimental trends of the friction torques for the UR5 shoulder joint, reported in the right graph of Fig. 2, in a range of temperature likely to be encountered by a robot in an industrial environment.

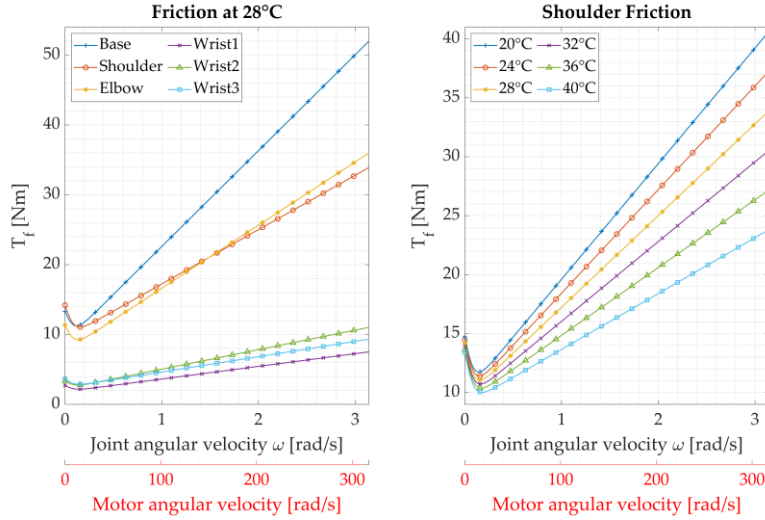

Fig. 2. Friction torques of the UR5 joints at 28 °C (left); Friction torque of the UR5 shoulder joint at different operating conditions (right).

2.2 Sensors

Before being used to close the relative control loops, the signals of the joint angular position, motor angular velocity, and current coming from the moto-reducers respectively pass through blocks used to simulate the presence of three sensors:

1. Resolver: a magnetic encoder, integral with the joint shaft, which measures the feedback angular position (q_{FB}) used to close the position control loop;
2. Optical encoder: mounted on the motor shaft to measure its angular position ($q_{M,FB}$) and velocity ($\dot{q}_{M,FB}$) used to close the motor speed control loop.
3. Current sensor: it measures the motor current (i_{FB}) used to close the relative loop.

First-order transfer functions have been adopted to simulate the current sensors, while second-order ones have been implemented for the two encoders. In addition, to replicate a real device, white noise, with the same standard deviation as the one of the signals measured from the UR5, has been added to the simulated quantities which have been then digitalized using a Sample and Hold circuit and a quantizer [9].

3 Simulations Results

Since, according to [17], robots are mainly used for handling tasks, it has been decided to study the effect of backlash on the UR5 TCP position during the pick-and-place of a 2 kg mass. The trajectory taken as a reference in this work is the second of the five ones described in [9] which have been designed to represent the movements usually performed by an anthropomorphic manipulator during such applications. As an example, in Fig. 3, are reported the deviations of the position of the TCP in case of a backlash α equal to 0.1° in different joints of a UR5 cobot.

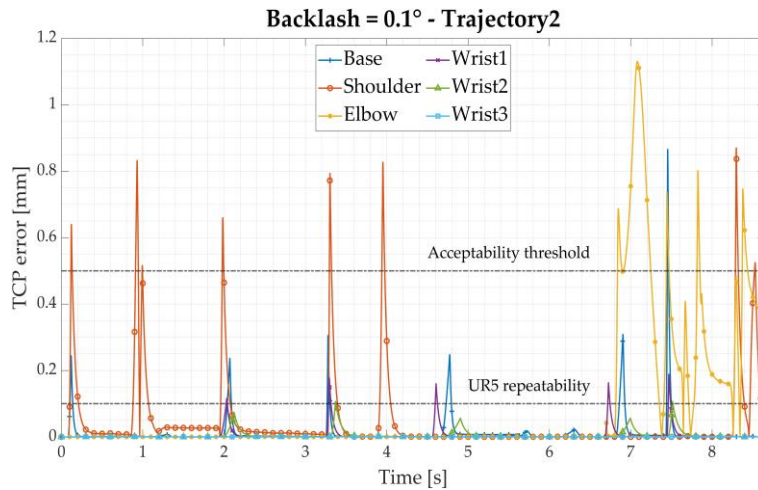

Fig. 3. Effects of backlash in different joints on the robot TCP position over the same pick-and-place trajectory.

Since the value of the backlash α over which Universal Robots manipulators autonomously detect a failure is not known, a trial-and-error approach has been used to detect such a threshold. Pick-and-place applications do not often require high accuracy in the positioning of an object. So, a maximum deviation of 0.5 mm, with respect to the nominal TCP position, has been labeled as not acceptable for the correct execution of the task. On the contrary, for other uses such as assembly or welding, which demand high precision movements, lower acceptability thresholds could be chosen. This information allows identifying the corresponding maximum acceptable level of backlash α , equal to 0.1° , which, as shown in Fig. 3, would lead to a deviation of the TCP position from the desired path higher than the above-mentioned limit.

From the simulations, it is possible to see that, for the proposed case study, the most critical joints are the ones of the base, the shoulder, and the elbow. This can be attributed to the fact that in general, for industrial manipulators, the wrist group is quite compact, while longer links connect the first three joints of a robot arm. So, each joint has a different impact on the proper position and orientation of the TCP, although similar results have been obtained in [9] for other trajectories.

Nevertheless, since the TCP pose derives from the forward kinematics applied to the joints angular positions, unless it is measured by external devices, it cannot be directly used to detect the presence of backlash in a robot arm. Instead, this can be done by comparing the measurements coming from the two encoders, mounted before and after the gearbox, integral with the motor and the joint shaft respectively. In the presence of backlash, there would be a mismatch between the two signals which will not be scaled only by the gear ratio. In addition, as reported in Fig. 4, current signals are also affected by the presence of such a fault and can be then used to detect an anomaly in the robot behavior.

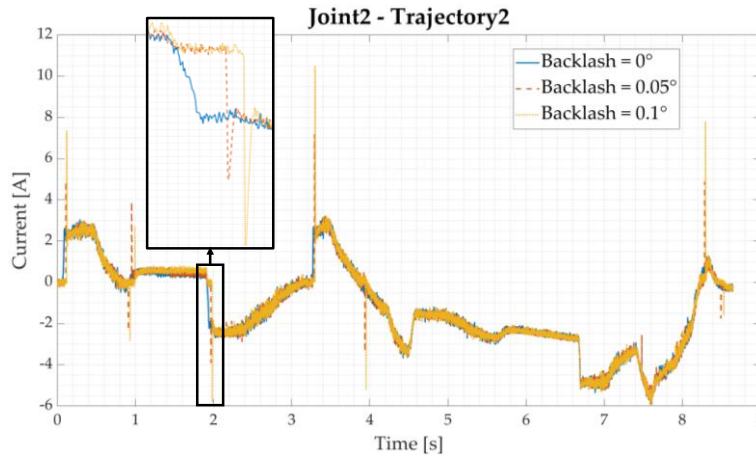

Fig. 4. Comparison of the effects of different levels of backlash on the motor current of the shoulder joint during a pick-and-place trajectory.

In the proposed case study, the analysis of the motor currents has been performed only in the case of a backlash on the shoulder joint. This choice has been driven by

the fact that, as already mentioned, this component is the only one in which the motor is modeled as a three-phase, as it actually is in the robot. In Fig. 4, it can be observed that, due to the presence of the backlash, whenever the sign of the quadrature current undergoes a variation, the transmitted torque is null for the time required to recover the clearance. This is due to the loss of contact among the gear teeth that can be caused by both a commanded inversion of the joint motion or by a change in the direction of the combined action of gravity and inertia forces. This leads to a mismatch between the reference and the feedback signals of the joint angular velocity which makes the current control loop command an increment, in absolute value, of the motor voltage to compensate such error, represented in Fig. 4 by the current spikes whose magnitude is correlated to the level of backlash.

4 Conclusions

The present paper provides a first insight into the macroscopic effects that the presence of backlash inside a joint of a collaborative manipulator can have on its overall performance. To do this, a mathematical model of a UR5 collaborative robot has been developed to study the deviations of the TCP positions and the motor currents from their nominal operating conditions in a pick-and-place application. Other typical robot tasks, such as welding, polishing, and drilling will be an object of future research.

For the proposed case study, simulation results suggest that the mismatch between joint angular positions measured by the two encoders and the spikes in the motor currents could be used as possible features candidates for studies aimed to assess the health status of an industrial robot.

Future work will be focused on the validation of the UR5 simulation model in non-nominal operating conditions. For more accurate results, the three-phase AC motor model will be extended to all the robot joints which will be also equipped with a more detailed model of the gearbox as the one introduced in [8]. An extensive simulation campaign will be then run to simulate the presence of other failure modes, both mechanical and electrical, in order to support data-driven algorithms for faults and failures identification, classification, and prognosis.

References

1. International Federation of Robotics: The Impact of Robots on Productivity, Employment and Jobs, International Federation of Robotics, Frankfurt, Germany (2017).
2. Jaber, A. A., Bicker, R.: Fault diagnosis of industrial robot gears based on discrete wavelet transform and artificial neural network, *Insight Non-Destructive Test. Cond. Monit.*, vol. 58, no. 4, pp. 179–186 (2016).
3. Jaber, A. A., Bicker, R.: Industrial robot backlash fault diagnosis based on discrete wavelet transform and artificial neural network, *Int. J. Progn. Heal. Manag.*, vol. 7, no. 2, (2016).
4. Majid, M. A. A., Fudzin, F. :Study on robots failures in automotive painting line, *ARPN J. Eng. Appl. Sci.*, vol. 12, no. 1, pp. 62–67 (2017).

5. Qiao, G., Weiss, B. A. Accuracy degradation analysis for industrial robot systems, in ASME 2017 12th International Manufacturing Science and Engineering Conference, MSEC 2017 collocated with the JSME/ASME 2017 6th International Conference on Materials and Processing, vol. 3, p. 9 (2017).
6. Grosso, L. A., De Martin, A., Jacazio, G., Sorli, M.: Development of data-driven PHM solutions for robot hemming in automotive production lines, *Int. J. Progn. Heal. Manag.*, vol. 11, no. January 2022 (2020).
7. Zhou, Q., Wang, Y., Jianming, X.: A Summary of Health Prognostics Methods for Industrial Robots, in 2019 Prognostics & System Health Management Conference - Qingdao, pp. 5–10 (2019).
8. Raviola, A., De Martin, A., Guida, R., Jacazio, G., Mauro, S., Sorli, M.: Harmonic Drive Gear Failures in Industrial Robots Applications : An Overview, pp. 350–360 (2021).
9. Migliore, D. F.: Modellazione e fault detection di giochi in robot collaborativi, Master's Thesis, Politecnico di Torino, Torino, Italy (2021).
10. Universal Robots A/S, Universal Robots - DH Parameters for calculations of kinematics and dynamics. <https://www.universal-robots.com/articles/ur/application-installation/dh-parameters-for-calculations-of-kinematics-and-dynamics/>, last accessed 18/01/2022.
11. Kufieta, K.: Force Estimation in Robotic Manipulators: Modeling, Simulation and Experiments, Norwegian University of Science and Technology, Master's Thesis, Trondheim, Norway (2014).
12. Raviola, A., De Martin, A., Guida, R., Pastorelli, S., Mauro, S., Sorli, M.: Identification of a UR5 collaborative robot dynamic parameters, vol. 102. (2021).
13. Bahloul, A., Tliba, S., Chitour, Y.: Dynamic Parameters Identification of an Industrial Robot: a constrained nonlinear WLS approach, 26th Mediterr. Conf. Control Autom., vol. 51, no. 15, pp. 443–448, (2018).
14. Universal Robots A/S, Universal Robots - What is CB3 Stop performance categories?, 2018. <https://www.universal-robots.com/articles/ur/safety/what-is-cb3-stop-performance-categories/>, last accessed 18/01/2022.
15. Akoto, C. L., Spangenberg, H.: Modeling of backlash in drivetrains, 4th CEAS Air Sp. Conf., no. September 2013 (2013).
16. Raviola, A., Guida, R., De Martin, A., Pastorelli, S., Mauro, S., Sorli, M.: Effects of temperature and mounting configuration on the dynamic parameters identification of industrial robots, *Robotics*, vol. 10, no. 3 (2021).
17. International Federation of Robotics, Presentation World Robotics press conference 2021, International Federation of Robotics, Frankfurt, Germany (2021)