

# Hourly Simulation of Energy Community with Photovoltaic Generator and Electric Vehicle

Angela Amato

*Dip. Energia "G. Ferraris"*  
*Politecnico di Torino*

Corso Duca Abruzzi 24, Torino, Italy  
angela.amato@polito.it

Alessandro Ciocia

*Dip. Energia "G. Ferraris"*  
*Politecnico di Torino*

Corso Duca Abruzzi 24, Torino, Italy  
alessandro.ciocia@polito.it

Enrica Garello

*Dip. Energia "G. Ferraris"*  
*Politecnico di Torino*

Corso Duca Abruzzi 24, Torino, Italy  
enrica.garello@studenti.polito.it

Gabriele Malgaroli

*Dip. Energia "G. Ferraris"*  
*Politecnico di Torino*

Corso Duca Abruzzi 24, Torino, Italy  
gabriele.malgaroli@polito.it

Filippo Spertino

*Dip. Energia "G. Ferraris"*  
*Politecnico di Torino*

Corso Duca Abruzzi 24, Torino, Italy  
filippo.spertino@polito.it

**Abstract**—Europe has set the ambitious goal to become the first carbon-neutral continent by 2050. Therefore, it has undertaken several initiatives to promote the energy transition, including the active participation of citizens in the energy sector. In this context, recent European directives introduced the concept of energy community, whose members can consume, share, and store energy locally produced. This work proposes an energy and economic simulation of a renewable energy community powered by a 19.2 kW<sub>p</sub> photovoltaic system in the province of Cuneo, in Piedmont (Italy). The community consists of a prosumer, which owns the photovoltaic system and a charging station for electric vehicles, and other 17 energy users. Suitable indicators to assess the energy performance of the community (self-consumption and self-sufficiency) were evaluated starting from the estimated production and consumption power profiles. Then, an economic simulation was carried out to assess the economic return on the investment for the member who bore the initial costs and the annual economic savings for the others.

**Keywords**—Energy communities, photovoltaic systems, self-consumption, self-sufficiency, net present value, payback time, internal rate of return.

## I. INTRODUCTION

The European Union (EU) aims to achieve the carbon neutrality by 2050 [1]. The energy sector, especially heat and electricity production, is the largest contributor to greenhouse gas emissions [2]. Therefore, policies to mitigate climate change must involve this sector, encouraging the transition from a fossil-based system to a system based on Renewable Energy Sources (RES). In this context, the most diffused and reliable RES technologies are PhotoVoltaic (PV) systems and wind turbines [3], [4]. To decarbonise the energy sector, the new policies promote the use of innovative technologies and mechanisms, engaging new players and radically transforming the traditional models for electricity generation, distribution and trade [5].

The EU has declared its intention to involve citizens in the energy transition with the Clean Energy for all Europeans Package. In particular, the recast of the Renewable Energy Directive (RED II) and the Electricity Directive define respectively the "Renewable Energy Communities" (REC) and the "Citizen Energy Communities" (CEC), whose members can carry out production, distribution, supply, sharing, storage, and sale of energy. The role of the citizen is therefore evolving from a passive consumer to an active player of the energy sector [6], [7].

Before issuing the above-mentioned Directives, several energy-related collective initiatives have already been launched in Europe, especially in the north-west area. These types of energy communities are very heterogeneous in terms of activities (generation, supply, consumption, sharing, distribution, electro-mobility, energy or financial services), energy technologies, organisational structure and ownership, size, membership motivations and socio-economic innovation. Not all these initiatives correspond entirely to the REC or CEC definitions, as they precede the Clean Energy Package [8].

Italy, on the other hand, has not extensive experience with energy communities. Existing initiatives are mainly historical electric cooperatives and consortia created before 1962, when the nationalization of the electricity sector occurred. The contents of the RED II on energy communities have been transposed by art. 42-bis of Decree-Law No. 162 of 30 December 2019, converted into Law No. 8 of 28 February 2020. The main features of the transposition concern the rated power of the community's renewable energy plants, the perimeter of the community, and the energy exchange model. The energy production plants of the community must have a total rated power not exceeding 200 kW and be connected to the electricity grid through the same medium/low voltage substation from which the community withdraws grid energy. The existing distribution grid is used for the energy exchanges within the community (virtual exchange model), allowing each energy user to maintain its own grid connection point. Energy communities are supported by an incentive on the energy shared within the community, assessed on an hourly basis as the minimum between the electricity produced and fed into the grid by the RES plants and the electricity withdrawn by all the customers involved in the community [9]. However, Law No. 8 of 2020 was a transitional transposition. The RED II has been definitively transposed by Legislative Decree No. 199 of 8 November 2021. The significant novelties introduced by the final transposition relate the increase in the admissible rated power for the generation plants (up to 1 MW) and the extension of the perimeter (from medium/low voltage substation to the high/medium voltage one) [10].

This article presents an energy and economic simulation of a REC set up in the province of Cuneo (Piedmont, Italy). The community has been created in the transitional phase, according to the guidelines prescribed by Law No. 8 of 2020 and

summarized above. It consists of residential and tertiary-sector energy users, with different load profiles in terms of power demand and peak demand hours. It is equipped with a 19.2 kW PV system, owned by a member of the community (the prosumer). The PV energy is directly consumed by a private charging station for electric vehicles that belongs to the prosumer. The remaining amount of energy locally produced is shared among the other community members.

The paper is organised as follows: in Section II the methodology applied to perform the energy community simulation is presented. In Section III the energy and economic indicators considered suitable for assessing the performance of the REC are defined. Section IV describes the case study. Section IV presents the energy and economic results. Finally, Section V contains the conclusions.

## II. DESCRIPTION OF THE METHOD

The proposed method has been applied to carry out an energy and economic simulation of the REC under study. However, its application can be useful to assess the performance of any energy community including prosumers powered by PV energy. The methodology (flowchart in Fig. 1) can be summarized in the following steps:

- Step A - Estimation of hourly PV production profile: the hourly production profile of the PV system is obtained thanks to the software Photovoltaic Geographical Information System (PVGIS) [11]. It provides the DC power  $P_{PV}$  as a function of the irradiance  $G$ , and the cell temperature  $T_c$ . Data regarding these parameters are values of a reference year, evaluated over the period 2005-2016. Then, the AC production is assessed as follows [12]:

$$P_{AC\ gen} = P_{PV}(G, T_c) \cdot \eta_{array} \cdot \eta_{PCU} \quad (1)$$

where  $\eta_{PCU}$  is an efficiency taking into account losses due to Maximum Power Point (MPP) tracking, DC/DC and DC/AC conversion. On the contrary, the quantity  $\eta_{array}$  includes typical PV losses due to dirt, reflection from the glass,  $I$ - $V$  mismatch, and Joule effect in the cables [13]. Obviously, AC production depends on the main information about the system: the installation site, the rated power, the technical specifications of its components (PV modules, inverters, cables), the tilt and azimuth angles of the modules, the type of installation (building-integrated or ground-mounted), and the presence of obstacles.

- Step B - Estimation of hourly load profiles: the hourly load profiles of the community members are measured data, provided through electricity bills or by the distribution system operator for a reference year. Regarding the charging station, its load profile is not measured but it is estimated by making some assumptions on the electricity withdrawn by the prosumer's electric vehicle, as only this car has access to the station. The assumptions include the vehicle consumption and the capacity, the charging efficiency and the minimum state of charge of its battery.

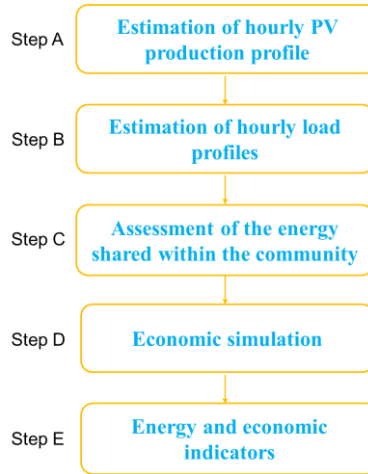

Fig. 1. Scheme of the methodology.

- Step C - Assessment of the energy shared within the community: after evaluating the hourly production and load profiles, it is possible to calculate the amount of shared energy ( $E_{shared}$ ) in the time interval  $\Delta t$ , according to (2):

$$E_{shared}(\Delta t) = \min(E_{inj}(\Delta t); E_{with}(\Delta t)) \quad (2)$$

$$\text{with } E_{inj}(\Delta t) = E_{PV}(\Delta t) - E_{pros}(\Delta t),$$

where  $E_{with}$  is the electricity withdrawn by all consumers belonging to the community: this term is the sum of the consumption of each user, excluding the prosumer. On the contrary,  $E_{inj}$  is the electricity generated and fed into the grid by the PV plant. This quantity is the difference between the energy produced by the PV system ( $E_{PV}$ ) and the energy withdrawn by the prosumer ( $E_{pros}$ ). Fig. 2 highlights all the energy flows involved in the calculation of  $E_{shared}$ . The time interval  $\Delta t$  is established by regulation and it is equal to 1 h [9].

- Step D - Economic simulation: to carry out the economic simulation, the investment and operation costs, as well as the expected revenues, must be known. Discounted Cash Flow (DCF) analysis can be used to evaluate the economic return on the investment for the community member who bore the investment cost. On the other hand, for the energy users who joined the community without having incurred any investment costs, it is possible to estimate the expected savings.

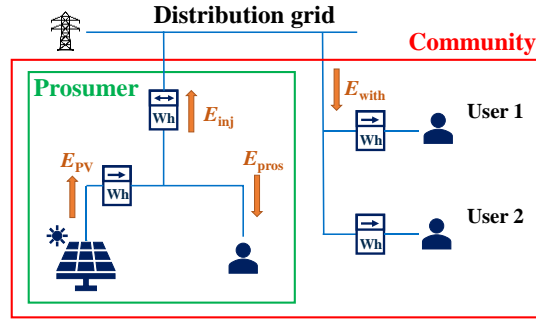

Fig. 2. REC scheme with energy flows relevant to the calculation of  $E_{shared}$  in evidence.

- Step E - Evaluation of energy and economic indicators: to analyse the energy and economic simulation results, suitable indicators are used. For the energy simulation, Self-Consumption ( $SC$ ) and Self-Sufficiency ( $SS$ ) are considered appropriate in the context of energy communities. On the other hand, for the economic simulation, the Net Present Value ( $NPV$ ), the PayBack Time ( $PBT$ ) and the Internal Rate of Return ( $IRR$ ) are evaluated for the investor. For the community members who have not incurred any costs, an annual bill saving is calculated. The indicators mentioned are defined in Section III.

### III. ENERGY AND ECONOMIC INDICATORS

#### A. Energy indicators

Self-consumption, as expressed in (3), is defined as the ratio between the locally generated and consumed energy ( $E_{lgc}$ ) in the time interval  $\Delta t$  and the total energy generated by the PV system ( $E_{PV}$ ) in the same time interval [14]. In each  $\Delta t$ , the  $E_{lgc}$  is the minimum between generation ( $E_{PV}$ ) and load ( $E_{load}$ ):

$$SC = E_{lgc}(\Delta t) / E_{PV}(\Delta t) \quad (3)$$

$$\text{with } E_{lgc}(\Delta t) = \min(E_{PV}(\Delta t); E_{load}(\Delta t)).$$

Self-sufficiency is the ratio of locally generated and consumed energy ( $E_{lgc}$ ) to the total energy consumed ( $E_{load}$ ) in the time interval  $\Delta t$ , as expressed in (4):

$$SS = E_{lgc}(\Delta t) / E_{load}(\Delta t). \quad (4)$$

A high value for both  $SC$  and  $SS$  means a good matching between generation and load profiles [15].

#### B. Economic indicators

The  $NPV$  of a project, defined by (5), is the algebraic sum of the Investment Cost ( $IC$ ) and the operation cash flows ( $R_t$ ), discounted at the rate values  $i$  and generated in the  $t^{\text{th}}$  year [16]:

$$NPV = -IC + \sum_{t=1}^n R_t / (1 + i)^t. \quad (5)$$

A profitable project has an  $NPV$  greater than zero.

The  $IRR$  is the discount rate that makes the  $NPV$  equal to zero, as expressed in (6):

$$-IC + \sum_{t=1}^n R_t / (1 + IRR)^t = 0. \quad (6)$$

According to [17], the  $IRR$  for renewable energy projects is about 8-9%. However, European solar projects have an average  $IRR$  of 4%.

The  $PBT$  is the time required to recover the investment thanks to the operation cash flows generated by the project. At the  $PBT$ , the cumulative cash flow equals zero.

The legislation establishes that RECs can receive an incentive and a refund of system charges on shared energy, and a revenue for selling the surplus electricity to the grid. The distribution of the income among the members of the community is regulated by an internal agreement. For example, for the REC under study, revenues will be divided as shown in Fig. 3.

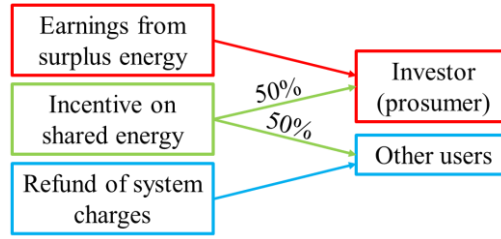

Fig. 3. Distribution of earnings in the REC under study.

For the  $j^{\text{th}}$  energy user who did not participate in the investment, the economic benefit is quantified through the annual percentage saving on the electricity bills ( $S_{\%,j}$ ), defined by (7):

$$S_{\%,j} = \frac{R_{\text{tot},j}}{B_j} \cdot 100 \quad (7)$$

where  $R_{\text{tot},j}$  is the yearly refund that the  $j^{\text{th}}$  user is entitled to receive from the community and  $B_j$  is the annual electricity expense for the  $j^{\text{th}}$  user. The quantity  $R_{\text{tot},j}$  is the sum of the refund of system charges ( $C_{\text{sys},j}$ ) and the incentive ( $I_j$ ), which are evaluated according to (8):

$$R_{\text{tot},j} = C_{\text{sys},j} + I_j \quad (8)$$

$$\text{with } C_{\text{sys},j} = E_{\text{shared},j} \cdot CU_{\text{Af},m}$$

$$\text{and } I_j = f_1 \cdot I_{\text{tot}} \cdot E_{\text{shared},j} / E_{\text{shared,tot}}$$

where  $E_{\text{shared},j}$  is the annual local renewable energy consumed by the  $j^{\text{th}}$  user.  $CU_{\text{Af},m}$  is the chargeback per unit of energy, calculated as specified in [18] and assumed equal to 8 €/MWh, and  $I_{\text{tot}}$  is the total incentive on the shared energy received by the community. The parameter  $f_1$  is the allocation factor of  $I_{\text{tot}}$  between the prosumer and the other members; in the case study presented in this work, it is equal to 0.5 (i.e., the incentive is equally partitioned) as indicated in Fig. 3. Finally,  $E_{\text{shared,tot}}$  is the total energy shared in the community. Regarding the incentive on shared energy, the revenue for the community is 110 €/MWh [19].

Obviously, the key point of the energy community is the share of the surplus from the local producers. Nevertheless, the criterion to divide the local energy surplus between members has to be defined, determining each quota  $E_{\text{shared},j}$ . The energy is shared as follows:

- Case #1 - the entire local production is higher than the whole community load: all the loads are supplied, and surplus is used for loads external to the community.
- Case #2 - the entire local production is lower than the whole community load: in this case, the local surplus of the prosumer  $E_{\text{inj}}$  has to be divided between the other members. Each quota is weighted with the ratio between the user's consumption  $E_{\text{load},j}$  and the whole community consumption  $E_{\text{load,tot}}$ , as defined by (9):

$$E_{\text{shared},j} = E_{\text{inj}} \cdot (E_{\text{load},j} / E_{\text{load,tot}}). \quad (9)$$

For example, as shown in Fig. 4, the surplus from the prosumer is 10 kW, while the whole consumption from the other users is 12 kW. The first user will account for a local energy production of  $\approx 6.7$  kW, while the remaining 1.3 kW is provided by the external grid. In the same way, user 2 will account for  $\approx 3.3$  kW from the local generator; 0.7 kW is provided by the external grid.

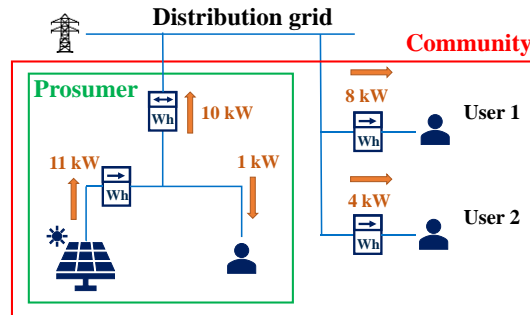

Fig. 4. Example of energy sharing within a community (Case #2).

## IV. RESULTS OF THE CASE STUDY

### A. Description of the case study

The above-described methodology was applied to a REC built in July 2021 and located in the province of Cuneo (Piedmont, Italy). The community members are a prosumer that owns a 19.2 kW PV system and a 22-kW charging station for electric vehicles, a gym, and 16 users within the same apartment building – 11 residential users, 3 PODs (Points of Delivery) for energy use in shared spaces, an office, and a language school. Regarding the PV system, it consists of 60 monocrystalline silicon modules with a rated power of 320 W. They are installed on the gym roof, south oriented with a tilt angle of  $6^\circ$ . As shown in the Fig. 5, the charging station is connected downstream of the exchange meter (M1). Therefore, it is the only load in direct self-consumption. Indeed, the other users self-consume PV energy in virtual mode through the existing distribution grid (i.e., PV energy is fed into the grid and then absorbed by the users).

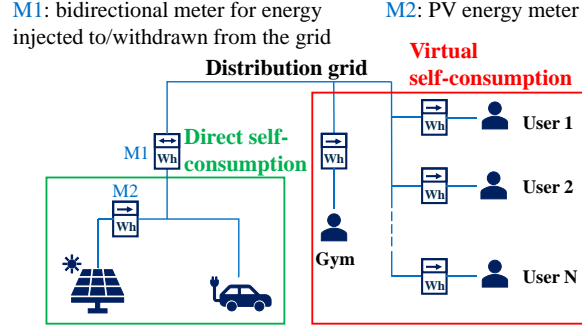

Fig. 5. Scheme of the energy community under study.

### B. Energy simulation results

In this work, the quantities  $\eta_{PCU}$  and  $\eta_{array}$  are assumed equal to 98% and 92%, respectively. Fig. 6 displays the monthly PV energy production for the site under analysis, while Tab. I reports the main yearly results of the PV generator.

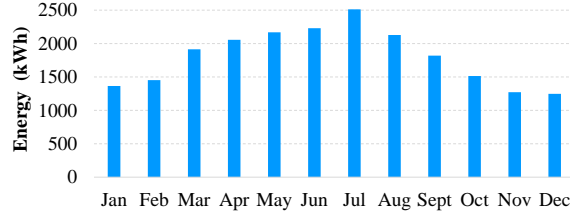

Fig. 6. Monthly PV energy production.

TABLE I. ESTIMATED PRODUCTION OF THE PV SYSTEM

<b>Yearly irradiation</b>	1253 kWh/m <sup>2</sup>
<b>Yearly specific production</b>	1021 kWh/kW <sub>p</sub>
<b>Yearly production</b>	19621 kWh

Considering the geographical position of the site, the specific PV production may be higher with different installation specifications. Actually, the inclination angle of the modules is lower than the optimal value and the performance is lowered due to shading caused by the surrounding buildings in winter months.

Regarding the hourly load profiles, the consumption of the charging station for electric vehicles was determined starting from the assumptions for the quantities mentioned in Section II. To obtain the load profile of the charging station, the prosumer's vehicle is assumed to be charged exclusively at this station, and it is the only car using the station. Data regarding the vehicle consumption and the battery capacity were obtained selecting average market values [20]. In particular, an energy capacity of 44 kWh and a consumption of 0.15 kWh/km were assumed. Moreover, an annual travelled distance of 12000 km was estimated, being the average value of the distance travelled by drivers in Piedmont [21]. Finally, it was assumed a charging efficiency of 90% and the battery life was preserved by not discharging it below 20% of its nominal capacity. Under these assumptions, the annual demand of the electric vehicle is 1824 kWh, leading to an energy absorption of  $\approx 2027$  kWh from the charging station. Thus, in the simulation the vehicle was charged once a week, i.e., every Sunday starting at midday.

On the contrary, the electricity consumptions of the other REC members were extrapolated from a reference year. Actually, the electricity bills for 2019, combined with data from the distribution system operator, allowed to obtain hourly load profiles for 12 months and to estimate the PV energy consumed by each user ( $E_{shared,j}$ ). Tab. II shows the annual consumption and  $E_{shared,j}$  values of the community members, excluding the prosumer.

TABLE II. YEARLY ENERGY CONSUMPTION AND SHARED ENERGY

Users	Yearly energy consumption (kWh)	$E_{\text{shared},j}$ (kWh)
Residential user #1	1550	395
Residential user #2	1156	301
Residential user #3	1418	366
Residential user #4	2341	581
Residential user #5	3141	900
Residential user #6	1839	485
Residential user #7	2164	609
Residential user #8	2015	490
Residential user #9	1340	385
Residential user #10	208	56
Residential user #11	465	123
POD #1	1052	323
POD #2	1393	435
POD #3	3948	882
Office	1851	747
Language school	4279	1347
Gym	13890	5448
<b>Total</b>	<b>44049</b>	<b>13873</b>

C. Economic simulation results

As far as the economic simulation is concerned, investment costs, operation costs and revenues were quantified for the prosumer who bore the initial costs. With these input data, the DCF analysis was carried out over a 20-year period, which corresponds to the incentive period of shared energy in energy communities. The prosumer's investment ( $\approx 15000$  €) includes the costs for the PV system, the charging station, and the grid connection. In addition, the prosumer will bear the operational costs of the plant ( $\approx 330$  €/year). The community management cost ( $\approx 800$  €/year) will be shared between the prosumer and the other members; this cost will be deducted from the income due to the incentive on shared energy. As shown in Fig. 3, the revenues include the valorisation of the energy fed into the grid at the market price entitled to the prosumer ( $\approx 1000$  €/year), the incentive on shared energy ( $\approx 720$  €/year, net of management costs) spread among the members of the community, the refund of system charges ( $\approx 110$  €/year) entitled to users who self-consume in virtual mode. In addition, the DCF analysis took into account the savings for the prosumer generated by the use of the private charging station instead of a public one ( $\approx 765$  €/year).

D. Energy and economic indicators

The PV system under study is oversized for the prosumer: actually, 83% of the PV energy may not be consumed by the prosumer. About 13.9 MWh of surplus PV energy for the prosumer could be used within the REC. The gym and the office, characterised by a high consumption in the middle hours of the day, could meet about 40% of their yearly consumption using PV energy. The language school, on the other hand, could supply only 31% of its energy demand, because its consumption is high in winter when PV generation is low. For residential users and shared services (POD #1, #2 and #3), the percentage of load satisfied by PV energy may reach a value between 22% and 31%. Regarding the charging station (i.e., the prosumer), most of the required electricity to charge the car is supplied by PV energy ( $\approx 69\%$ ). On the other hand, its self-consumption on annual basis is low ( $\approx 7\%$ ).

Tab. III shows the annual values of *SC* and *SS*. For the prosumer, the values refer to direct self-consumption, while for the other users they refer to virtual self-consumption through the existing distribution grid. The results in the table confirm that the PV system is oversized for the prosumer (low *SC*, high *SS*), but undersized for the whole community (high *SC*, low *SS*).

Fig. 7 shows the results of the DCF analysis over the investment lifetime. Although a discount rate *i* of 4% can be assumed for this type of investment, scenarios with *i* = 2% and *i* = 6% were also considered. In all three scenarios, the *NPV* at 20 years is positive (higher for the lower *i*). It reaches  $\approx 13500$  € with *i* = 2%,  $\approx 8700$  € with *i* = 4% and  $\approx 5000$  € with *i* = 6%.

TABLE III. ANNUAL SELF-CONSUMPTION AND SELF-SUFFICIENCY

Users	<i>SC</i>	<i>SS</i>
Prosumer	7%	69%
Other users	71%	31%
REC	78%	33%

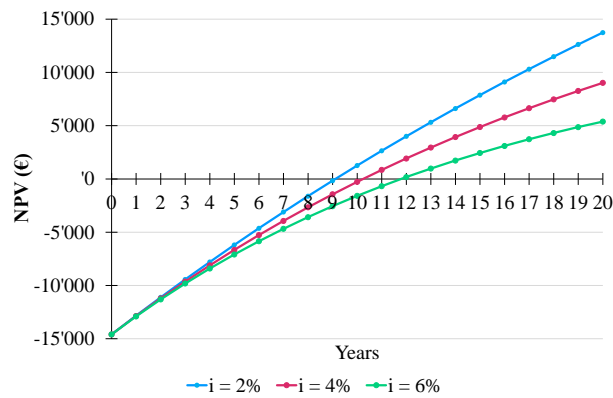

Fig. 7. DCFs with three discount rate values.

However, the investment is recovered in the first half of the incentive period ( $PBT \approx 9$  years) only for  $i = 2\%$ . In the other two cases, the investment is recovered in more than 10 years (discount rate of 4%) and almost 12 years (rate of 6%). The  $IRR$  of the investment was estimated at 10.3%.

Finally, the average bill saving for community members who did not participate in the investment was estimated at 3.2%. The highest saving can be achieved by residential user 5 ( $S_{\%,j} = 4.9\%$ ), while the lowest bill reduction is for residential user 11 ( $S_{\%,j} = 1.1\%$ ).

## V. CONCLUSIONS

This work proposes an energy and economic simulation of an energy community in Piedmont, in which a prosumer, that owns a 19.2 kW PhotoVoltaic (PV) system and a charging station for electric vehicles, shares its surplus with 17 other members. The methodology used to perform this simulation can be applied to any energy community including prosumers with PV generators. Regarding the hourly production profiles, the PV energy was estimated at 19.6 MWh/year. The prosumer's demand, evaluated at 1.8 MWh/year, results in a direct  $SC$  of 7% and a  $SS$  of 69%. Based on historical data, the total load of the other community members was estimated equal to 44 MWh/year, of which 13.9 MWh/year can be supplied by the PV system. This corresponds to a  $SC$  of 71% and a  $SS$  of 31% by the community, excluding the prosumer. The energy results demonstrate the effectiveness of the community: considering the entire REC,  $SC$  and  $SS$  are estimated equal to 78% and 33%, respectively. Moreover, the low level of self-sufficiency, combined with the high self-consumption level, demonstrates that the considered generator is undersized, and additional generation and storage could be profitably included in the community.

Regarding the financial parameters, a Discount Cash Flow analysis was performed, assuming three discount rate values (2%, 4% and 6%). The  $NPV$  and  $PBT$  depend on the discount rate value. The  $NPV$  at 20 years is positive with all three rates considered, reaching 13500 € with the lowest one. The  $PBT$  varies between  $\approx 9$  ( $i = 2\%$ ) and  $\approx 12$  years ( $i = 6\%$ ). The  $IRR$  is 10.3%. For the members who did not bear the investment, the advantages of participating in the community are two. The first is a modest economic benefit quantified as annual saving in the bill, with an average value of  $\approx 3\%$ . The second benefit is the use of locally produced renewable energy without additional costs.

Future works will investigate the effect of increasing the installed PV power, in order to maximize both self-sufficiency and self-consumption. Finally, the impact of different usage patterns of the electric vehicles will be considered to study the effects on the self-sufficiency of the whole community.

## REFERENCES

- [1] European Commission, "A European Green Deal". Available online: [https://ec.europa.eu/info/strategy/priorities-2019-2024/european-green-deal\\_en](https://ec.europa.eu/info/strategy/priorities-2019-2024/european-green-deal_en) (accessed Jan. 12, 2022).
- [2] IEA, 'Climate change'. Available online: <https://www.iea.org/topics/climate-change> (accessed Jan. 12, 2022).
- [3] F. Spertino, A. Amato, G. Casali, A. Ciocia, and G. Malgaroli, "Reliability analysis and repair activity for the components of 350 kW inverters in a large scale grid-connected photovoltaic system", *Electronics*, vol. 10, no. 5, pp. 1–13, 2021, doi: 10.3390/electronics10050564.
- [4] A. Carullo, A. Ciocia, G. Malgaroli, F. Spertino, "An innovative correction method of wind speed for efficiency evaluation of wind turbines," (2021) *Acta IMEKO*, 10 (2), pp. 46 – 53, doi 10.21014/acta\_imeko.v10i2.1037.
- [5] A. Berka and M. Dreyfus, "Decentralisation and inclusivity in the energy sector: Preconditions, impacts and avenues for further research", *Renew. Sustain. Energy Rev.*, vol. 138, 2021, doi: 10.1016/j.rser.2020.110663.
- [6] European Commission, "Directive (EU) 2018/2001 of the European Parliament and of the Council of 11 December 2018 on the promotion of the use of energy from renewable sources", *Official Journal of the European Union*, vol. 2001, no. December. pp. 82–209, 2018.
- [7] European Commission, "Directive (EU) 2019/944 of the European Parliament and of the Council of 5 June 2019 on common rules for the internal market for electricity and amending Directive 2012/27/EU", *Official Journal of the European Union*, vol. 62. pp. 125–199, 2019.
- [8] A. Caramizaru and A. Uihlein, "Energy communities: an overview of energy and social innovation", 2019. doi: 10.2760/180576.
- [9] Presidente della Repubblica, "Legge 28 febbraio 2020, n. 8". Available online: <https://www.gazzettaufficiale.it/eli/id/2020/02/29/20G00021/sg> (accessed Feb. 28, 2022), Italian language.
- [10] Presidente della Repubblica, "Decreto Legislativo 8 novembre 2021, n. 199". Available online: <https://www.gazzettaufficiale.it/eli/id/2021/11/30/21G00214/sg> (accessed Feb. 28, 2022), Italian language.

- [11] “JRC Photovoltaic Geographical Information System (PVGIS) - European Commission”. Available online: [https://re.jrc.ec.europa.eu/pvg\\_tools/en/](https://re.jrc.ec.europa.eu/pvg_tools/en/) (accessed Feb. 25, 2022).
- [12] P. Di Leo, F. Spertino, S. Fichera, G. Malgaroli, and A. Ratclif, “Improvement of self-sufficiency for an innovative nearly zero energy building by photovoltaic generators”, in 2019 IEEE Milan PowerTech, 2019, pp. 1-6, doi: 10.1109/PTC.2019.8810434.
- [13] G. Chicco, V. Cocina, P. Di Leo, F. Spertino, and A. Massi Pavan, “Error assessment of solar irradiance forecasts and AC power from energy conversion model in grid-Connected photovoltaic systems”, *Energies*, vol. 9, no. 1, p. 8, Dec. 2016, doi: 10.3390/en9010008.
- [14] F. Spertino, S. Fichera, A. Ciocia, G. Malgaroli, P. Di Leo, and A. Ratclif, “Toward the complete self-sufficiency of an NZEBS microgrid by photovoltaic generators and heat pumps: Methods and applications”, in *IEEE Transactions on Industry Applications*, 2019, vol. 55, no. 6, pp. 7028–7040, doi: 10.1109/TIA.2019.2914418.
- [15] A. Ciocia, A. Amato, P. Di Leo, S. Fichera, G. Malgaroli, F. Spertino, and S. Tzanova, “Self-Consumption and Self-Sufficiency in Photovoltaic Systems: Effect of Grid Limitation and Storage Installation”, *Energies*, vol. 14, no. 6, p. 1591, Mar. 2021, doi: 10.3390/en14061591.
- [16] F. Bizzarri, S. Nitti, G. Malgaroli, “The use of drones in the maintenance of photovoltaic fields,” (2019) *E3S Web of Conferences*, 119, art. no. 00021, doi: 10.1051/e3sconf/201911900021.
- [17] IRENA, “Mobilising institutional capital for renewable energy”, 2020.
- [18] ARERA, “Delibera 04 agosto 2020 318/2020/R/eel”. Available online: <https://www.arera.it/it/docs/20/318-20.htm> (accessed Feb. 28, 2022), Italian language.
- [19] Ministero dello Sviluppo Economico, “Decreto Ministeriale 16 settembre 2020”. Available online: <https://www.mise.gov.it/index.php/it/normativa/decreti-ministeriali/2041756-decreto-ministeriale-16-settembre-2020-individuazione-della-tariffa-incentivante-per-la-remunerazione-degli-impianti-a-fonti-rinnovabili-inseriti-nelle-configurazioni-sperimentali> (accessed Feb. 28, 2022), Italian language.
- [20] UNRAE, “Top 10 per alimentazione - Agosto 2021”. Available online: <http://www.unrae.it/dati-statistici/immatricolazioni/5499/top-10-per-alimentazione-agosto-2021> (accessed Feb. 10, 2022), Italian language.
- [21] UnipolSai Assicurazioni, “Comunicato stampa: presentati i risultati dell’osservatorio UnipolSai sulle abitudini di guida degli italiani in seguito all’analisi dei dati delle scatole nere installate nelle automobili”. Available online: [https://www.unipolsai.com/sites/corporate/files/pages\\_related\\_documents/cs\\_osservatorio-unipolsai-2018.pdf](https://www.unipolsai.com/sites/corporate/files/pages_related_documents/cs_osservatorio-unipolsai-2018.pdf) (accessed Feb. 28, 2022), Italian language.