

Optimum Downlink Beamwidth Estimation in mmWave Communications

Original

Optimum Downlink Beamwidth Estimation in mmWave Communications / Varshney, N., De, S.. - In: IEEE TRANSACTIONS ON COMMUNICATIONS. - ISSN 0090-6778. - STAMPA. - 69:1(2021), pp. 544-557. [10.1109/tcomm.2020.3025356]

Availability:

This version is available at: 11583/2989428 since: 2024-06-14T10:31:54Z

Publisher:

IEEE

Published

DOI:10.1109/tcomm.2020.3025356

Terms of use:

This article is made available under terms and conditions as specified in the corresponding bibliographic description in the repository

Publisher copyright

IEEE postprint/Author's Accepted Manuscript

©2021 IEEE. Personal use of this material is permitted. Permission from IEEE must be obtained for all other uses, in any current or future media, including reprinting/republishing this material for advertising or promotional purposes, creating new collecting works, for resale or lists, or reuse of any copyrighted component of this work in other works.

(Article begins on next page)

Corrosion inhibition of aluminium alloy AA7075-T6 by sodium silicate in chloride solution

F. Rosalbino*, G. Scavino, G. Ubertalli

Politecnico di Torino, Dipartimento di Scienza Applicata e Tecnologia (DISAT), Istituto di Metallurgia; Corso Duca degli Abruzzi, 24 – 10129 Torino, Italy

Abstract

The influence of sodium silicate on the corrosion behaviour of aluminium alloy 7075-T6 in 0.1 M sodium chloride solution was studied by open circuit potential (OCP) and electrochemical impedance spectroscopy (EIS) techniques. Scanning electron microscopy (SEM) was used to characterize the AA7075-T6 surface. Silicate can significantly reduce corrosion deterioration and the inhibition efficiency increases with the concentration of Na_2SiO_3 . The corrosion inhibition mechanism involves the formation of a protective film over the alloy surface by adsorption of aluminosilicate anions from solution, as has also been suggested by others in literature.

Key words: Aluminium alloy 7075-T6; Silicate; Sodium chloride; Electrochemical impedance spectroscopy (EIS); Scanning electron microscopy (SEM)

* Corresponding author. tel: 011 0904760, fax: 0110904699

E-mail address: francesco.rosalbino@polito.it (F.Rosalbino)

1. Introduction

Aluminium and its alloys are attractive materials for a range of industrial applications due to cost-efficient recyclability, excellent physical and mechanical properties, such as low density, high thermal conductivity, good weldability, and high strength-to-weight ratio [1, 2]. However aluminium alloys are prone to localized corrosion if exposed to aggressive environments containing chloride ions [3 - 5]. For a number of decades, protection schemes were based on the chemistry of chromate oxoanions. Chromate and dichromates in aqueous solutions, such as conversion coatings or as pigment primers, impart excellent corrosion protection to most aluminium alloys [6 - 9]. The mechanism of protection is based on the existence of Cr in two oxidation states: Cr(III) oxide provides barrier protection, while the Cr(VI) species are responsible for a “self-repairing” effect [7, 9, 10]. The use of chromate compounds has been restricted in the European Union since September 2017 due to their carcinogenicity and toxicity, mandating more viable alternatives [11]. In this regard, soluble silicates and silicate-based protection schemes have been studied as corrosion inhibitors for aluminium alloys.

Sodium silicate solutions, commercially known as “water glass”, are water-based solutions containing dissolved glass. These aqueous silicates are among the most widely used chemicals for a variety of applications such as cleaners, detergents, binders and coatings. In particular, they are employed in pre-treatments of aluminium alloys as corrosion inhibitors and to confer high hydrophilicity [12]. Silicates provide corrosion protection to various metals by forming a film of adsorbed species on the surface [13, 14].

The effects of silicates and silica deposits have been reported extensively in literature. Adsorption models have been proposed for various metals including iron [15, 16], copper [17], zinc [18, 19], and aluminium [20, 21]. In the case of steel, both Fe^{2+} and Fe^{3+} participate in the formation of a protective layer by reacting with silicate [22].

A few studies have been conducted on the interaction of silicates with aluminium oxides [20, 21, 23]. Firmen et al. proposed a deposition mechanism for monomeric silica coatings on alumina particles in aqueous solution [23]. A random growth mechanism is proposed for the first stage of the layer growth: the silica units approaching the surface stick where they first contact the surface. The silica units have no preference for where they become permanently fixed. Complete coverage of the surface is then achieved at high silica loadings. Gaggiano et al. studied the interaction of soluble sodium silicates on porous anodic alumina [24, 25]. They proposed that aluminosilicate anions in solution react with the aluminate ions formed during oxide dissolution at high pH. The sodium cations act as a coagulating agent between the negatively charged aluminium oxide surface and aluminosilicate anions in solution. Previous studies involving inhibitor combinations have shown a synergistic effect when combining silicate with other inorganic inhibitors [26 – 28]. Taylor and Chambers developed high-throughput methods to assess binary pairing of 12 inorganic chemistries [26]. While some systems exhibited antagonistic behaviour, others demonstrated synergies that were comparable or better than the equivalent concentration of Cr^{6+} . These chemistries included pairings of rare earth cations and vanadates with silicate.

Despite the improved corrosion protection afforded by silicate, little is understood about its effect on aluminium alloys. The purpose of this study is to explore the protection properties of silicate on aluminium alloy (AA) 7075-T6 commonly used in different applications in the aircraft industry. Furthermore, since most inhibiting conversion coatings and pigments act by releasing soluble species into the local aqueous environment, it is of interest to understand the mechanism of inhibition provided by silicate dissolved in aqueous NaCl solution. The work has been performed using open circuit potential (OCP) and electrochemical impedance spectroscopy (EIS) measurements along with scanning electron microscopy investigations.

2. Experimental details

Reagent-grade sodium silicate (Na_2SiO_3) and sodium chloride (NaCl) were used for all experiments.

Solutions were prepared using 18.2 M Ω -cm deionized water.

Samples of solution heat-treated, artificially aged AA7074-T6 (chemical composition in *wt.*%: 90.01% Al, 5.43% Zn, 2.40% Mg, 1.53% Cu, 0.28% Fe, 0.19% Cr, 0.07% Si, 0.04% Mn, 0.03% Ti) were mechanically abraded with SiC paper to 1200 grit in a nonaqueous slurry (Blue Lube from Struers) to minimize the onset of corrosion. All samples were cleaned with ethyl alcohol in an ultrasonic bath, air dried, and stored overnight in a desiccator. For the electrochemical experiments, sample dimensions of $2 \times 2 \times 0.5$ cm were employed.

A three-electrode Pyrex glass cell with a capacity of 250 ml was used in all experiments. The cell was furnished with a large platinum sheet and a saturated calomel electrode (SCE) served as counter and reference electrode, respectively.

The electrochemical experiments were performed with and without silicate additions to naturally aerated 0.1 M NaCl solution ($\text{pH} = 6$). Open circuit potential, E_{OC} , measurements were carried out on freshly polished samples, in naturally aerated aqueous electrolyte without stirring, immediately after polishing. The E_{OC} was continuously monitored during 120 min exposure to the aggressive environment. Electrochemical impedance spectra (EIS) were recorded at E_{corr} using a single sinusoidal excitation signal of 10 mV amplitude while the frequency varied over the range 100 kHz - 10 mHz with at least seven points per decade. All impedance data were fitted to an appropriate equivalent circuit, using both the real and imaginary components of the data. Measurements were performed employing a PAR 2273 electrochemical workstation controlled by a personal computer. For surface examination, Scanning Electron Microscope (SEM) images were recorded using the JEOL JXA-840A electron probe microanalyzer.

3. Results and discussion

Many efforts have been reported in the literature to describe the chemistry of soluble silicates [29 - 33]. It has been shown that the anionic complexation of silicate in solution is related to concentration and the silicon-to-cation ratio (i.e. $\text{SiO}_2/\text{Na}_2\text{O}$). In this study, $\text{SiO}_2/\text{Na}_2\text{O}$ is equal to 1. The solution pH measured after progressive addition of Na_2SiO_3 to 0.1 M NaCl solution is reported in Figure 1.

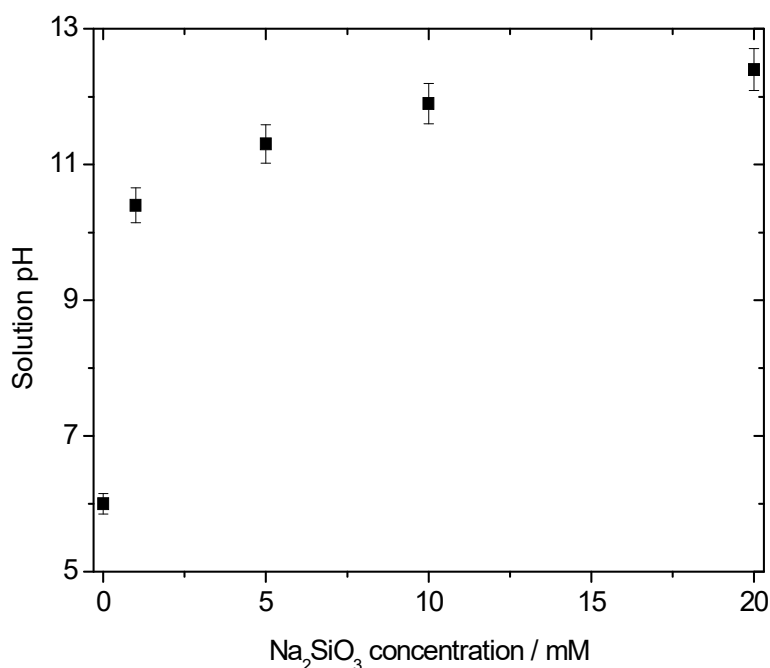

Figure 1 – Effect of silicate concentration on solution pH

As can be seen, increasing the silicate concentration increases the solution pH. The increase in pH can be explained by the formation of silicic acid and hydroxyl ions as described in the following chemical equation [29]:



Gaggiano et al. used solid-state ^{29}NMR to study anionic species in silicate solution at 0.1 M concentration [25]. For $\text{SiO}_2/\text{Na}_2\text{O} = 1$ the main species in solution was found to be silicate monomers, which can be represented as $(\text{HO})_{4-x}\text{SiO}_x^{x-}$ according to Swaddle [30].

Figure 2 shows the time dependence of the open circuit potential, E_{OC} , for AA7075-T6 monitored over a period of 120 min in quiescent 0.1 M NaCl solution. Upon immersion, the E_{OC} of AA7075-T6 in 0.1 M NaCl is -800 mV, but within 700 s reaches -745 mV, and then remains approximately constant. The spontaneously formed passive oxide layer consists of an inner amorphous layer and more permeable outer layer of hydrated oxide, mainly described as AlOOH [4, 34].

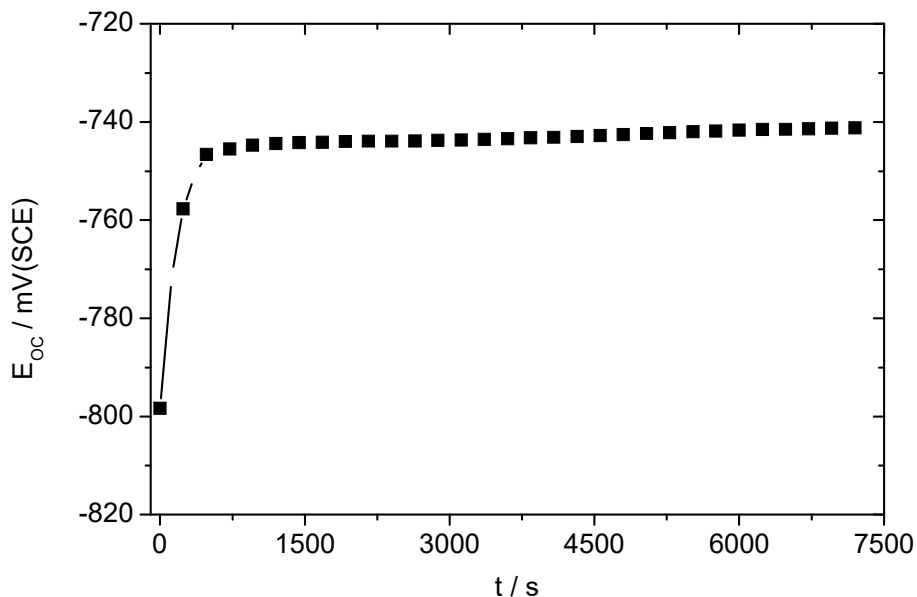

Figure 2 – Open circuit potential, E_{OC} , vs. time profile for AA7075-T6 after 2 h exposure to naturally aerated 0.1 M NaCl solution

Figure 3 shows the evolution over time of the open circuit potential of AA7075-T6 in naturally aerated 0.1 M NaCl with varying Na_2SiO_3 concentration (1.0 – 20.0 mM). The transients have all similar trend, where the potential rapidly increases from the incipient of immersion, and then gradually tends

towards a quasi-steady value less negative than the initial one (at $t = 0$). During immersion, a balance is established between the dissolution of the substrate and formation of the surface layer, resulting in a relatively stable potential.

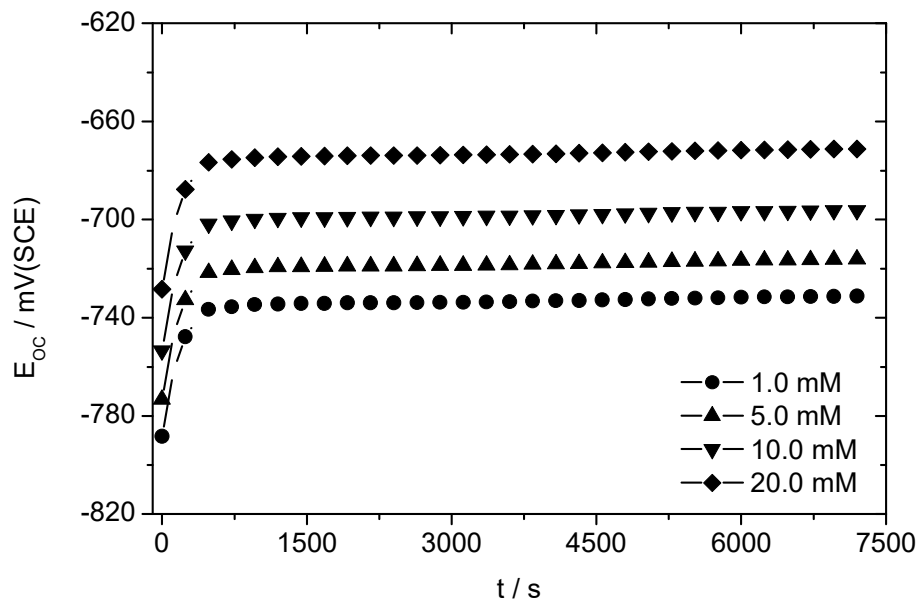

Figure 3 – Open circuit potential, E_{OC} , vs. time profile for AA7075-T6 after 2 h exposure to naturally aerated 0.1 M NaCl solution with varying Na_2SiO_3 concentration

After 2 h exposure to 0.1 M NaCl, the E_{oc} values are as follows: NaCl (-740 mV) < 1.0 mM Na_2SiO_3 (-730 mV) < 5.0 mM Na_2SiO_3 (-715 mV) < 10.0 mM Na_2SiO_3 (-695 mV) < 20.0 mM Na_2SiO_3 (-670 mV), i.e. the addition of Na_2SiO_3 causes a positive shift of E_{oc} compared to NaCl, indicating that silicate can act as an anodic-type inhibitor. The results in general demonstrate that the inhibiting effect of Na_2SiO_3 could be resulted in the dissolution of aluminium-oxide and formation of a silicate-based film over the alloy surface, thereby enhancing passivity.

Corrosion damage results from electrochemical reactions, and electrochemical measurements can often reveal the corrosion mechanism. Electrochemical impedance spectroscopy (EIS) is a technique

with a small perturbing signal, and which causes very little damage to the sample. EIS is essentially a steady-state technique that is capable of accessing relaxation phenomena where relaxation times vary over orders of magnitude, and permits single averaging within a single experiment to obtain high precision levels. Besides, the corrosion mechanism can be estimated by analyzing the measured electrochemical impedance spectrum [35, 36]. The EIS characteristics of AA7075-T6 in quiescent 0.1 NaCl solution containing various Na₂SiO₃ additions in the domain 1.0 – 20.0 mM were recorded at the open circuit potential after immersing the sample in each solution for 120 min to reach a quasi stationary condition. The natural pH measured in the silicate containing solutions was between 10.7 and 12.4. In addition, the experiment was also performed in as prepared (pH = 6) 0.1 M NaCl solution with no silicate. Figure 4 presents the impedance results as Nyquist plots. The general profile of the spectra is similar for all solutions without and with Na₂SiO₃. The presence of the inhibitor only increases the impedance without changing other aspects of the behaviour. The increase in impedance can be ascribed to the formation of a protective film over the aluminium alloy surface that increases the resistance of the alloy. As can be seen, the impedance spectra are characterized by a depressed single capacitive loop during the whole frequency range, whose diameter increases with the increase in silicate concentration. The depressed capacity loop is typical of solid metal electrodes that show frequency dispersion [37]. The use of constant phase element (CPE) in the equivalent circuit of the impedance not only minimizes the systematical error but also provides more detailed information about the non-ideal dielectric properties of the adsorbed inhibitor layer. CPE is required for modeling the frequency dispersion behaviour corresponding to different physical phenomena such as surface heterogeneity which results from surface roughness, impurities, dislocations, distribution of the active sites, adsorption of inhibitors and formation of porous layers [38]. The CPE is defined by the following equation:

$$Z = Y_0^{-1} (j\omega)^{-n} \quad (2)$$

where Y_0 and n are the admittance and empirical exponent of the CPE, respectively, j is an imaginary number and ω is the angle frequency. For $n = 1$, an ideal capacitor is defined. For $n = 0$, the CPE represents an ideal resistor. For $n = -1$, the CPE is equivalent with an inductance. Thus, using a CPE instead of a capacitor provides the deviation from ideal capacitive behaviour [39, 40].

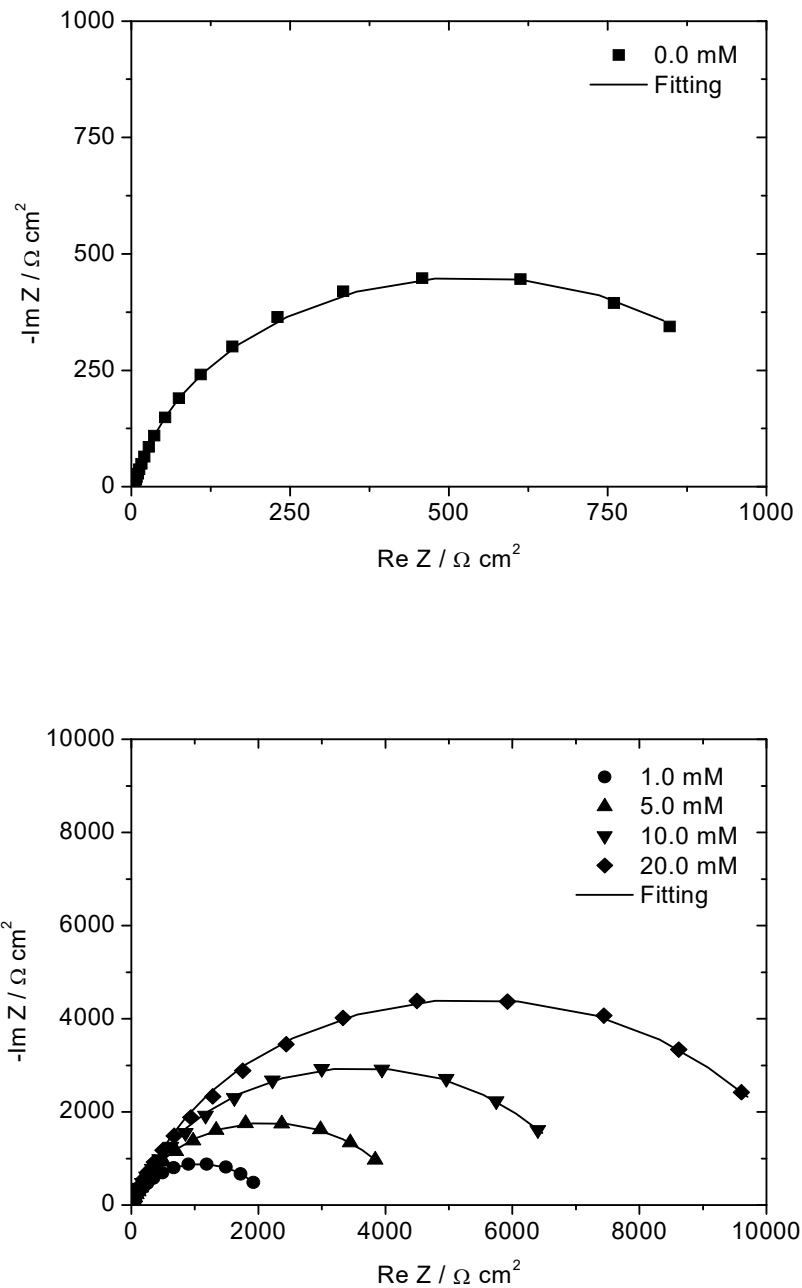

Figure 4 – Electrochemical impedance spectra as Nyquist plots for AA7075-T6 in 0.1 M NaCl solution as a function Na₂SiO₃ concentration, traced after 120 min exposure at 25°C

Generally, the impedance response of an actively corroding metal in an aqueous solution is well simulated by pure electric circuit (EC) of simple Randles model approximated by an ohmic solution resistance, R_s , series connected with a parallel resistor, R_f , and capacitor, C_f , combination, representing the corrosion products film on the sample surface [41]. The impedance data were thus analyzed using Boukamp's software [42] provided with the measuring impedance system and the proposed EC shown in Figure 5. The Nyquist plots deduced from the experimentally and simulated data show that the fitting results are in good agreement with the experimental data. The accuracy of fitting results, shown as solid lines in Figure 4, was evaluated by the chi-squared (χ^2) values, which were in the order of 10^{-4} for all samples.

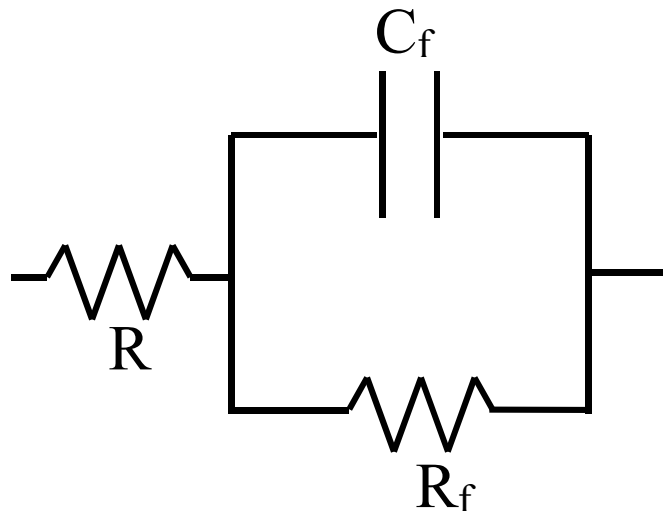

Figure 5 – Simplified Randles circuit used in the fitting procedure of the experimental EIS data

The inhibition efficiency is calculated using the following equation [43, 44]:

$$\% \text{ IE} = [1 - (R_f^0 / R_f)] \times 100 \quad (3)$$

where R_f^0 and R_f represent the surface film resistance for AA7075-T6 in the absence and presence of Na_2SiO_3 . As can be seen in Figure 6, the inhibition efficiency increases with the increase in silicate concentration.

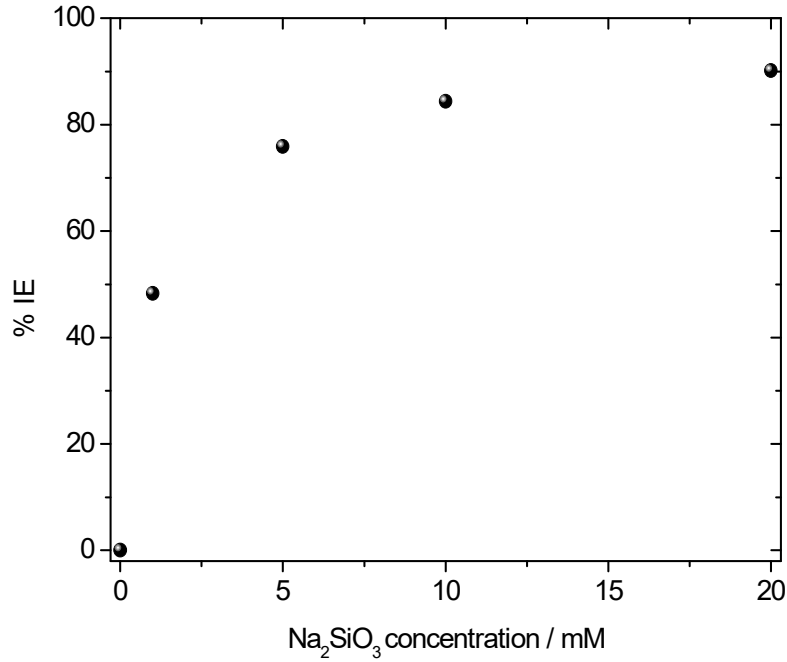

Figure 6 – Inhibition efficiency as a function of silicate concentration for AA7075-T6 in 0.1 M NaCl solution at 25 °C

The surface film capacitance, C_f , for a circuit including CPE were calculated using the following equation [45]:

$$C_f = Y^{1/n} R_t^{(1-n)/n} \quad (4)$$

where Y and n represent the CPE magnitude and exponent, respectively.

Since the passive film on the metal surface can be considered as a dielectric plate capacitor, C_f is inversely proportional to the film thickness, d , in cm following the formula [41, 46, 47]:

$$d = (\epsilon_r \epsilon_0 A) C_f^{-1} \quad (5)$$

where ϵ_0 is the vacuum permittivity (8.85×10^{-12} F cm⁻¹), ϵ_r is the relative dielectric constant of the film, and A is the electrode area in cm². Figure 7 shows the influential role of silicate additions on the surface film stability of AA7075-T6 in 0.1 M NaCl solution. It can be observed that both R_f and $1/C_f$

increase with increasing Na_2SiO_3 concentration. The results clearly demonstrate the reactivity of silicate towards enhancing spontaneous growth of a thicker and more protective surface film on AA7075-T6 via a dissolution-formation mechanism.

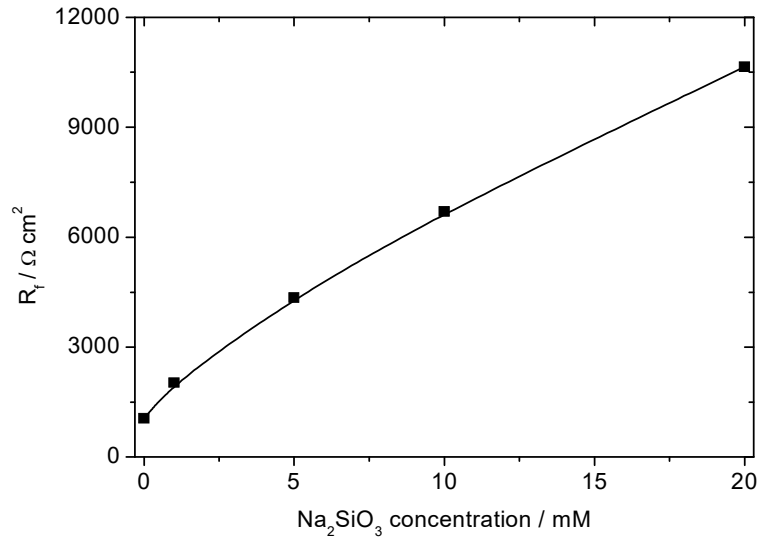

(a)

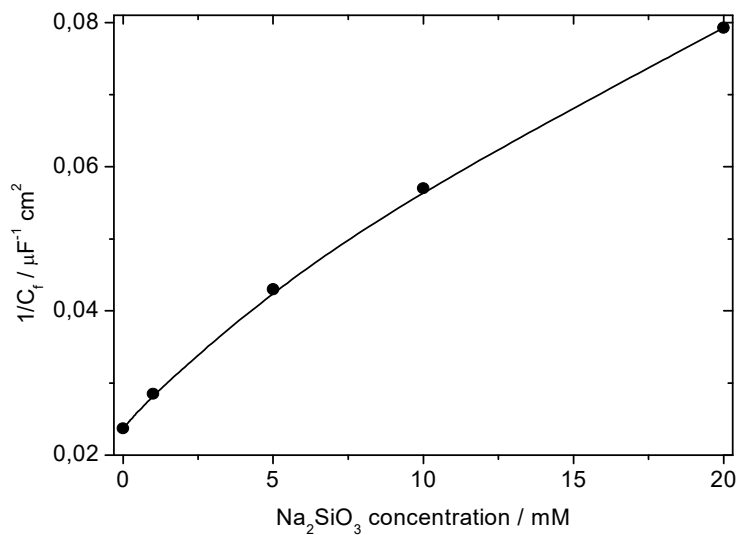

(b)

Figure 7 – Influence of silicate concentration on (a) surface film resistance, R_f , and (b) its relative thickness, $1/C_f$, formed on AA7075-T6 in 0.1 M NaCl solution at 25°C

In alkaline conditions, the aluminum oxide film is chemically unstable and dissolved in solution to form aluminate ions $Al(OH)_4^-$ [30, 48, 49]. The resulting aluminate ions react with the monomeric silicate anions in solution to form aluminosilicate species as described by the following chemical reaction proposed by Swaddle [30]:

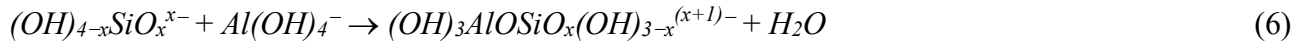

It is known that the isoelectric point of oxide-covered aluminium is 9 - 9.5 [50, 51]. Therefore, in alkaline silicate solution both the oxide surface and the aluminosilicate anions are negatively charged. As suggested by Iler, the deposition of silicate anions at a negatively charged oxide surface requires the presence of a potential coagulating agent, usually a small concentration of polyvalent metal ions [29]. However, other authors have suggested that univalent metal ions can also behave as coagulating agents. For instance, Gaggiano et al. [24, 25] suggested that hydrated Na^+ ions, resulting from the following reaction:



adsorb on the negatively charged oxide surface and behave as a coagulating agent. The Na^+ ions on the surface coordinate with the oxygen atoms of hydroxyl group of the aluminosilicate anions, $(OH)_3AlOSiO_x(OH)_{3-x}^{(x+1)-}$, forming a coordination linkage between the anions and the surface. After the formation of the first chemisorbed aluminosilicate layer, further adsorption occurs by physical interaction with the chemisorbed layer already formed on the alloy surface. The resulting silicate layer grows with time, thereby providing a more compact and protective surface film over the aluminium alloy with increasing the Na_2SiO_3 concentration as supported by the open circuit potential and impedance spectra. The same mechanism has also been proposed by Gaggiano et al. [24, 25].

In order to differentiate between the surface morphology of AA7075-T6 after exposure to 0.1 M sodium chloride solution in the absence and in the presence of Na_2SiO_3 , scanning electron microscopy investigations were carried out. Figure 8a shows the SEM micrograph obtained for the AA7075-T6

surface after 120 min exposure to 0.1 M NaCl solution. In the absence of inhibitor, there are clear signs of corrosion on the sample surface. Figure 8b reports the SEM micrograph obtained for the AA7075-T6 surface after 120 min exposure to 0.1 M NaCl solution containing 20.0 mM Na₂SiO₃. No attack is observed over the sample surface due to the presence of silicate film thus protecting the aluminium alloy from corrosion.

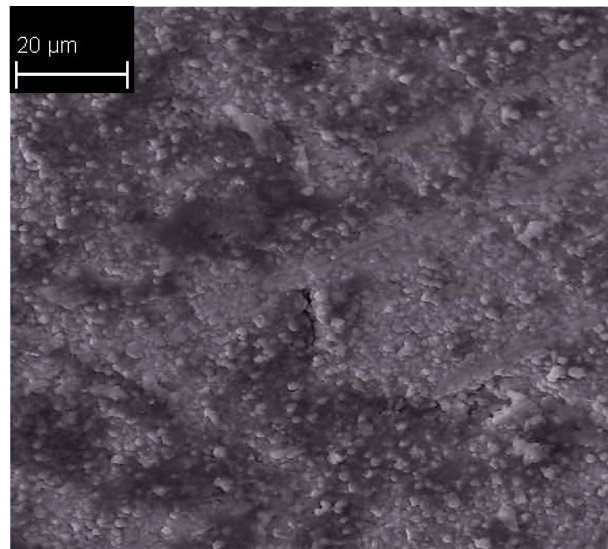

(a)

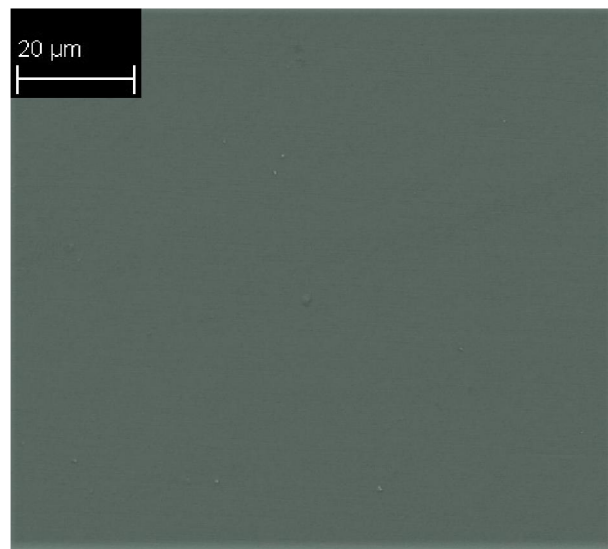

(b)

Figure 8 – SEM micrographs of AA7075-T6 after 120 min exposure at 25°C in (a) 0.1 M NaCl and (b) 0.1 M NaCl + 20.0 mM Na₂SiO₃

4. Conclusions

Addition of silicate can effectively improve the corrosion resistance of AA7075-T6 in 0.1 M NaCl solution.

Increasing Na₂SiO₃ concentration significantly decreases the corrosion rate and shifts positively the corrosion potential, E_{corr} . This is due to formation of a thicker and more compact film over the aluminum alloy surface.

Corrosion inhibition of AA7075-T6 by silicate conforms to the mechanism suggested by Gaggiano et al. [24, 25]. It was proposed that aluminosilicate was formed by the reaction of silicate anions in solution and the aluminate ions that formed by oxide dissolution. The Na⁺ ions adsorbed on the negatively charged surface and coordinated with the oxygen atoms of hydroxyl group of the aluminosilicate anions, thereby forming a protective film over the alloy surface.

SEM investigations revealed high corrosion protection of AA7075-T6 surface in sodium chloride medium containing the highest Na₂SiO₃ concentration.

5. References

- [1] J.R. DAVIS, ASM Specialty Handbook: Aluminium and Aluminium Alloys, 1993, ASM International, Materials Park, USA
- [2] L.F. MONDOLFO, Aluminium Alloys: Structure and Properties, 2013, Elsevier, UK
- [3] N. BIRBILIS, R.G. BUCHEIT, J. Electrochem. Soc. 152 (2005) B140
- [4] G.S. CHEN, M. GAO, R.P. WEI, Corrosion 52 (1996) 8
- [5] N. BIRBILIS, M.K. CAVANAUGH, R.G. BUCHEIT, Corros. Sci. 48 (2006) 4202
- [6] F. ANDREATTA, M.M. LOHRENGEL, H. TERRYN, J.H.W. DE WIT, Electrochim. Acta 48 (2003) 3239
- [7] M.W. KENDIG, S. JEANJAQUET, R. ADDISON, J. WALDROP, Surf. Coat. Technol. 140 (2001) 58

- [8] P.L. HAGANS, C.M. HAAS, Surf. Eng. 274 (1994) 405
- [9] M.W. KENDIG, R.G. BUCHEIT, Corrosion 59 (2003) 379
- [10] P. POKORNY, P. TEJ, P. SZELAG, Metalurgija 55 (2016) 253
- [11] ECHA European Chemical Agency, Chromium VI Compounds – ANNEX XVII TO REACH –
Conditions of restriction
- [12] P.G. SHEASBY, R. PINNER, S. WERNICK, The Surface Treatment and Finishing of
Aluminium and its Alloys, 2001, ASM International
- [13] V.S. SASTRI, E. GHALI, M. ELBOUDJANI, Corrosion Prevention and Protection: Practical
Solutions, 2007, Wiley, Chichester, England
- [14] L. LEHRMAN, H.L. SHULDENER, Ind. Eng. Chem. 44(1952) 1765
- [15] X.F. YANG, P. ROONASI, A. HOLMGREN, J. Colloid Interf. Sci. 328 (2008) 41
- [16] R. JOLSTERA, L. GUNNERIUSSON, W. FORSLING, J. Colloid Interf. Sci. 342 (2010) 493
- [17] L.A. GARCIA-CERDA, O. MENDOZA-GONZALEZ, J.F. PEREZ-ROBLES, J. GONZALEZ-
HERNANDEZ, Materials Letters 56 (2002) 450
- [18] R.P. SOCHA, J. FRANSER, Thin Solid Film 488 (2005) 45
- [19] K. ARAMAKI, Corros. Sci. 44 (2002) 871
- [20] R.C. MCCUNE, R.L. SHITS, S.M. FERGUSON, Corros. Sci. 22 (1982) 1049
- [21] M. INOUE, H. OTSU, H. KOMINAMI, T. INUI, J. Mater. Sci. Lett. 11 (1992) 269
- [22] L. LEHRMAN, H.L. SHULDENER, J. Electrochem. Soc. 104 (1957) 398
- [23] L.E. FIRMENT, H.E. BERGNA, D.G. SWARTZFAGER, P.E. BIERSTEDT, M.L.
VANKAVELAAR, Surf. Interface Anal. 14 (1989) 46
- [24] R. GAGGIANO, P. MORIAMÈ, M. BIESEMANS, I. DE GRAEVE, H. TERRYN, Surf. Coat.
Technol. 205 (2011) 5210
- [25] R. GAGGIANO, P. MORIAMÈ, I. VANDENDAEL, I. DE GRAEVE, H. TERRYN, Surf.
Interface Anal. 42 (2010) 321

- [26] S.R. TAYLOR, B.D. CHAMBERS, *Corrosion* 64 (2008) 255
- [27] A.S. HAMDY, *Surf. Coat. Tech.* 200 (2006) 3786
- [28] J.R. CHEN, H.Y. CHAO, Y.L. LIN, I.J. YANG, J.C. OUNG, F.M. PAN, *Surf. Sci.* 247 (1991) 352
- [29] R.K. ILLER, *The Chemistry of Silica: solubility, polymerization, colloid and surface properties, and biochemistry*, 1979, Wiley, New York
- [30] T.W. SWADDLE, *Coordin. Chem. Rev.* 219 (2001) 665
- [31] S.D. KINRADE, T.W. SWADDLE, *Inorg. Chem.* 27 (1988) 4253
- [32] S.D. KINRADE, T.W. SWADDLE, *Inorg. Chem.* 27 (1988) 4259
- [33] J.L. PROVIS, P. DUXSON, G.C. LUKEY, F. SEPAROVIC, W.M. KRIVEN, J.S.J. VAN DEVENTER, *Ind. Eng. Chem. Res.* 44 (2005) 8899
- [34] P. NATISHAN, W.E. O'GRADY, *J. Electrochem. Soc.* 161 (2014) C421
- [35] G. SONG, A. ATRENS, D. ST. JOHN, X. WU, J. NAIRN, *Corros. Sci.* 39 (1997) 1981
- [36] G. SONG, A. ATRENS, X. WU, B. ZHANG, *Corros. Sci.* 40 (1998) 1769
- [37] K.F. KHALED, K. BABIĆ-SAMARDŽIJA, N. HACKERMAN, *Corros. Sci.* 48 (2006) 3014
- [48] J.R. MACDONALD, *J. Electroanal. Chem. Interfacial Electrochem.* 223 (1987) 25
- [39] E.P.M. VAN WESTING, G.M. FERRARI, J.H.W. DE WIT, *Corros. Sci.* 34 (1993) 1511
- [40] F. MANSFELD, *Corrosion* 37 (1981) 301
- [41] U. RAMMELT, G. REINHARD, *Electrochim. Acta* 35 (1990) 1045
- [42] B.A. BOUKAMP, *Solid State Ionics* 18-19 (1986) 136
- [43] T. POORNIMA, J. NAYAK, A. NITYANANDA SHETTY, *Corros. Sci.* 53 (2011) 3688
- [44] G.A. EL-MAHADY, M.M. HEGAZ, F. EL-TAIB HEAKAL, H.E. MAHMOUD, A.M. FATHY, F.M. SAYED, *Int. J. Electrochem. Sci.* 8 (2013) 2816
- [45] G.J. BRUG, A.L.G. VAN DER EDEN, M. SLUYTERS-REHBACH, J.H. SLUYTERS, *J. Electroanal. Chem.* 176 (1984) 275

- [46] G.T. BURSTEIN, *Corros. Sci.* 47 (2005) 2858
- [47] E. BARSUKOV, J.R. MACDONALD, *Impedance Spectroscopy*, 2005, 2nd Edition, J Wiley & Sons, New York
- [48] S.M. MOON, S.I. PYUN, *Corros. Sci.* 39 (1997) 399
- [49] M. POURBAIX, *Atlas of Electrochemical Equilibria in Aqueous Solutions*, 1974, NACE, Houston, Texas
- [50] P. SOMASUNDARAN, *Encyclopedia of Surface and Colloid Science*, 2006, Taylor & Francis, New York
- [51] E. MCCAFFERTY, J.P. WIGHTMAN, *J. Colloid Interf. Sci.* 194 (1997) 344