

Optimal Positioning of Mobile Manipulators Using Closed Form Inverse Kinematics

Original

Optimal Positioning of Mobile Manipulators Using Closed Form Inverse Kinematics / Colucci, Giovanni; Baglieri, Lorenzo; Botta, Andrea; Cavallone, Paride; Quaglia, Giuseppe. - STAMPA. - 120:(2022), pp. 184-191. (Intervento presentato al convegno 31st International Conference on Robotics in Alpe-Adria-Danube Region 2022 tenutosi a Klagenfurt am Wörthersee (AT) nel June 810, 2022) [10.1007/978-3-031-04870-8_22].

Availability:

This version is available at: 11583/2962327 since: 2022-05-18T10:37:08Z

Publisher:

Springer

Published

DOI:10.1007/978-3-031-04870-8_22

Terms of use:

This article is made available under terms and conditions as specified in the corresponding bibliographic description in the repository

Publisher copyright

Springer postprint/Author's Accepted Manuscript (book chapters)

This is a post-peer-review, pre-copyedit version of a book chapter published in Advances in Service and Industrial Robotics. The final authenticated version is available online at: http://dx.doi.org/10.1007/978-3-031-04870-8_22

(Article begins on next page)

Optimal Positioning of Mobile Manipulators Using Closed Form Inverse Kinematics

Giovanni Colucci^[0000–0002–2996–9013], Lorenzo Baglieri,
Andrea Botta^[0000–0002–7272–7132], Paride Cavallone^[0000–0003–4715–4114], and
Giuseppe Quaglia^[0000–0003–4951–9228]

Politecnico di Torino, 10129 Torino, Italy
{giovanni.colucci, andrea.botta, paride.cavallone,
giuseppe.quaglia}@polito.it
lorenzo.baglieri@studenti.polito.it

Abstract. Mobile manipulators have recently been subject to studies and researches thanks to their augmented mobility and interaction capability. In the precision agriculture field, the development and implementation of such systems can be advantageous in every aspect of the farm activities, e.g. harvesting, pruning, or trimming. This paper presents the implementation of a 7 degree of freedom manipulator upon a mobile rover prototype, designed for precision agriculture, in order to perform grape sampling tasks. While the redundancy of the arm is used to perform off-line collision avoidance with the environment and the mobile base itself, thanks to sampling based path planning methods, a closed form inverse kinematics solution allows to select the posture which maximizes the manipulability index of the manipulator. To do so, base mobility is used to reach the target and properly position the arm. The overall architecture was implemented on the real system and successfully validated through experimental tests.

Keywords: Mobile manipulation · Manipulability · Precision agriculture.

1 Introduction

The idea and development of mobile manipulators, robotic systems that can be decomposed into a robotic arm and a mobile base, was firstly introduced at the end of the 80's for industrial purposes, and, since then, the research world has produced systems with a high level of complexity in several application fields [8]. Such general architecture was studied and implemented for precision agriculture purposes to perform common farm activities, e.g. harvesting [6], pruning [3] and spraying [9]. In all of these applications, the use of a robotic arm is fundamental to undertake tasks with a high level of dexterity, such as the selective spraying routine presented in [9].

In this paper, the authors present the implementation of a commercial assistive robotic arm upon the custom mobile base Agri.Q designed for monitoring

and sampling crops and soil. The design of the base and its related locomotion system was widely discussed in previous articles (see [2, 10]) and preliminary studies about the arm installation were carried out [11]. In this work, the overall system architecture is presented, starting from the arm inverse kinematics (IK) formulation and related motion planning to the combined motion of the base and the arm to outperform sampling tasks. The final section presents some experimental results, where the real prototype is tested.

1.1 System architecture

In fig. 1 the Agri.Q mobile manipulator prototype, mainly composed of a custom mobile base and a commercial seven degree of freedom (dof) robotic arm, is presented. The mobile base consists of two locomotion modules, front and rear one, both provided by two driving units. Each driving unit, in turn, is composed of two wheels connected by a rocker arm. The total number of eight wheels provides a good load distribution and the capability to move and navigate also in uneven terrain.

The upper part of the body is covered by a solar panel, designed to recharge the 24 V lithium-ion battery that feeds the locomotion motors, the robotic arm and all the other on-board electronic components. The panel can be oriented thanks to a pitch mechanism, that also can move the arm, causing the increase of its total workspace.

2 Redundancy solution and manipulability optimization

A representation of the commercial 7dof arm, a Kinova Jaco 2 model, is depicted in fig. 2a. It is composed of seven consecutive revolute joints but with a significant

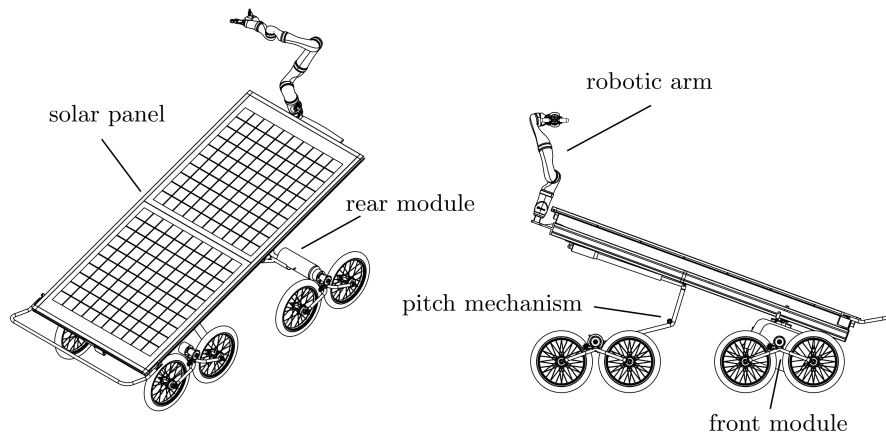

Fig. 1: The mobile manipulator Agri.Q.

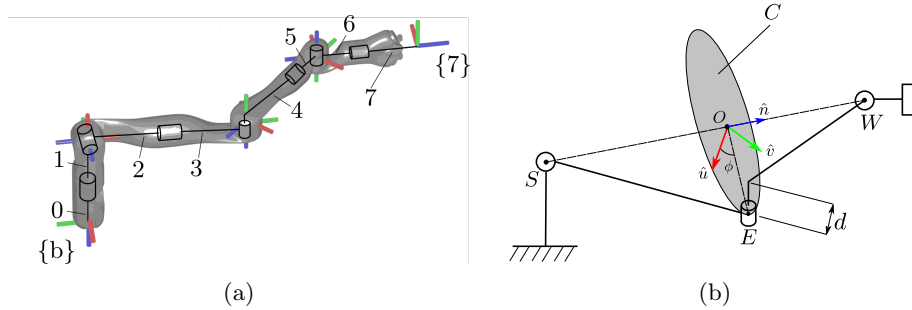

Fig. 2: (a) Kinematic model of the manipulator. (b) Definition of the swivel angle ϕ . For a given constant pose, E must lie on circumference C . Please notice that there is an offset between link 3 and 4.

offset between links 3 and 4 (the distance d in fig. 2b). Since the first three joint axes intersect in a point, they can be treated as a single spherical joint, and the same goes for the last three joints. Moreover, the arm is intrinsically redundant, because its number of degrees of freedom is greater than the dimension of the operational space.

The inverse kinematics problem allows ∞^1 solutions, which can be found through analytical or numerical methods. As an example, the solution can be found using inverse differential kinematics techniques where a cost function $g(\dot{q})$ is minimized [5]. Besides, the authors present a closed form method where all possible solutions are calculated as a function of the Swivel angle ϕ [1, 7]. As shown in fig. 2b, the arm can be modelled as two spherical joints with an intermediate revolute joint which represents, in fact, the redundancy of the system. The circumference C is orthogonal to the shoulder-elbow-wrist (SEW) plane and, moving E around C , all possible IK solutions can be found. The swivel angle, or elbow angle, is defined as the angle between \hat{u} and OE , where \hat{u} can be arbitrarily defined, and Yan et al. proposed a method in order to avoid singularities in its definition [13]. In fig. 3 an illustration of three different postures for the same constant pose is presented.

2.1 Manipulability evaluation

Given that the solution is parametric in terms of ϕ , an optimization method can be introduced to find the best pose with respect to the task. A common approach is the use of the inverse of the 2-norm condition number κ defined as:

$$c = \frac{1}{\kappa(\mathbf{J})} = \frac{\lambda_{min}}{\lambda_{max}} \quad (1)$$

where λ_{min} and λ_{max} are respectively the smallest and largest eigenvalues of Jacobian matrix $\mathbf{J}(\theta)$, and its values are in the range $[0, 1]$. If c is close to 0, the arm is near to a singular configuration, if $c = 1$, the corresponding posture is called *isotropic*.

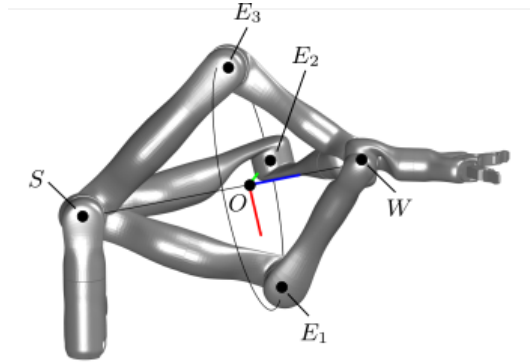

Fig. 3: Use of swivel angle to find three different postures for a given constant pose

To consider also joint limits boundaries, before the computation of c , the Jacobian matrix \mathbf{J} can be modified with some penalization factor p_j , with $j = 1, \dots, 7$, which are a quantitative evaluation of joint limits closeness of a given posture [4, 12]. As firstly introduced in [4] and implemented in [12, 5], a gradient function $\nabla h(\theta)_j$ can be defined as:

$$\nabla(\theta)_j = \frac{\partial h(\theta)}{\partial \theta_j} = \frac{(\theta_{j,max} - \theta_{j,min})^2 (2\theta_j - \theta_{j,max} - \theta_{j,min})^2}{\alpha (\theta_{j,max} - \theta_j)^2 (\theta_j - \theta_{j,min})^2} \quad (2)$$

where $\theta_{j,max}$, $\theta_{j,min}$ are respectively the j -th joint upper and lower limit, and α is a scale factor which relax or emphasize the closeness to joint limits. The penalization factor p_j for the j -th column of \mathbf{J} can now be defined as:

$$p_j = \frac{1}{\sqrt{1 + |\nabla h(\theta)_j|}} \quad (3)$$

For our purpose, a value of $\alpha = 4$ was chosen, as [12] suggests, and, as described by equation (2), p_j goes from 1, when $\theta_j = (\theta_{j,max} - \theta_{j,min})/2$, to ∞ , when θ_j tends to its upper or lower limit.

In fig. 4 the joint angle curves for a given pose are illustrated as a function of the swivel angle ϕ , and a comparison between the original manipulability index c and its new version c_{mod} , modified by the joint limits penalization factors. Please note that, even if some solutions are exact, they are not feasible with the joint limits constraint (dashed line).

Starting from the total set of solutions described by the closed-form inverse kinematics formulation of above, the extracted solution is the one that maximize the value of c_{mod} , i.e. the associated modified manipulability index is maximum.

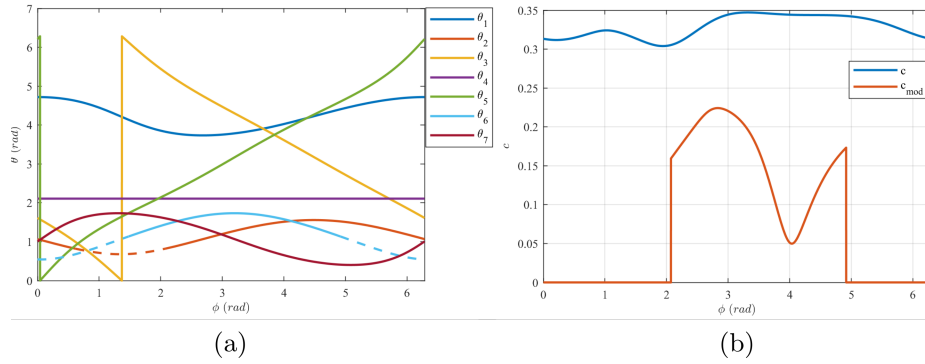

Fig. 4: (a) Joint angles θ_i $i = 1, \dots, 7$ as function of swivel angle ϕ . A dashed line is used to highlight not allowed values due to joint limits. (b) Comparison between c and c_{mod} . c_{mod} is the inverse of the 2-norm condition number of the modified Jacobian matrix for the manipulator.

3 Combined mobility and task execution

To properly interact with its environment, the mobile manipulator Agri.Q can use both the mobile base and manipulator mobility. Since the base mobility is significantly less accurate than the manipulator one, the authors propose a combined motion where the mobile base mobility is used to position the task object inside the manipulator workspace and then only the manipulator performs the task execution. To do so, the base can be modelled as shown in fig. 5, where the position x and the pitch angle ψ are the two degrees of freedom.

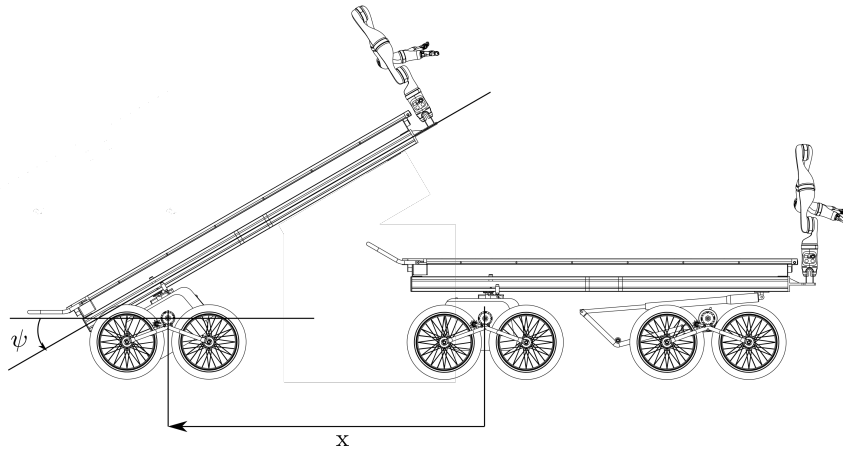

Fig. 5: x linear position and ψ pitch angle for robot arm positioning.

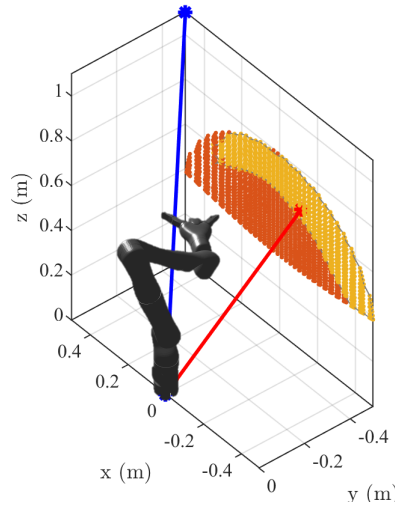

Fig. 6: Manipulability mapping of the workspace of the arm. Blue line: target point, red area: arm workspace, yellow area: best manipulability area, red line: manipulability barycenter of the best manipulability area.

In fig. 6, the developed motion planning of the base is illustrated. For a generic pick-and-place task, if the target object (blue line) is outside the arm workspace (red and yellow area), the developed motion planning procedure moves the mobile base so that the arm can reach the target, also with a good manipulability index. To do so, the target point is moved inside the best manipulability area of the manipulator (yellow area inside the workspace), and specifically into the barycenter of the best manipulability area (red line), where the manipulability index that was used is the above defined c_{mod} . Once the motion is completed, the new target pose is calculated and a motion planning procedure, based on the sampling-based method RRT (rapidly exploring random tree) connect, that is fundamental to guarantee the collision avoidance between the arm and the solar panel of the mobile base, is carried out.

4 Experimental tests

In fig. 7 the experimental setup to validate the system architecture is shown. During this pick-and-place procedure, the arm grasps the target object (the blue cylinder upon the table) and then moves it to its back, where the future placing area of the rover will be placed. All the requested algorithms, e.g., IK solution, motion planning, time scaling, were done on a local pc on Matlab environment. The communication with the mobile base, fundamental to send commands to the pitch and traction actuators, was done through a serial port communication, while the communication with the arm was developed through a Matlab - ROS interface, then sending commands through ROS topics.

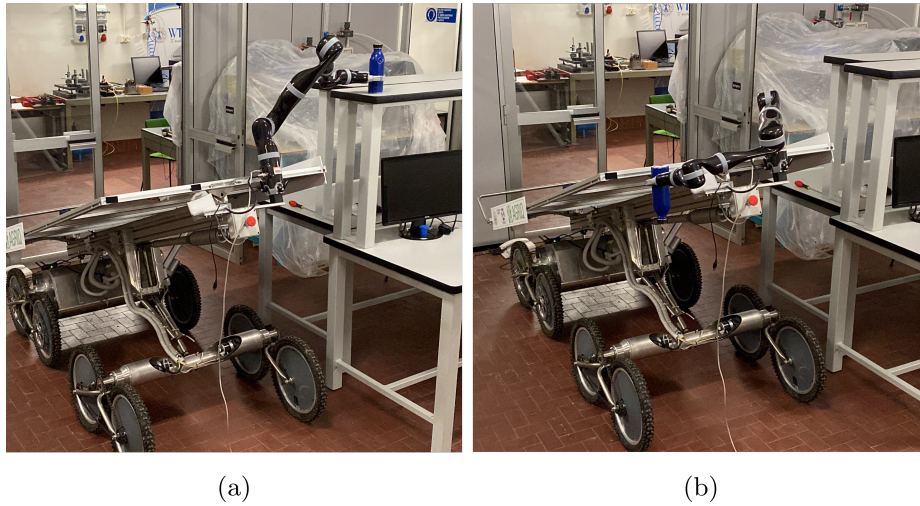

Fig. 7: The prototype during an experimental test. (a) grasp posture (b) place posture

5 Conclusions

In this paper, a planning strategy based on manipulability optimization for the mobile manipulator prototype Agri.Q has been presented. The redundancy of the arm was solved thanks to a closed form formulation, and the solution is parametric in terms of the elbow angle. The mobility of the base is used to properly position the arm so that it can reach the target and manipulate it with the best possible manipulability index. According to that, a planning pipeline, that takes into account both base and arm mobility but separately, was developed in Matlab environment, with the use of RRT connect sampling based method for collision avoidance of the arm with the solar panel of the base. The overall architecture was implemented on the real prototype and validated through experimental tests.

References

1. Artemiadis, P.: Closed-form inverse kinematic solution for anthropomorphic motion in redundant robot arms. In: ICRA 2013 (2013). <https://doi.org/10.4172/2168-9695.1000110>
2. Botta, A., Cavallone, P.: Robotics applied to precision agriculture: The sustainable agri.q rover case study. In: Quaglia, G., Gasparetto, A., Petuya, V., Carbone, G. (eds.) Proceedings of I4SDG Workshop 2021. pp. 41–50. Mechanisms and Machine Science, Springer International Publishing (2022). https://doi.org/10.1007/978-3-030-87383-7_5
3. Botterill, T., Paulin, S., Green, R., Williams, S., Lin, J., Saxton, V., Mills, S., Chen, X., Corbett-Davies, S.: A robot system for pruning grape vines. Jour-

- nal of Field Robotics **34**(6), 1100–1122 (2017). <https://doi.org/10.1002/rob.21680>, <https://onlinelibrary.wiley.com/doi/abs/10.1002/rob.21680>
4. Chan, T.F., Dubey, R.: A weighted least-norm solution based scheme for avoiding joint limits for redundant joint manipulators. *IEEE Transactions on Robotics and Automation* **11**(2), 286–292 (1995). <https://doi.org/10.1109/70.370511>, conference Name: IEEE Transactions on Robotics and Automation
 5. Chen, F., Selvaggio, M., Caldwell, D.G.: Dexterous grasping by manipulability selection for mobile manipulator with visual guidance. *IEEE Transactions on Industrial Informatics* **15**(2), 1202–1210 (2019). <https://doi.org/10.1109/TII.2018.2879426>
 6. De Preter, A., Anthonis, J., De Baerdemaeker, J.: Development of a robot for harvesting strawberries**andreas de preter is supported by a baekeland PhD scholarship (150712) through flanders innovation and entrepreneurship (VLAIO). *IFAC-PapersOnLine* **51**(17), 14–19 (2018). <https://doi.org/10.1016/j.ifacol.2018.08.054>, <https://www.sciencedirect.com/science/article/pii/S2405896318311704>
 7. Faria, C., Ferreira, F., Erlhagen, W., Monteiro, S., Bicho, E.: Position-based kinematics for 7-DoF serial manipulators with global configuration control, joint limit and singularity avoidance. *Mechanism and Machine Theory* **121**, 317–334 (2018). <https://doi.org/10.1016/j.mechmachtheory.2017.10.025>
 8. Hvilshøj, M., Bøgh, S., Skov Nielsen, O., Madsen, O.: Autonomous industrial mobile manipulation (AIMM): past, present and future. *Industrial Robot: An International Journal* **39**(2), 120–135 (2012). <https://doi.org/10.1108/01439911211201582>, <https://doi.org/10.1108/01439911211201582>, publisher: Emerald Group Publishing Limited
 9. Oberti, R., Marchi, M., Tirelli, P., Calcante, A., Iriti, M., Tona, E., Hočevár, M., Baur, J., Pfaff, J., Schütz, C., Ulbrich, H.: Selective spraying of grapevines for disease control using a modular agricultural robot. *Biosystems Engineering* **146**, 203–215 (2016). <https://doi.org/10.1016/j.biosystemseng.2015.12.004>, <https://www.sciencedirect.com/science/article/pii/S1537511015001865>
 10. Quaglia, G., Visconte, C., Carbonari, L., Botta, A., Cavallone, P.: Agri.q: A sustainable rover for precision agriculture. In: Visa, I., Duta, A. (eds.) *Solar Energy Conversion in Communities*. pp. 81–91. Springer Proceedings in Energy, Springer International Publishing (2020). https://doi.org/10.1007/978-3-030-55757-7_6
 11. Quaglia, G., Visconte, C., Scimmi, L.S., Melchiorre, M., Cavallone, P., Pastorelli, S.: Design of a UGV powered by solar energy for precision agriculture. *Robotics* **9**(1), 13 (2020). <https://doi.org/10.3390/robotics9010013>, <https://www.mdpi.com/2218-6581/9/1/13>
 12. Vahrenkamp, N., Asfour, T., Metta, G., Sandini, G., Dillmann, R.: Manipulability analysis. In: 2012 12th IEEE-RAS International Conference on Humanoid Robots (Humanoids 2012). pp. 568–573. IEEE (2012). <https://doi.org/10.1109/HUMANOIDS.2012.6651576>, <http://ieeexplore.ieee.org/document/6651576/>
 13. Yan, L., Mu, Z., Xu, W.: Analytical inverse kinematics of a class of redundant manipulator based on dual arm-angle parameterization. In: 2014 IEEE International Conference on Systems, Man, and Cybernetics (SMC). pp. 3744–3749 (2014). <https://doi.org/10.1109/SMC.2014.6974513>, ISSN: 1062-922X