

Application of artificial dynamics to represent non-isolated single-input multiple-output DC-DC converters with averaged models

*Original*

Application of artificial dynamics to represent non-isolated single-input multiple-output DC-DC converters with averaged models / Qureshi, M. A.; Torelli, F.; Mazza, A.; Chicco, G.. - ELETTRONICO. - (2021), pp. 1-6. ( 56th International Universities Power Engineering Conference, UPEC 2021 Middlesbrough, United Kingdom 31 Aug.-3 Sept. 2021) [10.1109/UPEC50034.2021.9548217].

*Availability:*

This version is available at: 11583/2956461 since: 2022-02-26T12:33:43Z

*Publisher:*

Institute of Electrical and Electronics Engineers Inc.

*Published*

DOI:10.1109/UPEC50034.2021.9548217

*Terms of use:*

This article is made available under terms and conditions as specified in the corresponding bibliographic description in the repository

*Publisher copyright*

IEEE postprint/Author's Accepted Manuscript

©2021 IEEE. Personal use of this material is permitted. Permission from IEEE must be obtained for all other uses, in any current or future media, including reprinting/republishing this material for advertising or promotional purposes, creating new collecting works, for resale or lists, or reuse of any copyrighted component of this work in other works.

(Article begins on next page)

# Torelli Control Box Method Application for Zeta Buckboost and Cuk Boost Combination Converters...

Gianfranco Chicco, Mohammad Ahmed Qureshi, ...

## I. CASE STUDIES

### A. *Dynamic Behavior of a Single Input Multi-output Zeta BuckBoost and Cuk Boost Combination Converters*

In this section, the application of the TCB approach is simulated on a Single Input Multi-output (SIMO) Zeta Buck-Boost (ZBB) and Cuk Boost Combination (CBC) converter topologies as proposed in [1]. With their ability to provide more than one output voltages, the SIMO converters have found various applications in the field of renewable energy, microelectronics, lighting, Hybrid or battery electric vehicles etc [2], [3]. One example of a SIMO converters is the ZBB converter which is a combination of Zeta and Buckboost converter topologies and has been designed in such a way that both of these converters share a switch and an inductor at the input. It is able to provide bipolar output voltage as well as Buck-boost ability using only a single switch. Because of the use of a single switch, it is simpler to design its controller and the reduced components used also means it is inexpensive and has higher efficiency [2]. Similarly, the CBC converter topology is a combination of boost and Cuk converters and provides two different output voltages but with the same polarity. One issue that arises in the modeling of ZBB and CBC converters is that their dynamics are governed by Differential Algebraic Equations (DAE) instead of Ordinary differential equations (ODE) as is the case for conventional converters. This means we cannot use traditional averaging methods to derive its steady state model. In this paper, we have applied

the Torelli Control Box (TCB) approach to simulate the averaged model of both of these converters.

The Zeta Buck-boost converter is shown in Figure 1. The small signal model for this converter has already been derived in [3], [4] using quasi-Weierstrass transformation and the use of consistency projectors. In this example, however, we have modeled both ZBB and CBC converters using the TCB approach instead. Mathematical modeling of the CBC converter has not been done in the literature to the best of our knowledge.

### B. *Steady State Modeling of ZBB Converter*

The ZBB converter shown in Figure 1 has two modes of operations. Let the steady state parameters be defined as follows:

$$\begin{bmatrix} x_1 \\ x_2 \\ x_3 \\ x_4 \\ x_5 \end{bmatrix} = \begin{bmatrix} i_1 \\ i_2 \\ v_{C1} \\ v_{C2} \\ v_C \end{bmatrix}$$

The converter has two modes of operation. In Mode 1 switch S is closed and the diodes are reverse biased. If we denote the total switching period by  $T_s$  and duty ratio D as the ratio for which switch S is ON, then the time interval for mode 1 can be defined as  $0 \leq t \leq DT_s$ . By applying Kirchhoff's voltage and current laws we can write the following equations for mode 1:

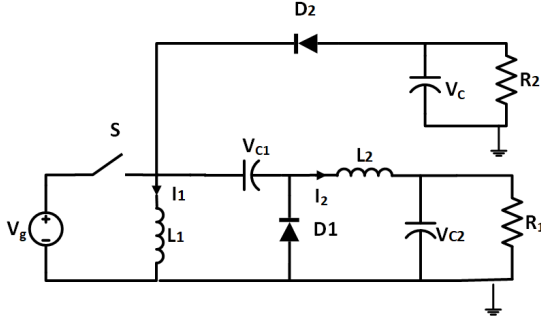

Fig. 1. Zeta BuckBoost Converter

$$\begin{aligned}
 \dot{x}_1 &= \frac{V_g}{L_1} \\
 \dot{x}_2 &= \frac{V_g - x_3 - x_4}{L_2} \\
 \dot{x}_3 &= \frac{x_2}{C_1} \\
 \dot{x}_4 &= \frac{x_2}{C_2} - \frac{x_4}{R_1 C_2} \\
 \dot{x}_5 &= \frac{-x_5}{R_2 C}
 \end{aligned} \tag{1}$$

Similarly in Mode 2, for the interval  $DT_s \leq t \leq T_s$ , switch S is open and diodes  $D_1$  and  $D_2$  are forward biased. Again using Kirchoff's voltage and current laws we can derive the following equations:

$$\begin{aligned}
 \dot{x}_1 &= \frac{x_3}{L_1} \\
 \dot{x}_2 &= \frac{-x_4}{L_2} \\
 \dot{x}_3 &= \frac{-x_1}{C_1 + C} - \frac{x_3}{R_2(C_1 + C)} \\
 \dot{x}_4 &= \frac{x_2}{C_2} - \frac{x_4}{R_1 C_2} \\
 x_5 &= x_3
 \end{aligned} \tag{2}$$

### C. Application of Torelli Control Box Approach

As seen from equation of the converter in mode 2, the dynamics of the converter are constrained by a DAE which does not allow us to use the traditional Volt-second or Charge-second balance to obtain the averaged model of the converter. A possible approach of solving this issue is by

first converting the system equations in mode 2 into simple ODE form. This is done through the process of TCB method described above and system equations have been derived using both sensitivity and without sensitivity parameters.

1) *TCB with Sensitivity Parameters*: Using the procedure described in the previous section, we can define our algebraic constraint as  $g(x) : x_5 - x_3 = 0$ ; and we can define our sensitivity parameters as follows:  $w_1 = \frac{dx_1}{dx_5}$ ;  $w_2 = \frac{dx_2}{dx_5}$ ;  $w_3 = \frac{dx_3}{dx_5}$ ;  $w_4 = \frac{dx_4}{dx_5}$ . Using the TCB approach, we can chose  $x_5$  as our variable  $y$ . Then using equation (eqn 12 of TCB paper mentioned in section above?) mentioned above, we can derive the following equations for mode 2 of our system:

$$\begin{aligned}
 \dot{x}_1 &= \frac{x_3}{L_1} \\
 \dot{x}_2 &= \frac{-x_4}{L_2} \\
 \dot{x}_3 &= \frac{-x_1}{C_1 + C} - \frac{x_3}{R_2(C_1 + C)} \\
 \dot{x}_4 &= \frac{x_2}{C_2} - \frac{x_4}{R_1 C_2} \\
 \dot{x}_5 &= -K(1 - w_3)(x_5 - x_3)
 \end{aligned} \tag{3}$$

The sensitivity parameter equations can be derived as follows:

$$\begin{aligned}
 \dot{w}_1 &= \frac{w_3}{L_1} \\
 \dot{w}_2 &= \frac{-w_4}{L_2} \\
 \dot{w}_3 &= \frac{-w_1}{C_1 + C} - \frac{w_3}{R_2(C_1 + C)} \\
 \dot{w}_4 &= \frac{w_2}{C_2} - \frac{w_4}{R_1 C_2}
 \end{aligned} \tag{4}$$

The sensitivity parameters  $\dot{w}_2$  and  $\dot{w}_4$  are not used in the modeling of our system. As we can see from equation (3) and (4) our converter dynamics in Mode 2 are no longer constrained by DAE. Hence, we can now apply volt-second and charge-second balance to derive the averaged model of our converter as follows:

$$\begin{aligned}
\langle \dot{x}_1 \rangle &= \frac{DV_g}{L_1} + \frac{(1-D)x_3}{L_1} \\
\langle \dot{x}_2 \rangle &= \frac{D(V_g - x_3)}{L_2} - \frac{x_4}{L_2} \\
\langle \dot{x}_3 \rangle &= \frac{x_2 D}{C_1} - \frac{x_1(1-D)}{C_1 + C} - \frac{x_3(1-D)}{(C_1 + C)R_2} \\
\langle \dot{x}_4 \rangle &= \frac{x_2}{C_2} - \frac{x_4}{R_1 C_2} \\
\langle \dot{x}_5 \rangle &= \frac{-x_5 D}{R_2 C} - K(1-D)(1-w_3)(x_5 - x_3)
\end{aligned} \tag{5}$$

2) *TCB without Sensitivity Parameters:* Again following methods described we can derive the averaged equations for the parameters of our converter as follows:

$$\begin{aligned}
\langle \dot{x}_1 \rangle &= \frac{DV_g}{L_1} + \frac{(1-D)x_3}{L_1} \\
\langle \dot{x}_2 \rangle &= \frac{D(V_g - x_3)}{L_2} - \frac{x_4}{L_2} \\
\langle \dot{x}_3 \rangle &= \frac{x_2 D}{C_1} - \frac{x_1(1-D)}{C_1 + C} - \frac{x_3(1-D)}{(C_1 + C)R_2} \\
\langle \dot{x}_4 \rangle &= \frac{x_2}{C_2} - \frac{x_4}{R_1 C_2} \\
\langle \dot{x}_5 \rangle &= \frac{-x_5 D}{R_2 C} - K(1-D)(x_5 - x_3)
\end{aligned} \tag{6}$$

The steady state values of the converter are given by the following equations:

$$\begin{aligned}
x_1 &= \frac{D(1+D)V_g}{(1-D)^2 R}; \quad x_2 = \frac{DV_g}{(1-D)R_1}; \quad x_3 = \frac{-DV_g}{(1-D)}; \\
x_4 &= \frac{DV_g}{1-D}; \quad x_5 = \frac{-DV_g}{(1-D)}
\end{aligned}$$

#### D. Simulation Results

The simulation of the model was done in simulink using an ODE 15s solver with a step time of 0.001s. The specifications for the converter are shown in Table I. The simulation results are given in Figure 5 for the all the parameters except  $V_c$ . To test the validity of the model derived, a step up of duty ratio from  $D = 0.5$  to 0.6 was given at time  $t = 4s$  followed by a step down from  $D = 0.6$  to 0.5 at  $t = 6s$ . The resulting output of the converter model was compared with the theoretical values of the steady state equations derived above.

1) *Response of  $V_c$  due to change in value of  $K$ :* The response of  $V_c$  depends directly on the value

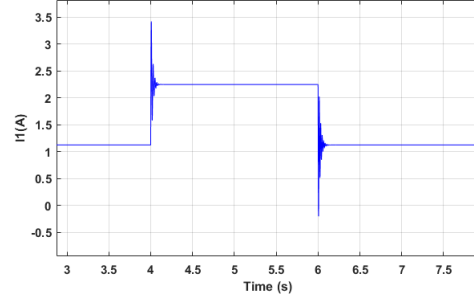

(a)

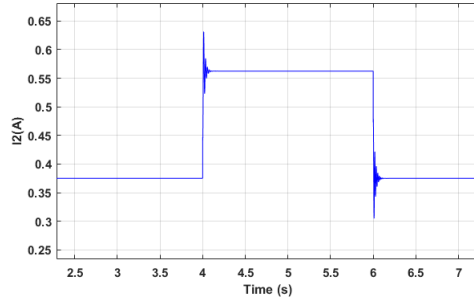

(b)

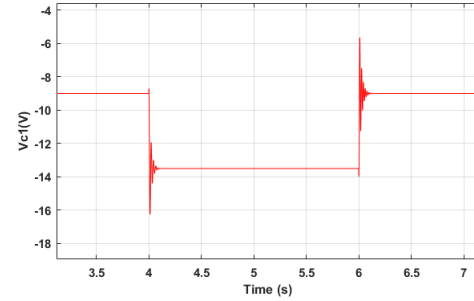

(c)

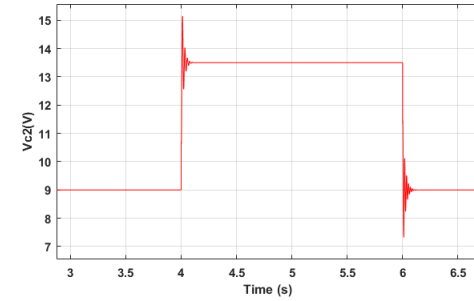

(d)

Fig. 2. Voltage and Current response of ZBB converter parameters (a)  $I_1$  (b)  $I_2$  (c)  $V_1$  (d)  $V_2$  in face of step change in duty ratio from 0.5 to 0.6

TABLE I  
SPECIFICATIONS OF ZETA BUCKBOOST CONVERTER

Description of Parameters	Nominal Value
Capacitor, $C_1$	0.2280 mF
Capacitor, $C_2$	2.5024 uF
Capacitor, $C$	0.2280 mF
Inductor, $L_1$	4.1 mH
Inductor, $L_1$	4.1 mH
Resistance, $R_1$	24 $\Omega$
Resistance, $R_2$	24 $\Omega$
Switching Frequency, $f_s$	50 kHz
Gain, $K$	$10^6$

of gain  $K$ . It is only for the high value of gain  $K = 10^6$  that the value of  $V_c$  tracks its expected value perfectly as shown in Figure 3(b). At lower values of  $K$ , say  $10^4$ , the error between the reference value and the original value increases sufficiently. This is shown in Figure 3(a).

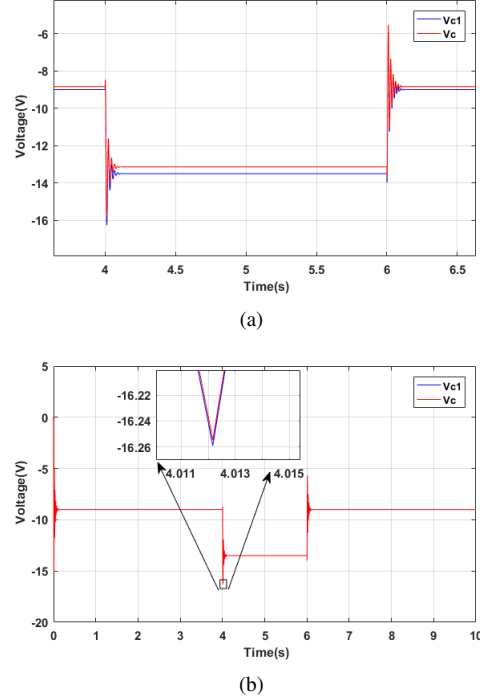

Fig. 3. Response of  $V_c$  (a) With  $K > 10^4$  (b) With  $K > 10^6$

#### E. Steady State modeling of a Single Input Multi-output Cuk Boost Combination Converter

The Cuk Boost Combination converter is shown in Figure 4. Again we can define our steady state parameters as follows:

$$\begin{bmatrix} x_1 \\ x_2 \\ x_3 \\ x_4 \\ x_5 \end{bmatrix} = \begin{bmatrix} i_1 \\ i_2 \\ v_C \\ v_1 \\ v_2 \end{bmatrix}$$

Following the same procedure as in section 1, we can derive the values of steady state parameters in mode 1 and 2. In Mode 1, switch  $S$  is closed and the diodes  $D_1$  and  $D_2$  are reverse biased. By applying Kirchhoff's voltage and current laws we can write the following equations:

$$\begin{aligned} \dot{x}_1 &= \frac{V_g}{L_1} \\ \dot{x}_2 &= \frac{x_4 - x_3}{L_2} \\ \dot{x}_3 &= \frac{x_2}{C} \\ \dot{x}_4 &= \frac{-x_2}{C_1} - \frac{x_4}{R_1 C_1} \\ \dot{x}_5 &= \frac{-x_5}{R_2 C_2} \end{aligned} \quad (7)$$

In Mode 2, switch  $S$  is open and diodes  $D_1$  and  $D_2$  are forward biased. Again using Kirchhoff's voltage and current laws we can derive the following equations:

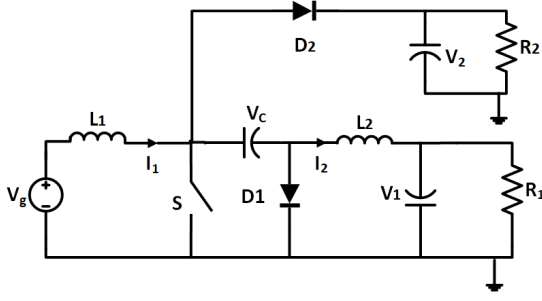

Fig. 4. Cuk Boost Converter

$$\begin{aligned}
 \dot{x}_1 &= \frac{V_g - x_3}{L_1} \\
 \dot{x}_2 &= \frac{x_4}{L_2} \\
 \dot{x}_3 &= \frac{x_1}{C + C_2} - \frac{x_5}{R_2(C + C_2)} \\
 \dot{x}_4 &= \frac{-x_2}{C_1} - \frac{x_4}{R_1 C_1} \\
 x_5 &= x_3
 \end{aligned} \tag{8}$$

#### F. Application of Torelli Control Box Approach

To apply Volt-sec and Charge-sec balance, we need to convert the DAE equation in mode 2 to standard ODE form.

##### 1) TCB with Sensitivity Parameters:

We can define our algebraic constraint as  $g(x) : x_5 - x_3 = 0$ ; and our sensitivity parameters as follows:  $w_1 = \frac{dx_1}{dx_3}$ ;  $w_2 = \frac{dx_2}{dx_3}$ ;  $w_3 = \frac{dx_3}{dx_3}$ ;  $w_4 = \frac{dx_4}{dx_3}$ . Using the TCB approach, we can derive the following equations for mode 2 of our system:

$$\begin{aligned}
 \dot{x}_1 &= \frac{V_g - x_3}{L_1} \\
 \dot{x}_2 &= \frac{x_4}{L_2} \\
 \dot{x}_3 &= \frac{x_1}{C + C_2} - \frac{x_5}{R_2(C + C_2)} \\
 \dot{x}_4 &= \frac{-x_2}{C_1} - \frac{x_4}{R_1 C_1} \\
 \dot{x}_5 &= -K(x_5 - x_3)(1 - w_3)
 \end{aligned} \tag{9}$$

The sensitivity parameter equations can be derived as follows:

$$\begin{aligned}
 \dot{w}_1 &= \frac{-w_3}{L_1} \\
 \dot{w}_2 &= \frac{w_4}{L_2} \\
 \dot{w}_3 &= \frac{w_1}{C_2 + C} - \frac{1}{R_2(C_2 + C)} \\
 \dot{w}_4 &= \frac{w_2}{C_1} - \frac{w_4}{R_2 C_2}
 \end{aligned} \tag{10}$$

In this case as well, the sensitivity parameters  $\dot{w}_2$  and  $\dot{w}_4$  are not being used in the modeling of our system. We can now apply Volt-sec and Charge-sec balance since the dynamics in mode 2 are no longer constrained by a DAE. The averaged model of our converter can be derived as follows:

$$\begin{aligned}
 \langle \dot{x}_1 \rangle &= \frac{V_g}{L_1} - \frac{(1-D)x_3}{L_1} \\
 \langle \dot{x}_2 \rangle &= \frac{x_4}{L_2} - \frac{Dx_3}{L_2} \\
 \langle \dot{x}_3 \rangle &= \frac{x_2 D}{C} - \frac{x_5(1-D)}{(C_2 + C)R_2} + \frac{x_1(1-D)}{(C_2 + C)} \\
 \langle \dot{x}_4 \rangle &= \frac{-x_2}{C_1} - \frac{x_4}{R_1 C_1} \\
 \langle \dot{x}_5 \rangle &= \frac{-x_5 D}{R_2 C_2} - K(1-D)(1-w_3)(x_5 - x_3)
 \end{aligned} \tag{11}$$

2) TCB without Sensitivity Parameters: Again following methods described we can derive the averaged equations for the parameters of our converter as follows:

$$\begin{aligned}
 \langle \dot{x}_1 \rangle &= \frac{V_g}{L_1} - \frac{(1-D)x_3}{L_1} \\
 \langle \dot{x}_2 \rangle &= \frac{x_4}{L_2} - \frac{Dx_3}{L_2} \\
 \langle \dot{x}_3 \rangle &= \frac{x_2 D}{C} - \frac{x_5(1-D)}{(C_2 + C)R_2} + \frac{x_1(1-D)}{(C_2 + C)} \\
 \langle \dot{x}_4 \rangle &= \frac{-x_2}{C_1} - \frac{x_4}{R_1 C_1} \\
 \langle \dot{x}_5 \rangle &= \frac{-x_5 D}{R_2 C_2} - K(1-D)(x_5 - x_3)
 \end{aligned} \tag{12}$$

The steady state values of the parameters can be derived from the volt-sec and charge-sec balance equations as follows:

$$\begin{aligned}
 x_1 &= \frac{V_g}{(1-D)R_2} + \frac{2D^2 V_g}{(1-D)^2 R_1} & x_2 &= \frac{-D V_g}{(1-D)R_1}; \\
 x_3 &= \frac{V_g}{(1-D)}; & x_4 &= \frac{D V_g}{1-D}; & x_5 &= \frac{V_g}{(1-D)}
 \end{aligned}$$

TABLE II  
SPECIFICATIONS OF CUK BOOST COMBINATION CONVERTER

Parameters	Nominal Value
Capacitor, $C$	0.11 mF
Capacitor, $C_1$	2.10 uF
Capacitor, $C_2$	0.11 mF
Inductor, $L_1$	8.1 mH
Inductor, $L_1$	8.1 mH
Resistance, $R_1$	24 $\Omega$
Resistance, $R_2$	24 $\Omega$
Switching Frequency, $f_s$	50 kHz
Gain, $K$	$10^6$

### G. Simulation Results

The simulation was done in simulink using an ODE 15s solver with a step time of 0.001s. The specifications for the converter are shown in Table II. Again to validate the mathematical model derived, a step change of duty ratio  $D$  from 0.5 to 0.6 was given at time  $t = 0.4s$  followed by a step change of  $D$  from 0.6 to 0.5 at  $t = 0.6s$ . The result of simulation of the CBC converter is shown in Figure 5 for the all the parameters except  $V_2$ . The output values of the parameters correspond to the theoretical steady state values of the converter derived above.

1) *Response of  $V_2$  due to change in value of  $K$ :*  
The response of  $x_5$  depends directly on the value of gain  $K$ . It is only for the high value of gain  $K = 10^6$  that the value of  $V_2$  tracks its expected value perfectly as shown in Figure 6(b). At lower values of  $K$ , say  $10^4$ , the error between the reference value and the original value increases sufficiently. This is shown in Figure 6(a).

### H. TCB comparison with literature

The modeling of switched capacitor converters is nontrivial due to the presence of state jumps. The dynamic behavior of converter is then represented by both ODE and algebraic equations in a particular mode of operation. In literature, different methodologies have been proposed to rectify this issue. In [5], [6] switched capacitors have been modeled by

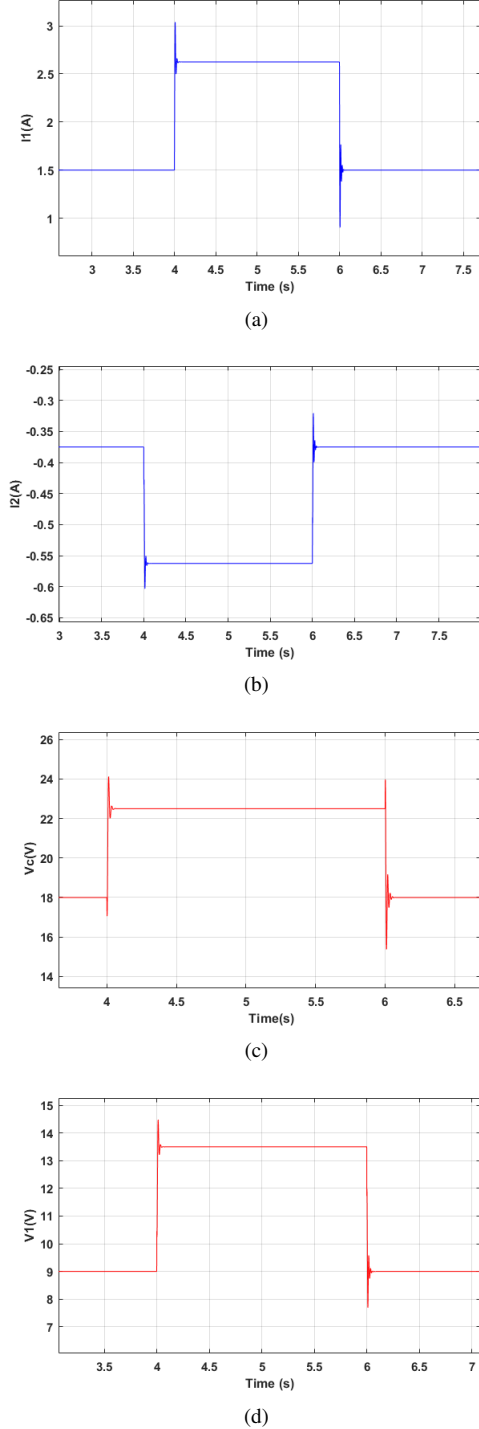
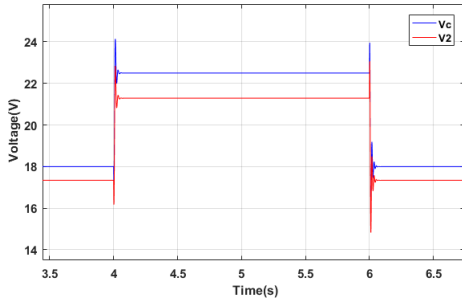
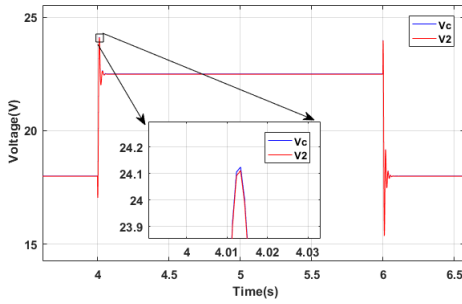

Fig. 5. Voltage and Current response of CBC converter parameters (a)  $I_1$  (b)  $I_2$  (c)  $V_1$  (d)  $V_2$  in face of step change in duty ratio from 0.5 to 0.6



(a)



(b)

Fig. 6. Response of  $V_2$  (a) With  $K > 10^4$  (b) With  $K > 10^6$

considering the losses produced when capacitors are connected in parallel. In [7] an incremental graph approach has been employed for determining steady state voltage gains. In [8], a discrete time framework for the analysis of switched capacitors has been presented. Furthermore, switched dynamic averaged modeling approach has been used for systems with state jumps [4], [9], [10]. This involves the use of quasi-weierstrass transformation and the derivation of consistency projectors to find the equivalent model of the converter.

The use of Torelli control box method, in comparison to the techniques mentioned above, is much more straightforward and allows us to derive the averaged model of the converter using traditional volt and charge second balance methods even in the presence of algebraic equations. The dynamic model derived is asymptotically stable and is insensitive to parametric variations.

## REFERENCES

- [1] M. B. F. Prieto, S. P. Litrán, E. D. Aranda, and J. M. E. Gomez, "New single-input, multiple-output converter topologies: Combining single-switch nonisolated dc-dc converters for single-input, multiple-output applications," *IEEE Industrial Electronics Magazine*, vol. 10, no. 2, pp. 6–20, 2016.
- [2] E. Durán, S. P. Litrán, M. Ferrera, and J. M. Andújar, "A zeta-buck-boost converter combination for single-input multiple-output applications," in *IECON 2016-42nd Annual Conference of the IEEE Industrial Electronics Society*, pp. 1251–1256, IEEE, 2016.
- [3] S. Markkassery, A. D. Mahindrakar, N. Lakshminarasamma, and R. Pasumarthy, "Modelling of non-isolated single-input-multi-output dc-dc converter," in *2018 IEEE International Conference on Power Electronics, Drives and Energy Systems (PEDES)*, pp. 1–6, IEEE, 2018.
- [4] S. Markkassery, A. Saradagi, A. D. Mahindrakar, N. Lakshminarasamma, and R. Pasumarthy, "Modeling, design and control of non-isolated single-input multi-output zeta-buck-boost converter," *IEEE Transactions on Industry Applications*, vol. 56, no. 4, pp. 3904–3918, 2020.
- [5] S. Ben-Yaakov, "Behavioral average modeling and equivalent circuit simulation of switched capacitor converters," *IEEE Transactions on Power Electronics*, vol. 27, no. 2, pp. 632–636, 2011.
- [6] H.-P. Le, S. R. Sanders, and E. Alon, "Design techniques for fully integrated switched-capacitor dc-dc converters," *IEEE Journal of Solid-State Circuits*, vol. 46, no. 9, pp. 2120–2131, 2011.
- [7] M. S. Makowski, "On systematic modeling of switched capacitor dc-dc converters: Incremental graph approach," in *2010 IEEE 12th Workshop on Control and Modeling for Power Electronics (COMPEL)*, pp. 1–6, IEEE, 2010.
- [8] T. Souvignet, B. Allard, and X. Lin-Shi, "Sampled-data modeling of switched-capacitor voltage regulator with frequency-modulation control," *IEEE Transactions on Circuits and Systems I: Regular Papers*, vol. 62, no. 4, pp. 957–966, 2015.
- [9] L. Iannelli, C. Pedicini, S. Trenn, and F. Vasca, "On averaging for switched linear differential algebraic equations," in *2013 European Control Conference (ECC)*, pp. 2163–2168, IEEE, 2013.
- [10] E. Mostacciolo, S. Trenn, and F. Vasca, "Partial averaging for switched daes with two modes," in *2015 European Control Conference (ECC)*, pp. 2896–2901, IEEE, 2015.