

Risk assessment procedure for the performance-based design of landfill lining systems and cutoff walls

*Original*

Risk assessment procedure for the performance-based design of landfill lining systems and cutoff walls / Dominijanni, A., Guarena, N., Manassero, M.. - In: JAPANESE GEOTECHNICAL SOCIETY SPECIAL PUBLICATION. - ISSN 2188-8027. - ELETTRONICO. - 9:(2021), pp. 199-204. (Third International Symposium on Coupled Phenomena in Environmental Geotechnics Kyoto, Japan 20-21 October, 2021) [10.3208/jgssp.v09.cpeg028].

*Availability:*

This version is available at: 11583/2954430 since: 2022-02-01T17:42:08Z

*Publisher:*

The Japanese Geotechnical Society

*Published*

DOI:10.3208/jgssp.v09.cpeg028

*Terms of use:*

This article is made available under terms and conditions as specified in the corresponding bibliographic description in the repository

*Publisher copyright*

(Article begins on next page)

## Risk assessment procedure for the performance-based design of landfill lining systems and cutoff walls

Andrea Dominijanni <sup>i)</sup>, Nicolò Guarena <sup>ii)</sup> and Mario Manassero <sup>iii)</sup>

i) Associate Professor, Department of Structural, Geotechnical and Building Engineering, Politecnico di Torino, Corso Duca degli Abruzzi 42 Torino 10129, Italy.

ii) Ph.D. Student, Department of Structural, Geotechnical and Building Engineering, Politecnico di Torino, Corso Duca degli Abruzzi 42 Torino 10129, Italy.

iii) Professor, Department of Structural, Geotechnical and Building Engineering, Politecnico di Torino, Corso Duca degli Abruzzi 42 Torino 10129, Italy.

### ABSTRACT

The performance-based design of pollutant containment systems, such as landfill bottom liners and cutoff walls, requires the impact of pollutant migration on groundwater quality to be assessed. The effectiveness of pollutant containment systems is indeed demonstrated through the verification that the risk for human health and the environment due to the pollutant migration is limited to an acceptable level. This risk is quantified through the calculation of the pollutant concentration in the groundwater, which is expected to remain less than some prescribed level at a compliance point. The paper describes analytical and numerical solutions to pollutant transport, which allow the pollutant concentration in the groundwater to be calculated under different boundary conditions. Based on the results obtained from these solutions, the role played, not only by the hydraulic and diffusive properties of the containment barriers, but also by the hydrogeological features of the site (e.g. the groundwater velocity and the mechanical dispersion within the aquifer) is pointed out.

**Keywords:** risk assessment, landfill, cutoff wall, contaminant transport

### 1 INTRODUCTION

The design of pollutant barriers, such as waste containment liners and cutoff walls, is aimed at minimizing the impact of pollutant migration on groundwater quality. A common performance criterion for the design is that the barrier must ensure that the concentrations of pollutants in the groundwater remain less than some prescribed threshold level at a specified compliance point, which is typically a monitoring well that is located down-gradient from the landfill or the polluted site. In fact, the pollutant concentration can be related to a corresponding risk for human health and the environment through a toxicological model that takes into account the pollutant features and the exposure paths (Manassero et al., 2000; Katsumi et al., 2001; Foose, 2010).

The pollutant concentration in the groundwater is obtained from a transport analysis, which considers the migration process from the waste or the polluted soil to the compliance point. Dominijanni and Manassero (2019) and Dominijanni et al. (2020) derived analytical and numerical solutions to pollutant transport from landfills under the restrictive assumptions of steady-state conditions and constant source concentration in the waste leachate. These conditions exclude the possibility of modelling time-varying

properties and time-dependent phenomena and typically result in conservative predictions of the groundwater contaminant concentration. As a result, such solutions should not be considered as long-term, realistic simulations of pollutant migration, but rather as conservative estimates of the risk related to a given contaminant concentration in the waste leachate or polluted soil, in a similar way to a tier 2 analysis of the ASTM risk-based corrective action (RBCA) standard.

The main assumptions that were adopted for the derivation of these solutions are:

- 1) the pollutant mass is infinite and the source pollutant concentration,  $c_0$  ( $M/L^3$ ,  $M$  = mass units,  $L$  = length units) is constant in time.
- 2) the analysis is conducted under steady-state conditions.
- 3) the processes of sorption, radioactive decay and biodegradation are conservatively neglected.
- 4) the only attenuation mechanisms that are taken into account are the dilution in the groundwater and the dispersion in the orthogonal direction to the groundwater flow.

In this paper, the solutions are extended to the analysis of pollutant transport through cutoff walls in contaminated sites and to scenarios that involve unconfined flow conditions in thick aquifers.

## 2 THIN AQUIFERS BENEATH A LANDFILL

If the thickness of the aquifer,  $h$ , is no more than a few meters, the vertical component of the groundwater volumetric flux can be neglected with respect to the horizontal one (Haitjema, 1995). The water balance inside an aquifer volume of infinitesimal length,  $dx$ , can be expressed as follows:

$$\frac{dQ_x}{dx} = a_w q \quad (1)$$

where  $Q_x$  ( $L^3/T$ ,  $T$  = time units) is the groundwater discharge in the horizontal direction,  $a_w$  (-) is the portion of barrier area that is wetted by the leachate,  $q$  ( $L/T$ ) is the vertical water volumetric flux and  $x$  ( $L$ ) is the horizontal distance below the landfill taken in the direction of the groundwater flow. After integration of Eq. 1, the discharge  $Q_x$  results to vary linearly beneath the landfill as follows:

$$Q_x = Q_{x0} + a_w q x \quad (2)$$

where  $Q_{x0}$  is the groundwater flux upstream from the landfill, i.e. at location  $x = 0$ .

If the barrier consists of a geomembrane overlying a multi-layer mineral barrier,  $a_w$  represents the fraction of the total area that is wetted by the leachate in correspondence of the geomembrane holes.

Eq. 1 and 2 are valid for both confined and unconfined flow conditions. However, under confined flow conditions, the aquifer thickness,  $h$  ( $L$ ), is constant and the discharge is given by:

$$Q_x = q_x h \quad (3)$$

where  $q_x$  ( $L/T$ ) is the horizontal water volumetric flux. As a result,  $q_x$  can be expressed as follows under confined flow conditions:

$$q_x = q_{x0} + \frac{a_w q}{h} x \quad (4)$$

where  $q_{x0}$  is the water volumetric flux upstream from the landfill, i.e. at location  $x = 0$ .

For thin aquifers, the variation in the vertical direction of pollutant concentration can be assumed to be negligible, and transport by advection is dominant relative to transport by longitudinal hydrodynamic dispersion/diffusion in the horizontal direction (Rowe and Booker, 1985). Under steady-state conditions, the pollutant mass balance inside the aquifer can be obtained by combining the horizontal advective mass flux with the vertical mass flux derived from the landfill,  $J_{ss}$  ( $M/L^2/T$ ) as follows:

$$\frac{d(Q_x c_x)}{dx} = J_{ss} \quad (5)$$

where  $c_x$  ( $M/L^3$ ) is the pollutant concentration in the aquifer beneath the landfill (Fig. 1).

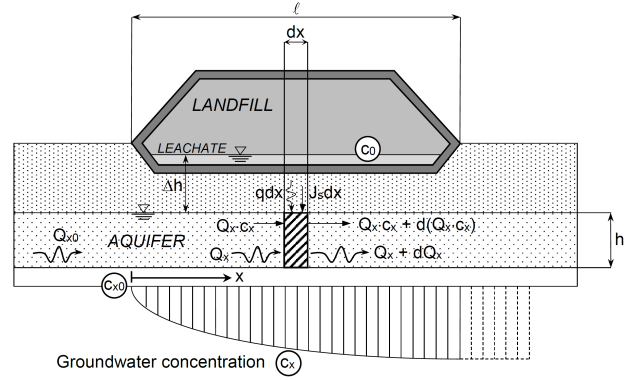

Fig. 1. Reference scheme for the water balance and contaminant mass balance within a thin aquifer beneath the landfill.

The steady state mass flux that is released from the landfill,  $J_{ss}$ , is given by (Dominijanni et al., 2020):

$$J_{ss} = a_w q \frac{c_0 e^{P_L} - c_x}{e^{P_L} - 1} + (1 - a_w) \Lambda_d (c_0 - c_x) \quad (6)$$

where  $P_L$  (-) is the Peclet number of the barrier system,  $c_0$  ( $M/L^3$ ) is the pollutant source concentration,  $c_x$  ( $M/L^3$ ) is the pollutant concentration in the groundwater and  $\Lambda_d$  ( $L/T$ ) is the equivalent diffusivity of the barrier system outside the wetted area.

The vertical volumetric flux,  $q$ , is related to the hydraulic head loss across the multi-layers barrier,  $\Delta h$  ( $L$ ), as follows:

$$q = \frac{1}{\sum_{i=1}^{N_i} \frac{L_i}{k_i}} \frac{\Delta h}{L} \quad (7)$$

where  $L$  ( $L$ ) is total thickness of the barrier,  $L_i$  and  $k_i$  are the thickness and the hydraulic conductivity of the  $i$ -th mineral layer, respectively, and  $N_i$  is the number of the mineral layers that are included in the barrier.

The Peclet number,  $P_L$ , represents the ratio between the advective and the diffusive transport through the barrier and can be expressed as follows:

$$P_L = q \sum_{i=1}^{N_i} \frac{L_i}{n_i D_i^*} \quad (8)$$

where  $n_i$  (-) and  $D_i^*$  ( $L^2/T$ ) are the porosity and the effective diffusion coefficient of the  $i$ -th layer, respectively.

The equivalent diffusivity outside the wetted area,  $\Lambda_d$ , is given by:

$$\Lambda_d = \frac{1}{\frac{L_g}{K_g D_g} + \sum_{i=1}^{N_i} \frac{1}{n_i D_i^*}} \quad (9)$$

where  $L_g$  ( $L$ ) is the thickness of the geomembrane that is placed at the top of the barrier,  $K_g$  (-) is the partition coefficient between the geomembrane and solute,  $D_g$

( $L^2/T$ ) is the diffusion coefficient of the geomembrane.

The mass balance given by Eq. 5 can be solved numerically when  $a_w$ ,  $q$ ,  $P_L$  and  $\Lambda_d$  vary with the distance  $x$ , or analytically when all the parameters are constant (or are given by piecewise-defined constant functions). The analytical solution, associated to the boundary condition

$$c_x(x=0) = c_{x0} \quad (10)$$

where  $c_{x0}$  ( $M/L^3$ ) is the initial groundwater contaminant concentration that comes from upstream of the landfill, is given by:

$$RC = 1 - \left( \frac{\eta}{\eta + X} \right)^\kappa \quad (11)$$

where

$$RC = \frac{c_x - c_{x0}}{c_0 - c_{x0}} \quad (12)$$

$$X = \frac{x}{\ell} \quad (13)$$

$$\eta = \frac{Q_{x0}}{a_w q \ell} \quad (14)$$

$$\kappa = \frac{e^{P_L}}{e^{P_L} - 1} + \frac{(1 - a_w) \Lambda_d}{a_w q} \quad (15)$$

being  $\ell$  (L) the reference distance in the aquifer (e.g. the length of the landfill in the groundwater flow direction).

The following limit conditions can be met:

- 1)  $a_w = 0$ , when the geomembrane is perfectly intact, i.e. without holes. In such case, Eq. 11 reduces to:

$$RC = 1 - \exp\left(-\frac{\Lambda_d \ell}{Q_{x0}} X\right) \quad (16)$$

- 2)  $a_w = 1$ , when the geomembrane is assumed to be completely degraded. In such case, if  $P_L > 4$ ,  $\kappa \rightarrow 1$  and Eq. 11 becomes:

$$RC = 1 - \left( \frac{\eta}{\eta + X} \right). \quad (17)$$

### 3 THICK AQUIFERS UNDER CONFINED FLOW CONDITIONS

When the thickness of the aquifer is not limited to a few meters, the variation in pollutant concentration in the orthogonal direction to the groundwater flow becomes significant, and a two-dimensional geometry needs to be taken into account. Two different scenarios can be considered. The first one is the case of a thick aquifer beneath a landfill, as shown in Fig. 2.

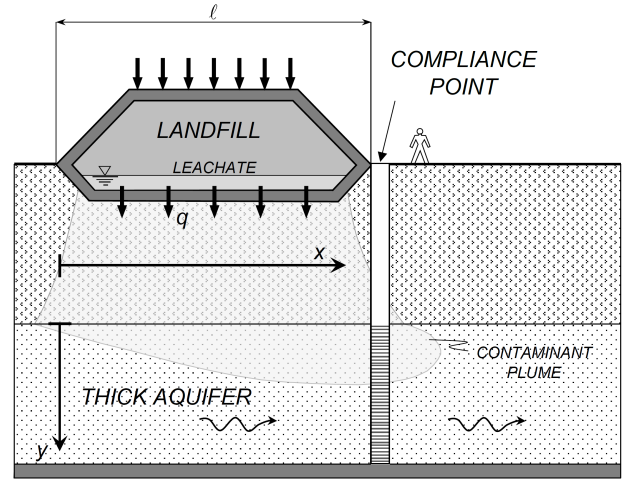

Fig. 2. Reference scheme for the first considered scenario, in which the pollutant released by the waste migrates vertically through the barrier system to the underlying aquifer.

The second one is the case of a contaminated site that is isolated from the surrounding groundwater by a vertical barrier that consists of a cutoff wall, as shown in Fig. 3.

In both the considered scenarios,  $x$  is the direction of the groundwater flow, whereas  $y$  is the orthogonal direction to the groundwater flow.

If the aquifer is sufficiently thick to be considered semi-infinite in the  $y$ -direction and the transversal dispersion is dominant over the other transport mechanisms, the mass balance can be approximated as follows (Dominijanni and Manassero, 2019):

$$\frac{\partial c}{\partial x} = \alpha_T \frac{\partial^2 c}{\partial y^2} \quad (18)$$

where  $\alpha_T$  (L) is the transversal dispersivity.

The associated boundary condition at  $y = 0$  is given by:

$$-\alpha_T q_{x0} \frac{\partial c}{\partial y} = [\xi + (1 - a_w) \Lambda_d] (c_0 - c) \quad (19)$$

where the velocity factor,  $\xi$  (L/T), is given by:

$$\xi = a_w q \frac{e^{P_L}}{e^{P_L} - 1} \quad (20)$$

for the landfill scenario that is represented in Fig. 2, and by:

$$\xi = q_1 \frac{e^{P_{L1}}}{e^{P_{L1}} - 1} + q_2 \frac{e^{P_{L2}}}{e^{P_{L2}} - 1} \quad (21)$$

for the cutoff wall scenario that is shown in Fig. 3.

In the cutoff wall scenario, the volumetric flux is composed by two contributions,  $q_1$  and  $q_2$ , which represent the volumetric flux passing through the wall and the volumetric flux passing through the embedment layer around the wall, respectively.

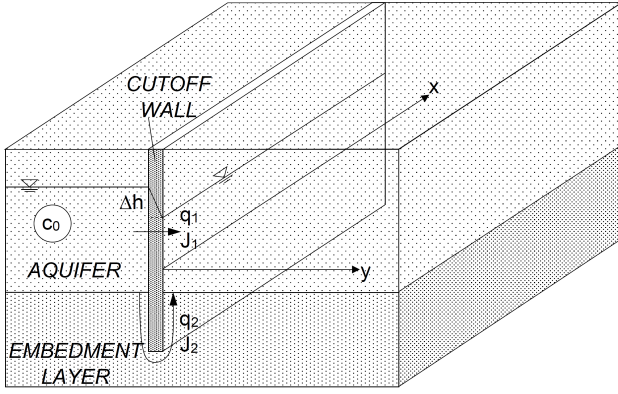

Fig. 3. Reference scheme for the second considered scenario, in which the pollutant migrates from a contaminated site that is laterally contained by a cutoff wall that is embedded in a low-permeability layer.

The volumetric flux,  $q_1$ , is given by:

$$q_1 = k_w \frac{\Delta h}{L_w} \quad (22)$$

where  $k_w$  (L/T) and  $L_w$  (L) are the hydraulic conductivity and the thickness of the cutoff wall, as shown in Fig. 4.

The volumetric flux,  $q_2$ , is given by:

$$q_2 = k_e \frac{\Delta h}{2d_e} \quad (23)$$

where  $k_e$  (L/T) is the hydraulic conductivity of the embedment layer and  $d_e$  (L) is the depth of embedment of the cutoff wall, as shown in Fig. 4.

Similarly,  $P_{L1}$  represent the Peclet numbers that is related to the solute migration through the wall and  $P_{L2}$  is the Peclet number that is related to the solute migration through the embedment layer, respectively.

As a result,  $P_{L1}$  is given by:

$$P_{L1} = \frac{q_1 L_w}{n_w D_w^*} \quad (24)$$

where  $n_w$  (-) and  $D_w^*$  (L<sup>2</sup>/T) are the porosity and the effective diffusion coefficient of the cutoff wall, whereas  $P_{L2}$  is given by:

$$P_{L2} = \frac{q_2 2d_e}{n_e D_e^*} \quad (25)$$

where  $n_e$  (-) and  $D_e^*$  (L<sup>2</sup>/T) are the porosity and the effective diffusion coefficient of the embedment layer.

An analytical solution to Eq. 18, associated with the boundary condition given by Eq. 19 and the initial condition given by Eq. 10, can be derived from the set of solutions provided by Carslaw and Jaeger (1959) and Crank (1975) for heat conduction and mass diffusion problems as follows:

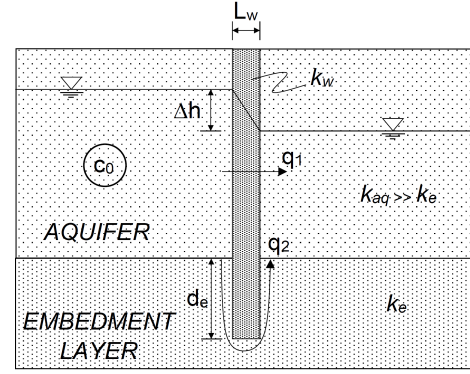

Fig. 4. Vertical section of a cutoff wall embedded in a low-permeability layer.  $L_w$  = cutoff wall thickness,  $\Delta h$  = loss of hydraulic head across the cutoff wall;  $d$  = depth of embedment;  $c_0$  = source pollutant concentration,  $q_1$  volumetric flux through the cutoff wall,  $q_2$  = volumetric flux through the embedment layer,  $k_{aq}$  = hydraulic conductivity of the aquifer,  $k_b$  = hydraulic conductivity of the embedment layer,  $k_w$  = hydraulic conductivity of the cutoff wall.

$$RC = \operatorname{erfc}\left(\frac{Y}{2\sqrt{X}}\right) - \exp(\Gamma Y + \Gamma^2 X) \cdot \operatorname{erfc}\left(\frac{Y}{2\sqrt{X}} + \Gamma\sqrt{X}\right) \quad (26)$$

where

$$Y = \frac{y}{\sqrt{\alpha_T \cdot \ell}} \quad (27)$$

$$\Gamma = \frac{\sqrt{\alpha_T \ell}}{\alpha_T q_{x0}} \left[ \xi + (1 - a_w) \Lambda_d \right] \quad (28)$$

The solution given by Eq. 26 allows the pollutant concentration to be calculated as a function of the space variables,  $x$  and  $y$ , in the semi-infinite aquifer. The same solution can be adapted to both the landfill scenario of Fig. 2 and the cutoff wall scenario of Fig. 3. The attenuation mechanisms that are taken into account are the dilution due to the mixing with the groundwater and the dispersion in the orthogonal direction to groundwater flow.

#### 4 THICK AQUIFERS UNDER UNCONFINED FLOW CONDITIONS BENEATH A LANDFILL

The aquifer beneath the landfill can be characterized by unconfined flow conditions, as shown in Fig. 5. The thickness of the saturated flow,  $h$  (L), varies with the horizontal distance beneath the landfill and the phreatic surface represents a free boundary for the flow problem. The Dupuit-Forchheimer approximation can be adopted for the calculation of  $h$  and the horizontal discharge,  $Q_x$ , without assuming a nil vertical velocity, as pointed out by Haitjema (1995).

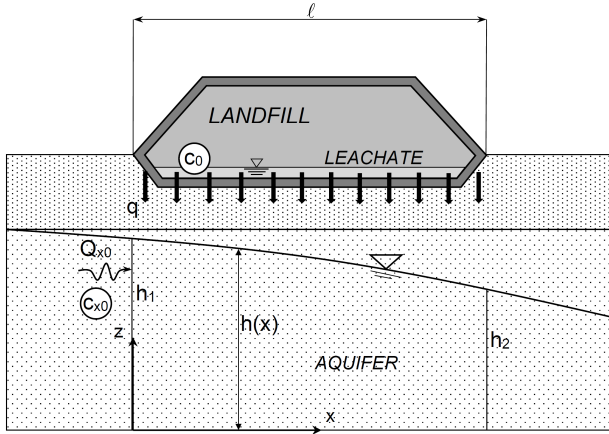

Fig. 5. Reference scheme for a thick aquifer beneath a landfill, under unconfined flow conditions.  $h(x)$  = saturated thickness of the aquifer,  $h_1 = h(x = 0)$ ,  $h_2 = h(x = \ell)$ ,  $q$  = vertical volumetric flux,  $c_0$  source pollutant concentration,  $Q_{x0}$  = horizontal discharge upstream from the landfill,  $c_{x0}$  pollutant concentration upstream from the landfill.

The saturated thickness,  $h$ , can be determined as a function of the values  $h_1$  and  $h_2$  measured at  $x = 0$  and  $x = \ell$ , respectively:

$$h^2 = h_1^2 - \frac{h_1^2 - h_2^2}{\ell} x + \frac{a_w q}{k_{aq}} (\ell - x)x \quad (29)$$

where  $k_{aq}$  (L/T) is the hydraulic conductivity of the aquifer.

The horizontal discharge can be expressed as follows:

$$Q_x = q_x h = \frac{k_{aq}}{2\ell} (h_1^2 - h_2^2) - \frac{a_w q \ell}{2} + a_w q x \quad (30)$$

where  $q_x$  (L/T) is the horizontal velocity of the groundwater.

The vertical groundwater velocity,  $q_z$  (L/T), taken positive in the upward direction, such as the  $z$  axis in Fig. 5, can be derived from the continuity equation of flow:

$$\frac{\partial q_x}{\partial x} + \frac{\partial q_z}{\partial z} = 0. \quad (31)$$

After integration of Eq. 31,  $q_z$  is found to be given by:

$$q_z = \frac{z}{h} \left( \frac{Q_x}{h} \frac{dh}{dx} - q \right). \quad (32)$$

where the following boundary conditions have been assumed:  $q_z(z = 0) = 0$  and  $q_z(z = h) = -q$ .

Using Eq. 29 and 30,  $q_z$  can be calculated as a function of the space variables  $x$  and  $z$  in any point of the aquifer. The first term between the round brackets is due to the curving phreatic surface and was also found by Polubarinova-Kochina (1962) and Haitjema (1995).

When  $h = \text{constant}$  and  $dh/dx = 0$ ,  $q_z$  assumes the same expression that was provided by Dominijanni and Manassero (2019) for confined flow conditions.

The pollutant mass balance can be expressed as follows under steady-state conditions:

$$n_{aq} \frac{\partial}{\partial x} \left( D_{h,x} \frac{\partial c}{\partial x} \right) + n_{aq} \frac{\partial}{\partial z} \left( D_{h,z} \frac{\partial c}{\partial z} \right) - \frac{\partial}{\partial x} (q_x c) - \frac{\partial}{\partial z} (q_z c) = 0 \quad (33)$$

where  $n_{aq}$  is the aquifer porosity,  $D_{h,x}$  and  $D_{h,z}$  are the horizontal and vertical hydrodynamic dispersion/diffusion coefficients in the aquifer, respectively.

If the horizontal volumetric flux in the aquifer is appreciably greater than the vertical volumetric flux, then the transverse mechanical dispersion can be assumed to be dominant relative to molecular diffusion and the longitudinal mechanical dispersion. As a result, the pollutant mass balance can be simplified as follows:

$$\frac{\partial}{\partial x} (q_x c) = \alpha_T q_{x0} \frac{\partial^2 c}{\partial z^2} - \frac{\partial}{\partial z} (q_z c). \quad (34)$$

Taking into account the continuity equation of flow, given by Eq. 31, the pollutant mass balance becomes:

$$q_x \frac{\partial c}{\partial x} = \alpha_T q_{x0} \frac{\partial^2 c}{\partial z^2} - q_z \frac{\partial c}{\partial z}. \quad (35)$$

The main difficulty in solving Eq. 35 is related to the presence of a free-boundary at  $z = h$ , where the following boundary condition must be imposed:

$$q_z c - \alpha_T q_{x0} \frac{\partial c}{\partial z} = -a_w q \frac{c_0 e^{p_L} - c}{e^{p_L} - 1} - (1 - a_w) \Lambda_d (c_0 - c_x) \quad (36)$$

In order to solve such a problem, a possible strategy is to employ a coordinate transformation to map the domain onto a fixed region (Crank, 1987).

Passing from the coordinates  $(x, z)$  to the coordinates  $(\chi, \zeta)$  that are defined as follows:

$$\chi = x \quad (37a)$$

$$\zeta = \frac{z}{h}, \quad (37b)$$

the pollutant mass balance equation must be modified using the following rules of derivation:

$$\frac{\partial}{\partial \zeta} = h \frac{\partial}{\partial z} \quad (37a)$$

$$\frac{\partial}{\partial \chi} = \frac{\partial}{\partial x} + \zeta \frac{dh}{dx} \frac{\partial}{\partial z}. \quad (37b)$$

The pollutant mass balance becomes:

$$q_x \left( \frac{\partial c}{\partial \chi} - \frac{\zeta}{h} \frac{dh}{dx} \frac{\partial c}{\partial \zeta} \right) = \alpha_T q_{x0} \frac{\partial^2 c}{\partial \zeta^2} - q_z \frac{\partial c}{\partial \zeta}. \quad (38)$$

This last equation can be solved in a rectangular domain  $(0,0) \times (\ell,1)$  with the following boundary conditions:

$$q_z c - \alpha_T q_{x0} \frac{\partial c}{\partial \zeta} = -a_w q \frac{c_0 e^{P_L} - c}{e^{P_L} - 1} - (1 - a_w) \Lambda_d (c_0 - c_x) \quad \text{at } \zeta = 1 \quad (39)$$

$$\frac{\partial c}{\partial \zeta} = 0 \quad \text{at } \zeta = 0. \quad (40)$$

$$c = c_{x0} \quad \text{at } \chi = 0. \quad (41)$$

The condition given by Eq. 40 assumes that the pollutant flux is nil at the bottom of the aquifer. A solution of Eq. (38), associated with the boundary conditions given by Eqs 39-41, can be obtained by a numerical method, such as that developed by Dominijanni and Manassero (2019).

## 5 CONCLUSIONS

The paper presents analytical and numerical solutions to assess the contaminant concentration in an aquifer that is located beneath a landfill or around a cutoff wall, taking into account both advective and diffusive transport through the containment system.

These solutions are derived under the restrictive assumptions of steady-state conditions and constant source concentration in the waste leachate or the contaminated groundwater. However, unlike the currently available steady-state solutions that can be found in the literature (Guyonnet et al., 2001; Foose, 2010), the proposed solutions allow the progressive increment of the contaminant concentration that occurs along the direction of the groundwater flow to be appreciated. Moreover, we have presented analytical solutions, which also allow the effect of transversal dispersion to be taken into account in semi-infinite aquifers. For the free-boundary problem of an unconfined groundwater flow that takes place in an aquifer beneath a landfill, a specific solution has been developed by performing a coordinate transformation to map the domain onto a fixed region.

The principal benefit of using such solutions is the possibility of conducting an analysis that involves a limited number of parameters and allows the influence of the barrier properties (e.g. hydraulic conductivity, thickness, defects) and the field conditions (e.g. aquifer thickness, groundwater velocity) on the final result to be evaluated. Since the assumed boundary conditions are conservative with respect to the evaluation of the contaminant concentration within the aquifer, the proposed analysis can be compared to a Tier-2 risk

assessment of the ASTM risk-based corrective action (RBCA) standard for a polluted site.

A possible interesting development of the proposed steady-state analysis is its application in the frame of a probabilistic approach, in which the boundary conditions and the model parameters have a random nature. In fact, a significant difficulty in the analysis arises from the uncertainty that is encountered in the evaluation of the representative values that need to be assigned to various parameters, such as the source contaminant concentration, the hydraulic conductivity of the landfill liners or the cutoff wall, and the number, size and location of the geomembrane defects. In a deterministic approach, the designer must trust in his own good judgement to make the most opportune choice of the parameter values, but cannot know the combined effect of the variance of the various parameters on the final result of the analysis. The adoption of a probabilistic approach instead allows the random nature of the involved parameter to be considered explicitly. In such a way, the final results may be related not only to the most representative values of the involved parameters, but also to their variance.

## REFERENCES

- 1) Carslaw, H.S. and Jaeger, J.C. (1959): *Conduction of heat in solids*, Clarendon Press, Oxford.
- 2) Crank, J. (1975): *The mathematics of diffusion, Second Edition*, Clarendon Press, Oxford.
- 3) Crank, J. (1987): *Free and Moving Boundary Problems*, Clarendon Press, Oxford.
- 4) Dominijanni, A. and Manassero, M. (2019): Steady-state analysis of pollutant transport to assess landfill liner performance, *Environmental Geotechnics*, online ahead of print, <https://doi.org/10.1680/jenge.19.00051>.
- 5) Dominijanni, A., Guarena, N. and Manassero, M. (2020): La progettazione prestazionale dei sistemi di contenimento degli inquinanti nelle discariche (Performance-based design of landfill liners), *Proceedings of the XXVII Italian Congress on Geotechnical Engineering*, AGI, Roma.
- 6) Foose, G.J. (2010): A steady-state approach for evaluating the impact of solute transport through composite liners on groundwater quality, *Waste Management*, 30(8-9), 1577-1586.
- 7) Guyonnet, D., Perrochet, P., Côme, B., Seguin, J.J. and Parriaux, A. (2001): On the hydro-dispersive equivalence between multi-layered mineral barriers. *Journal of Contaminant Hydrology*, 51(3-4), 215-231.
- 7) Haitjema H.M. (1995): *Analytic element modeling of ground-water flow*, Academic Press, San Diego.
- 8) Katsumi, T., Benson, C.H., Foose, G.J. and Kamon, M. (2001): Performance-based design of landfill liners. *Engineering Geology*, 60(1-4), 139-148.
- 9) Manassero, M., Benson, C.H. and Bouazza, A. (2000): Solid waste containment systems, *Proceedings of GeoEng2000*, vol. 1, 520-642, Technomic, Lancaster, PA.
- 10) Polubarinova-Kochina, P.Y. (1962): *Theory of ground water movement*. Princeton University Press, Princeton.
- 11) Rowe, R.K. and Booker, J.R. (1985): 1-D pollutant migration in soils of finite depth, *Journal of Geotechnical Engineering*, 111(4), 479-499.