

Fault-Tolerant Torque Control Based on Common and Differential Mode Modeling for Multi-Three-Phase Induction Machines

Original

Fault-Tolerant Torque Control Based on Common and Differential Mode Modeling for Multi-Three-Phase Induction Machines / Rubino, S.; Armando, E.; Bojoi, R.; Zarri, L. - ELETTRONICO. - (2021), pp. 1-8. (2021 IEEE International Electric Machines and Drives Conference, IEMDC 2021 USA 2021) [10.1109/IEMDC47953.2021.9449509].

Availability:

This version is available at: 11583/2950864 since: 2022-01-18T10:23:29Z

Publisher:

Institute of Electrical and Electronics Engineers Inc.

Published

DOI:10.1109/IEMDC47953.2021.9449509

Terms of use:

This article is made available under terms and conditions as specified in the corresponding bibliographic description in the repository

Publisher copyright

IEEE postprint/Author's Accepted Manuscript

©2021 IEEE. Personal use of this material is permitted. Permission from IEEE must be obtained for all other uses, in any current or future media, including reprinting/republishing this material for advertising or promotional purposes, creating new collecting works, for resale or lists, or reuse of any copyrighted component of this work in other works.

(Article begins on next page)

Fault-Tolerant Torque Control Based on Common and Differential Mode Modeling for Multi-Three-Phase Induction Machines

Sandro Rubino
Dipartimento Energia
“G. Ferraris”
Politecnico di Torino
Torino, Italy
sandro.rubino@polito.it

Eric Armando
Dipartimento Energia
“G. Ferraris”
Politecnico di Torino
Torino, Italy
eric.armando@polito.it

Radu Bojoi
Dipartimento Energia
“G. Ferraris”
Politecnico di Torino
Torino, Italy
radu.bojoi@polito.it

Luca Zarri
Dept. of Electrical,
Electronic and Information
Engineering “G. Marconi”
University of Bologna
Bologna, Italy
luca.zarri2@unibo.it

Abstract—Among the multiphase solutions, multi-three-phase drives are experiencing significant industrial development since they can be configured as multiple three-phase units operating in parallel. The literature reports several control approaches to perform the torque regulation of multi-three-phase machines. Most of such solutions use the vector space decomposition (VSD) approach since it allows the control of a multi-three-phase machine using the conventional control schemes of three-phase drives, reducing the complexity of the control algorithm. However, this advantage is practically lost in the case of open-three-phase faults. Indeed, the post-fault operation of the VSD-based drive schemes requires the implementation of additional control modules, often specifically designed for the machine under consideration. Therefore, this paper aims at proposing a novel control approach that allows using any control scheme developed for three-phase motors to perform the torque regulation of a multi-three-phase machine both in healthy and faulty operation. In this way, the previously mentioned drawbacks of the VSD-based control schemes in dealing with the machine's faulty operation are avoided. Moreover, the simplicity of the control algorithm is always preserved regardless of the machine operating condition. The proposed solution has been experimentally validated through a 12-phase induction motor, rated 10 kW at 6000 r/min, which uses a quadruple-three-phase configuration of the stator winding.

Keywords—direct flux vector control, fault-tolerant torque control, induction motor drives, multiphase electrical machines.

I. INTRODUCTION

Following the current electrification processes involving energy production and transports, multiphase solutions are becoming a competitive alternative to the conventional three-phase motor drives [1], [2]. Indeed, multiphase machines allow a significant reduction of the current levels for a given electric power, making it possible using today's fast power electronics devices. Hence, getting significant advantages in terms of efficiency and power density [3], [4].

Among the multiphase solutions, multi-three-phase motor drives are experiencing significant interest from the industry. Indeed, such systems allow configuring a multiphase machine as multiple three-phase units operating in parallel [1]. In this way, several advantages can be obtained. The first advantage is a straightforward machine design since the stator consists of multiple three-phase winding sets having isolated neutral points. The second advantage consists of using three-phase inverter power modules, reducing cost and design time. Indeed, three-phase inverter modules are used to feed each winding set, as shown in Fig. 1. Therefore, the fault-tolerance capability is implemented in agreement with the three-phase modularity [1].

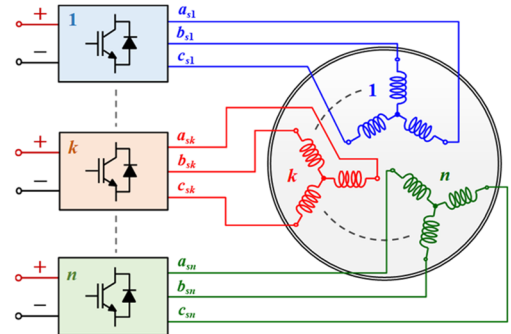

Fig. 1. Multi-three-phase drive topology.

In the case of a fault reported by one power module, this is turned off, and therefore the corresponding unit, i.e., winding set plus inverter, is disconnected from the dc-link [5]. Hence, getting a straightforward post-fault drive reconfiguration. Finally, the third advantage consists of implementing power-sharing strategies among the three-phase winding sets [5], [6]. Such strategies help the series-parallel systems [6], [7], i.e., series or parallel connection of the dc-links belonging to the three-phase inverter units. Application examples of such systems can be found in wind energy production [6]. However, it is highlighted that most of the multi-three-phase drives for high-power applications (e.g., oil and gas [8]) usually operate with balanced operation among the units, optimizing the overall machine efficiency [6].

Regardless of the drive operation, most of the control solutions implemented for multi-three-phase machines are undoubtedly based on the vector space decomposition (VSD) approach [9]. The VSD approach decomposes the multiphase machine model as multiple time-harmonic subspaces. If a sinusoidal distribution of the stator windings is considered, one main subspace performs the electromechanical energy conversion. Conversely, the other subspaces have the meaning of time-harmonic and zero-sequence patterns of the machine [10]. The main advantage of such an approach is evident since, in healthy operation and by considering a balanced operation among the units, the torque control scheme should actively manage only the main subspace. Thus, allowing the use of most of the control schemes developed for three-phase motors [11], e.g., field-oriented control.

Unfortunately, the VSD approach can deal only with machines having a symmetrical or asymmetrical configuration of the stator winding [12]. Besides, if an open-three-phase fault occurs, the VSD-based algorithms must actively control the time-harmonic subspaces to keep the machine waveforms (e.g., phase-currents) balanced and within their boundaries. Hence, they require the implementation of specific control modules supported by dedicated fault-tolerant strategies [4],

and both often must be explicitly designed for the machine under consideration.

A viable alternative to the VSD-based control schemes is modular algorithms like those based on the multi-stator (MS) approach [1], [13]. In this case, the machine stator is considered as multiple three-phase winding sets interacting with each other and with an equivalent three-phase rotor. In this way, the flux and torque contributions of each winding set are highlighted. Therefore, the MS approach is suitable for implementing modular control schemes [5], [14]. Thus, performing both power-sharing strategies among the units and post-fault machine operation straightforwardly. Unlike the VSD approach, the MS can also deal with stator winding configurations different from the symmetrical or asymmetrical ones. However, the MS-based drive solutions require specific control schemes. Also, specific decoupling algorithms need to be implemented to prevent instability phenomena since the winding sets are coupled [1], [13], [15].

Recently, some attempts to combine the advantages of the VSD and MS approaches have been proposed [16]. In [17], [18], general solutions that consider a generic number of winding sets have been developed, leading to the definition of the decoupled MS (DMS) approach. According to [17], a DMS-based control scheme is structured like a VSD-based one but keeping the modularity features. Nevertheless, like the VSD-based schemes, the solution proposed in [17] requires implementing additional control modules to perform the post-fault drive operation.

Therefore, this paper aims at proposing a DMS-based control scheme that can perform the torque regulation of a multi-three-phase machine both in healthy and faulty operating conditions by using any of the conventional control algorithms for three-phase drives. According to the DMS approach [17], [18], the machine torque production is expressed using common- and differential- mode subspaces. Nevertheless, unlike [17], the torque regulation is obtained by actively controlling only the common-mode subspace, regardless of the machine operating condition (healthy or faulty). Therefore, compared to the control schemes based on VSD or DMS, the proposed control approach brings the following advantages and contributions:

- 1) The drive scheme does not require additional control modules to regulate the machine torque after an open-three-phase fault event. Hence, the simplicity of the control structure is preserved in any operating condition.
- 2) The control approach can be applied to any multi-three-phase machine, thus overcoming the VSD restrictions in terms of the symmetrical or asymmetrical stator winding configurations.

The proposed control approach has been used to implement a three-phase direct flux vector control (DFVC) scheme [19] for the regulation of the stator flux and torque of a multi-three-phase induction machine (IM). A 12-phase IM prototype with a quadruple-three-phase stator winding configuration, rated 10 kW at 6000 r/min, has been used to validate the proposed method.

The paper is organized as follows. Machine modeling is described in Section II, while the proposed control scheme is shown in Section III. Experimental results are illustrated in Section IV. Finally, Section V provides the paper conclusions.

II. MACHINE MODELING

In the following, the DMS approach is applied to a multi-three-phase squirrel-cage IM with p pole pairs and n winding sets. A sinusoidal distribution of the stator windings is assumed, i.e., they interact with each other and with the rotor only through the airgap field's fundamental spatial component. Mutual leakage fluxes and iron losses are not considered. The DMS model of a generic multi-three-phase IM is reported with more details in [17]. Therefore, the main results of [17] are summarized in the following to aid the understanding of the proposed control solution.

A. MS model of a multi-three-phase IM

The DMS approach is defined starting from the MS model of a generic multi-three-phase machine. According to [5], [17], the MS model of a multi-three-phase IM in stationary coordinates is obtained by applying the Clarke transformation to the electromagnetic equation system of each winding set [1]. The stationary equations are subsequently computed in rotating coordinates (xy) using the well-known rotational transformation [11]. In summary, the equation system of a generic winding set k ($k=1, \dots, n$) is computed as:

$$\begin{cases} \bar{v}_{sk,xy} = R_s \cdot \bar{i}_{sk,xy} + \frac{d}{dt} \bar{\lambda}_{sk,xy} + j \cdot \omega_{xy} \cdot \bar{\lambda}_{sk,xy} \\ \bar{\lambda}_{sk,xy} = k_r \cdot \bar{\lambda}_{r,xy} + L_{ls} \cdot \bar{i}_{sk,xy} + k_r \cdot L_{lr} \cdot \sum_{l=1}^n \bar{i}_{sl,xy} \\ \bar{0} = \frac{\bar{\lambda}_{r,xy}}{\tau_r} + \frac{d}{dt} \bar{\lambda}_{r,xy} + j \cdot \omega_{slip} \cdot \bar{\lambda}_{r,xy} - k_r \cdot R_r \cdot \sum_{l=1}^n \bar{i}_{sl,xy} \end{cases} \quad (1)$$

where $\bar{z}_{sk,xy} = [z_{sk,x} \ z_{sk,y}]^t$ and $\bar{z}_{sl,xy} = [z_{sl,x} \ z_{sl,y}]^t$ are generic stator vectors defined for the winding sets k ($k=1, \dots, n$) and l ($l=1, \dots, n$), respectively, both expressed in rotating coordinates (xy) ; $\bar{z}_{r,xy} = [z_{r,x} \ z_{r,y}]^t$ is a generic rotor vector expressed in rotating coordinates (xy) ; ω_{xy} and ω_{slip} are synchronous and slip speeds, respectively; v , i , and λ have the meaning of voltage, current, and flux linkage, respectively; R_s , L_{ls} , R_r , L_{lr} , k_r , and τ_r are the stator resistance, stator leakage inductance, rotor resistance, rotor leakage inductance, rotor coupling factor, and the rotor time-constant, respectively. Finally, j is the complex vector operator in matrix form, while $\bar{0} = [0 \ 0]^t$.

By performing the machine power balance [5], the overall electromagnetic torque T is computed as:

$$T = \sum_{k=1}^n T_k = \frac{3}{2} \cdot p \cdot \sum_{k=1}^n (\bar{\lambda}_{sk,xy} \times \bar{i}_{sk,xy}) \quad (2)$$

where T_k is the k -set torque contribution, while \times is the outer product operator. Based on (1), (2), it is noted how the MS approach highlights the stator flux and torque contribution of each winding set, resulting in suitable for implementing modular torque control schemes [5]. Further proof of the MS modularity is given in Fig. 2, showing the machine's equivalent circuit in stationary coordinates (L_m is the magnetizing inductance).

Nevertheless, from (1), it is noted how the winding sets are magnetically coupled with each other. Hence, demonstrating how it is necessary to implement dedicated decoupling algorithms in the MS-based control schemes [5], [20]. In this way, underdamped or even instability phenomena [15] are prevented.

In summary, the application of the DMS approach allows removing the MS couplings among the machine's winding sets. Nevertheless, compared to the VSD modeling, the modularity is preserved. Indeed, according to (3)-(5), the common- and differential- mode vectors are directly computed as numeric linear combinations of the MS variables belonging to the winding sets.

C. Adaptive DMS modeling

Compared to the VSD modeling, the DMS approach presents the following features:

- The decoupling transformation $[T_d]$ is defined regardless of the stator winding configuration since it is applied directly to the MS machine model. Therefore, the VSD limitation in terms of symmetrical or asymmetrical winding configurations is analytically overcome without using numerical approaches [21].
- No constraints exist on applying the decoupling transformation on a specific group of machine winding sets. Thus, modeling in terms of common- and differential- mode subspaces only the equation systems associated with such a group.

Such features become useful for control solutions that have to manage the operation of a multi-three-phase machine after an open-three-phase fault event. Indeed, if considering a balanced operation among the units under machine healthy conditions, both the VSD- and DMS- based control solutions perform the torque regulation by actively manage only their principal subspace, i.e., the main subspace for the VSD solutions, while common-mode subspace for the DMS ones. This allows the control implementation of a multi-three-phase machine using the control structures for three-phase motor drives [11].

Nevertheless, if an open three-phase fault event occurs, the VSD- and DMS- based control schemes need the active control of the secondary subspaces to keep the machine currents balanced and within their boundaries, as well as the continuity of the torque production. In other words, the implementation of additional control modules supported by dedicated fault-tolerant strategies to manage the time-harmonic subspaces for the VSD solutions [4], while the differential-mode subspaces for the DMS ones [17]. As a result, the simplicity that characterizes the VSD-based and DMS-based control schemes to the MS-based ones is lost.

The only solution to avoid the scenario mentioned above is to adapt the machine modeling by considering a stator winding configuration composed of the only healthy/active winding sets. According to the literature, such a solution is not viable for the VSD modeling since the post-fault configuration of the stator winding hardly ever satisfies the constraint of being symmetrical or asymmetrical [12], making not possible the definition of a dedicated VSD transformation unless using numerical methods [21].

Conversely, thanks to the aforementioned proprieties, the DMS-based control schemes always allow changing on-the-fly the decoupling transformation, i.e., adapting it to the post-fault configuration of the stator winding. Thus, defining a so-called adaptive DMS (A-DMS) modeling is possible. In the following, a practical example is reported to help the understanding.

Let's assume that the winding set 3 of an asymmetrical quadruple-three-phase machine becomes faulty. The post-fault configuration of the stator winding is shown in Fig. 4.

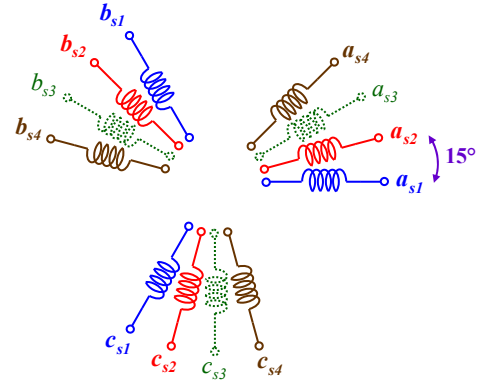

Fig. 4. Asymmetrical quadruple-three-phase winding configuration with winding set 3 faulty (dashed green windings).

According to the literature, a VSD transformation cannot be defined for this configuration since the latter is neither symmetrical nor asymmetrical. Conversely, if considering the DMS modeling, the decoupling transformation (4) can be easily adapted by setting the overall number of winding sets as $n = 3$, i.e.:

$$[T_d]_{n=3} = \frac{1}{3} \begin{bmatrix} 1 & 1 & 1 \\ \sqrt{2} & -1/\sqrt{2} & -1/\sqrt{2} \\ 0 & \sqrt{3/2} & -\sqrt{3/2} \end{bmatrix} \quad (10)$$

The adapted decoupling transformation is thus applied only to the healthy/active winding sets (1, 2, and 4) as:

$$\begin{Bmatrix} \bar{z}_{scm,xy} \\ \bar{z}_{sdm-1,xy} \\ \bar{z}_{sdm-2,xy} \end{Bmatrix} = [T_d]_{n=3} \cdot \begin{Bmatrix} \bar{z}_{s1,xy} \\ \bar{z}_{s2,xy} \\ \bar{z}_{s4,xy} \end{Bmatrix} \quad (11)$$

Therefore, the resulting A-DMS machine model corresponds to (7)-(9) but considering three winding sets ($n = 3$) and two differential-mode subspaces instead of the original three ones.

As a general rule, to each winding set that becomes faulty, a differential-mode subspace is removed. In parallel, the definition of the common-mode subspace and the remaining differential-mode ones is adapted according to (4), but by considering the number of healthy/active sets n_a instead of the effective/rated machine ones n . In practical terms, the A-DMS machine model is obtained by considering only the healthy/active sets in (3) and by setting $n = n_a$ in (4), (5), and (7)-(9). The application scheme of the adaptive decoupling transformation to a generic variable z (v, i, λ) is shown in Fig. 5, for better understanding.

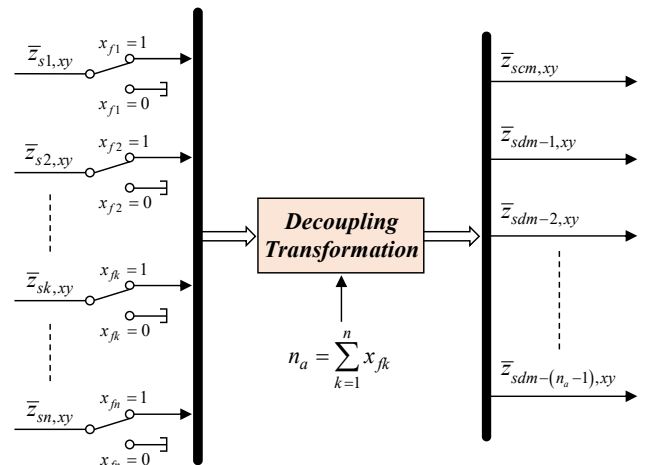

Fig. 5. Application scheme of the adaptive decoupling transformation.

The variable x_{jk} stands for the status (0=faulty,1=healthy) of the generic winding set k ($k=1,\dots,n$). It is noted that if the generic winding set k is faulty, the related MS variables are automatically ruled out from the computation of the common- and differential-mode vectors. The advantages of the A-DMS approach are thus evident if it is always assumed a balanced operation among the healthy winding sets, regardless of the machine operating conditions (healthy or faulty). This scenario is typical of high-power applications (e.g., oil and gas [8]). For such cases, only the common-mode subspace is permanently active. Conversely, the differential-mode currents are always zero, regardless of the machine operating conditions (healthy or faulty) and the effective number of healthy/active sets.

In summary, an A-DMS-based drive solution can perform the torque control of a multi-three-phase machine both in healthy and faulty operation by actively controlling only the common-mode subspace, allowing the use of any control schemes for the three-phase drives without the need for additional control modules or specific fault-tolerant control strategies. In this way, the simplicity of the control structure is preserved in any operating condition. The only constraint is to operate the healthy winding sets always balanced with each other; this scenario usually happens in practice since the machine efficiency is maximized [6].

III. CONTROL SCHEME

In this paper, the A-DMS approach is proposed to implement the three-phase direct flux vector control (DFVC) scheme [19] to regulate the stator flux and torque of a multi-three-phase IM.

According to [19], the three-phase DFVC scheme is implemented in rotating stator flux coordinates (dqs). Therefore, the ds -axis position ϑ_s corresponds with that of the stator flux vector, as schematically shown in Fig. 6. Since the (dqs) frame is adopted, the synchronous speed ω_s is thus defined as the angular speed of the stator flux vector to the stationary α -axis. Finally, the machine load-angle δ is defined as the ds -axis position to the rotor flux vector (see Fig. 6).

For a multi-three-phase IM, n stator flux vectors are defined (one for each winding set). Therefore, a three-phase DFVC scheme should be implemented to control each unit. This solution is mandatory if power-sharing strategies among the units are performed since significant unbalances between the winding sets in terms of flux, currents, or both are potentially introduced [5], [6]. Thus, the machine presents n different stator flux frames in these operating conditions, making the modular control schemes like the MS-based DFVC the only viable solution [5].

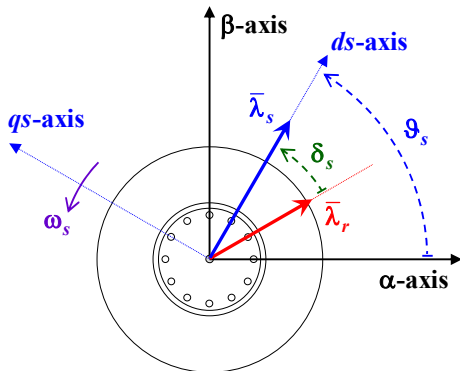

Fig. 6. Rotating stator flux frame (dqs) for a three-phase IM.

Since both DMS and A-DMS modeling approaches can perform their decoupling action only if a single reference frame is adopted, the A-DMS-based DFVC scheme proposed in this paper can manage only a balanced operation among the healthy units. In other terms, the healthy units must operate by sharing the same values of stator flux amplitude and torque contribution. Indeed, as demonstrated in [5], the stator flux vectors of the healthy units are overlapped in these operating conditions [17], allowing the definition of a unique active frame (dqs), i.e., an equivalent three-phase machine.

A. Flux and torque equations

Based on the A-DMS model, the flux and torque productions are performed in the common-mode subspace. Therefore, by considering (7) in the active frame (dqs), i.e., $\bar{\lambda}_{scm,dqs}=[\lambda_{scm} \ 0]^t$, the ds -axis voltage equation is computed as:

$$v_{scm,ds} = R_s \cdot i_{scm,ds} + \frac{d}{dt} \lambda_{scm} \quad (12)$$

It is noted that the flux amplitude of the healthy winding sets is regulated by acting on the ds -axis common-mode voltage $v_{scm,ds}$. The machine torque can be directly regulated by acting on the qs -axis common-mode current $i_{scm,qs}$ since it has the meaning of the machine's torque-producing current. The proof of this is given by computing (9) in the active frame (dqs), leading to as follows:

$$T = 1.5 \cdot n_a \cdot p \cdot \lambda_{scm} \cdot i_{scm,qs} \quad (13)$$

Finally, the qs -axis common-mode current $i_{scm,qs}$ is regulated by acting on the qs -axis common-mode voltage $v_{scm,qs}$, as for the conventional three-phase DFVC scheme [19].

B. Stator flux and torque-producing current references

The control solution proposed in this paper is similar to that reported in [17], where a DMS-based DFVC is presented. The main difference consists in how the post-fault operation of the machine is performed. In [17], the decoupling transformation $[T_d]$ has been kept invariant regardless of the machine operating condition (healthy or faulty). Thus, the common- and differential- mode vectors are expressed as a function of the variables belonging to both the healthy and faulty winding sets. Therefore, to perform the machine's post-fault operation, the computation of both the reference- and observed- value of the flux amplitude belonging to each faulty winding set is necessary [17]. Also, such values must be computed in the reference frame of the active units (dqs). Finally, since both the references of flux amplitude and torque-producing current belonging to the faulty winding sets differ from those of the healthy ones, the active control of the differential-mode subspaces is automatically performed after applying the decoupling transformation [17]. In this way, the phase-currents of the healthy sets are kept balanced and within their boundaries. In summary, it is evident how the DMS-based DFVC scheme requires implementing specific control modules to perform the machine's post-fault operation properly. More details are reported in [17].

Unlike the DMS-based DFVC scheme, the proposed solution is based on A-DMS modeling. Therefore, if an open-three-phase fault occurs, the definition of the common- and differential- mode subspaces is adapted to consider the stator winding's post-fault configuration. In this way, the common-mode references of flux amplitude and torque-producing current are computed easily. If the machine is operated below the base speed, the reference of the common-mode flux λ_{scm}^* (corresponding to that of each healthy winding set) is usually set equal to the rated value, as in (14).

$$\lambda_{scm}^* = \lambda_{s, rated} \quad (14)$$

It is highlighted that the flux reference can be optimized by following the maximum-torque per ampere profile of the machine [22]. In this way, the overload capability of the drive is maximized both in healthy and faulty operation, as the overall Joule losses are minimized.

Since a balanced operation among the units is considered, the torque contributions of the healthy winding sets are identical to each other. Hence, the reference of the common-mode torque-producing current $i_{scm,qs}^*$ (corresponding to that of each healthy winding set) is computed according to (13) as:

$$i_{scm,qs}^* = T^* / (1.5 \cdot n_a \cdot p \cdot \lambda_{scm}^*) \quad (15)$$

where T^* is the machine torque reference. Finally, according to the A-DMS approach, the references of flux amplitude and qs -axis current of each differential-mode subspace u ($u=1, \dots, n_a$) are permanently set to zero regardless of the machine operating conditions (healthy or faulty):

$$\lambda_{sdm-u}^* = 0, \quad i_{sdm-u,qs}^* = 0 \quad \forall u = 1, \dots, n_a \quad (16)$$

C. Stator flux observer

As for the DMS-based DFVS scheme, the proposed solution needs to implement a flux observer to estimate the stator flux vectors of all winding sets in terms of amplitude and angular position. In this way, the common- and differential-mode values of the stator fluxes amplitudes can be computed, as well as the active stator frame (dqs) is obtained. In summary, the proposed flux observer is the same as that implemented for both the MS-based and DMS-based DFVC schemes [5], [17]. More details concerning its design are thus reported in [5].

D. Adaptive decoupling transformation

The proposed drive scheme regulates the machine torque through the direct control of the common-mode values of flux amplitude and torque-producing current. In parallel, the flux amplitude and qs -axis current of each differential-mode subspace are controlled at zero. Therefore, the adaptive decoupling transformation is applied to the flux amplitudes and torque-producing currents of the healthy winding sets, leading to the computation of the corresponding values of common- and differential-mode. The application of the adaptive decoupling transformation on the estimated stator flux amplitudes (superscript $\hat{}$) and measured torque-producing currents is shown in Fig. 7. For the sake of simplicity, this paper assumes that the units' states x_{fk} ($k=1, \dots, n$) are input signals of the control scheme.

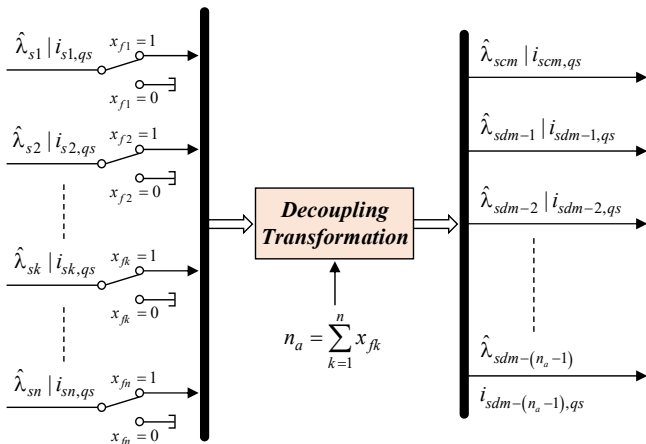

Fig. 7. Adaptive computation of the common- and differential modes of flux amplitudes and torque-producing currents.

E. Flux and torque control

The flux and torque control of the machine is performed by actively controlling the common-mode subspace, i.e., common-mode values of flux amplitude and torque-producing current. In this paper, the use of conventional proportional-integral (PI) controllers is proposed (see Fig. 8) since the common-mode variables are dc quantities in steady-state conditions [17]. The number of PI regulators performing the control of the differential-mode subspaces depends on the machine operating conditions. Indeed, according to the A-DMS modeling, the number of existing differential-mode subspaces corresponds to that of healthy winding sets n_a . Therefore, in the extreme case in which only one winding set is healthy, the machine control is performed only through the common-mode regulators since the differential-mode subspaces do not exist anymore. In other words, the operation of the multi-three-phase machine collapse in its simplest case, an actual three-phase motor. Thus, only two PI regulators to perform the torque control are required.

The outputs of the PI controllers correspond with the common- $\bar{v}_{scm,dqs}^*$ and differential- $\bar{v}_{sdm-u,dqs}^*$ ($u=1, \dots, n_a-1$) mode reference voltages (see Fig. 8). Hence, the inverse decoupling transformation is applied to get the healthy units' reference voltages in the active (dqs) frame $\bar{v}_{sk,dqs}^*$ ($k=1, \dots, n$), as shown in Fig. 9. Finally, according to [5], the computation of each unit's inverter commands is performed.

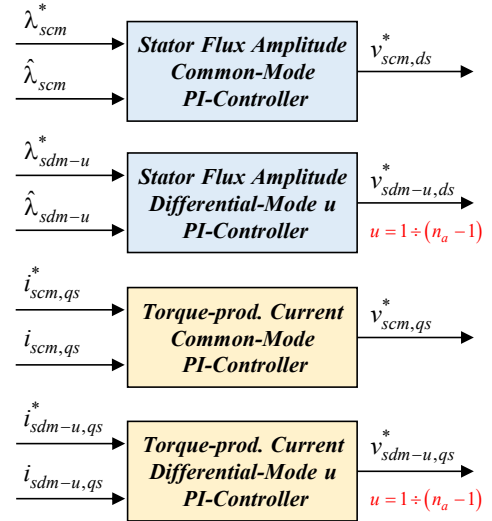

Fig. 8. Adaptive regulation of the common- and differential- modes of fluxes amplitudes and torque-producing currents using PI controllers.

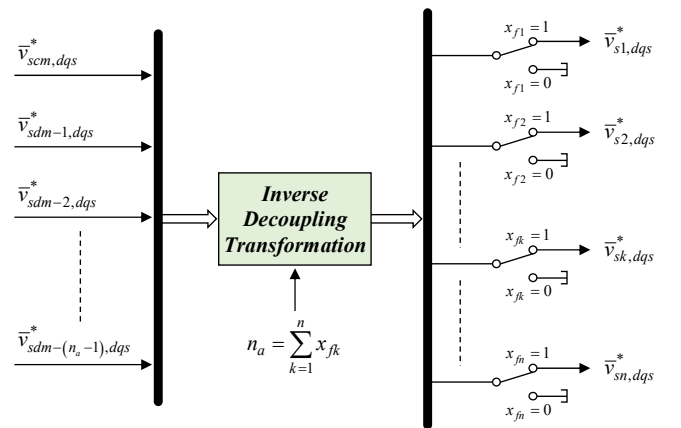

Fig. 9. Computation of the reference voltages of the healthy units by using the inverse adaptive decoupling transformation.

IV. EXPERIMENTAL VALIDATION

The validation of the proposed control solution has been carried out on a 12-phase asymmetrical IM with four three-phase winding sets shifted by 15 electrical degrees (full-pitch windings with one slot/pole/phase). A schematic view of the stator winding's configuration is shown in Fig. 10, while Table I reports the primary machine data.

A. Test rig

The IM under test has been mounted on a test rig for validation purposes. The rotor shaft has been coupled to a driving machine acting as prime mover, as shown in Fig. 11.

The power converter consists of four independent three-phase inverter power modules (100 A, 1200 V) fed at 270 V by a bidirectional dc source. Both the switching- and sampling- frequencies have been set at 5 kHz to provide a compatible scenario with the industrial implementations. Finally, the digital controller is the dSPACE[®] DS1103 fast prototyping board, while the control algorithm has been developed in the C-code environment.

TABLE I. MACHINE PRIMARY DATA

Electrical Data	
Phase Number	12 (4×3-phase)
Pole number	4
Rated power	10 kW
Rated speed	6000 r/min
Rated phase-voltage	115 Vrms
Rated phase current	10 Arms
Machine Parameters	
Stator resistance R_s	145 mΩ
Stator leakage inductance L_{ls}	0.94 mH
Magnetizing inductance L_m	4.3 mH
Rotor resistance R_r	45 mΩ
Rotor leakage inductance L_{lr}	0.235 mH
Rated stator flux amplitude $\lambda_{s,rated}$	115 mVs

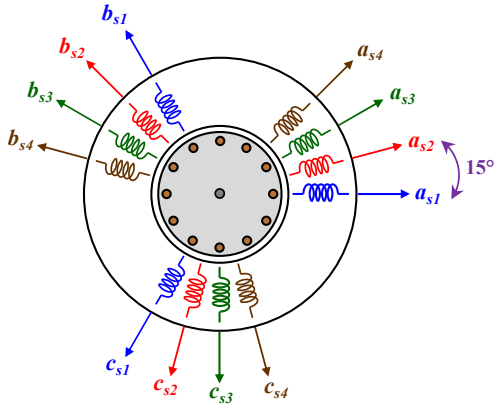

Fig. 10. Asymmetrical 12-phase IM using a quadruple-three-phase stator winding configuration.

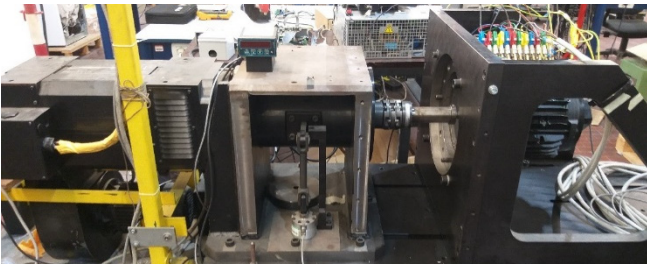

Fig. 11. View of the IM under test (right) and the driving machine (left).

B. Experimental results

The IM has been tested as a generator in the torque control mode. The validation of the proposed control scheme has been carried out by testing the fault-tolerance capability of the drive. Starting from rated generating conditions (-6000 r/min, 16 Nm), the inverter power module 3 has suddenly been turned off. The fault of a power module may produce this event. The experimental results are shown in Figs. 12 – 15.

Fig. 12 shows the first phase-current 'a' of each of the four three-phase sets before and after the fault. It is noted that the currents of the healthy units must increase to preserve the torque and machine flux. However, according to Figs. 14 – 15, only the common-mode subspace is actively controlled before and after the fault event. According to (4), it is pointed out that the physical meaning of each common-mode variable consists of the average value of the respective components belonging to the healthy winding sets. Therefore, referring to Figs. 13 – 14, it is noted that the flux amplitude of the healthy sets (1,2,4) is kept at the rated value (115 mVs), while the common-mode torque-producing current increases from 13.2 to 17.7 A to satisfy the torque request (see Fig. 15).

Due to machine asymmetries related to the winding set 2 (see Fig. 13), it is noted that slight disturbances characterize the torque-producing current component belonging to the second differential-mode subspace (see Fig. 15).

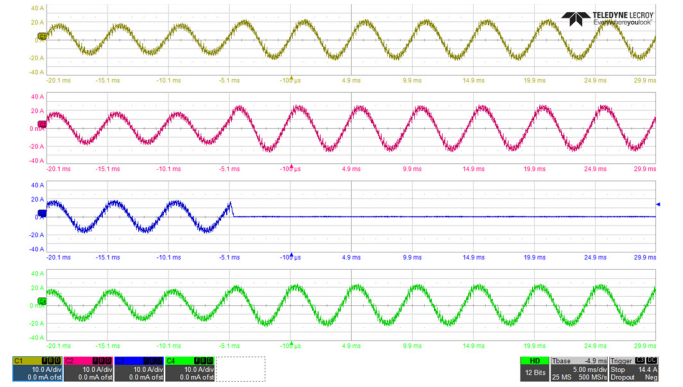

Fig. 12. Inverter 3 shut-off in generation mode (-6000 r/min, 16 Nm). Ch1: i_{as1} (10 A/div), Ch2: i_{as2} (10 A/div), Ch3: i_{as3} (10 A/div), Ch4: i_{as4} (10 A/div). Time resolution: 5 ms/div.

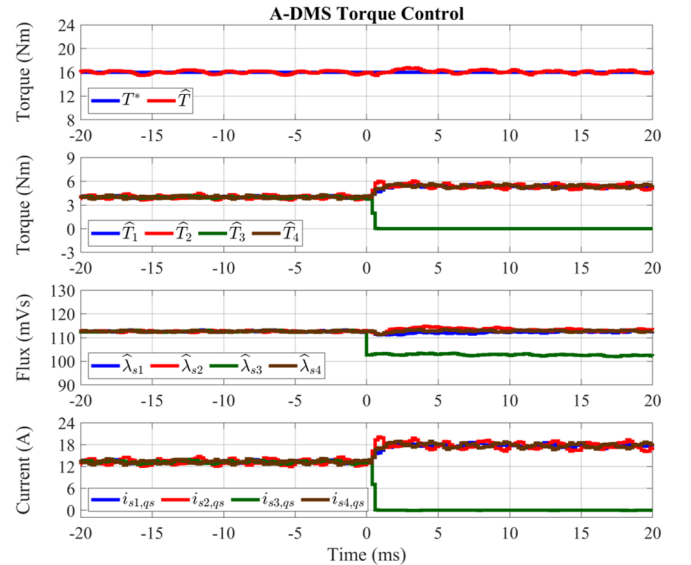

Fig. 13. Inverter 3 shut-off in generation mode (-6000 r/min, 16 Nm). Time profiles of the MS variables in terms of torque (Nm), flux amplitudes (mVs), and torque-producing currents (A).

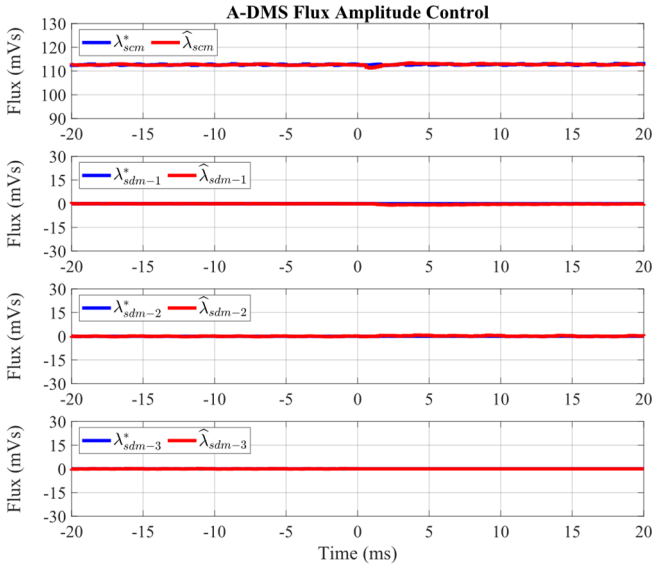

Fig. 14. Inverter 3 shut-off in generation mode (-6000 r/min, 16 Nm). Common- and differential- mode control of the fluxes amplitudes.

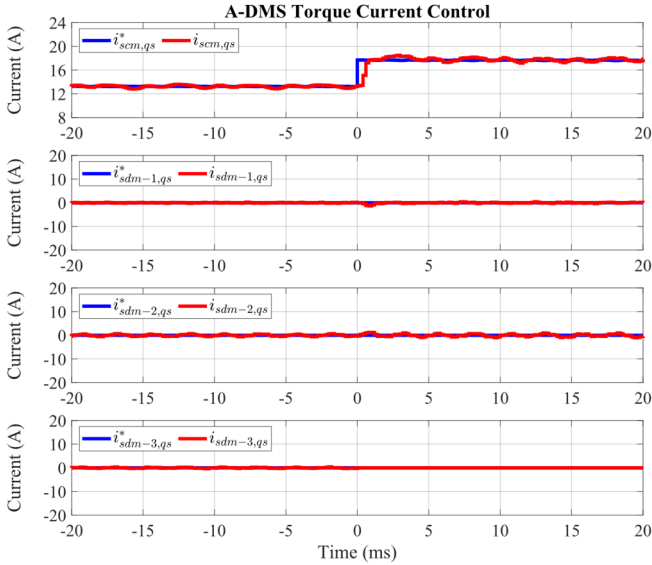

Fig. 15. Inverter 3 shut-off in generation mode (-6000 r/min, 16 Nm). Common- and differential- mode control of the torque-producing currents.

However, the phase-currents of the healthy units are not affected by these machine asymmetries since they exhibit a sinusoidal waveform (see Fig. 12). In summary, thanks to the A-DMS control approach, an open-three-phase fault event simply leads to a change in the reference of the common-mode torque-producing current. The adaptive decoupling transformation automatically performs such a change without implementing any control strategies or additional control modules involving the differential-mode subspaces.

V. CONCLUSION

The paper proposes an innovative control approach to perform the torque regulation of a multi-three-phase induction machine (IM) both in healthy and faulty operation (fault of one or more three-phase inverter modules) using any of the control schemes normally employed for three-phase drives.

A novel reference transformation, based on the common- and differential- mode modeling, has been used to implement the three-phase direct flux vector control scheme to regulate both the stator flux and torque of a multi-three-phase IM.

The experimental validation has been carried out on a 12-phase IM that uses a quadruple-three-phase stator winding configuration. Experimental results validate the proposed control solution both in healthy and faulty machine operation.

ACKNOWLEDGMENT

The authors would like to acknowledge the financial support from the Power Electronics Innovation Center (PEIC) of the Politecnico di Torino (www.peic.polito.it).

REFERENCES

- [1] R. Bojoi *et al.*, ‘Multiphase electrical machines and drives: A viable solution for energy generation and transportation electrification’, in *2016 EPE*, Oct. 2016, pp. 632–639.
- [2] W. Cao *et al.*, ‘Overview of Electric Motor Technologies Used for More Electric Aircraft (MEA)’, *IEEE Trans. Ind. Electron.*, vol. 59, no. 9, pp. 3523–3531, Sep. 2012.
- [3] E. Levi, ‘Multiphase Electric Machines for Variable-Speed Applications’, *IEEE Trans. Ind. Electron.*, vol. 55, no. 5, pp. 1893–1909, May 2008.
- [4] M. J. Duran and F. Barrero, ‘Recent Advances in the Design, Modeling, and Control of Multiphase Machines—Part II’, *IEEE Trans. Ind. Electron.*, vol. 63, no. 1, pp. 459–468, Jan. 2016.
- [5] S. Rubino *et al.*, ‘Modular Stator Flux and Torque Control of Multi-Three-Phase Induction Motor Drives’, *IEEE Trans. Ind. Appl.*, vol. 56, no. 6, pp. 6507–6525, Nov. 2020.
- [6] I. Zoric, M. Jones, and E. Levi, ‘Arbitrary Power Sharing Among Three-Phase Winding Sets of Multiphase Machines’, *IEEE Trans. Ind. Electron.*, vol. 65, no. 2, pp. 1128–1139, Feb. 2018.
- [7] I. Zoric, M. Jones, and E. Levi, ‘Voltage balancing control of a symmetrical nine-phase machine with series-connected DC links’, in *2017 IEEE ISIE*, Jun. 2017, pp. 1052–1057.
- [8] A. Tessarolo, G. Zocco, and C. Tonello, ‘Design and Testing of a 45-MW 100-Hz Quadruple-Star Synchronous Motor for a Liquefied Natural Gas Turbo-Compressor Drive’, *IEEE Trans. Ind. Appl.*, vol. 47, no. 3, pp. 1210–1219, May 2011.
- [9] Y. Zhao and T. A. Lipo, ‘Space vector PWM control of dual three-phase induction machine using vector space decomposition’, *IEEE Trans. Ind. Appl.*, vol. 31, no. 5, pp. 1100–1109, Sep. 1995.
- [10] E. Levi *et al.*, ‘Multiphase induction motor drives - a technology status review’, *IET Electr. Power Appl.*, vol. 1, no. 4, pp. 489–516, Jul. 2007.
- [11] P. Krause *et al.*, *Analysis of Electric Machinery and Drive Systems*. John Wiley & Sons, 2013.
- [12] I. Zoric, M. Jones, and E. Levi, ‘Vector space decomposition algorithm for asymmetrical multiphase machines’, in *2017 Ee*, 2017, pp. 1–6.
- [13] R. H. Nelson and P. C. Krause, ‘Induction Machine Analysis for Arbitrary Displacement Between Multiple Winding Sets’, *IEEE Trans. Power Appar. Syst.*, vol. PAS-93, no. 3, pp. 841–848, May 1974.
- [14] S. Rubino *et al.*, ‘Vector Control of Multiple Three-Phase Permanent Magnet Motor Drives’, in *IECON 2018*, Oct. 2018, pp. 5866–5871.
- [15] Y. Hu *et al.*, ‘Comparison of Two-Individual Current Control and Vector Space Decomposition Control for Dual Three-Phase PMSM’, *IEEE Trans. Ind. Appl.*, vol. 53, no. 5, pp. 4483–4492, Sep. 2017.
- [16] J. Karttunen *et al.*, ‘Decoupled Vector Control Scheme for Dual Three-Phase Permanent Magnet Synchronous Machines’, *IEEE Trans. Ind. Electron.*, vol. 61, no. 5, pp. 2185–2196, May 2014.
- [17] S. Rubino *et al.*, ‘Decoupled and Modular Torque Control of Multi-Three-Phase Induction Motor Drives’, *IEEE Trans. Ind. Appl.*, vol. 56, no. 4, pp. 3831–3845, 2020.
- [18] S. Rubino *et al.*, ‘A Novel Matrix Transformation for Decoupled Control of Modular Multiphase PMSM Drives’, *IEEE Trans. Power Electron.*, vol. 36, no. 7, pp. 8088–8101, Jul. 2021.
- [19] G. Pellegrino *et al.*, ‘Unified Direct-Flux Vector Control for AC Motor Drives’, *IEEE Trans. Ind. Appl.*, vol. 47, no. 5, pp. 2093–2102, 2011.
- [20] S. Rubino *et al.*, ‘Modular Stator Flux and Torque Control of Multiphase Induction Motor Drives’, in *2019 IEEE IEMDC*, San Diego, USA, 2019, pp. 531–538.
- [21] R. Kianinezhad *et al.*, ‘Modeling and Control of Six-Phase Symmetrical Induction Machine Under Fault Condition Due to Open Phases’, *IEEE Trans. Ind. Electron.*, vol. 55, no. 5, pp. 1966–1977, May 2008.
- [22] S. Rubino, R. Bojoi, M. Mengoni, and L. Zarri, ‘Optimal flux selection for multi three-phase machines in normal and fault conditions’, in *2017 IEEE IEMDC*, May 2017, pp. 1–8.