

Effect of friction on a crashworthiness test of flat composite plates

Original

Effect of friction on a crashworthiness test of flat composite plates / Vigna, Lorenzo; Calzolari, Andrea; Galizia, Giuseppe; Belingardi, Giovanni; Paolino, Davide Salvatore. - In: FORCES IN MECHANICS. - ISSN 2666-3597. - ELETTRONICO. - 6:(2022). [10.1016/j.finmec.2021.100070]

Availability:

This version is available at: 11583/2949124 since: 2022-01-11T23:07:37Z

Publisher:

Elsevier

Published

DOI:10.1016/j.finmec.2021.100070

Terms of use:

This article is made available under terms and conditions as specified in the corresponding bibliographic description in the repository

Publisher copyright

Elsevier postprint/Author's Accepted Manuscript

© 2022. This manuscript version is made available under the CC-BY-NC-ND 4.0 license
<http://creativecommons.org/licenses/by-nc-nd/4.0/>. The final authenticated version is available online at:
<http://dx.doi.org/10.1016/j.finmec.2021.100070>

(Article begins on next page)

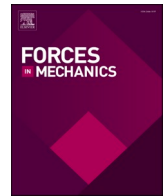

Effect of friction on a crashworthiness test of flat composite plates

Lorenzo Vigna^{a,*}, Andrea Calzolari^b, Giuseppe Galizia^b, Giovanni Belingardi^a,
Davide Salvatore Paulino^a

^a Department of Mechanical and Aerospace Engineering, Politecnico di Torino, Turin, Italy

^b ITW Test And Measurement Italia S.r.l.-Instron CEAST Division, Pianezza, TO, Italy

ARTICLE INFO

Keywords:

Crashworthiness
Composites
Specific energy absorption
Impact testing
Friction

ABSTRACT

The diffusion of fiber reinforced plastics in crashworthiness applications is continuously growing thanks to the excellent balance between high mechanical performances and low weight, resulting in most cases in a Specific Energy Absorption (SEA) of composite structures higher than that of the corresponding metallic structures. In this paper, a new fixture to test composite plates applying an in-plane load has been used to investigate the effect of the impact velocity and of the friction caused by the fixture on the SEA of carbon fiber reinforced epoxy plates. The tests have been carried out using a drop tower testing machine and the effect of the friction has been studied varying the clamping force given by the fixture. Splaying is the main failure mechanism found in the specimens during the tests; SEA values (43.6 kJ/kg in average) increase with the clamping force due to the higher friction level induced by higher clamping force; impact velocity does not significantly influence the results. To avoid an overestimation of the SEA due to the excessive friction force (+5.6% when the clamping force increases from 0.8 kN to 8 kN), a Polytetrafluoroethylene (PTFE) coating has been applied to the anti-buckling supports to reduce the friction. The effect of this modification has been studied by carrying out a new test in which the specimen slides between the anti-buckling supports with a given clamping force. A significant reduction (-48% with same clamping force) of the friction force is obtained when the lubricant is applied.

1. Introduction

Composite materials are very effective for crashworthiness because of the high level of energy absorption during crash and the low density. This makes them a better choice than metals in many crashworthiness applications [1–3]. The behavior of composite materials in crash conditions has been deeply investigated in the past decades, and several testing campaigns have been carried out to compare different materials. A wide literature on crash mechanisms [4–6] and energy-absorbing elements [7–11] is available, but the comparison between results obtained by different studies is difficult. The reason is that at present international standards for composite materials are devoted to damaging conditions (indentation and out-of-plane impact, Compression After Impact test, Charpy impact strength test) that are not suited to evaluate completely the actual crashworthiness of the material [12]. In the literature, it is possible to find tests carried out on different coupon shapes (tubes, cones, open channels, sinusoidal, flat plates) and on various examples of crash absorbers. However, the different geometries make the comparison of the results obtained by these studies a hard task, because different

failure modes are obtained with the different specimen geometries, and it is known that the different failure modes have different efficiencies in terms of energy absorption [5].

The idea of using flat specimens to characterize the in-plane crash behavior of composites was first proposed by Lavoie and Morton [13]. A specimen machined from a flat plate is not affected by geometrical effects, cost-effective and simple to manufacture but has the drawback of requiring a fixture to avoid buckling, which is an unwanted failure mode since it drastically reduces the amount of absorbable energy in crash events. The results obtained by Lavoie and Morton using a first solution of anti-buckling fixture showed higher Specific Energy Absorption (SEA) than that obtained with other specimen shapes. This effect was found to be due to excessive constraining of the specimen. This issue was addressed in several subsequent researches that proposed different solutions like the ones from Feraboli [14], the company Engenuity [11,15] and other researchers [9,16–19]. In some cases, flat specimens were used to investigate failure modes that differ from splaying, like tearing [15,20,21], or for material card parameters identification [22]. None of the various specimen shapes or of the cited testing fixtures is today

* Corresponding author.

E-mail address: lorenzo_vigna@polito.it (L. Vigna).

<https://doi.org/10.1016/j.finmec.2021.100070>

Received 29 October 2021; Received in revised form 31 December 2021; Accepted 31 December 2021

Available online 3 January 2022

2666-3597/© 2022 The Authors.

Published by Elsevier Ltd.

This is an open access article under the CC BY-NC-ND license

(<http://creativecommons.org/licenses/by-nc-nd/4.0/>).

recognized as a standard setup for testing the in-plane crashworthiness of composite materials; this issue is slowing down the diffusion of composites for crashworthiness applications because it represents a lack in the material characterization procedure and causes difficult comparisons of the performance of different materials. A new fixture for crash tests on flat coupons has been designed within the frame of a collaboration between Politecnico di Torino and the companies Instron and CRF [23,24], and is used in this research to characterize the crash behavior of a carbon fiber/epoxy laminate.

The goal of the present work is to study the effect of two parameters, i.e., impact velocity and friction induced by the testing fixture, on the SEA of carbon fiber specimens. The effect of the impact velocity is investigated because it is expected to cause different energy absorptions due to the strain rate effect, which typically affects polymers behavior [25]. The second parameter taken in consideration is the clamping force, that causes the absorption of a portion of the impact energy as a consequence of friction in the sliding contact between the specimen and the supporting columns of the anti-buckling device. This factor must be controlled and reduced as much as possible to avoid an overestimation of the crash force and energy absorption of the specimen, which is a known issue in several testing procedures [26,27]. To better understand the effect of the friction, available standard friction tests (e.g. Pin-on-Disk method according to ASTM G99 [28] or reciprocating Ball-on-Flat apparatus according to ASTM G133 [29]) were not employed because our interest is on the present specific device. It is known that friction coefficients can change using different testing setups and testing conditions, as the friction must be considered a system property [30]. The testing setup has then been modified to carry out a new kind of test in which the specimen does not crash, but it slides along the anti-buckling supports with a given clamping force, in a condition similar to the setup presented by Schön [31]. In this way, it is possible to evaluate the portion of force measured in the crash tests which is not due to the failure of the material but to the slide with friction along the anti-buckling columns. As a final phase of the research, lubrication has been applied on the anti-buckling columns to reduce the friction force. Between the different available lubricants (oils, greases, solid lubricants) a dry Polytetrafluoroethylene (PTFE) lubricant was chosen for its good adhesion to the steel surface and absence of drops and deposits on other parts of the fixture. The effect of the lubricant in terms of reduction of the friction force is measured using the same testing setup.

2. Materials and methods

2.2. Specimen

The crash tests were performed with a carbon fiber reinforced epoxy composite laminate. The laminate consists of four pre-impregnated layers of Microtex GG630, that consists of a carbon fiber twill fabric

having a weight of 630 g/m² coated with E3-150 high toughness epoxy resin (resin content is 37% in volume). The layup direction was 0°/90° for all the layers, that, during their manufacturing process, were positioned on a steel plate and then covered by the vacuum bag. The layup preparation and autoclave cure of the material were performed by the company Carbon Mind srl. Curing process was made according to the pressure and temperature profiles in Fig.1, obtaining an average thickness of the cured plates of 2.6 mm, and a density of 1.47 kg/dm³. After the curing process, the plates were cut by milling to obtain the rectangular specimens, with dimensions 150 × 100 mm, having a saw-tooth on one of the edges with function of failure initiator (Fig. 2a) as proposed in other researches [13,14].

The friction tests were performed using a NEMA FR4 glass fiber fabric coated with epoxy resin [32]. The specimen is a rectangular flat plate having dimensions 150 × 100 mm and a thickness of 3 mm. The saw-teeth trigger is not machined because the test requires only to have the specimen sliding between the supporting columns and not its failure.

2.2. Testing setup for crashworthiness tests

The anti-buckling fixture used in this research (Fig. 2b) was designed to perform in-plane compression tests on flat composite samples in impact conditions, with a drop tower testing machine, and in quasi-static conditions, with a universal testing machine. The device is equipped with a clamping system that holds the specimen in position and has anti-buckling function through six vertical columns (four external columns that support the specimen for its full length and two shorter columns located in the center of the specimen). The saw-tooth edge of the specimen is positioned downward in contact with a horizontal steel plate, that corresponds to the surface against which the failure of the specimen takes place. A height of the specimen of 10 mm from the lower plate is left unsupported to allow fronds formation during failure. The upper edge of the specimen is left free and gets in contact with the loading element, that corresponds to a flat disk connected to the dropped mass. Four screws (two for each side) provide the clamping force, required to avoid buckling. The screws are fastened using a dynamometric wrench to control the torque and consequently set the desired clamping force.

The tests were performed with an Instron 9450 drop tower testing machine, that allowed to acquire the crash force with a load cell that is a part of the dropping mass. The dropped mass can be increased or decreased, and the falling height modified to reach the desired combination of impact velocity and energy. The dropped mass is guided by two columns to assure and maintain the correct positioning respect to the specimen (Fig. 3). For these tests, a strain-gage instrumented tup with maximum load capacity of 222 kN, and a signal sampling rate of 1 MHz were used. The tup is designed to be not influenced by lateral loads thanks to the strain gauges electrically connected to form a full

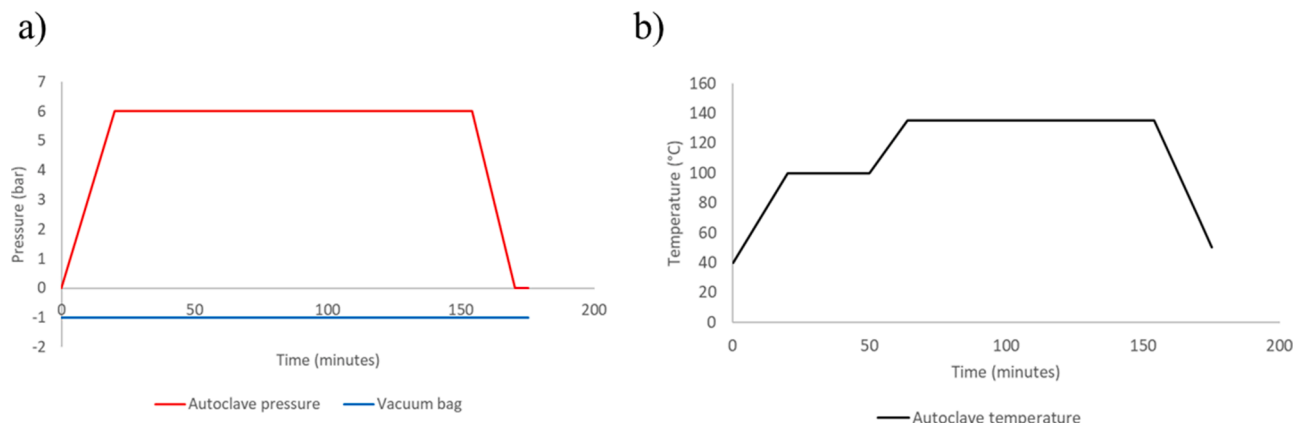

Fig. 1. Cure cycle of the carbon fiber reinforced epoxy composite laminate: a) pressure; b) temperature.

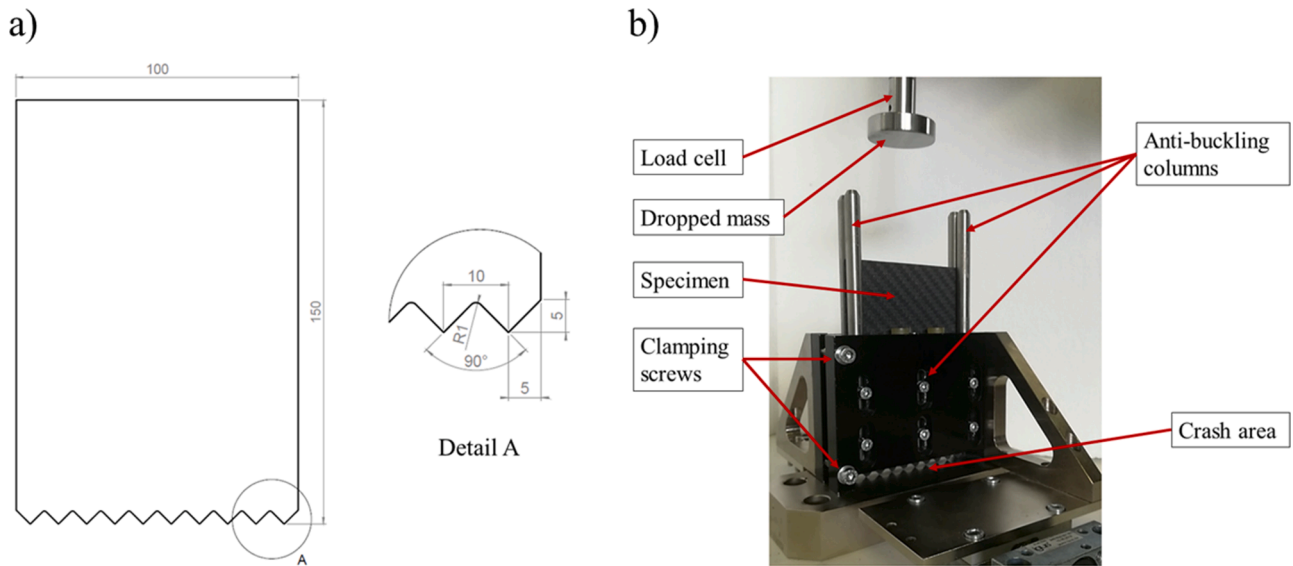

Fig. 2. a) Geometry of the carbon fiber/epoxy specimens used for this research, with dimensions in mm; the plate thickness is 2.6 mm. b) Anti-buckling fixture for compression crash testing of composite flat plates in impact conditions.

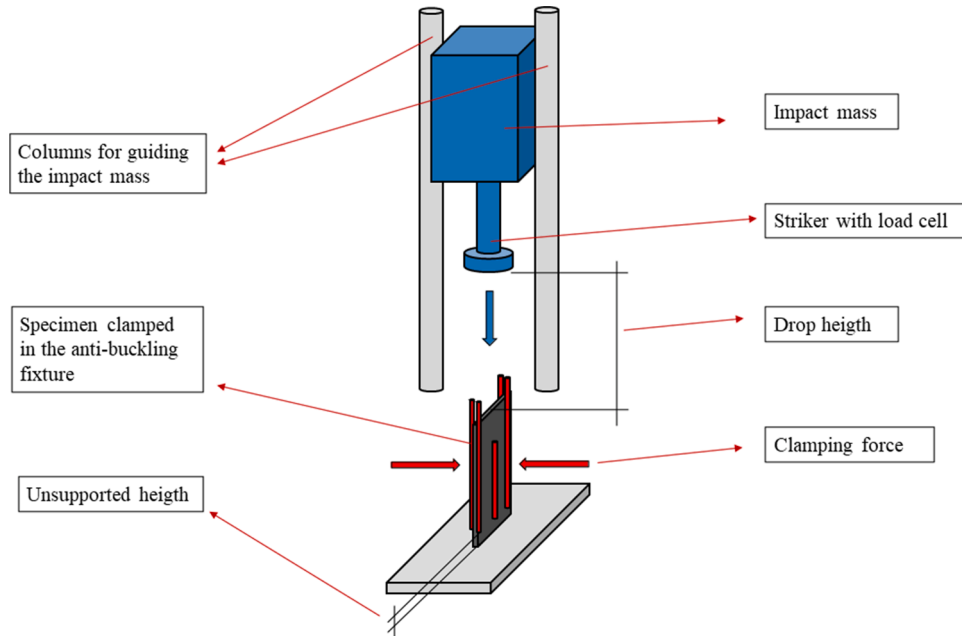

Fig. 3. Schematic representation of the testing setup.

Wheatstone bridge circuit. The test was recorded using a Photron FASTCAM Mini AX high speed camera that allowed to observe the behavior of the testing fixture and capture the failure process with a resolution of 1024×1024 pixels and a frame rate of 6400 fps (Fig. 4a). From the force signal, the force-displacement curves (Fig. 4b) were obtained by double integration according to:

$$\delta(t) = \delta_0 + v_0 t + \frac{gt^2}{2} - \int_0^t \left(\int_0^t \frac{F(t)}{m} dt \right) dt \quad (1)$$

where $F(t)$ is the acquired force signal, δ_0 and v_0 are the initial displacement and velocity, t is the time from the beginning of the impact, m is the dropped mass and g the acceleration of gravity. The initial velocity v_0 is measured by a photoelectric sensor positioned right before the dropped mass gets in contact with the specimen. In the range

of interest for SEA calculation, the difference between the calculated displacement and the displacement measured by image tracking from high-speed videos was limited and always below 1 mm.

The displacement $\delta(t)$ and the absorbed energy E (which comes from the integration of the force-displacement curve) were calculated by the Instron Bluehill Impact software, that saved an export file containing time, force and displacement values. The exported data were then analyzed by a Matlab code that computed the Specific Energy Absorption (SEA) as:

$$SEA = \frac{E}{\rho A (\delta_f - \delta_i)} = \frac{\int_{\delta_i}^{\delta_f} F(\delta) d\delta}{\rho A (\delta_f - \delta_i)} \quad (2)$$

where E represents the energy absorbed due to the crash of the specimen, ρ is the material density, A is the cross section of the specimen, δ is

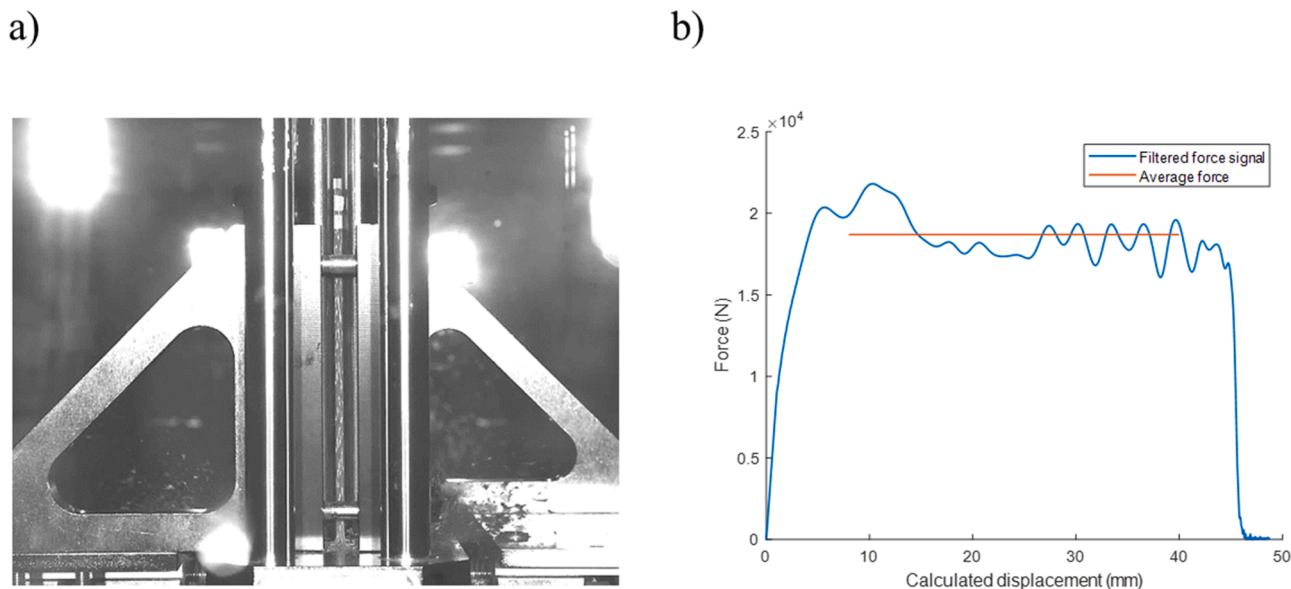

Fig. 4. a) A frame from the high-speed video recorded during the crashworthiness test. b) Force-displacement filtered curve acquired during a test and average crash force calculated in the range between 8 mm and 40 mm.

the displacement of the dropped mass, that corresponds to the crashed length of the specimen, and $F(\delta)$ is the force signal history. The extremes of integration are 8 mm (δ_i), to neglect the influence that the failure trigger has on the first part of the curve, and 40 mm (δ_f) to have the same integration span in all tests.

The objective of this work was to study the effect of the impact velocity and of the friction in the slide of the specimen in contact with the anti-buckling columns on the SEA of the material. A full factorial design of experiment with a center point was implemented as described in Table 1. The same impact energy of 800 J was used in all the tests to avoid possible effects of the impact energy on the SEA and highlight the effect of the impact velocity, according to the literature [33]; the impact mass was changed when changing the impact velocity to keep the same impact energy. The clamping force levels were limited to 8 kN to avoid the overestimation of the SEA that would be caused by excessive friction, while the lower value of clamping force corresponds to the lowest torque that can be exerted with the dynamometric wrench.

2.3. Testing setup for friction tests

In the second phase of the research, the setup was modified to let the specimen slide in vertical direction under the load applied by the dropped mass. The specimen was clamped, leaving a clearance of about 30 mm available for moving downwards before getting in contact with the horizontal lower plate. The impact point of the drop weight testing machine was set accordingly, i.e., moved 30 mm upward with respect to the standard crash tests (Fig. 5a). The clamping force was set to 2 kN in all the tests. The tests were performed in the same Instron 9450 drop tower used for the crash tests, with a different strain gage tup bearing maximum force of 90 kN, which is more suited to record friction forces.

The tests were performed with low values of energy and speed to

Table 1
Experimental plan.

Clamping force (kN)	Velocity (m/s)	Mass (kg)
0.8	4.8	69.4
0.8	9.9	16.4
8	4.8	69.4
8	9.9	16.4
4	7	32.9

have a cleaner force signal. Due to the impact with the specimen, vibrations are excited in the dropped mass and are clearly visible in the acquired force signal. The amplitude of vibrations excited from an impact test typically increases with the impact speed and decreases with the impact mass. In preliminary tests, not reported here, it was noticed that the level of vibrations in friction tests, because of the different testing setup and due to the lower force to be acquired, was too high when using the same impact velocities adopted in the crashworthiness tests (4.8 m/s, 7 m/s, 9.9 m/s). For this reason, the impact velocity was reduced to 1 m/s, which allowed to obtain a signal with an acceptable level of oscillations (noise). Three examples of slide curves, corresponding to three different tribological conditions, are plotted in Fig. 5b.

The impact mass was set to 26 kg, with an impact energy equal to 13 J, which was enough to let the specimen slide for a distance of at least 12 mm. From the average slide force (calculated in the range between 5 mm and 10 mm of displacement, where the force signal becomes stable) it is possible to calculate the friction coefficient as:

$$\mu = \frac{F_s}{2F_c} \quad (3)$$

where F_s is the average sliding force, F_c is the clamping force and the multiplying factor 2 is for considering the clamping force that acts on both the faces of the specimen [31].

Ten repetitions of the test were performed in three different conditions: direct contact between specimen and anti-buckling columns, dry lubricant applied on the columns and dry lubricant applied on both columns and specimen. The lubricant is a CRC dry PTFE lube, that can be applied as a spray on the desired surfaces and becomes solid after some minutes. A layer of lubricant was applied before each test to avoid the possible erosion of the solid lubricant layer in consecutive tests.

3. Results

3.1. Crashworthiness test results

Observing the plots in Fig. 6 that report the SEA (calculated according to Eq. (2)) as a function of the investigated parameters (impact velocity and clamping force), the SEA seems to be not affected by the testing conditions because of the large experimental scatter. The average value of the material SEA, considering all the testing conditions, is 43.6 kJ/kg.

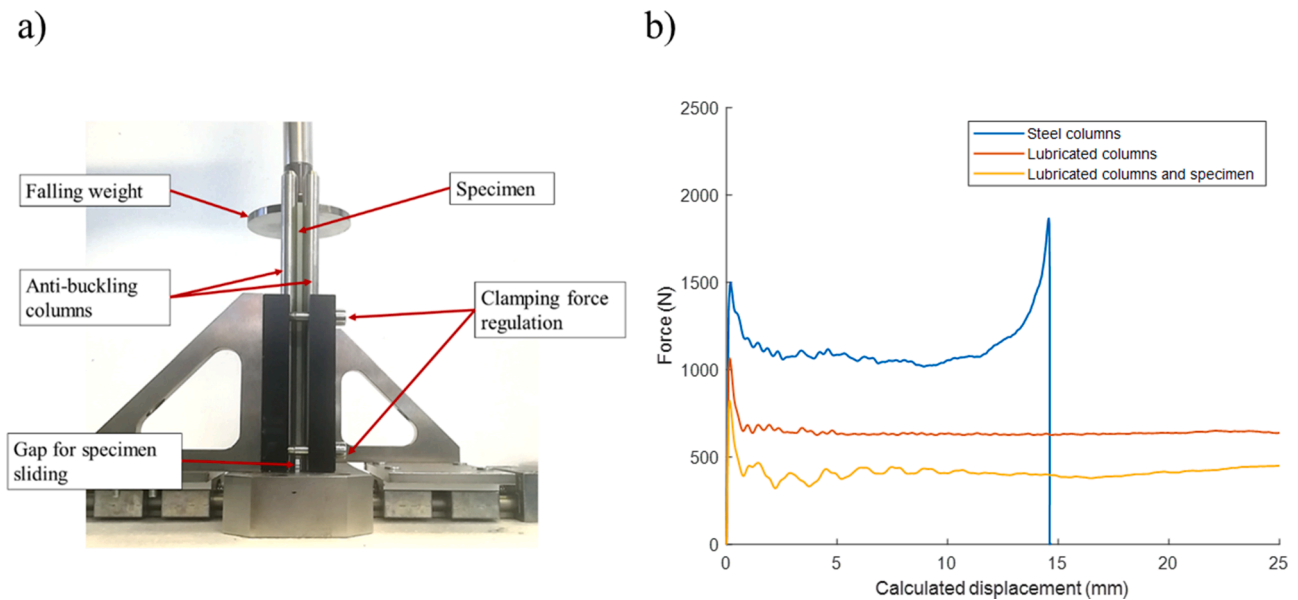

Fig. 5. a) Setup for slide test for friction force measurement. b) Filtered force-displacement curves acquired during slide test for friction force measurement in three different conditions using glass fiber/epoxy flat specimens.

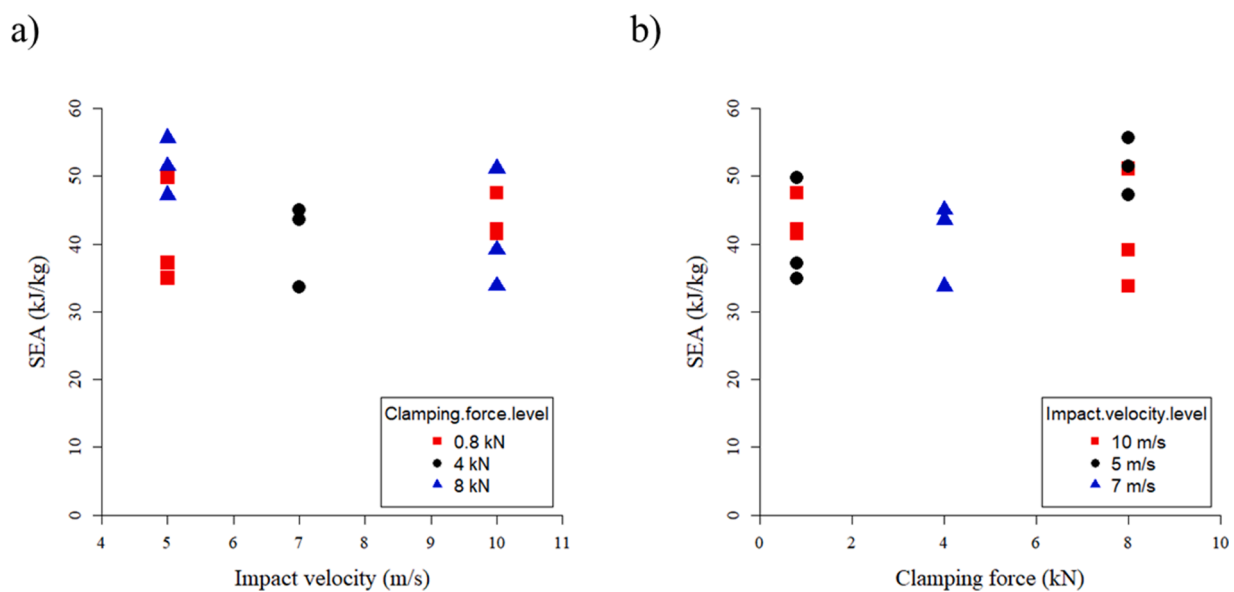

Fig. 6. SEA of the carbon fiber reinforced epoxy specimens measured during crash tests as a function a) of the impact velocity, b) of the clamping force.

The failure mode can be classified from a macroscopic point of view as splaying, that consists of a delamination along the mid plane of the laminate with formation of two fronds (Figs. 7 and 8) and some powders. The observation of the high-speed videos (Fig. 7) allowed to understand the progressive development of failure process. It started with an increase of the force value corresponding to the failure of the trigger, followed by a force plateau. Some oscillations were still visible in the filtered curve and were probably due to the vibrations of the testing equipment and to the natural irregularities of the failure process, that consists of delamination, fragmentation of the material with debris formation, and bending of the layers. The visual appearance of the coupons after the test was not always the same, as shown in Fig. 8a: some specimens showed higher permanent deformation that consists of a wide opening angle of the two fronds, whereas other specimens showed a strong elastic return of the external layers that results in a narrower opening angle of the fronds. In some cases, it is possible to find different

failure modes even on the same specimen, with different level of fragmentation of the matrix and of the fiber fabrics (Fig. 8b). The different behaviors of the material were not correlated to specific testing conditions, but were probably due to the variability of the material properties and induced by the manufacturing process.

The presence of different failure modes could be the responsible of the scatter in the experimental results. To assess a possible influence of the failure modes on the SEA, the ‘fracture angle’ (i.e., the opening angle of the fronds found on the specimen after the test, as depicted in Fig. 9a) has been measured and considered in the analysis. The measurement of the fracture angle is a simplified method to analyze the failure modes if compared with their complexity as depicted in Fig. 8b). However, it represented the easiest way to get a quantitative evaluation of the failure mode. A good correlation between SEA and fracture angle was found, as shown in Fig. 9b. This was probably due to a higher level of energy absorption caused by higher level of deformation angle and

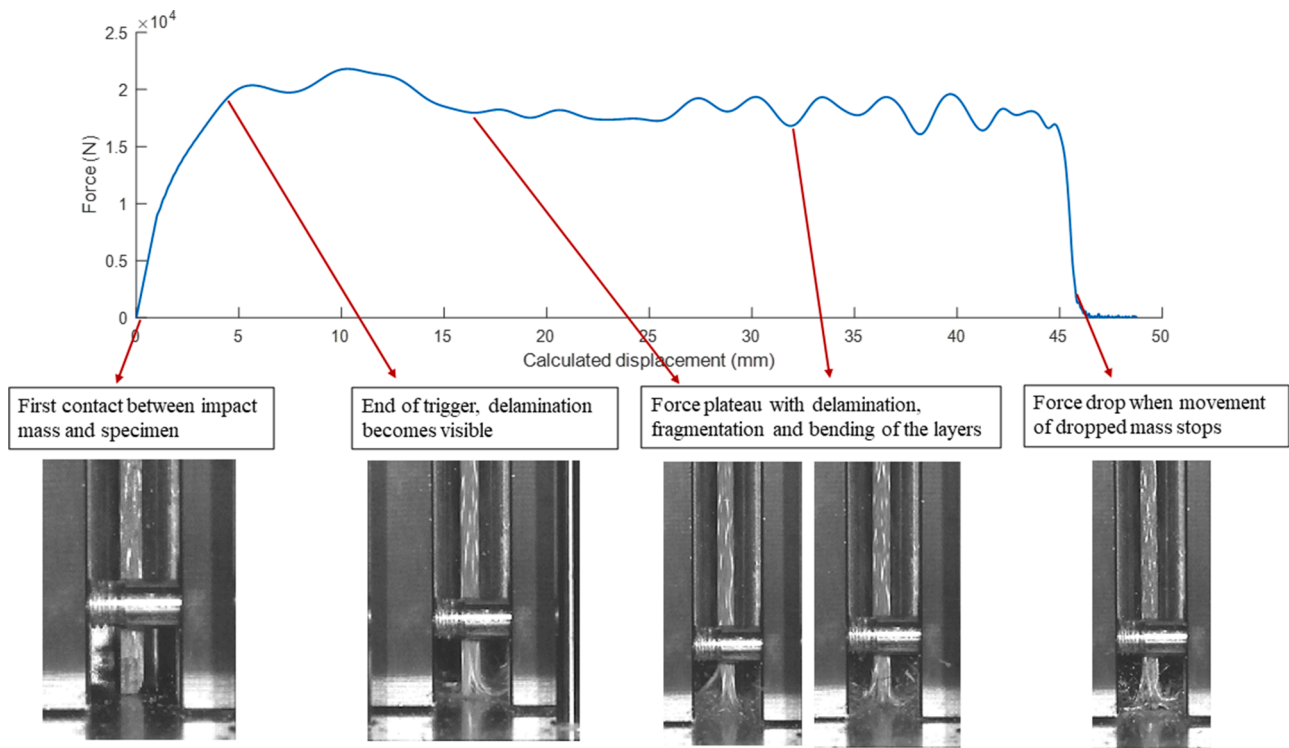

Fig. 7. Phases of the test and details of the failure process.

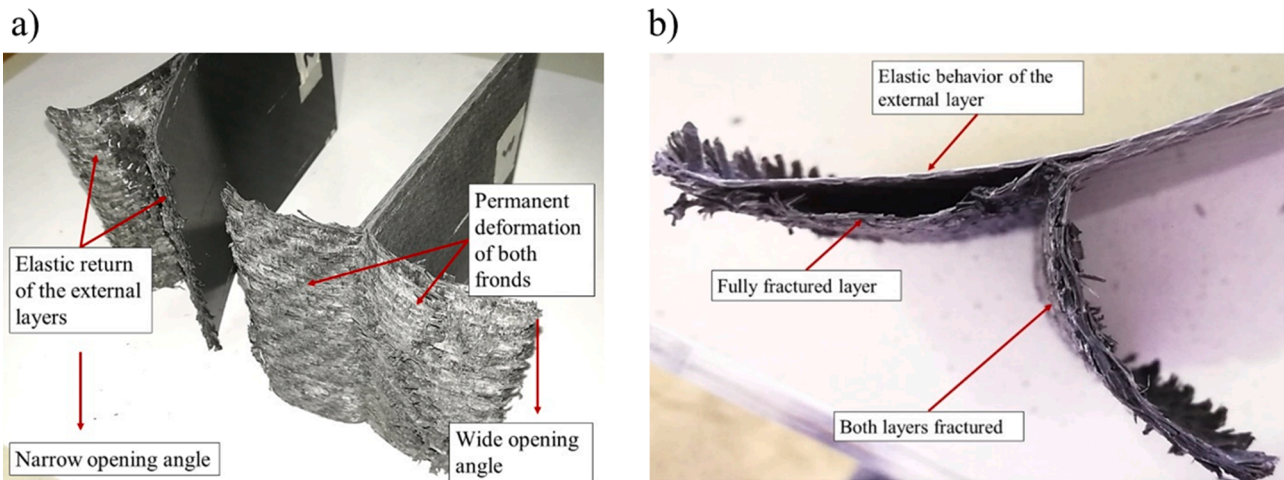

Fig. 8. a) Failure modes after crush tests on carbon fiber specimens. b) Different failure modes found on a single carbon fiber specimen.

fragmentation of the material.

Considering the failure mechanism, the fracture angle can be seen as a new parameter with its own influence on the SEA. This means that the results can be corrected to account for the effect of the failure mode and reveal in a clearer way the effect of the investigated factors (i.e., impact velocity and clamping force). This can be done easily thanks to the linear relation between fracture angle and SEA (Fig 9b). The values of SEA are modified to get an ideal situation where the failure angles are set equal for all the specimens; an average angle of 120° is arbitrarily chosen as reference for this case, but the procedure is valid for any possible choice of angle. This corresponds to the translation of all the experimental points according to the regression line drawn in Fig. 9b, i.e. according to the following equation:

$$SEA_{corr} = SEA + k(120^\circ - \alpha), \tag{4}$$

where $k = 0.131 \text{ kJ}/(\text{kg } ^\circ)$ is the slope of the regression line in Fig. 9b, SEA is the experimental SEA value and α is the fracture angle, in deg, measured as shown in Fig. 9a.

Fig. 10 shows the same experimental results that were plotted in Fig. 6 corrected with Eq. (4). The scatter is evidently reduced. An effect of the impact velocity is not visible in Fig. 10a (same result was found by Duong et al. [34]), but it becomes now clear that the corrected SEA increases with the clamping force, as shown in Fig. 10b. This is clearly an effect of the friction force due to the sliding contact between the specimen and the anti-buckling columns. Since our scope is the evaluation of the material SEA, the friction effect must be controlled carefully to avoid an overestimation of the resulting SEA. This conclusion led to the second part of this study, where the friction force was measured.

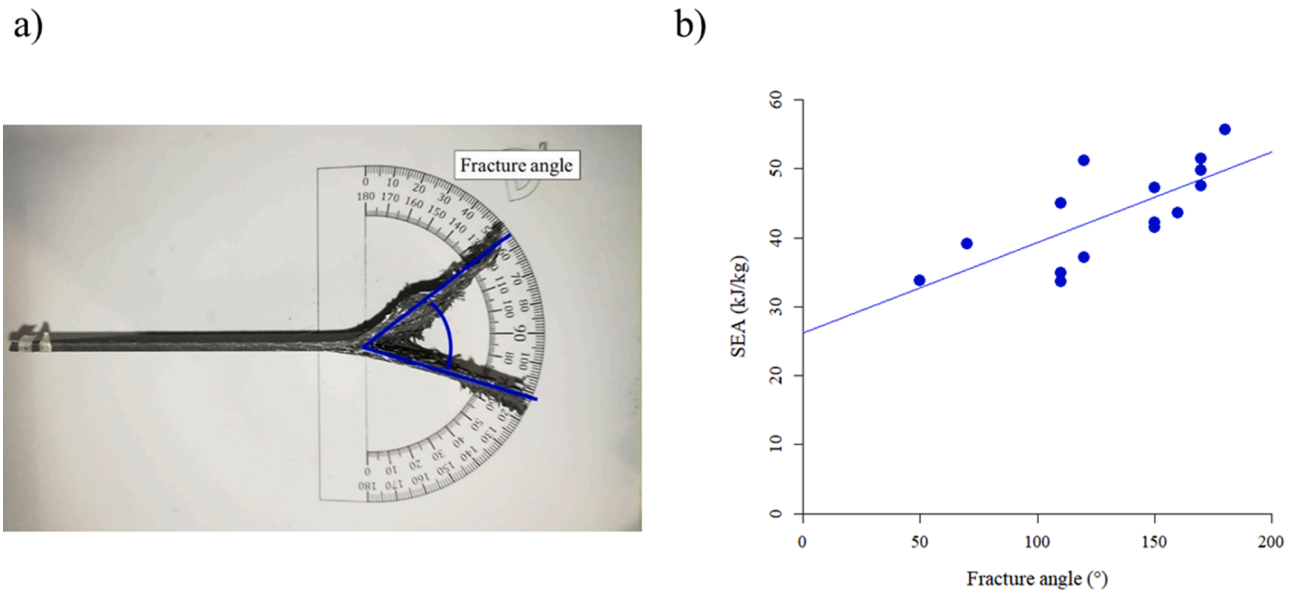

Fig. 9. a) Measurement of the fracture angle of a crashed specimen. b) SEA as a function of the fracture angle.

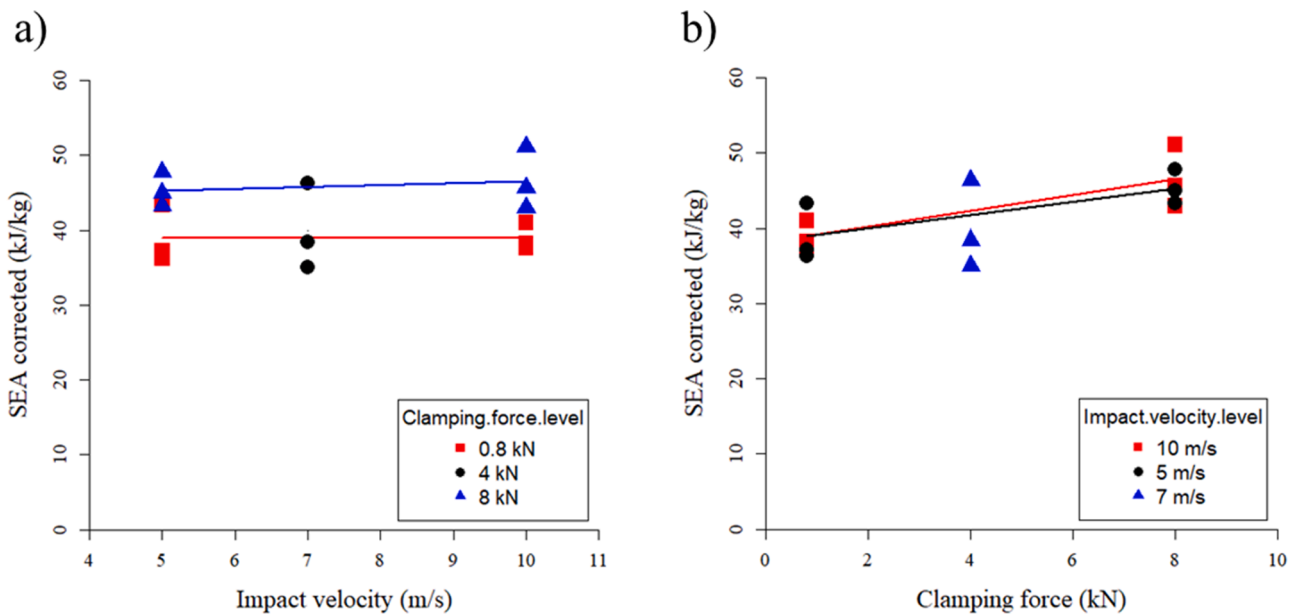

Fig. 10. SEA of the carbon fiber reinforced epoxy specimens after correction as a function a) of the impact velocity. b) of the clamping force.

3.2. Friction test results

In the second phase of this research, the slide tests, conducted according to the testing procedure and with the testing parameters described in Section 2.3, showed a reduction of the friction force when applying a dry lubricant on the anti-buckling columns. In tests carried out with the same clamping force of 8 kN, an average value of the slide force of 956.6 N was found in the tests without lubricant, this value is reduced to 583 N when the PTFE lubricant is applied to the columns and further to 502 N when it is applied to both columns and specimen (Fig. 11).

The Tukey test for multiple comparisons was applied with a confidence level of 95% to the three groups in the software R, showing a statistically significant difference between the non-lubricated condition and the other two. Comparing the two lubricated conditions, the Tukey test does not highlight significant differences. This leads to the

conclusion that the dry lubrication can be useful to reduce the over-estimation of the crash force due to the slide of the specimen in contact with the anti-buckling columns, and both the lubricated solutions are effective (i.e., lubricant on the columns and lubricant on both columns and specimen). The friction coefficients related to the contact between the specimen and the anti-buckling supports were calculated according to Eq. (3) and are reported in Table 2. It is possible to notice a reduction of the friction coefficient of 39% (in the case of lubricated columns) and 48% (in case of lubricated columns and specimen) if compared with the original steel surface of columns.

4. Conclusions

In this research, crashworthiness tests and friction tests in impact conditions were performed, providing the following results:

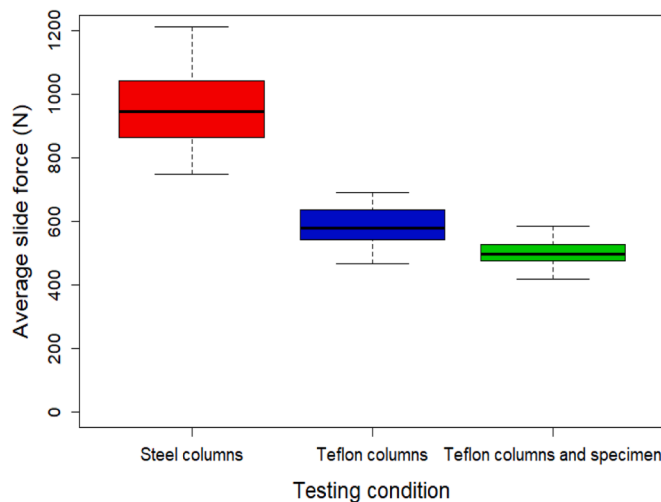

Fig. 11. Box plot representing the average slide forces measured in the three considered testing conditions.

Table 2

Results of the friction tests.

Condition	Average friction force	Standard deviation of average friction force	Friction coefficient
Steel columns	956.6 N	131.3 N	0.060
Lubricated columns	583.0 N	74.0 N	0.036
Lubricated columns and specimen	502.0 N	49.5 N	0.031

- In-plane compression tests were carried out in impact conditions to measure the influence of impact velocity and friction on the SEA of carbon/epoxy flat specimens. An average value of SEA (calculated according to the specified procedure) of 43.6 kJ/kg was obtained and specimens showed a splaying failure mode with some differences: in some specimens a higher level of the final deformation of the fronds was found, and this correlated to a higher value of SEA. This unexpected effect was included in the analysis and the measured SEA was corrected to account for the effect of the failure mode. Corrected results did not show an effect of the impact velocity in the investigated velocity range, while the corrected SEA significantly increased with the clamping force because of the higher energy absorbed by the friction between the supporting columns and the coupon.
- The influence of the clamping force on the SEA led to the second part of this work, where slide tests were carried out to measure the friction force due to the contact between a glass fiber/epoxy specimen and the anti-buckling columns with clamping force of 8 kN. The use of a dry PTFE lubricant applied on the anti-buckling columns surface and on the specimen significantly reduced the friction force. The lowest value of friction force (i.e., about 500 N, as an average, obtained with lubricated columns and specimen) corresponds to about 3% of the average crash force measured during the crash test on carbon/epoxy specimens (i.e., 17 kN). This value can be considered enough low to be not influent on the evaluation of the intrinsic material performance in a crashworthiness test.
- The influence of friction can be further reduced moving to lower values of clamping force; in this study, crash tests were carried out applying a clamping force of 0.8 kN, which is much lower than what was used for the friction force measurements (i.e., 8 kN). The combination of lubrication on both columns and specimen, and clamping force reduced to 0.8 kN corresponds to an overestimation of the SEA of about 0.3%.
- Considering the results of friction tests on glass/epoxy plates with non-lubricated supports, it was possible to estimate the contribution

of the friction force due to specimen clamping on the measured SEA of carbon/epoxy plates. Comparing the measured friction force to the average crash force, the overestimation of the crash force, and consequently of the SEA, was 5.6% with clamping force of 8 kN. Assuming linear dependency between clamping force and friction force, the influence on the SEA reduces to 2.8% for a clamping force of 4 kN, and to 0.6% for a clamping force of 0.8 kN.

Results presented in this paper point out some issues that need to be further assessed in future work:

- The scatter of results and the different failure modes seem to be due to the internal variability of the material properties even in the same material batch; this variability should be investigated more deeply and taken in account when designing composite structures for crashworthiness.
- The friction due to the sliding contact between the specimen and the supporting columns should be controlled and reduced as much as possible since it proved to be influent on the SEA estimation. This goal can be achieved by applying a dry PTFE lubricant on the anti-buckling columns or on the specimen and reducing the clamping force to a minimum.

Funding

This research did not receive any specific grant from funding agencies in the public, commercial, or not-for-profit sectors.

Declaration of Competing Interest

The authors declare that they have no known competing financial interests or personal relationships that could have appeared to influence the work reported in this paper.

Acknowledgements

The authors would like to thank the MS students Riccardo Destefanis and Enio Colonna for their help in performing the friction tests.

References

- [1] DH-J.A. Lukaszewicz, Automotive composite structures for crashworthiness, in: A Elmarakbi (Ed.), *Adv. Compos. Mater. Automot. Appl. Struct. Integr. Crashworthiness*, John Wiley & Sons, Ltd, Chichester, UK, 2013, pp. 99–127, <https://doi.org/10.1002/9781118535288>.
- [2] CMH-17, *Crashworthiness and energy management*. *Compos. Mater. Handb.*, vol. 3, 2012.
- [3] J.J. Carruthers, A.P. Kettle, A.M. Robinson, Energy absorption capability and crashworthiness of composite material structures: a review, *Appl. Mech. Rev.* 51 (1998) 635–649, <https://doi.org/10.1115/1.3100758>.
- [4] P.H. Thornton, *Energy Absorption in Composite Structures*, *J. Compos. Mater.* 13 (1979) 247–262.
- [5] G.L. Farley, R.M. Jones, *Energy-Absorption Capability of Composite Tubes and Beams*, 1989. NASA Technical Memorandum 101634.
- [6] D. Hull, A unified approach to progressive crushing of fibre-reinforced composite tubes, *Compos. Sci. Technol.* 40 (1991) 377–421.
- [7] C. Bisagni, G. Di Pietro, L. Fraschini, D. Terletti, Progressive crushing of fiber-reinforced composite structural components of a Formula One racing car, *Compos. Struct.* 68 (2005) 491–503, <https://doi.org/10.1016/j.compstruct.2004.04.015>.
- [8] S. Heims, F. Strobl, *Crash simulation of an F1 racing car front impact structure*, in: 7th Eur LS-DYNA Conf, 2009, pp. 1–8.
- [9] D. Dalli, L.F. Varandas, G. Catalanotti, S. Foster, B.G. Falzon, Assessing the current modelling approach for predicting the crashworthiness of Formula One composite structures, *Compos. Part B* 201 (2020), 108242, <https://doi.org/10.1016/j.compositesb.2020.108242>.
- [10] J. Obradovic, S. Boria, G. Belingardi, Lightweight design and crash analysis of composite frontal impact energy absorbing structures, *Compos. Struct.* 94 (2012) 423–430, <https://doi.org/10.1016/j.compstruct.2011.08.005>.
- [11] J. Lescheticky, G. Barnes, M. Schrank, System level design simulation to predict passive safety performance for CFRP automotive structures, *SAE Tech. Pap.* 2 (2013), <https://doi.org/10.4271/2013-01-0663>.
- [12] P. Feraboli, F. Deleo, F. Garattoni, Efforts in the standardization of composite materials crashworthiness energy absorption, in: *Am Soc Compos - 22nd Tech Conf Am Soc Compos 2007 - Compos Enabling a New Era Civ Aviat 1*, 2007, pp. 741–759.

- [13] J.A. Lavoie, J. Morton, Design and Application of a Quasistatic Crush Test Fixture for Investigating Scale Effects in Energy Absorbing Composite Plates, 1993. NASA Contractor Report 4526.
- [14] P. Feraboli, Development of a modified flat-plate test specimen and fixture for composite materials crush energy absorption, *J. Compos. Mater.* 43 (2009) 1967–1990, <https://doi.org/10.1177/0021998309343025>.
- [15] V. Aitharaju, H.G. Kia, S. Aashat, V.C. Pulugurtha, Modeling of crush behavior of carbon fiber composites, in: *Proc Am Soc Compos - Thirty-First Tech Conf*, 2016.
- [16] H.A. Israr, S. Rivallant, C. Bouvet, J.J. Barrau, Finite element simulation of $0^\circ/90^\circ$ CFRP laminated plates subjected to crushing using a free-face-crushing concept, *Compos. Part A* 62 (2014) 16–25, <https://doi.org/10.1016/j.compositesa.2014.03.014>.
- [17] S. Cauchi Savona, P.J. Hogg, Effect of fracture toughness properties on the crushing of flat composite plates, *Compos. Sci. Technol.* 66 (2006) 2317–2328, <https://doi.org/10.1016/j.compscitech.2005.11.038>.
- [18] G.C. Jacob, J. Michael Starbuck, S. Simunovic, J.F. Fellers, New test method for determining energy absorption mechanisms in polymer composite plates, *Polym. Compos.* 24 (2003) 706–715, <https://doi.org/10.1002/pc.10064>.
- [19] M. Ueda, S. Anzai, T. Kubo, Progressive crushing of a unidirectional CFRP plate with V-shaped trigger, *Adv. Compos. Mater.* 24 (2015) 85–95, <https://doi.org/10.1080/09243046.2014.882540>.
- [20] C. Reuter, K.H. Sauerland, T. Tröster, Experimental and numerical crushing analysis of circular CFRP tubes under axial impact loading, *Compos. Struct.* 174 (2017) 33–44, <https://doi.org/10.1016/j.compstruct.2017.04.052>.
- [21] J. Lausch, M. Takla, H.G. Schweiger, Crush testing approach for flat-plate fibrous materials, *Compos. Part B* 200 (2020), <https://doi.org/10.1016/j.compositesb.2020.108333>.
- [22] R. Garg, I. Babaei, D.S. Paolino, L. Vigna, L. Cascone, A. Calzolari, et al., Predicting composite component behavior using element level crashworthiness tests, finite element analysis and automated parametric identification, *Materials* 13 (2020) 4501, <https://doi.org/10.3390/ma13204501>.
- [23] I. Babaei, R. Garg, L. Vigna, D.S. Paolino, G. Belingardi, L. Cascone, et al., Newly developed anti-buckling fixture to assess the in-plane crashworthiness of flat composite specimens, *Appl. Sci.* 10 (2020) 7797, <https://doi.org/10.3390/app10217797>.
- [24] L. Vigna, I. Babaei, R. Garg, G. Belingardi, D.S. Paolino, A. Calzolari, et al., An innovative fixture for testing the crashworthiness of composite materials, *Frat Ed Integrità Strutt* 15 (2021) 76–87, <https://doi.org/10.3221/IGF-ESIS.55.06>.
- [25] C.R. Siviour, J.L. Jordan, High strain rate mechanics of polymers: a review, *J. Dyn. Behav. Mater.* 2 (2016) 15–32, <https://doi.org/10.1007/s40870-016-0052-8>.
- [26] M.R. Ayatollahi, B. Bahrami, A.M. Mirzaei, M.Y. Yahya, Effects of support friction on mode I stress intensity factor and fracture toughness in SENB testing, *Theor. Appl. Fract. Mech.* 103 (2019), 102288, <https://doi.org/10.1016/j.tafmec.2019.102288>.
- [27] L. Mencattelli, M. Borotto, J. Cugnoni, R. Lazzeri, J. Botsis, Analysis and evaluation of friction effects on mode II delamination testing, *Compos. Struct.* 190 (2018) 127–136, <https://doi.org/10.1016/j.compstruct.2018.01.085>.
- [28] ASTM G99-17 Standard Test Method for Wear Testing with a Pin-on-Disk Apparatus, 2017, pp. 5–10, <https://doi.org/10.1520/G0099-17>.
- [29] ASTM G133-05 (Reapproved 2016) Standard Test Method for Linearly Reciprocating Ball-on-Flat Sliding Wear, 2016, pp. 1–9, <https://doi.org/10.1520/G0133-05R16.2>.
- [30] ASTM G115-10 (Reapproved 2018) Standard Guide for Measuring and Reporting Friction Coefficients, 2018, <https://doi.org/10.1520/G0115-10R18.2>.
- [31] J. Schön, Coefficient of Friction and Wear of a Carbon Fiber Epoxy Matrix Composite, *Wear* 257 (2004) 395–407, <https://doi.org/10.1016/j.wear.2004.01.008>.
- [32] National Electrical Manufacturers Association, NEMA LI-1-1998 (R2011): *Industrial Laminated Thermosetting Products*, 1998.
- [33] H. Zabala, L. Aretxabaleta, G. Castillo, J. Urien, J. Aurrekoetxea, Impact velocity effect on the delamination of woven carbon – epoxy plates subjected to low-velocity equienergetic impact loads, *Compos. Sci. Technol.* 94 (2014) 48–53, <https://doi.org/10.1016/j.compscitech.2014.01.016>.
- [34] A.V. Duong, S. Rivallant, J.J. Barrau, C. Petiot, B.İ. Malherbe, Influence of speed on the crushing behavior of composite plates, in: *ACCM 7 - 7th Asian-Australasian Conf. Compos. Mater.*, ACCM, Taipei, Taiwan, 2010, pp. 678–681, vol. 1n.d.