

Application of T6 Heat Treatment on the AlSi9Cu3 (Fe) Casting Alloy and the Effect of Copper Content

Original

Application of T6 Heat Treatment on the AlSi9Cu3 (Fe) Casting Alloy and the Effect of Copper Content / Doglione, Roberto; Di Geronimo, Paolo; Morano, Angelo. - In: AMERICAN JOURNAL OF APPLIED SCIENCES. - ELETTRONICO. - 12:1(2021), pp. 64-70.

Availability:

This version is available at: 11583/2938433 since: 2021-11-17T15:00:27Z

Publisher:

American Journal of Applied Sciences

Published

DOI:

Terms of use:

This article is made available under terms and conditions as specified in the corresponding bibliographic description in the repository

Publisher copyright

(Article begins on next page)

Application of T6 Heat Treatment on the AlSi9Cu3 (Fe) Casting Alloy and the Effect of Copper Content

R. Doglione^a, P. Di Geronimo^b, A. Morano^b

^a corresponding author, INSTM, Via Giuseppe Giusti 9 - 50121 Firenze (FI), Italy

^b Politecnico di Torino, corso Duca degli Abruzzi 24, 10129 Torino, Italy

Abstract -- *AlSi9Cu3 (Fe) foundry alloy is commonly used to produce components by High Pressure Die Casting (HPDC) for automotive and electrical industries. Mostly for cost reasons, the Cu content is held at the minimum of the compositional range foreseen by the standards. The strength of the metal is then quite low and therefore the components are used only in low or non-stressed applications. The experimental results of the present paper show that in the as cast temper, the percentage of Cu has little effect on strength. It is suggested that alternative alloys for HPDC with lower or no Cu content be adopted for non-stressed components. In the last 15 years, it has been demonstrated that Al-Si-Cu alloys for HPDC may successfully heat-treated by unconventional T6 without causing surface blistering or dimensional instability. Despite the new opportunities, there have been few industrial applications. Instead, the present authors believe possible new technological outcomes for unconventional T6, and have therefore experimented with the AlSi9Cu3 (Fe) alloy with different Cu contents. By using SEM-EDX microanalysis to get Cu composition maps in the alloy microstructure, a T6 heat treatment with lower solubilization temperature and shorter soaking time to avoiding blistering has been identified. Tensile test confirmed the effectiveness of unconventional T6 and showed a strong increase in the elastic limit of the material. The results also show that the best effect is obtained by increasing the Cu content as much as possible. It is therefore possible to produce components for highly stressed structural applications in T6 treated AlSi9Cu3 (Fe) alloy.*

Keywords -- AlSi9Cu3 (Fe) alloy, HPDC, blistering, Cu content, unconventional T6, SEM-EDX composition maps, elastic limit, stressed components.

INTRODUCTION

In-ground vehicles, the competition continues for the increasing use of lightweight Al- or Mg-based alloys to lighten vehicle structures. However, for Al alloys, the landscape of developing new alloys or proposing new applications seems somewhat close to saturation. Therefore, attempts are being made to improve the in-service behaviour of well-known, low-cost alloys, by refining the compositional control of materials or by introducing new heat treatments. Perhaps the most typical example is the AlSi9Cu3(Fe) foundry Al-Si-Cu alloy, alias EN AC-46000 [1] or ASTM A380 [2]. It is a secondary alloy based on recycled material, and therefore of low cost, but very widespread in structural applications in land vehicles. It is suited to large-scale production because it is used to produce components using High Pressure Die Casting (HPDC) technology. A cast, AlSi9Cu3(Fe) alloy has moderate mechanical strength and very limited ductility. The moderate strength is due to the presence of Si crystals and Cu-containing intermetallic compounds (mainly Al₂Cu) that precipitate during solidification. The size of such compounds is of the order of 1-10 μm, thus too large to give strong precipitation strengthening effect. On the other hand, a considerable porosity is introduced by High Pressure Die Casting technology, because of air trapped by the metal during the casting at high liquid velocity [3]. This contributes greatly to lowering the strength of the alloy and especially to depressing its ductility.

In as cast condition (F temper), the alloy has a low elastic limit, ductility, and fatigue resistance. Corrosion resistance is also limited and is worsened by increasing Cu contents. Therefore, the applications mainly concern the automotive and electrical industries, where AlSi9Cu3(Fe) alloy is used for motor frames and housings (gearboxes, inlet manifolds, covers, electric motor and alternator housing, pump and compressor bodies, etc.), where mechanical stresses are moderate and fatigue is almost absent. Stressed applications where fatigue is also present, such as motor and alternator supports, wheel suspension arms and wheels would be precluded or doubtful.

AlSi9Cu3(Fe) alloy contains [1] appreciable amounts of copper (2-4%), so it could be effectively precipitation hardened by T6 heat treatment. This has been known for a long time, and there have been many attempts to obtain appreciable results. Few were truly convincing outcomes while, in most cases, the T6-treated components were unusable because of the problem of blistering. During T6, the solubilization phase at high temperature is the critical one, because the air bubbles trapped during HPDC expand to such an extent that they

emerge on the surface or irreparably distort the components [4, 5]. The historical conclusion has been that AlSi9Cu3(Fe) alloy is not T6 treatable in most cases, except to produce castings with little or no entrained air by HPDC casting, by adopting vacuum (low pressure) die casting. The complication or cost of the latter technique has hindered its widespread use, so the industry has been left with the belief that AlSi9Cu3(Fe) alloy is applied primarily in F temper, with mechanical properties no more than moderate.

However, about 15 years ago a strong impulse to reconsider the issue came from Australia [6-8]. Lumley et al. demonstrated that shorter solution heatings (tens of minutes instead of 10-15 hours) and lower temperatures (460-480°C instead of 520°C) allowed to limit the blistering phenomenon and therefore relaunch the application of T6 treatment, being able to achieve higher mechanical properties and distortion-free parts. These very interesting results have generated studies in different countries of the world [9-12], which have substantially confirmed the applicability of special T6 heat treatment on AlSi9Cu3(Fe) alloy components produced with HPDC.

Not even with these encouraging results has it been possible to break through the wall of prejudice, so that there are very few cases of application of T6 treatment. In reality, behind the problem, there are also economic issues. Indeed, Cu is an expensive element. Moreover, the compositional range of Cu in the alloy [1] is unreasonably wide, ranging from 2 to 4% by mass. Consequently, designers prescribe the use of AlSi9Cu3(Fe) alloy, but deliveries almost invariably occur with Cu=2%. Furthermore, increasing Cu content also increases the susceptibility of the metal to corrosion, which can be more easily attacked if the component works in very humid conditions or polluted environments (presence of chlorides, sulfates, and other aggressive ions) [13].

Instead, the authors of this paper believe that there are ample application opportunities for T6-treated AlSi9Cu3(Fe) alloy. To show this, they decided to apply an unconventional T6 treatment on two AlSi9Cu3(Fe) alloy castings with two different Cu contents. A comparison of the experimental results of the present work with those already published in the literature is then carried out. From the comparison, an overall picture is thus composed where the critical factors that hinder the application of T6 to AlSi9Cu3(Fe) alloy emerge.

MATERIALS AND METHODS

Two AlSi9Cu3(Fe) alloy supplies with two different values of the Cu percentage, i.e., 2.4 and 3.2%, both included in the chemical composition limit [1], were chosen. Table 1 shows the compositions of the two supplies, checked after casting by a chemical analysis performed by spark emission spectrometry. Each of the supplies was subsequently cast by HPDC. Tensile test castings were produced, Figure 1. After the casting risers and sprues were removed, the castings were used without further mechanical processing to perform tensile testing.

Tensile tests were performed on the as-cast specimens and T6 heat-treated specimens. Tensile tests were performed using a 100 kN MTS servohydraulic universal testing machine. The tests were conducted in stroke control under quasistatic conditions, i.e., near a strain rate of $5 \cdot 10^{-4}$ s⁻¹. Elastic limit, tensile strength, and elongation at break were determined.

The T6 heat treatment was carried out by solubilization at 480°C for very short times, i.e. 10, 20, and 50 minutes. Note that the conventional T6 solution-treatment schedule for the alloy is 16 hours at 540°C. In our case, the application of the conventional solution treatment schedule would have resulted in blistering due to the presence of porosity from trapped air (especially in the heads of the samples in Figure 1), which would have caused the heat treatment to fail. The lower temperature and short times adopted here allowed the blistering phenomenon to be avoided. After solubilization, the samples were quenched in water at 25°C. The samples then rested 24 h at room temperature and finally underwent a 2 h aging at 180°C to reach peak hardness.

Cu gives the main effect of precipitation strengthening. To have the greatest possible effect, it is necessary that all micrometric Cu-containing precipitates generated during solidification pass into the solid solution at 480°C. At the same time, it is desired that solubilization be as short as possible to avoid the blistering phenomenon. The dissolution kinetics of Cu was controlled by carrying out composition maps by SEM EDX. We used the SEM Zeiss EVO 15 to perform the microanalysis. The F and T6 samples, for different solution times, were subjected to metallographic polishing without chemical etching, and subsequently introduced into the SEM chamber for the microanalysis. For each solubilization condition, 7 composition maps were acquired in different zones of each sample. The composition maps allowed us to evaluate the minimum time of solubilization at the prefixed temperature of 480°C. A suitable solubilization time was chosen when all Cu-containing compounds (mainly Al2Cu) dissolved and Cu became available in solid solution for the subsequent precipitation strengthening during aging.

Table 1: chemical composition (mass pct.) of the two castings

Si	Fe	Cu	Mn	Mg	Cr	Ni	Zn	Al
8.93	0.87	2.39	0.22	0.15	0.08	0.05	0.86	bal.
7.99	0.87	3.18	0.23	0.15	0.07	0.05	0.82	bal.

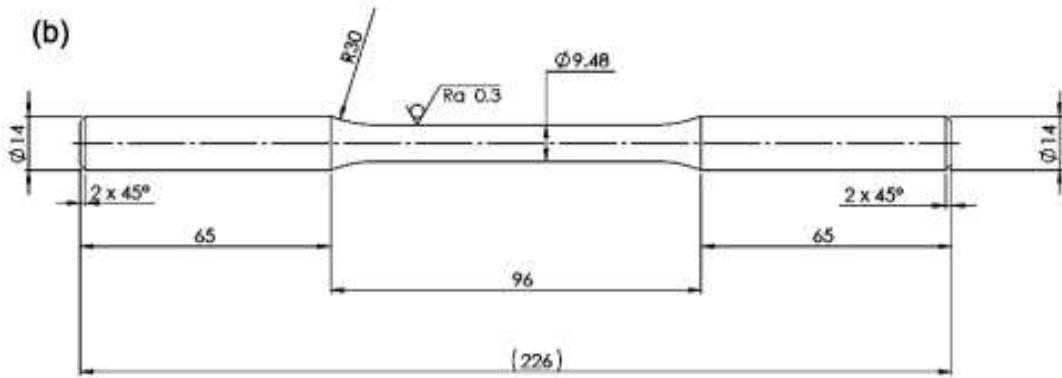

Figure 1: picture of the casting (a) and drawing of the tensile test samples (b) cast by HPDC.

RESULTS

The SEM-EDX composition maps, as shown in Figures 2 and 3 for the casting containing Cu=2.4%, allowed us to choose a solubilization time that would allow us to bring as much Cu as possible into solid solution, without blistering phenomena. It was found that the solubilization of 10 minutes at 480°C is not sufficient to bring all Cu into a solid solution. On the contrary, by comparing Figure 2 and 3, it can be inferred that after 20 minutes the solution is almost complete. After 50 minutes at 480°C, no residual Cu-containing precipitate could be found in any of the maps. Given the risks associated with blistering, a solubilization time of 20 min at 480°C was chosen as the best compromise between precipitation hardening and trapped air porosity migration. As a result, tensile tests were performed on F and T6 with 20-minute solubilization at 480°C samples.

The engineering stress-strain curves for both castings (Cu=2.4 and 3.2%) and both tempers (F and T6 in the above conditions) are shown in Figure 4. The Cu percentage difference between the casting is moderate, only 0.8%, but the effect may be important. The result of increasing Cu content is quite modest for the as-cast samples. On the contrary, the T6 heat treatment provides a noticeable increase in strength, as expected, though with some sacrifice in ductility. In Table 2 the elastic limit, strength, and elongation are summarized to better carry out the comparison and discussion. The most important mechanical characteristic for structural application is the elastic limit. The variation in Cu content has a modest effect in the as-cast samples, only 7.5% on average. On the other hand, the elastic limit increases by 81% (for Cu=2.4%) and 103% (for Cu=3.2%) comparing F and T6 tempers. These data are shown in Table 3.

A similar trend, though mitigated, is observed for the tensile strength. Moreover, the results are much more scattered. This is not surprising, because AlSi9Cu3(Fe) alloy is known to have limited ductility. The increase in strength obtained by the T6 heat treatment has led to a loss in elongation, particularly pronounced for the higher strength (T6 for Cu=3.2%). Since Al-Si-Cu do not show generally necking during tension test (here, also, see Figure 4), the stress-strain curve is simply monotonic; in this case, the loss in ductility reduces the increasing in tensile strength.

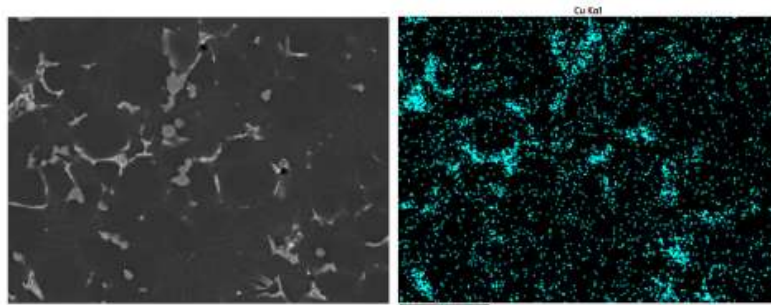

Figure 2: microstructure (left) and Cu composition map (right) of the same zone of a sample as cast (F temper) containing Cu=2.4%. On the left, the secondary phases (light gray) generated during the solidification process are shown. They contain Al, Si, Cu, Fe. On the right, light blue depicts the distribution of Cu in the microstructure. Single light blue points indicate Cu in solid solution, whereas light blue cluster indicate Cu containing precipitates.

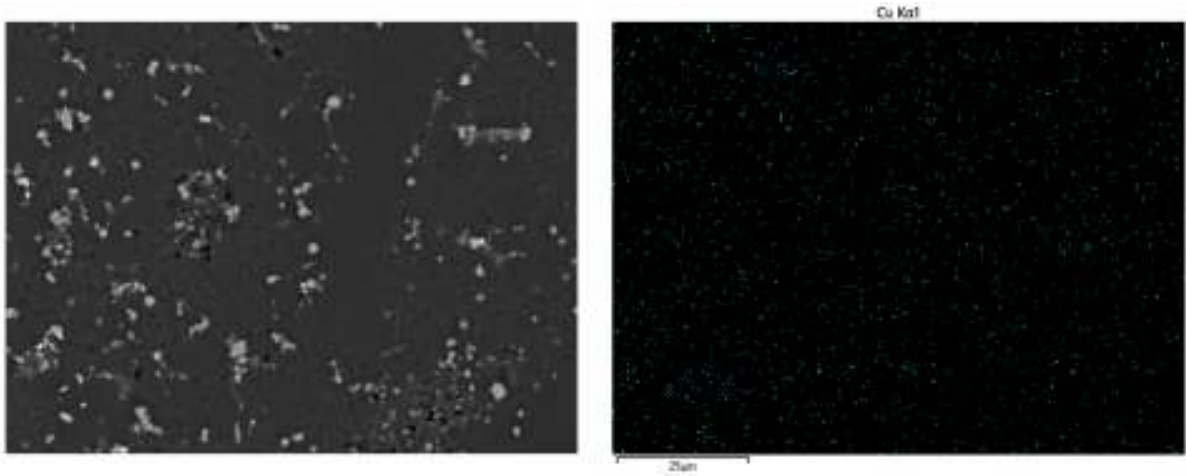

Figure 3: microstructure (left) and Cu composition map (right) of the same zone of a sample T6 treated (solution 480°C for 20 minutes, water quenching and ageing at 180°C for 2 h) containing Cu=2.4%. On the left, the secondary phases (light gray) undissolved during the solution treatment are shown. They contain Al, Si, Fe. On the right, light blue depicts the distribution of Cu in the microstructure. Single light blue points indicate only the presence of Cu in solid solution, without any retained Cu containing precipitates.

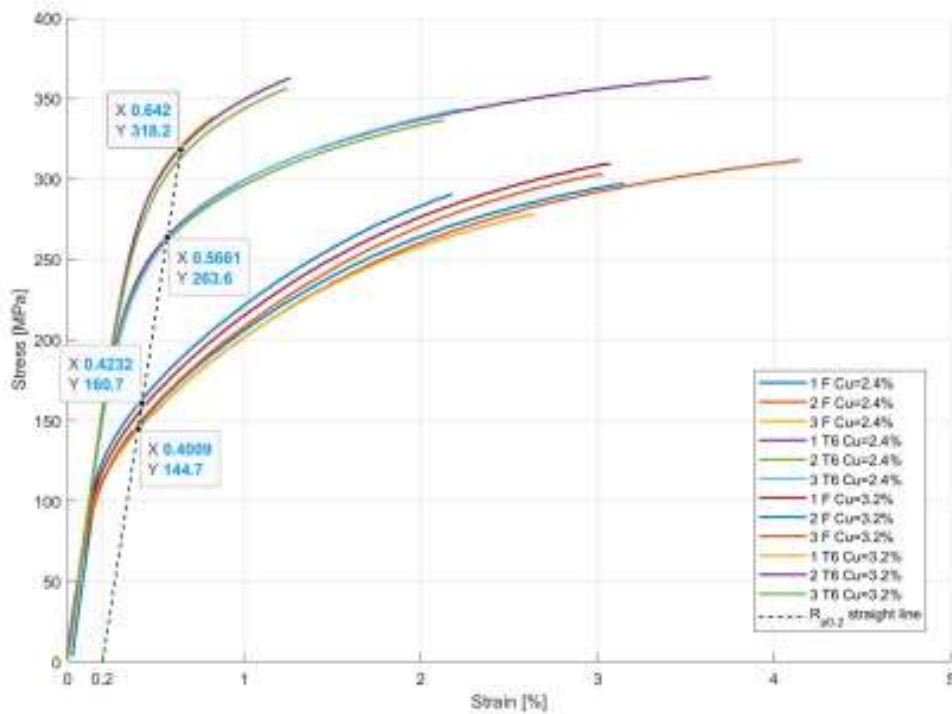

Figure 4: stress-strain curves obtained by tension tests. The dotted $R_{p0.2}$ line indicated the position of the elastic limit in each curve. The letter X indicates the pct. strain at the elastic limit, the letter Y indicate the stress at the elastic limit, i.e. the conventional yield point.

Table 2: summary of the results of the tension test. For each temper, the data is the average of the results of 3 samples (see also the curves in Figure 4).

Temper/casting	$R_{p0.2}$ [MPa]	R [MPa]	A%
F/Cu=2.4%	145	295	2.9
T6/Cu=2.4%	263	347	2.2
F/Cu=3.2%	156	301	2.3
T6/Cu=3.2%	317	353	0.6

Table 3: effect of the Cu content on the increase of the elastic limit for the two castings

Cu % (mass pct)	Percentage increase of elastic limit between the two F castings	Percentage increase of elastic limit between F and T6
	2.4	7.5
3.2	103	

DISCUSSION

The above results have clearly shown that, for AlSi9Cu3(Fe) alloy applied in HPDC, an increase in Cu content is of little use for components utilized as cast. In Figure 5 a summary of the present results and those reported in the literature [7, 8, 12, 14] for different Cu percentages are shown: an increase in Cu content involves only limited growth of the elastic limit (see also [15] for alloying elements range larger than that prescribed by the standards [1, 2]). Therefore the F temper is suitable to no or little stressed components. In this case, the usual choice is to select an AlSi9Cu3(Fe) alloy with Cu content close to the lower limit, i.e. 2%. Anyway, Cu is expensive, worsens significantly the corrosion resistance of Al-Si alloys, and, finally, induces hot tearing. A possible alternative for HPDC would be the use of AlSi11Cu2(Fe) alloy: at the same mechanical characteristics [1], the higher Si content improves castability and contrasts hot tearing. Another alternative is to choose a binary Al-Si alloy such as the AlSi12(Fe), always at the same mechanical characteristics [1].

The application of T6 heat treatment on AlSi9Cu3(Fe) is quite attractive for stressed structural components, provided that HPDC does not introduce too relevant entrapped air percentage and during solubilization blistering does not occur. To avoid blistering, in the present paper and literature, possible solubilization time-temperature combinations are proposed. The present results confirm and emphasize that lower than usual temperature and shorter solubilization time is a practicable way.

About the T6 heat treatment, an important issue is the Cu content. In Figure 6 the results reported in the literature [6, 7, 9, 12, 16] about elastic limit are summarized, together with the present results. The scatter is noticeable, but an important increasing trend is evident. The scatter in general may be due to the following several factors: different casting techniques [17, 18], different time-temperature combinations during solubilization [17], different time-temperature combinations during ageing [17], and finally, a certain variability in Mg content [19, 20], it also able to produce precipitation hardening. From Figure 6 it may be argued that T6 is a good opportunity for AlSi9Cu3(Fe) alloy used in HPDC productions with low or moderate porosity, provide that blistering may be avoided during heat treatment. However, for the application of the alloy in stressed structural components, an important conclusion of the present experimental results and of the previous discussion is that Cu content should be in the range of 3-4% to take full advantage of the precipitation hardening provided by Cu.

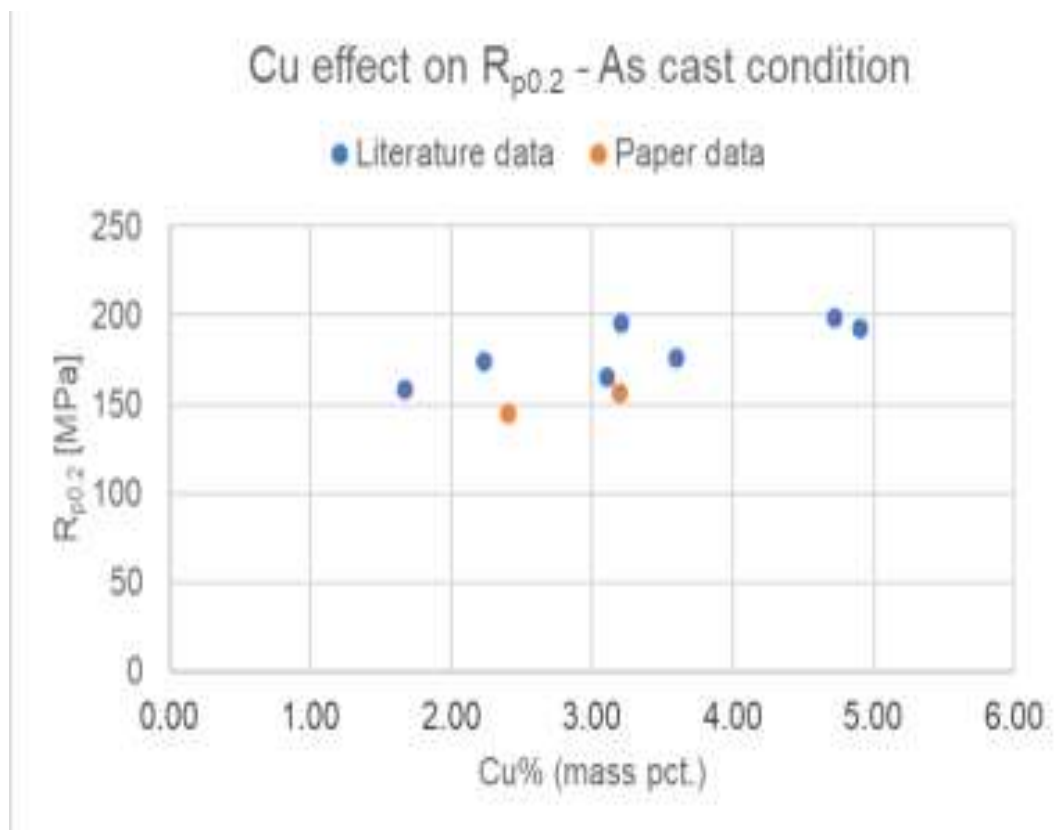

Figure 5: summary of the elastic limit results reported in the literature (blue dot) [7, 8, 12, 14] and obtained in the present tension tests (orange dot) for as-cast AlSi9Cu3(Fe) alloy.

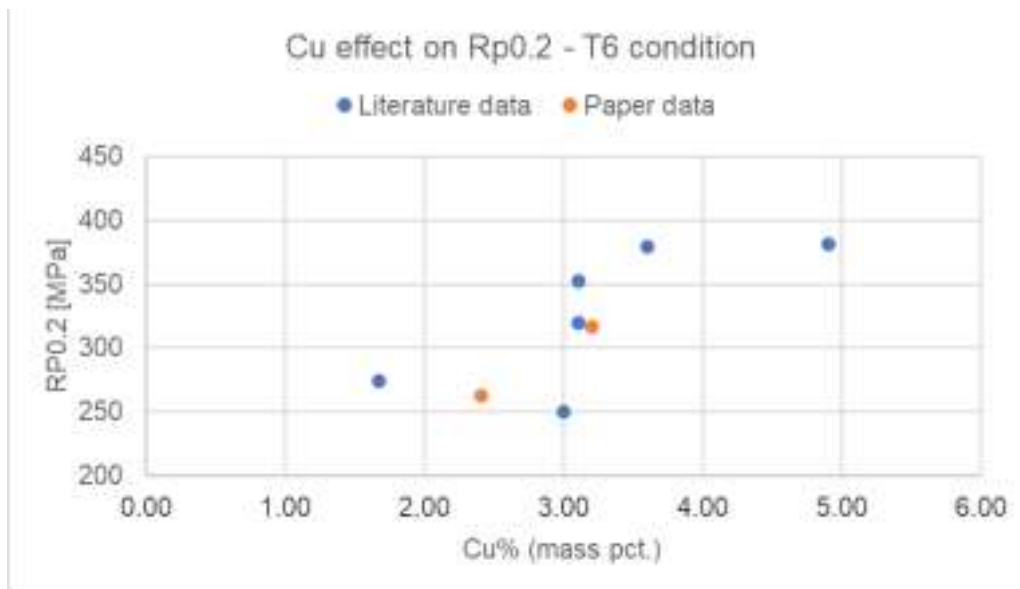

Figure 6: summary of the elastic limit results reported in the literature (blue dot) [6, 7, 9, 12, 16] and obtained in the present tension tests (orange dot) for AlSi9Cu3(Fe) alloy subjected to several T6 heat treatments.

CONCLUSIONS

The comparison between 2 castings of AlSi9Cu3 (Fe) alloy with increasing Cu content, showed very similar strength in the as-cast condition. The same strength level may be obtained also with a similar alloy, but with lower Cu content or simply with binary Al-Si alloys. It may be concluded that the usual application of AlSi9Cu3 (Fe) alloy is wasted in non-stressed components for automotive and electrical industries. On the other hand, considering components produced by HPDC, trapped air embedded during the process makes it delicate to apply the T6 treatment to achieve important increases in mechanical strength, especially the elastic limit, because of the occurrence of blistering of the components. Cu content maps of the microstructure, here obtained by SEM-EDX microanalysis, allowed to perform a T6 heat treatment with lower solubilization temperature and shorter soaking time, thus avoiding blistering. In T6 treated samples, the tension test indicated that increasing Cu content is crucial to obtain high strength. In this way, the possibility of application of AlSi9Cu3(Fe) in structural stressed components is opened.

ACKNOWLEDGEMENT

The authors gratefully acknowledge Prof. Franco Bonollo of the University of Padova (Padova, Italy) and Dr. Ruggero Zambelli of Raffmetal S.p.a. Society (Casto, Italy) for his invaluable help to find the AlSi9Cu3(Fe) alloy of the sought chemical composition.

REFERENCES

- [1] CEN-CENELEC European Standard EN 1706, "Aluminium and aluminium alloys — Castings — Chemical composition and mechanical properties", 2020
- [2] ASTM B85/M - 18, "Standard Specification for Aluminium Alloy Die Casting", 2018
- [3] "Die Casting Tooling" in ASM Handbook Volume 15: Casting, ASM International, p. 739, 2008
- [4] I. Polmear, "Cast Aluminium Alloys" in Light Alloys, From Traditional Alloys to Nanocrystals, fourth edition, Butterworth-Heinemann, pp. 209-210, 2006
- [5] Zihao Yuan, Zhipeng Guo, S.M. Xiong, "Skin layer of A380 aluminium alloy die castings and its blistering during solution treatment", Journal of Materials Science & Technology, vol. 35, pp. 1906-1916, 2019
- [6] R.N. Lumley, R.G. O'Donnell, D.R. Gunasegaram, M. Givord, "Heat Treatment of High Pressure Die Castings", Metallurgical and Materials Transactions A, vol. 38A, pp. 2564- 2574, 2007
- [7] R.N. Lumley, R.G. O'Donnell, D.R. Gunasegaram, T. Kittel-Sherri, M. Gershenzon, A.C Yob, I. Polmear, "The role of alloy composition in the heat treatment of aluminium high pressure die casting", Metallurgical Science and Technology, vol. 26-2, 2008
- [8] R.N. Lumley, I.J. Polmear, P. R. Curtis, "Rapid Heat Treatment of Aluminium High Pressure Diecasting", Metallurgical and Materials Transactions A, vol. 40A, pp. 1716-1726, 2009
- [9] E.Sjölander, S. Seifeddine, "Artificial ageing of Al-Si-Cu-Mg casting alloys", Materials Science and Engineering, vol. A 528, pp. 7402-7409, 2011

- [10] J. Pezda, "Optimization of T6 heat treatment process of AlSi9Cu3(Fe) alloy in aspect of improvement of its mechanical properties", *Metalurgia International*, vol. XVIII no. 10, 2013
- [11] Y. Han, A. M. Samuel, H. W. Doty, S. Valtierra, F. H. Samuel, "Optimizing the tensile properties of Al-Si-Cu-Mg 319-type alloys: Role of solution heat treatment", *Materials and Design*, vol. 58, pp. 426-438, 2014
- [12] Silvia Cecchel, Andrea Panvini, Giovanna Cornacchia, "Low Solution Temperature Heat Treatment of AlSi9Cu3(Fe) High-Pressure Die-Casting Actual Automotive Components", *Journal of Materials Engineering and Performance*, vol. 27(8), pp. 3791- 3802, 2018
- [13] I. Polmear, *Light Alloys, From Traditional Alloys to Nanocrystals*, fourth edition, Butterworth-Heinemann, pp.73, 224, 2006
- [14] Maja Vončina, Nataša Močnik, Aleš Nagode, Antun Stoić, Milan Bizjak, "Dependence of mechanical properties on Cu content in AlSi9Cu3(Fe) alloy", vol. Tehnički vjesnik 24, Suppl. 1, pp. 229-231, 2017
- [15] F. Sanna, A. Fabrizi, S. Ferraro, G. Timelli, P. Ferro, F. Bonollo, "Multiscale characterisation of AlSi9Cu3(Fe) die casting alloys after Cu, Mg, Zn, and Sr addition", *La Metallurgia Italiana*, vol. 4, pp. 13-24, 2013
- [16] I.Aguilera Luna, H.Mancha Molinar, M.J.Castro Román, J.C.Escobedo Bocado, M.Herrera Trejo, "Improvement of the tensile properties of an Al-Si-Cu-Mg aluminium industrial alloy by using multi stage solution heat treatments", *Materials Science and Engineering*, vol. A 561, pp. 1-6, 2013
- [17] L. Hortalova, E. Tillova, M. Chalupova, "The Structure Analysis of Secondary (Recycled) AlSi9Cu3 Cast Alloy with and without Heat Treatment", *Engng. Trans*, Vol. 61, , no. 3, pp. 197-218, 2013
- [18] Ridvan Gecu, Serhat Acar, Alptekin Kisasoz, Kerem Altug Guler, Ahmet Karaaslan, "Influence of T6 heat treatment on A356 and A380 aluminium alloys manufactured by thixoforging combined with low superheat casting", *Trans. Nonferrous Met. Soc. China*, vol 28, pp. 385-392, 2018
- [19] Jacek Pezda, "Heat treatment of the EN AC- AlSi9Cu3(Fe) alloy", *ARCHIVES of FOUNDRY ENGINEERING*, vol. 10, pp. 99-102, 2010
- [20] Yan Zheng, Wenlong Xiao, Sujing Ge, Weitao Zhao, Shuji Hanada, Chaoli Ma, "Effects of Cu content and Cu/Mg ratio on the microstructure and mechanical properties of Al-Si-Cu-Mg alloys", *Journal of Alloys and Compounds*, vol. 649, pp. 291-296, 2015.