

A Novel Satellite Architecture for the Next Generation of Earth Observation Satellites Supporting Rapid Alerts

*Original*

A Novel Satellite Architecture for the Next Generation of Earth Observation Satellites Supporting Rapid Alerts / Kerr, M., Tonetti, S., Cornara, S., Bravo, J.I., Hinz, R., Latorre, A., Membibre, F., Ramos, A., Solimini, C., Wiehle, S., Breit, H., Günzel, D., Mandapati, S., Tings, B., Balss, U., Koudelka, O., Teschl, F., Magli, E., Bianchi, T., Migliorati, A., et al.. - ELETTRONICO. - (2021), pp. 1-7. (Small Satellite Conference 2021 Virtual event August 7-12, 2021).

*Availability:*

This version is available at: 11583/2938202 since: 2021-11-16T16:59:17Z

*Publisher:*

Utah State University

*Published*

DOI:

*Terms of use:*

This article is made available under terms and conditions as specified in the corresponding bibliographic description in the repository

*Publisher copyright*

(Article begins on next page)

## A Novel Satellite Architecture for the Next Generation of Earth Observation Satellites Supporting Rapid Alerts

M. Kerr, S. Tonetti, S. Cornara, J. I. Bravo, R. Hinz, A. Latorre, F. Membibre, A. Ramos, A. Moron, C. Solimini  
DEIMOS Space S.L.U.  
Ronda de Poniente 19, Tres Cantos (Madrid), 28005, Spain; +34 918 063 450  
[murray.kerr@deimos-space.com](mailto:murray.kerr@deimos-space.com)

S. Wiehle, H. Breit, D. Günzel, S. Mandapati, B. Tings, U. Bals  
Deutsches Zentrum für Luft- und Raumfahrt e.V.  
Bremen, Germany  
[stefan.wiehle@dlr.de](mailto:stefan.wiehle@dlr.de)

O. Koudelka, F. Teschl,  
Technische Universität Graz  
Graz, Austria  
[koudelka@tugraz.at](mailto:koudelka@tugraz.at)

E. Magli, T. Bianchi, A. Migliorati, P. Motto Ros, M. Caon, M. Martina  
Politecnico di Torino  
Turin, Italy  
[enrico.magli@polito.it](mailto:enrico.magli@polito.it)

R. Freddi, F. Milani, G. Curci  
OHB Italia Spa  
Milan, Italy  
[riccardo.freddi@ohb-italia.it](mailto:riccardo.freddi@ohb-italia.it)

S. Fraile  
Deimos Imaging S.L.U.  
Tres Cantos, Madrid, Spain  
[silvia.fraile@deimos-imaging.com](mailto:silvia.fraile@deimos-imaging.com)

C. Marcos  
Agencia Estatal de Meteorología  
Madrid, Spain  
[cmarcosm@aemet.es](mailto:cmarcosm@aemet.es)

### ABSTRACT

The EO-ALERT European Commission H2020 project proposes the definition, development, and verification and validation through ground hardware testing, of a next-generation Earth Observation (EO) data processing chain. The proposed data processing chain is based on a novel flight segment architecture that moves EO data processing elements traditionally executed in the ground segment to on-board the satellite, with the aim of delivering EO products to the end user with very low latency. EO-ALERT achieves, globally, latencies below five minutes for EO products delivery, and below one minute in realistic scenarios.

The proposed EO-ALERT architecture is enabled by on-board processing, recent improvements in processing hardware using Commercial Off-The-Shelf (COTS) components, and persistent space-to-ground communications links. EO-ALERT combines innovations in the on-board elements of the data chain and the communications, namely: on-board reconfigurable data handling, on-board image generation and processing for the generation of alerts (EO products) using Machine Learning (ML) and Artificial Intelligence (AI), on-board AI-based data

compression and encryption, high-speed on-board avionics, and reconfigurable high data rate communication links to ground, including a separate chain for alerts with minimum latency and global coverage.

This paper presents the proposed architecture, its hardware realization for the ground testing in a representative environment and its performance. The architecture's performance is evaluated considering two different user scenarios where very low latency (almost-real-time) EO product delivery is required: ship detection and extreme weather monitoring/nowcasting. The hardware testing results show that, when implemented using COTS components and available communication links, the proposed architecture can deliver alerts to the end user with a latency below five minutes, for both SAR and Optical missions, demonstrating the viability of the EO-ALERT architecture. In particular, in several test scenarios, for both the TerraSAR-X SAR and DEIMOS-2 Optical Very High Resolution (VHR) missions, hardware testing of the proposed architecture has shown it can deliver EO products and alerts to the end user globally, with latency lower than one-point-five minutes.

## INTRODUCTION

Over the past 50 years, the classical EO data chain that has been mastered, involves the acquisition of sensor data on-board the satellite, its compression and storage on-board, and its transfer to ground by a variety of communication means, for later processing on ground and the generation of the downstream EO products. The data provided by this data chain is nowadays ubiquitously used throughout society for a range of diverse applications, such as environment and resource monitoring, emergency management and civilian security [1].

The classical EO data chain generates however a severe bottleneck problem, given the very large amount of EO raw data generated on-board the satellite that must be transferred to ground. This reduces the EO product availability, increasing latency, and hampering applications to grow in accordance with the increased user demand for EO products.

This paper provides an overview of the EO-ALERT project (<http://eo-alert-h2020.eu/>) and the recent hardware results that have been achieved. EO-ALERT is an H2020 European Union research activity led by DEIMOS Space. EO-ALERT proposes the definition and development of the next-generation EO data and processing chain, based on a novel flight segment architecture that moves optimised key EO data processing elements from the ground segment to on-board the satellite. The objective is to deliver the EO products to the end user, globally, with very low latency (almost-real-time).

## LATENCY REQUIREMENTS

Data latency has become a key requirement in the EO market, since end-users require that data is available in a very short time interval. In the case of polar platform satellites, what it is currently referred to as near real-time (NRT) consists of the provision of image products in the range of 1 to 3 hours; e.g. Sentinel-1 makes ocean products available within 1 hour of observation over NRT areas [2]. Local services are also offered in

quasi-real-time, referring to latencies in the order of 15 minutes to 30 minutes, but this importantly is not offered globally [3].

Current market trends are moving beyond NRT applications, to applications with quasi-real-time latencies in the order of 30 minutes to 15 minutes, and provided globally. The latency performance concept behind EO-ALERT is to achieve latencies well below 15 minutes for the EO products delivery. To be precise, the definition of latency can be taken to be: the time from the collection of the last photons by the payload, through to the time that the data is converted to a specified EO product and that this product is delivered to the user (i.e. user portal).

Based on this performance concept, and latency definition, EO-ALERT has a **goal latency of less than one minute**, globally, and requires a **maximum latency of less than 5 minutes**, globally, for both SAR and optical EO products.

## ARCHITECTURE

To achieve the challenging latency objectives, EO-ALERT has performed innovations in both the functional and physical architecture of the EO processing and data chain, from the output of the payload, followed by the on-board processing, through the communications and finally the reception on the ground of the EO products.

### *Functional Architecture*

Figure 1 shows the high-level functional architecture implemented in EO-ALERT. To achieve the target latency in EO products delivery, the proposed functional architecture includes several innovative elements: on-board processing of the payload raw data to L1, processing on-board of the L1 product to generate the EO product (e.g. ship detection alert), reconfigurable on-board data handling to prioritise the EO products over raw data, and multiple communications channels, to provide for a global alerts (EO product) delivery via a satellite-relay.

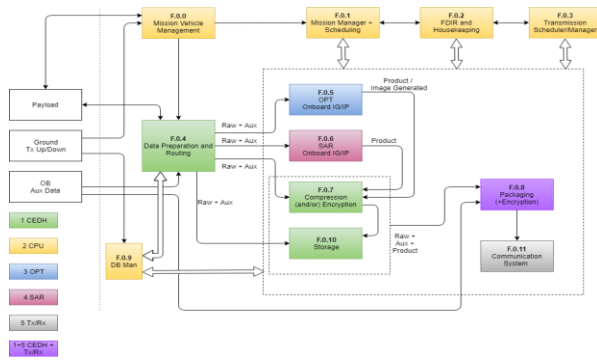

**Figure 1: EO-ALERT top-level functional architecture**

To ensure the system is suitable for several mission scenarios and multiple payload types, the functional architecture is designed to be modular, scalable and reconfigurable. The entire data-chain is divided into several functional blocks, each one implemented on dedicated software and/or hardware computing resources. Each function can be configured or changed with no or little impact on the others, and the available processing power can be assigned to each function based on the mission requirements. With this approach, the system can process different data types (e.g. optical and SAR data) from several sensors, over a wide range of dataset sizes.

More information on the functional elements implemented and verified in the EO-ALERT project can be found in [4], [5], [6], [7] and [8].

### Physical Architecture

#### End-to-end Physical Architecture

The elements of concern to the developments in the EO-ALERT project are those of the image processing chain (IPC), from the payload on-board the satellite, through the on-board data processing unit (the payload data processing unit, PDPU), the flight-to-ground communications subsystem, and finally the ground units for decryption/decompression, as needed.

Here we focus on the physical architecture and HW selection for the PDPU and the communications subsystem.

#### Payload Data Processing Unit Physical Architecture

**Hardware selection:** The physical design of the PDPU avionics is implemented as a hybrid solution, i.e. a solution that uses both Commercial Off-The-Shelf (COTS) and space qualified components. COTS are used in conjunction with mitigation techniques to increase robustness of the design against radiation effects, whereas space qualified components are used

for the critical functions. This choice allows keeping weight, volume and cost of the Payload Data Processing Unit (PDPU) low with respect to an all space-grade design and it takes advantage of the state-of-the-art technology and processing power of the latest COTS components. This last point has proven to be fundamental to reach the project's latency goals.

Reliability in the Low Earth Orbit (LEO) environment is addressed through the employment of radiation mitigation techniques, redundancy, extensive telemetry collection and Fault Detection, Isolation and Recovery (FDIR) actions so that the solution is more robust than an all-COTS design.

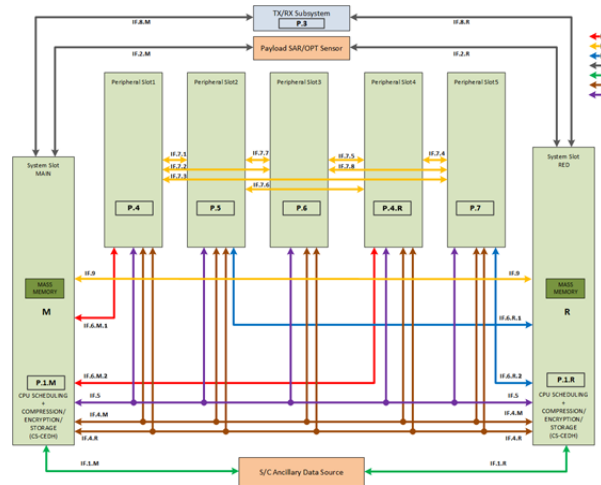

**Figure 2: EO-ALERT top-level PDPU physical architecture**

**Physical Architecture for the PDPU:** The top-level physical architecture of the EO-ALERT PDPU is shown in Figure 2. The PDPU weighs less than 8kg in a 10U volume, although smaller Size, Weight and Power (SWaP) constraints can be met if needed. The architecture is based on the Compact Peripheral Component Interconnect (cPCI) Serial Space standard which guarantees a modular and scalable approach to on-board processing. This standard provides a backplane with two system slots and up to seven peripheral boards. The whole system is supervised by a shelf controller that can check the status of the boards and control their power supply.

The system slots are at the centre of a star connection with point-to-point high-speed links to the peripheral boards, which in turn are interconnected with a mesh of high-speed links.

In the EO-ALERT configuration system slots are used for scheduling, compression, encryption and data handling tasks, while five peripheral slots are dedicated

to processing functions. Each system slot is connected directly, using the star links, to two “Master” processing boards. Master boards can offload computation to slave boards using mesh links.

Each peripheral board can be reconfigured from System Boards to handle optical (Visible Near Infrared VNIR, TIR) or SAR data so that the system can dynamically adapt to workloads and recover from failures; the two system slots implement an intrinsic redundancy without the need of duplicating the entire PDPU.

The shelf controller design features all space-grade components and contains Latch-up Current Limiting (LCL) circuitry for each board and a supervising microcontroller. All boards are based on the powerful Xilinx Zynq US+ ZU19EG Multi-processor System-on-Chip (MPSoC), featuring a quad core ARM processor and a large Field-Programmable Gate Array (FPGA) built onto the same die.

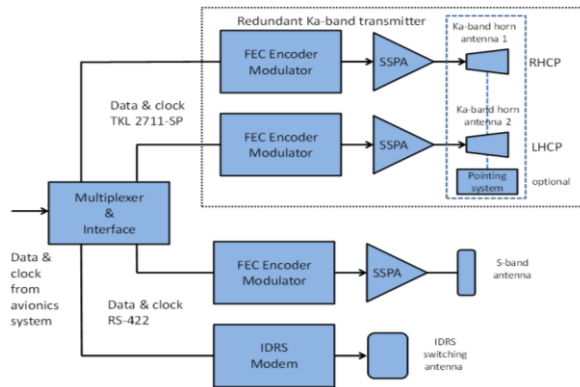

**Figure 3: EO-ALERT communications physical architecture**

### Communications Physical Architecture

Figure 3 depicts the block diagram of the communications system for EO-ALERT. It consists of a redundant Ka-band transmitter, an S-band downlink chain for local alert delivery and the INMARSAT iDRS modem for global alert delivery.

Processed data from the avionics system enter a multiplexer which directs the data to the relevant subsystem:

- Raw data, processed images and alerts are forwarded to the Ka-band system
- Alerts are sent simultaneously to the S-band transmitter and the iDRS modem

The Ka-band transmitter consists of a forward-error-correction encoder, a modem and a solid-state power

amplifier with an output power of 10 W. QPSK, 8PSK, 16APSK, 32APSK and 64APSK are the envisaged modulation schemes, the coding scheme is SCCC (serial concatenated convolutional coding). Data rates up to 2.6 Gbit/s are supported by a commercial product offered by TESAT. In our case the effective user data rate was set to 1.8 Gbit/s. The Ka-band transmitter is fully redundant, feeding horn antennas, one for right-hand circular polarisation, the other one for left-hand circular polarisation.

The S-band system for local alert transfer consists of an FEC encoder (LDPC), a QPSK modulator, an SSPA and a patch antenna, supporting a data rate of 1 Mbit/s to small hand-held terminals for rescue teams.

The iDRS modem for global alert transmission is connected to a switching antenna composed of 7 patches. The patch with best coverage to an INMARSAT satellite is automatically activated. The maximum data rate is 250 kbit/s.

### REFERENCE SCENARIOS

Two reference scenarios are used in EO-ALERT to test and demonstrate, using real satellite and EO payload data, the correctness of the architecture and the performance of the system. More information can be found in [9].

#### Ship Detection Scenario

A very low latency ship detection and monitoring service was selected as one of the reference scenarios. The intention was to be able to develop on-board the satellite an alert, similar to the EMSA Vessel Detection System (VDS), and send this directly to an end user globally, including the following parameters, with a very short latency (goal of 1 minute, requirement below 5 minutes):

- Position & movement (velocity, heading).
- Ship details (size, width, etc)
- Ship image (clipping thumbnail)

Both a SAR (TerraSAR-X) and Optical (DEIMOS-2) satellite, with VHR payload, are used to assess this service.

#### Extreme Weather Scenario

For the extreme weather scenario, two types of detections have been considered: convective storms (nowcasting) and wind speed.

**Convective Storm Nowcasting:** A very low latency meteorological nowcasting service for severe convective storms was selected as one of the extreme weather scenarios. The intention is to develop on-board the satellite an alert, similar to the NWCSAF [10] RDT-CW (Rapidly Developing Thunderstorms – Convection Warning), and send this directly to an end user globally. For this the SEVIRI optical VIS/TIR instrument, on-board the MSG satellite, is used to assess this service.

**Sea Sate Wind Speed:** A very low latency maritime wind speed and wave height service was selected as one of the extreme weather scenarios. This uses SAR (TerraSAR-X) satellite data to derive the desired information directly from the sea surface.

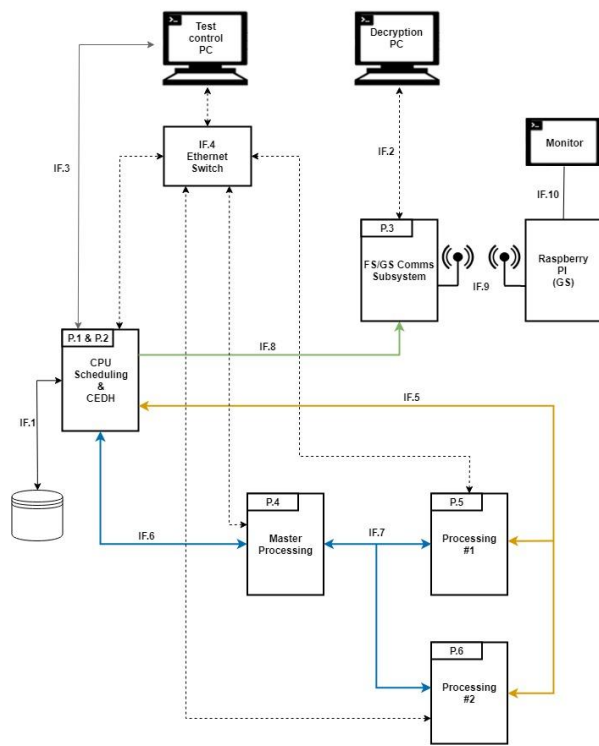
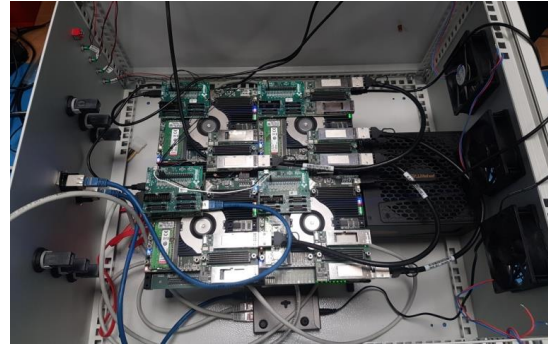

**Figure 4: Test-Bench Architecture**

**TESTBENCH**

In order to perform the verification and validation activities of the EO-ALERT architecture, an avionics test-bench is employed (Figure 4). The Avionics Test-Bench (ATB) consists of representative test environment for the full EO-ALERT image processing chain. It includes a scaled-down version of the PDPU subsystem design (Figure 5), composed by commercial hardware (not cPCI Serial Space compliant) and offering four boards instead of seven. The ATB includes a transceiver/receiver communications

subsystem emulator and communications hardware (Figure 6), which is needed to test the transmission to the Ground Segment (GS), both using the satellite relay (L-band GEO-relay, Figure 8) and the different direct-to-ground channels (Ka-band and S-band, Figure 6 and Figure 7).



**Figure 5: Scaled-down PDPU implementation in the Test-bench**



**Figure 6: Communications Emulator for the complete subsystem: S-band transmitter, link controller for the iDRS transceiver, Ethernet switch and power supplies, with Ka-band emulated**



**Figure 7: Handheld device and touch screen for the direct Space-to-ground decryption and visualization (used for the S-band data link transfers)**



**Figure 8: iDRS unit terminal and receiver for the global persistent communications unit hardware in the test-bench**

### END-TO-END DATA CHAIN RESULTS

A key outcome of the EO-ALERT project to date is that the performance of the data chain has been confirmed, both analytically and through hardware testing, covering the full data chain (payload to ground). This section presents the results of the project in terms of the current latency of the EO products, in the different reference scenarios.

#### *Ship Detection Scenario Results*

The ATB, including the communications units and emulator, have been used in ground testing to quantify the latency of the ship detection service.

For the ship scenario, the optical processing uses the optical DEIMOS-2 VHR satellite raw data. The testing is performed in a configurable multi-board scheme. Each board processes about 100 km<sup>2</sup> at ~0.9m resolution. To process this area, the entire on-board processing chain (Figure 9), from raw data to EO product delivery to the communications subsystem, takes less than 45 s running on a single Xilinx Zynq US+ board. Including the communication of alerts (ship detection and thumbnail image) through a global communications link, the total time is for alert generation and delivery is typically less than 1.5 minutes, and below 1 minute in the case that the number of alerts to be transmitted is small (i.e. less than 20 ship detection alerts). If the processing is parallelized over multiple boards, the ship service can be performed in less than 1 minute in all scenarios. More information on the optical processing chain for ship detection, and HW testing, can be found in [4], [5].

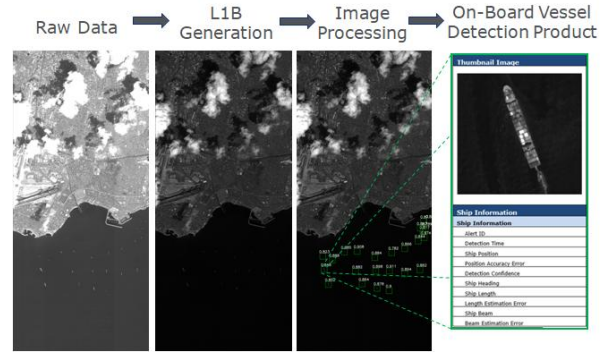

**Figure 9: Optical on-board ship detection processing chain to the provision of EMSA VDS-like EO products (alerts).**

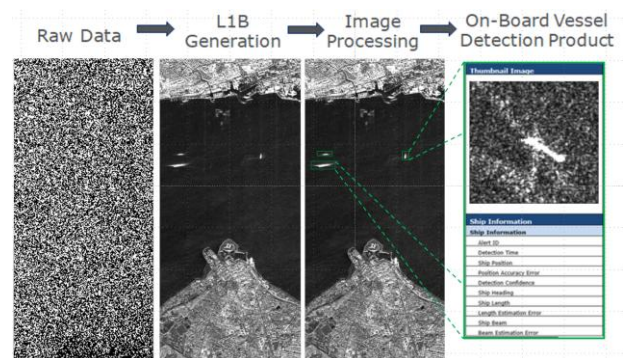

**Figure 10: SAR on-board ship detection processing chain tested on TerraSAR-X EO payload data for the provision of ship detection alerts.**

For the ship scenario, the SAR processing uses the SAR TerraSAR-X satellite data. The testing is performed in a single-board scheme. Each board processes about 400 km<sup>2</sup> at ~4m resolution. The entire on-board processing chain (see Figure 10) takes less than 40 s running on a single Xilinx Zynq US+ board. Including the communication of alerts (ship detection and thumbnail image) through a global communications link, the total time is for alert generation and delivery is typically less than 1.5 minutes, and below 1 minute in the case that the number of alerts to be transmitted is small (i.e. less than 20 ship alerts).. More information on the SAR processing chain can be found in [6].

#### *Extreme Weather Scenario Results*

The ATB has also been used in ground testing to quantify the latency of the extreme weather service.

For the extreme weather scenario for wind speed and wave height, using the satellite TerraSAR-X data, the latency for the product provision is similar to that for the ship scenario with SAR. The total time for alert generation and delivery is less than 1.5 minutes. More information can be found in [6].

For the extreme weather nowcasting for convective storm detection and monitoring, using SEVIRI optical VIS/TIR data, the total time for alert generation (see Figure 11) and delivery is less than 1 minute, noting that in this case, due to the GEO satellite use, both a direct-to-ground and global communications link suffice. More information on the extreme weather processing chain and scenario in can be found in [8].

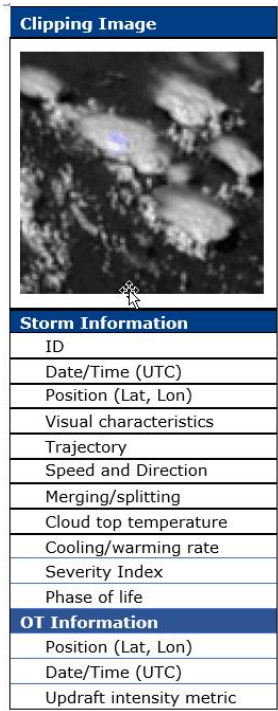

**Figure 11: Optical on-board Extreme Weather Nowcasting tested on MSG SEVIRI payload data for the provision of extreme weather alerts similar to that of the EUMETSAT RDT product: example storm thumbnail and support data.**

## CONCLUSIONS

The EO-ALERT EO data processing chain and architecture, based on a novel flight segment architecture enabled by on-board processing, recent improvements in processing hardware using Commercial Off-The-Shelf (COTS) components, and persistent space-to-ground communications links, has been shown to be feasible and performing through avionics test-bench testing. The architecture provides the service of delivery of EO products to the end user with very low latency (in almost-real-time). Hardware testing shows latencies below 1.5 minutes for EO products delivery, globally, in all scenarios, reaching latencies below 1 minute in some scenarios, such as the ship detection service when the on-board processing is parallelized or the number of alerts is limited. Further ATB testing during Q3 2021 aims to demonstrate the

complete viability of the EO-ALERT concept and architecture, and fully assess its performance. This will lead to the achievement of TRL 4-5 maturity for the architecture and technologies, positioning the EO-ALERT architecture and technologies for use in upcoming programmes, where EO product latency, and general satellite autonomy, are key mission enablers.

## Acknowledgments

The research leading to this publication has received funding from the European Union's Horizon 2020 research and innovation programme under grant agreement No 776311.

## References

1. Business Innovation Observatory. Applications related to Earth Observation. Study Case 63. Ares(2016)2153857 - 06/05/2016
2. <https://sentinel.esa.int/web/sentinel/missions/sentinel-1/data-distribution-schedule>
3. <https://sentinels.copernicus.eu/web/sentinel/missions/collaborative/categories/data-acquisition-production>
4. F. Membibre, et. al., "PIL testing of the Optical On-board Image Processing Solution for EO-ALERT", ESA OBDP, 2021.
5. A. Latorre, et. al., "On-board Low Latency Processing of Earth Observation Products in a Multi-board Scheme Using Multi-core and FPGA-based Architecture", IAC 2020, October 2020.
6. S. Wiehle, et. Al., "SAR satellite on-board ship, wind, and sea state detection", IGARSS, 2021.
7. M. Caon, et. al. ,"Very low latency architecture for earth observation satellite onboard data handling, compression, and encryption", IGARSS, 2021.
8. R. Hinz, et. al, "EO-ALERT: Machine Learning-Based On-Board Satellite Processing for Very-Low Latency Convective Storm Nowcasting", ECMWF-ESA Workshop on Machine Learning for Earth System Observation and Prediction, 2020.
9. S. Tonetti, et. al., "EO-ALERT: Next Generation Satellite Processing Chain for Security-Driven Early Warning Capacity in Maritime Surveillance and Extreme Weather Events", ESA Living Planet Symposium, 2019.
10. <http://www.nwcsaf.org/>, last retrieved 18/09/2020