

EO-Alert: A Satellite Architecture for Detection and Monitoring of Extreme Events in Real Time

Original

EO-Alert: A Satellite Architecture for Detection and Monitoring of Extreme Events in Real Time / Kerr, M., Tonetti, S., Carnara, S., Bravo, J.I., Hinz, R., Latorre, A., Membibre, F., Ramos, A., Wiehle, S., Koudelka, O., Magli, E., Freddi, R., Fraile, S., Marcos, C.. - ELETTRONICO. - (2021), pp. 168-171. (2021 IEEE International Geoscience and Remote Sensing Symposium IGARSS Brussels, Belgium 11-16 July 2021) [10.1109/IGARSS47720.2021.9554747].

Availability:

This version is available at: 11583/2938200 since: 2021-11-16T16:35:51Z

Publisher:

IEEE

Published

DOI:10.1109/IGARSS47720.2021.9554747

Terms of use:

This article is made available under terms and conditions as specified in the corresponding bibliographic description in the repository

Publisher copyright

IEEE postprint/Author's Accepted Manuscript

©2021 IEEE. Personal use of this material is permitted. Permission from IEEE must be obtained for all other uses, in any current or future media, including reprinting/republishing this material for advertising or promotional purposes, creating new collecting works, for resale or lists, or reuse of any copyrighted component of this work in other works.

(Article begins on next page)

EO-ALERT: A SATELLITE ARCHITECTURE FOR DETECTION AND MONITORING OF EXTREME EVENTS IN REAL TIME

*M. Kerr^a, S. Tonetti^a, S. Cornara^a, J. I. Bravo^a, R. Hinz^a, A. Latorre^a, F. Membibre^a, A. Ramos^a,
S. Wiehle^b, O. Koudelka^c, E. Magli^d, R. Freddi^e, S. Fraile^f, C. Marcos^g*

^a DEIMOS Space S.L.U., Tres Cantos – Madrid, Spain, Email: murray.kerr@deimos-space.com

^b Deutsches Zentrum für Luft- und Raumfahrt e.V., Germany

^c Technische Universität Graz, Graz, Austria ^d Politecnico di Torino, Turin, Italy

^e OHB Italia Spa, Milan, Italy ^f Deimos Imaging S.L.U., Spain ^g Agencia Estatal de Meteorología, Spain

ABSTRACT

This paper presents the architecture and results achieved by the EO-ALERT H2020 project. EO-ALERT proposes the definition and development of the next-generation Earth Observation (EO) data processing chain, based on a novel flight segment architecture that moves optimised key EO data processing elements from the ground segment to on-board the satellite, with the aim of delivering the EO products to the end user with very low latency (in almost real-time). This paper presents the EO-ALERT architecture, its performance and hardware. Performances are presented for two reference user scenarios; ship detection and extreme weather nowcasting/monitoring. The hardware testing results show that, when implemented using Commercial Off-The-Shelf (COTS) components and available communication links, the proposed architecture can deliver EO products and alerts to the end user with a latency lower than one-point-five minutes, for both SAR and Optical Very High Resolution (VHR) missions, demonstrating the viability of the EO-ALERT concept and architecture.

Index Terms— On-Board Processing, AI, Low Latency

1. INTRODUCTION

The classical EO data chain generates a severe bottleneck problem, given the very large amount of EO raw data generated on-board current and up-coming satellites that must be transferred to ground, reducing responsiveness, increasing latency, and hampering EO applications to grow in accordance with the increased user demand. EO-ALERT [1] (<http://eo-alert-h2020.eu/>) proposes to solve this problem through the definition and development of the next-generation EO processing chain, that delivers globally and directly the EO products to the end user, with very low latency (in almost real-time).

Achieving this goal poses great challenges on the flight system. In EO-ALERT, this is addressed through a combination of innovations in the on-board elements of the

data chain and the communications link. As such, this goal necessitates innovation in several critical technological areas; namely on-board reconfigurable data handling, on-board image generation, on-board image processing for the EO products generation, high-speed on-board avionics, on-board data compression and encryption, and reconfigurable high data rate communication links to ground, while also exploiting machine learning (ML)/artificial intelligence (AI).

The paper presents the project results, with particular attention to the overall performance of the EO data chain.

2. EO-ALERT OBJECTIVES

Data latency has become a key requirement in the EO market, since many end-users require data to be available in a very short time interval. In the case of polar or near-polar satellites, what is currently referred to as Near Real-Time (NRT) consists of the provision of image products in the range of 1 to 3 hours. Current market trends are moving beyond NRT applications, to applications with latencies in the order of 30 minutes to 15 minutes. Based on this, and upcoming market needs, the latency performance concept behind EO-ALERT is to achieve latencies well below 15 minutes for the EO products for their delivery globally to the end user. EO-ALERT has a **goal latency of less than one minute and requires a maximum latency of less than 5 minutes**, for both SAR and optical VHR image products.

In EO-ALERT, a further key objective is that both the technologies and the integrated data chain, from the payload to ground reception of the EO products, are **verified and experimentally validated on an avionics test-bench**, allowing the achievement of TRL 4/5 for the concept. This verification of the technologies and data chain uses both archive data from multiple satellites (TerraSAR-X for SAR, DEIMOS-2 for Optical and MSG/SEVIRI for Multi-Spectral MS/Thermal InfraRed TIR) and experimental EO data acquired specifically for EO-ALERT. The testing is performed on two example reference scenarios, where EO product latency is a key driver: ship detection and extreme weather monitoring/nowcasting.

3. EO-ALERT ARCHIECTURE

To achieve the challenging latency objectives, EO-ALERT has performed innovations in both the functional and physical architecture of the EO processing and data chain, from the output of the payload through the communications and reception on ground.

3.1. Functional Architecture

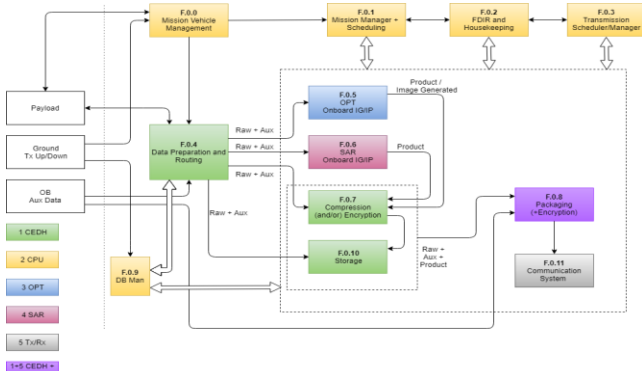

Fig. 1: EO-ALERT top-level functional architecture.

Figure 1 shows the high level functional architecture selected and implemented in EO-ALERT. To achieve the target latency in EO products delivery, the proposed functional architecture includes several innovative elements: on-board processing of the payload raw data to L1, processing of the on-board L1 product to generate the EO product (e.g. ship detection alert) ([2],[3]), reconfigurable data handling to prioritise the EO products over raw data [4], and multiple communications channels, to provide for a global alerts (EO product) delivery via a satellite-relay and a traditional bulk raw data delivery service via direct to ground links (Ka-band) [5].

To ensure the system is suitable for several mission scenarios and multiple payload types, the functional architecture is designed to be modular, scalable and reconfigurable. The entire data-chain is divided into several functional blocks, each one implemented on dedicated software and/or hardware computing resources. Each function can be configured or changed with no or little impact on the others, and the available processing power can be assigned to each function based on the mission requirements. With this approach, the system can process different data types (e.g. optical and SAR data) from several sensors over a wide range of dataset sizes.

3.2 On-board Processing Hardware Selection

The physical design of the avionics is implemented as a hybrid solution, i.e. a solution that uses both Commercial Off-The-Shelf (COTS) and space qualified components [6]. COTS are used in conjunction with mitigation techniques to

increase robustness of the design against radiation effects, whereas space qualified components are used for the critical functions. This choice allows keeping weight, volume and cost of the Payload Data Processing Unit (PDP) low with respect to an all space-grade design and it takes advantage of the state-of-the-art technology and processing power of the latest COTS components. This last point has proven to be fundamental to reach the project’s latency goals.

Reliability in the Low Earth Orbit (LEO) environment is addressed through the employment of radiation mitigation techniques, redundancy, extensive telemetry collection and Fault Detection, Isolation and Recovery (FDIR) actions so that the solution is more robust than an all-COTS design.

3.3 Physical Architecture for the PDP

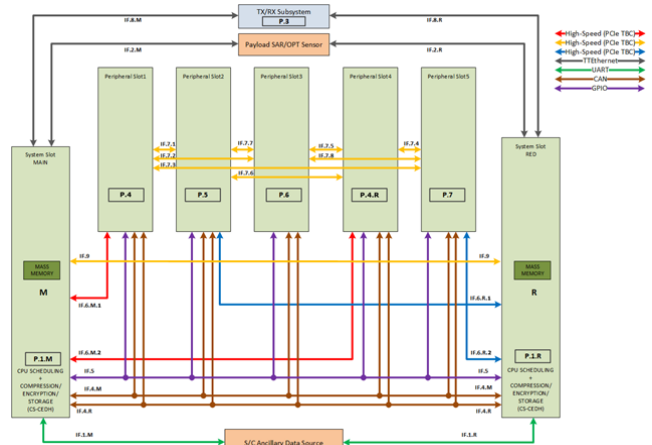

Fig. 2: EO-ALERT top-level physical architecture.

The top-level physical architecture of the EO-ALERT PDP is shown in Fig. 2. The PDP weighs less than 8kg in a 10U volume, although much smaller Size, Weight and Power (SWaP) constraints can be met if needed. The architecture is based on the Compact Peripheral Component Interconnect (cPCI) Serial Space standard which guarantees a modular and scalable approach to on-board processing [7]. This standard provides a backplane with two system slots and up to seven peripheral boards. The whole system is supervised by a shelf controller that can check the status of the boards and control their power supply.

The system slots are at the centre of a star connection with point-to-point high-speed links to the peripheral boards, which in turn are interconnected with a mesh of high-speed links.

In the EO-ALERT configuration (Fig. 2) system slots are used for scheduling, compression, encryption and data handling tasks, while five peripheral slots are dedicated to processing functions. Each system slot is connected directly, using the star links, to two “Master” processing boards. Master boards can offload computation to slave boards using mesh links.

Each peripheral board can be reconfigured from System Boards to handle optical (Visible Near InfraRed VNIR, TIR) or SAR data so that the system can dynamically adapt to workloads and recover from failures; the two system slots implement an intrinsic redundancy without the need of duplicating the entire PDPU.

The shelf controller design features all space-grade components and contains Latch-up Current Limiting (LCL) circuitry for each board and a supervising microcontroller. All boards are based on the powerful Xilinx Zynq US+ ZU19EG Multi-processor System-on-Chip (MPSoC), featuring a quad core ARM processor and a large Field-Programmable Gate Array (FPGA) built onto the same die.

4. REFERENCE SCENARIOS

Two reference scenarios are used in EO-ALERT to test and demonstrate, using real satellite and EO payload data, the correctness of the architecture and the performance of the system. More information can be found in [1].

4.1 Ship Detection Scenario

A very low latency ship detection and monitoring service was selected as one of the reference scenarios. The intention is to be able to develop on-board the satellite an alert, similar to the EMSA Vessel Detection System (VDS), and send this directly to an end user, including the following parameters, with a very short latency (goal of 1 minute, requirement below 5 minutes):

- Position & movement (velocity, heading).
- Ship details (size, width, etc)
- Ship image (clipping thumbnail)

Both a SAR (TerraSAR-X) and Optical (DEIMOS-2) satellite, with VHR payload, are used to assess this service.

4.2 Extreme Weather Scenario

For the extreme weather scenario, two types of detections have been considered: convective storms and wind speed.

4.2.1 Convective Storm Nowcasting

A very low latency meteorological nowcasting service for severe convective storms was selected as one of the extreme weather scenarios. The intention is to develop on-board the satellite an alert, similar to the NWCSAF [8] RDT-CW (Rapidly Developing Thunderstorms – Convection Warning), and send this directly to an end user. For this the SEVIRI optical VIS/TIR instrument, on-board the MSG satellite, is used to assess this service.

4.2.2 Wind Speed

A very low latency maritime wind speed and wave height service was selected as one of the extreme weather scenarios. This uses SAR (TerraSAR-X) satellite data to derive the desired information directly from the sea surface.

5. AVIONICS TEST BENCH

In order to perform the verification and validation activities of the EO-ALERT architecture, an avionics test-bench is employed. More information can be found in [1]. The Avionics Test-Bench (ATB) consists of a scaled-down version of the PDHU subsystem design, composed by commercial hardware (not cPCI Serial Space compliant) and offering four boards instead of seven (Fig.3). The ATB includes a transceiver/receiver subsystem emulator and communications hardware, which is needed to test the transmission to the Ground Segment (GS), both using the satellite relay (L-band GEO-reply) and the different direct-to-ground channels (Ka-band and S-band).

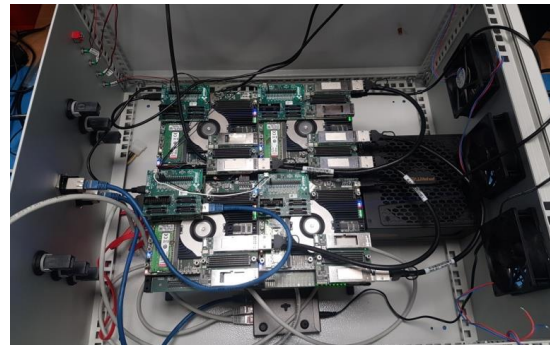

Fig. 3: ATB implementation of the PDHU.

6. FULL DATA CHAIN RESULTS

A key outcome of the EO-ALERT project to date is that the **performance of the data chain has been confirmed**, both analytically and through hardware testing. This section presents the results of the project in terms of the current latency of the EO products, in the different reference scenarios.

6.1 Ship Detection Scenario Results

The ATB and the communications units and emulator, have been used in ground testing to quantify the latency of the ship detection service.

For the ship scenario, the optical processing uses the optical DEIMOS-2 VHR satellite raw data. The testing is performed in a configurable multi-board scheme. Each board processes about 100 km² at ~0.9m resolution. To process this area, the entire on-board processing chain from raw data to EO product delivery to the communications subsystem takes less than 45 s running on a single Xilinx Zynq US+ board. See Fig.4. Including the communication of up to 100 alerts (ship detection and thumbnail image) through a global communications link, the total time is for alert generation and delivery is **less than 1.5 minutes**. If the processing is parallelized over multiple boards, the ship service can be performed in **less than 1 minute**. More

information on the optical processing chain for ship detection can be found in [2].

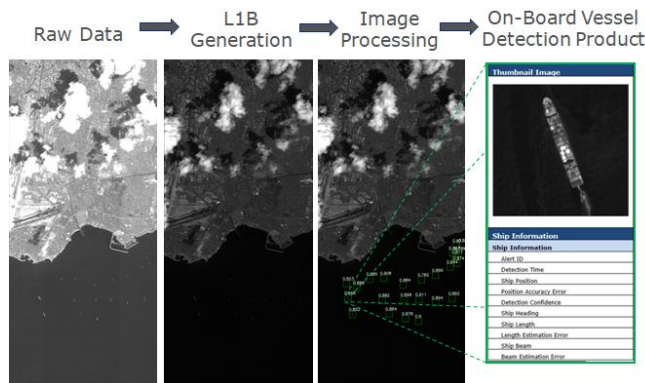

Fig. 4: Optical on-board ship detection processing chain to the provision of EMSA VDS-like EO products (alerts).

For the ship scenario, the SAR processing uses the SAR TerraSAR-X satellite data. The testing is performed in a single-board scheme. Each board processes about 400 km² at ~4m resolution. The entire on-board processing chain takes less than 40 s running on a single Xilinx Zynq US+ board. Including the communication of up to 100 alerts (ship detection and thumbnail image) through a global communications link, the total time is for alert generation and delivery is **less than 1.5 minutes**. More information on the SAR processing chain can be found in [3].

6.2 Extreme Weather Scenario Results

The ATB has also been used in ground testing to quantify the latency of the extreme weather service.

For the extreme weather scenario for wind speed and wave height, using the satellite TerraSAR-X data, the latency for the product provision is similar to that for the ship scenario with SAR. The total time for alert generation and delivery is **less than 1.5 minutes**. More information can be found in [3].

For the extreme weather nowcasting for convective storm detection and monitoring, using SEVIRI optical VIS/TIR data, the total time for alert generation and delivery is **less than 1 minute**, noting that in this case, due to the GEO satellite use, both a direct-to-ground and global communications link suffice. More information on the extreme weather processing chain and scenario in [9].

7. CONCLUSIONS

The proposed EO-ALERT EO data processing chain and architecture, based on a novel flight segment architecture that moves optimised key EO data processing elements from the ground segment to on-board the satellite, has been shown to be feasible and performing through initial avionics test-

bench testing. The architecture provides the service of delivery of EO products to the end user with very low latency (in almost real-time). Hardware testing shows latencies below 1.5 minutes for EO products delivery in all scenarios, reaching latencies below 1 minute in some scenarios, such as the ship detection service when the on-board processing is parallelized. Further testing during 2021 aims to demonstrate the complete viability of the EO-ALERT concept and architecture, and fully assess its performance, while achieving TRL 5 maturity for the architecture and technologies, serving to mature the technology for use in upcoming programmes.

8. ACKNOWLEDGEMENTS

The research leading to this publication has received funding from the European Union's Horizon 2020 research and innovation programme under grant agreement No 776311.

9. REFERENCES

- [1] M. Kerr, et. al., "EO-ALERT: A Novel Architecture for the Next Generation of Earth Observation Satellites Supporting Rapid Civil Alerts", IAC 2020, October 2020.
- [2] A. Latorre, et. al., "On-board Low Latency Processing of Earth Observation Products in a Multi-board Scheme Using Multi-core and FPGA-based Architecture", IAC 2020, October 2020.
- [3] S. Wiehle, et. Al., "SAR satellite on-board ship, wind, and sea state detection", IGARSS, 2021 (submitted).
- [4] M. Caon, et. al. ,"Very low latency architecture for earth observation satellite onboard data handling, compression, and encryption", IGARSS, 2021 (submitted).
- [5] O. Koudelka, et. al., "Advanced Communications Solutions for the Next Generation of Earth Observation Satellites", IAC 2020, October 2020.
- [6] D. Sinclair, J. Dyer, "Radiation effects and COTS parts in SmallSats", Conference on Small Satellites, SSC13-IV-3K, 2013.
- [7] D. Gleeson, M. Melicher, "The smart backplane – lowering the cost of spacecraft avionics by improving the radiation tolerance of COTS electronic systems", in 33rd Space Symposium, 2017.
- [8] <http://www.nwcsaf.org/>, last retrieved 18/09/2020
- [9] R. Hinz, et. al., "EO-ALERT: Machine Learning-Based On-Board Satellite Processing for Very-Low Latency Convective Storm Nowcasting" in EMCWF-ESA workshop, October 2020.