

Creep behaviour of two-component grout and interaction with segmental lining in tunnelling

Original

Creep behaviour of two-component grout and interaction with segmental lining in tunnelling / Oggeri, C., Oreste, P., Spagnoli, G.. - In: TUNNELLING AND UNDERGROUND SPACE TECHNOLOGY. - ISSN 0886-7798. - STAMPA. - 119:(2022). [10.1016/j.tust.2021.104216]

Availability:

This version is available at: 11583/2931553 since: 2021-10-14T17:57:17Z

Publisher:

Elsevier

Published

DOI:10.1016/j.tust.2021.104216

Terms of use:

This article is made available under terms and conditions as specified in the corresponding bibliographic description in the repository

Publisher copyright

Elsevier postprint/Author's Accepted Manuscript

© 2022. This manuscript version is made available under the CC-BY-NC-ND 4.0 license
<http://creativecommons.org/licenses/by-nc-nd/4.0/>. The final authenticated version is available online at:
<http://dx.doi.org/10.1016/j.tust.2021.104216>

(Article begins on next page)

1 **Creep behaviour of two-component grout and interaction with segmental lining in**
2 **tunnelling**

3 Claudio Oggeri¹, Pierpaolo Oreste¹, Giovanni Spagnoli^{2*}

4 ¹ Department of Environment, Land and Infrastructure Engineering, Politecnico di Torino,
5 Corso Duca Degli Abruzzi 24, 10129 Torino, Italy

6 ² MBCC Group, Dr-Albert-Frank-Strasse 32, 83308 Trostberg, Germany, Tel: +49 8621 86-
7 3702, *giovanni.spagnoli@mbcc-group.com* ORCID: 0000-0002-1866-4345

8 (CORRESPONDING AUTHOR)

9 **Abstract**

10 The complexity of the two-component grout behavior significantly affects the interaction
11 between the support system and the tunnel. The loading of the filling material (and also of
12 the segmental lining) takes place during the curing phase. At the end of it a creep phase
13 develops which shows secondary deformations over time which result in a relaxation of the
14 segmental lining and an increase in the deformation of the tunnel wall. In this work, a
15 laboratory experiment campaign allowed to study the two-component material in detail
16 during the creep phase. The typical trend of deformations over time, obtained for different
17 stress load values and material curing age, was identified. The maximum stress was also
18 evaluated which still allows to avoid the failure of the material over time, when a persistent
19 state of stress is applied. The information obtained from the experimentation allowed to
20 provide considerations on the support system-tunnel interaction, using the convergence-
21 confinement method. The approach followed was then applied to a real case of a tunnel
22 excavated in Northern Italy, for which it was possible to estimate the decrease in the load
23 applied to the support system and the increase in deformations of the tunnel wall due to the
24 creep phenomenon of the two-component material.

25 **Key words:** two-component grout; curing age; Tunnel Boring Machine (TBM); convergence-
26 confinement method (CCM); creep-behaviour.

27

28 **Abbreviations and nomenclature**

- 29 E_{fm} Elastic modulus of the filling material
- 30 E_{gr} Elastic modulus of the ground
- 31 E_s Secant elastic modulus
- 32 E_{sl} Elastic modulus of the segmental lining (concrete)
- 33 E_t Tangent elastic modulus
- 34 $E_{t,\alpha}$ Tangent elastic modulus of the filling material associated with a percentage load level
- 35 α referred to the Unconfined Compressive Strength (UCS)
- 36 $E_{t,35\%}$ Tangent modulus of elasticity measured at a stress level equal to 35% of UCS
- 37 $k_{sys,fin}$ Stiffness of the support system at the end of the loading process
- 38 k_{sys} Stiffness of the support system
- 39 $k_{sys,in}$ Stiffness of the support system at the beginning of the loading process
- 40 k_{sl} Radial stiffness of the segmental lining
- 41 k_0 Coefficient of earth pressure at rest
- 42 p Pressure inside the tunnel acting on the walls
- 43 p_{eq} Final entity of the loads acting on the support system
- 44 p_0 Hydrostatic initial stress state (undisturbed)
- 45 R Tunnel radius
- 46 t_{fm} Thickness of the filling material

47	t_{sl}	Thickness of the segmental lining
48	UCS	Unconfined compressive strength
49	u_{eq}	Final entity of the tunnel wall displacement
50	u_0	Displacement of the tunnel wall when the support system is installed
51	u_{max}	Maximum displacement of the tunnel wall in the absence of supports
52	ν_{fm}	Poisson's ratio of the filling material
53	ν_{gr}	Poisson's ratio of the soil or rock present around the tunnel
54	ν_{sl}	Poisson's ratio of the concrete constituting the segmental lining
55	α	Percentage of the stress level acting in the filling material with respect to the UCS
56		strength
57	δ_{inst}	Immediate displacement in the filling material
58	ε	strain (ratio of the the displacement on the reference height)
59	ε_{creep}	creep strain of the filling material
60	ε_{inst}	Immediate deformation of the filling material
61	η	Long-term strength of the two-component material as a percentage of the UCS
62	ω	Correction coefficient taking into account the deformation increase that occurs in the
63		first 10 minutes of load during a creep test
64	σ	Applied or induced stress

65 Δu Increase in the radial displacement of the tunnel wall due to the creep phenomenon
66 of the filling material

67

68 **Introduction**

69 The backfilling (or tail void grouting) is the system used during the excavation of a tunnel by
70 means of a TBM (Tunnel Boring machine) to fill the void created during the advancement of
71 the machine between the support structure and the rock wall. As a matter of fact, when
72 tunneling is carried out using a shield machine and a segmental lining, there is a gap caused
73 by the overcut due to the slightly larger diameter of the shield machine than the lining
74 (Sharghi et al., 2018) and to the thickness of the shield and the space occupied by the
75 brushes, which close the void lining-shield (see Fig. 1). This gap is needed in order for the
76 TBM to curve left/right (planimetric curves) or up/down (altimetric curves).

77 The instantaneous filling of the annulus that is created behind the segment lining at the end
78 of the TBM tail during its advancement is a very important operation. The objective is to
79 minimize the surface settlements induced by the passage of the TBM, to assure that the
80 tunnel convergence is within the allowable limit, to ensure the homogeneous transmission
81 of stresses between the soil/rock mass and the lining, to avoid misalignments of the linings
82 and to provide impermeabilization of the tunnel (Thewes and Budach, 2009; Di Giulio et al.,
83 2020; Oggeri et al., 2021). Different types of materials are used to fill the gap, however lately
84 the two-component grout system is becoming more popular (e.g. Di Giulio et al., 2020;
85 Oggeri et al., 2021; Rahmati et al., 2021). To correctly achieve this, a simultaneous
86 backfilling system and the injected material should satisfy the technical, operational and
87 performance characteristics: the two-component grout must be water-tight, pumpable,
88 workable, able to fill the void, to stiff quickly and to be wash-out resistant, not able to shrink
89 (e.g. Thewes and Budach, 2009; Oggeri et al., 2021).

90 For these reasons, the open space must be continuously filled during the machine's
91 advancement.

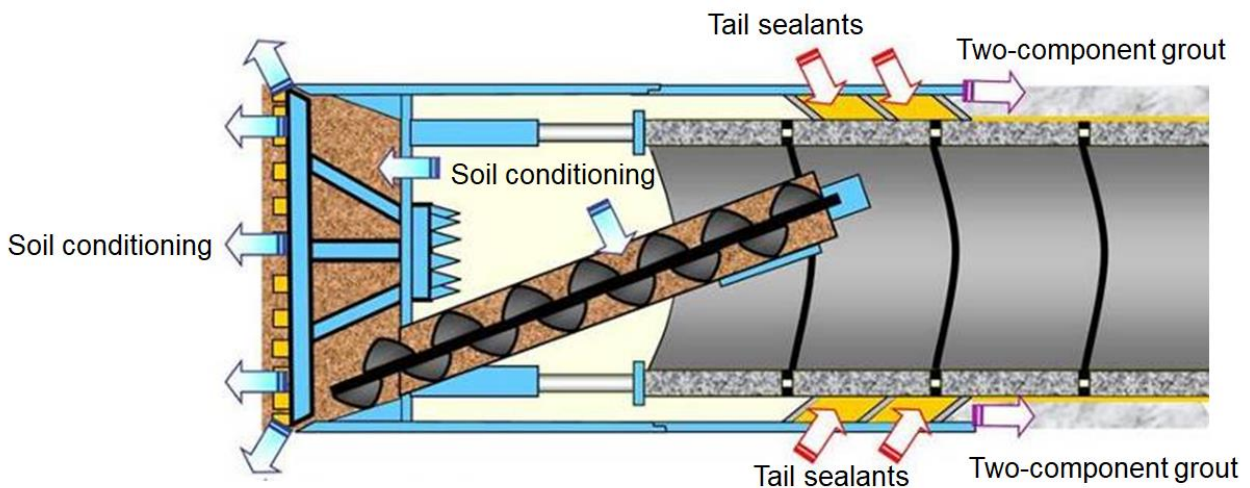

92

93 **Fig. 1 Section of EPB-TBM with some main aspects highlighted**

94 The mix-design of a two-component grout is claiming for different requirements depending
 95 on the job site characteristics and geological formation; however, the typical mix-design in
 96 a m^3 system for a two-component grout consists in general by cement (280-450 kg),
 97 bentonite (30-60 kg), water (730-860 kg), retarder (3-5 kg) and accelerator (60-80 kg),
 98 normally sodium silicate. The accelerator (“B” component) is generally added just before the
 99 pumping phase of the mix of water, bentonite, retarder and cement (“A” component).
 100 Simultaneous backfilling with two-component grouts, in comparison with the mortar type
 101 grouts, keeps in general lower settlements during TBM excavation (Hirata, 1989). Keeping
 102 in mind the importance of the two-component grout during tunneling advancement, it must
 103 be recognized that not many works deal with this material both experimentally and
 104 numerically. It is well-known that the mechanical properties of the two-component grout
 105 change based on the mix-design type (e.g. Flores, 2015; Todaro et al., 2019).
 106 Oh and Ziegler (2014), Shah et al. (2018), Ochmański et al. (2018) and more recently
 107 Ochmański et al. (2021) performed a numerical analysis regarding the effects of the two-
 108 component grout on the tunnel settlement. However, the creep behavior of two-component
 109 grouts has not be analyzed in details so far. In this paper, a mix-design of a two-component
 110 grout has been tested by determining the Unconfined Compressive Strength (UCS) and the

111 creep strain evolution at varying curing ages. From the analysis of the laboratory results it
112 was possible to understand the behavior of this material with particular attention to the
113 deformability and strength values during a loading phase and the analogous response to
114 long term loading, by maintaining different loads acting on the specimen. It was possible to
115 describe the development of deformations over time of the two-component material
116 subjected to different load entities related to the UCS. From the analysis of the laboratory
117 results it was possible to describe a behavioral model of the creep phase of the two-
118 component material and also to evaluate the effects of the evolution of deformations over
119 time on the behavior of the segmental lining and on the displacements of the tunnel wall.
120 The analysis of a real case of a tunnel excavated in Northern Italy in a weakly cohesive
121 material allowed to verify the effects of the creep of the two-component material on the
122 behavior of the support system, arriving at evaluating the reduction over time of the loads
123 applied to the segmental lining (stress relief) and the increase in the radial displacement of
124 the tunnel wall at the end of the creep phase.

125 **General creep models**

126 Due to the strains increase with time in tunnelling, creep can be an important phenomenon,
127 especially for very soft or heavily fractured rocks under significant in-situ stresses (Yu, 1998;
128 Dusseault and Fordham, 1993), for rocks of argillaceous nature (Barla, 2011) or also when
129 a combination of applied stresses and material properties, some specific geological
130 conditions, and/or a groundwater flow exist. For rocks containing clay, the phenomenon,
131 associated with water migration (or clay platelets orientation), could be considered as a
132 consolidation typology (Goodman, 1980).

133 When a specimen is subjected to a constant maintained load in unconfined compression in
134 the microfracturing range, the specimen will continue to deform after initial application of the
135 load (Hardy et al., 1969). Normally creep strain are not fully recovered; therefore, large

136 plastic deformations take place (Dusseault and Fordham, 1993). Time dependent strain is
137 much higher in weak rocks and evaporites than in stiffer rocks, but the typical shape of the
138 strain trend is similar. Three reference types of deformation can be observed following the
139 strain trend under a maintained stress (Farmer and Gilbert, 1981):

140 a) level of applied load is maintained above a critical microcrack development level, then
141 unstable fractures will accelerate creep strains and quickly leading to specimen
142 failure;

143 b) level of stress is well below the critical microcrack development level, there will be a
144 limited spreading of fractures with an exponentially decaying of the creep strain rate
145 and stable conditions (no failure);

146 c) the intermediate zone represents a meta-stable condition, where cracks propagation
147 can occur leaving stable microfractures and reaching unstable conditions with crack
148 acceleration and failure. This can happen also with staged conditions of loading
149 (Figure 2, Oggeri, unpublished data).

150 Figure 2 shows an example of evaporitic rock presented for comparison with different
151 behaviour with deformation under constant loading. Trend of the curves, threshold levels for
152 both stress and strain and final control of specimen integrity can differ during testing.
153 Therefore, a dedicated experimental approach is deemed necessary for any new material.
154 Specimen a) and b) are coming from the same deposit, but even small differences in texture
155 and grain size of particles are influencing the test results.

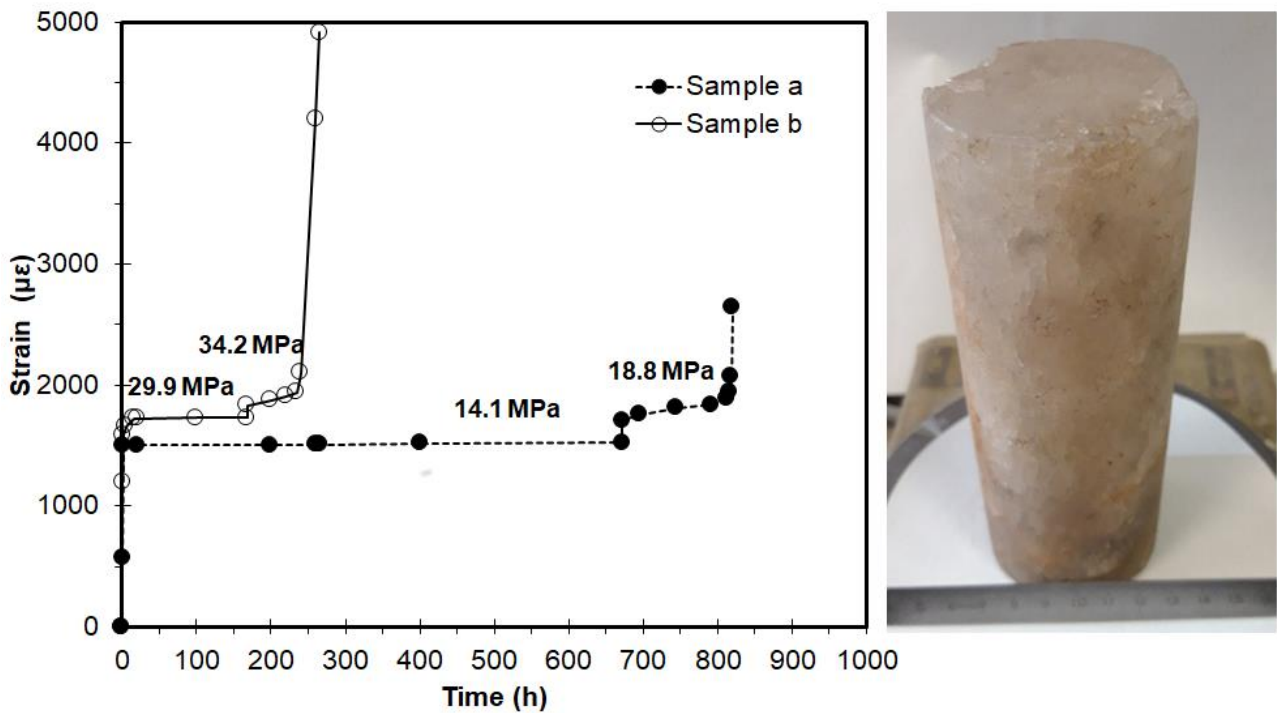

156

157 **Fig. 2: Two examples of creep with a staged loading on evaporitic rocks. Specimen a)**
 158 **is entirely made of salt, with microcrystals from millimetric to centimetric size (see**
 159 **figure on the right); after an initial stable load at 14.1 MPa, failure is reached with a**
 160 **step at 18.8 MPa. Specimen b) is a fine-grained salt including elements of marl; after**
 161 **an initial load at 29.9 MPa, failure is reached with a step at 34.2 MPa.**

162 Many models of creep and testing procedures have been carried out after the extended
 163 research by Griggs (1939) and refinements after Lama and Vutukuri (1978). Alternative
 164 approaches have been developed by Price and Farmer (1981).

165 In tunneling, many models are used to describe the creep of rocks and sprayed concrete,
 166 e.g. rheological models (Jaeger and Cook, 1979), Kelvin model (Neville et al. 1983; Jaeger
 167 and Cook, 1979; Rokahr and Lux 1987), Burgers model (Yin 1996), viscoplastic model
 168 (Thomas 2009). In sprayed concrete creep is significantly higher at an early stage of load
 169 as the strength of sprayed concrete is lower, as found by Huber (1991), who observed that
 170 a sample loaded at 8 days creeps by 25% more than a similar sample loaded at 28 days.

171 However, it must be kept in mind that some accelerators increase the early strengths
172 (Melbye 1994) therefore creep after 24 or 48 h is close to that at greater ages (Kuwajima
173 1999). Besides, studies have been carried out for the assessment of creep reaction of grout
174 for rockbolts (Van der Schyff, 2007), or for a new method for designing the grout mix based
175 on the induced shear stress rather than on the compressive strength (Orumchi and Mojallal,
176 2017); other contributions have been given for the creep behavior of a grouted sand
177 (Delfosse-Ribey et al., 2006): depending on the nature of the grout, the grouted sand has
178 exhibited creep strains of different degrees; moreover, similarities can be found for both
179 creep behavior and fatigue behavior as found trend curves have showed similar shapes.

180 Arnau et al. (2011) provided analyses in order to study the backfill grout behavior and its
181 influence on the longitudinal response of the lining in plane strain. Three different grout
182 moduli of elasticity were used in the analysis for each different ground condition. An
183 assessment of the influence of grout shrinkage was also performed by assuming a value of
184 0.05 mm/m according to favorable curing conditions. The results showed that the modulus
185 of elasticity of the grout was not presenting a significant influence on the lining axial stress,
186 while tensile cracking for very stiff grouts could occur and that the lining creep and the grout
187 shrinkage were not significantly influencing the grout tensile stress for general tunnel
188 conditions. Backfill grout cracking was unable to influence negatively the radial structural
189 capacity of the segmental lining, while caused a reduction in the water-tightness of the lining.
190 It must be pointed out that in some cases (hydraulic tunnels) there is a significant internal
191 pressure in the tunnel which forces the backfilling mortar to play a crucial role of contact
192 between lining and rock mass. Besides, over time cracks lead to a loss of confinement of
193 the same backfilling material which, consequently, significantly reduces its mechanical
194 characteristics which could also lead to significant alignment/structural problems in the
195 lining.

196 As final comment, the annulus grout material may remind of clay (bentonite)-cement slurries
197 for diaphragm wall applications (e.g. Cardu and Oreste, 2012; Spagnoli et al., 2016).
198 Although creep behavior may be studied, operative care is focused mainly on integrity, low
199 permeability performances, self-sealing properties, as well local displacement of the
200 structure *in situ*. For the annulus grout loading values are changing together with curing, and
201 stiffness and time performance is governing the interaction between a soft material (usually
202 the ground) and a very stiff material (the concrete segments).

203 **Laboratory creep behavior of the two-component grout**

204 The tested two-component mix-design adopted for this experimental campaign was based
205 on the following parts:

- 206 • Part A: water 800 g, bentonite 35 g, cement (CEM I 52.5) 350 g, retarder 17.5 g
207 (solution contains 20% solid therefore retarder dosage by weight of cement is 1%);
- 208 • Part B: water glass (sodium silicate) 85 g.

209 Part B is added at the end of mixing of the mentioned components as it reacts quickly by
210 producing a viscous grout (water glass represents about 7% of added weight to the initial
211 mix). Grout has been prepared starting from the bentonite hydration (duration at least 48
212 hours), then the slurry has been maintained for another 24 hours at low stirring. The mixing
213 with retarder and cement has been arranged directly inside the casing of the specimens, by
214 manual dispersion; finally, water glass catalyst has been injected into the fluid grout and a
215 high-speed rotating mixer (up to 8000 rpm) has been used during this phase. Every
216 specimen has been prepared by respecting the mass percentages provided for the standard
217 mix; weight of the components has been determined by means of 0.01 g precision scale.

218 Fast rotation of mixer has allowed to disperse the catalyst and homogenize the grout inside
219 the casing. Then, the casings containing the specimens have been recovered in a box for

220 curing in water. Curing procedure has been selected following three different timelines for
221 testing: 24 h; 7 days; 28 days. Preparation of the specimen requires great care and repeated
222 preliminary attempts were done in order to obtain a suitable material. Temperature during
223 the tests has been kept constant at 19-21°C.

224 UCS has been carried out in a Belladonna mechanical press for soils, equipped with
225 bidirectional displacement rate control device. Transducers used to measure load and
226 vertical displacement have been respectively a full bridge load cell (CCT model, full scale 5
227 kN and precision of 1 N) and LVDT devices (HBM models, precision 0.001 mm). Vertical
228 displacements have been measured following the relative movement of the base of the
229 specimen. Advancing rate has been adapted in the range of 0.15 ÷ 0.45 mm/min and
230 suitable results have been obtained for the range 0.30 ÷ 0.45 mm/min. This selection is a
231 good compromise to avoid creep behavior (excess of lateral swelling) or sudden failure
232 (vertical cracks). Specimen diameter has been selected as 46.5 mm.

233 Creep testing has been performed by using a standard mechanical oedometer (Belladonna
234 equipment) (Fig. 3), with settings to host the cell (a graduated plastic cylinder) with water
235 and the specimen. The host cell was made of stiff and transparent polypropylene and the
236 contact base with the specimen has been provided of a flat stainless-steel disk to avoid any
237 local deformation. A similar arrangement was already successfully used by Delfosse-Ribey
238 et al. (2006).

239 The adaptation of a classical Bishop lever oedometer has been done in order to fit the
240 expected strength level of the grout, if compared with typical properties of rock material
241 tested for creep (salt, coal, gypsum etc.). This equipment permits:

- 242 • to work from very low to medium stress levels;
- 243 • to provide a perfect vertical alignment of caps at the extremities of the specimen;
- 244 • to provide a full recovery of mechanical gaps during assembling of specimens;

- 245 • an easy water saturation control in open cells and drainage filters at contact with the
246 specimens;
- 247 • to continuously read the vertical displacement versus time; easy and direct check of
248 macroscopic cracking growth or lateral bulging.

249 The procedure for testing is following some steps: 1) preparation of the specimen with
250 selected mix and curing time in submerged conditions; 2) weighting and photos of the
251 specimen; 3) assembling inside the cell and filling of the cell with water; 4) mechanical gap
252 recovery of the displacements of the apparatus; 5) application of the selected load on the
253 lever arm in order to reach the selected stress level, according to previous experience
254 gained in uniaxial compression tests; 6) measurement of vertical displacement versus time;
255 7) detection of the trend and completion of the testing duration after reaching either a failure
256 (stable failure when residual bearing capacity is evident; unstable failure when specimen
257 start to yield and collapse) or a constant settlement; 8) removal of load and measurement
258 of eventual elastic strain recovery; 9) removal of the specimen, taking photos to verify the
259 crack pattern and weighting for moisture content.



261 **Fig. 3 Left: Twin cells adapted in the oedometer frame, where specimens are kept**
262 **submerged during constant load application and vertical settlement of the base is**
263 **continuously measured. Right: detail of a specimen inside a testing cell.**

264 It is important to specify that standard test procedure for one-dimensional consolidation
265 properties of soils have been adapted in order to respect the fact that grout is curing during
266 testing: this is not the case for natural minerals such as salt or gypsum. After some practical
267 preliminary tests, repeatability and representativity have been observed for loading periods
268 of no more than one week after 24 hours of initial curing and of no more than four weeks
269 after 7 days and 28 days from curing beginning. Specimens have been maintained saturated
270 during cycles to avoid cracking, and displacements have been measured by means of
271 potentiometric transducers with precision of 0.01 mm. Fig. 4 shows the specimens used for
272 the tests. Quality in terms of homogeneity and geometry was considered acceptable.



273

274 **Fig. 4 Example of standard specimens prepared and obtained for UCS and creep**
275 **testing. The grain size of the cured grout specimens appears regular and**
276 **homogeneous, without veins or lenses of different consistency.**

277 *UCS results*

278 The main results after unconfined compression testing are reported in Table 1. Strength is
279 considered as the maximum value of stress obtained, for the great majority of cases, at yield
280 at the end of the elastic domain. Deformability values are indexed as secant moduli, E_s , at
281 25%, 50% and 75% of the elastic domain and as tangential values, E_t , at 50% of the elastic
282 domain. In Fig. 5 there is a representative sequence of vertical stress – vertical strain curves
283 for different curing ages. The observed UCS values are rated similar than expected if
284 compared with other available results on this grout type (see Oggeri et al., 2021). Vertical
285 stress versus vertical strain is reliable both in the elastic and in the post peak field. A clear
286 yielding and softening behavior have been observed, with some subvertical and inclined
287 prevailing cracks. In some cases, a pseudo-conical shape at failure has been observed at
288 the extremities of the specimen, thus respecting the ideal Mohr-Coulomb strength criterion
289 (Fig. 6).

290

291 Tab. 1 Summary of specimen data for the UCS tests.

24 h curing	Diameter (mm)	Height (mm)	Weight (g)	Apparent unit weight (g/cm³)	UCS (kPa)	E_s 25% (MPa)	E_s 50% (MPa)	E_s 75% (MPa)	E_t 50% (MPa)
n.1	46.5	85	187.6	1.299	480	6.5	9.7	11.5	23.1
n.2	46.5	84.4	185.0	1.291	215	5.6	8.7	10.2	17.9
n.3	46.2	85.2	186.2	1.304	350	9	12.3	16.5	26.2
n.4	46.5	84.9	186.3	1.292	320	8.1	10.1	13.3	24.7
7 days curing	Diameter (mm)	Height (mm)	Weight (g)	Apparent unit weight (g/cm³)	UCS (kPa)	E_s 25% (MPa)	E_s 50% (MPa)	E_s 75% (MPa)	E_t 50% (MPa)
n.1	46.5	86	190.1	1.302	1270	25.8	34.1	42.6	78.1
n.2	46.5	86	192.0	1.314	1110	17.5	26.5	32.3	73.8
n.3	46.5	83	186.3	1.322	760	51.2	63	74.7	76.41
n.4	46.5	84	190.1	1.332	1150	38.5	50	55.4	117.8
n.5	46.5	89	192.6	1.274	990	33.3	43.2	54.6	109.9
28 days curing	Diameter (mm)	Height (mm)	Weight (g)	Apparent unit weight (g/cm³)	UCS (kPa)	E_s 25% (MPa)	E_s 50% (MPa)	E_s 75% (MPa)	E_t 50% (MPa)
n.1	46.5	83	183.3	1.300	1290	37.8	44.8	54.9	109.4
n.2	46.5	83	185.5	1.316	1110	20.4	26.2	32.7	63.3
n.3	46.5	84	188.6	1.322	1290	33.3	44	59.6	108.7
n.4	46.5	86	192.1	1.315	1400	30.1	43.1	57.1	111.2

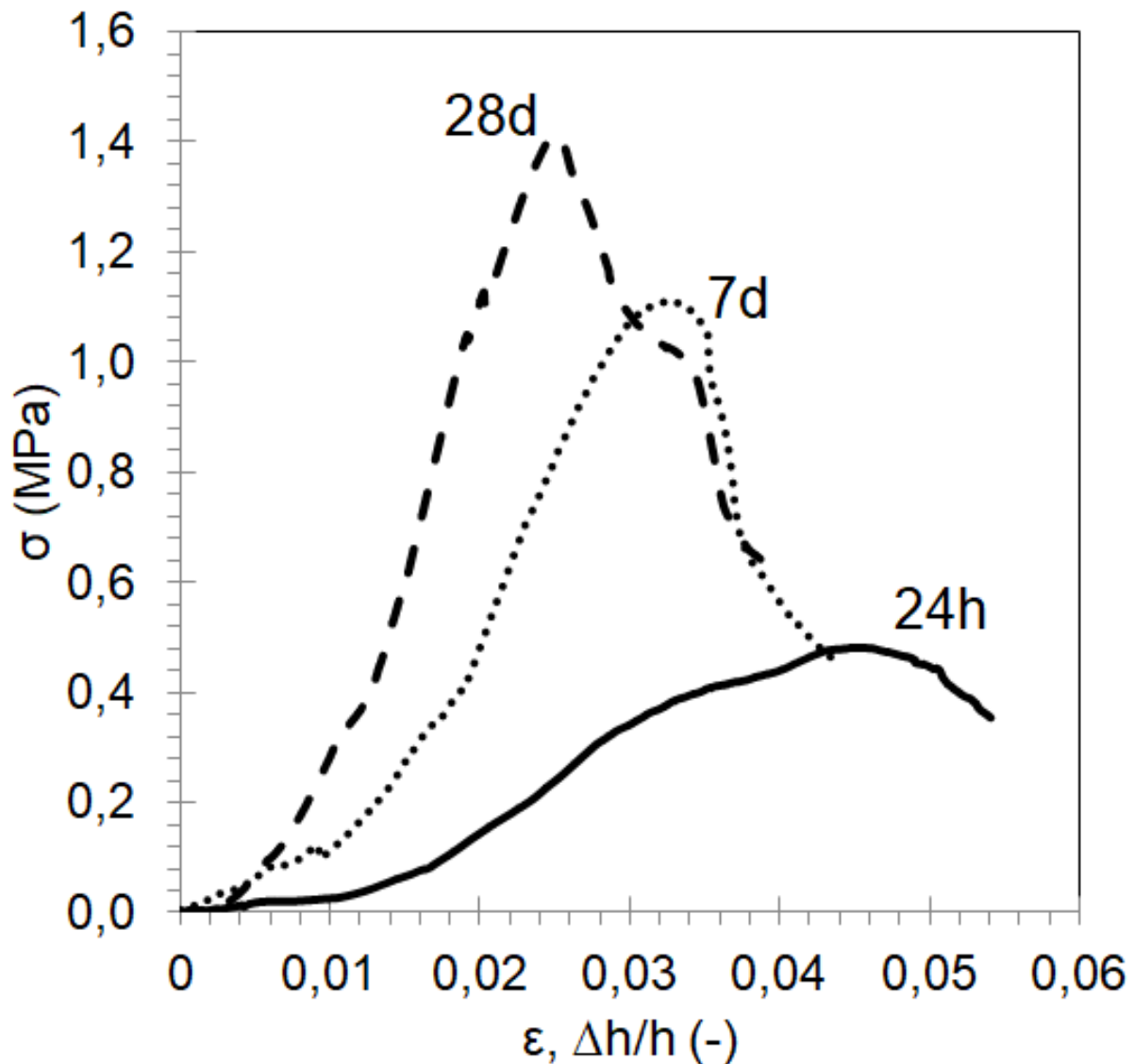

292

293 **Fig. 5. Examples of vertical stress – vertical strain curves for grout specimens at**
 294 **different curing age (at 24 hours, 7 days and 28 days from curing beginning,**
 295 **respectively), during a uniaxial compressive test. Along the vertical axis applied**
 296 **stress σ in MPa is reported, along horizontal axis induced vertical strain in ϵ (ratio of**
 297 **the vertical displacement on the sample height) is reported. Strain softening after the**
 298 **stress peak is more evident for short age curing specimens.**

299

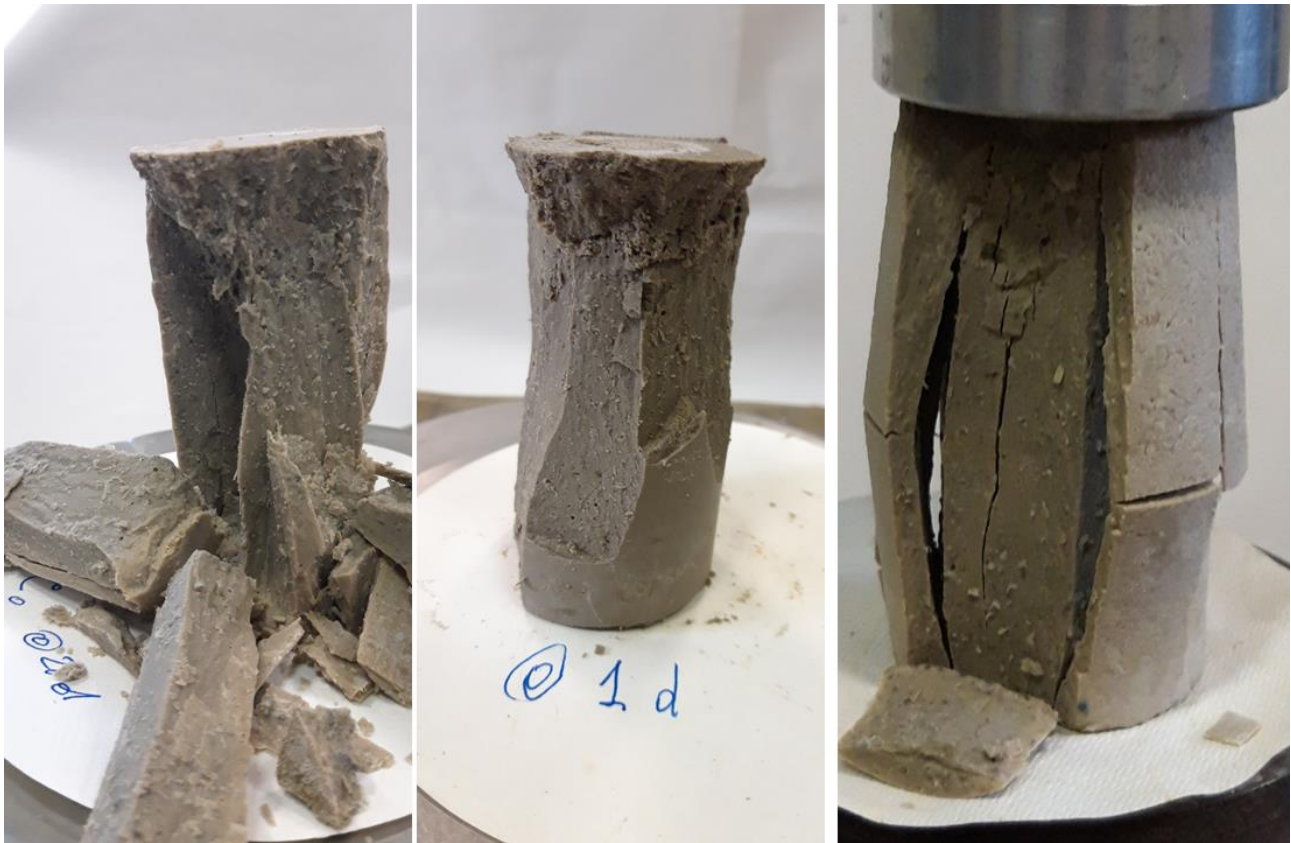

300

301 **Fig. 6. Different failure modes for specimens after unconfined compression testing.**
302 **The formation of conical shaped bodies is clearly visible at left and in the middle. On**
303 **the right, the radial expansion has prevailed with symmetrical formation of vertical**
304 **slabs.**

305 *Creep tests results*

306 Constant loading testing has been carried out on several specimens, and the selection of
307 regular behavior has been reported after exclusion of not homogeneous materials. In Table
308 2 the evidence of 11 tests is reported, with geometrical data and the applied vertical loads,
309 both effective and as a percentage of the reference value obtained from the compression
310 tests. The UCS has been determined in advance in order to properly assign a reasonable
311 ratio of the applied constant load, just because this ratio triggers the passage between a
312 stable and an unstable behavior.

313

314 **Tab. 2. Summary of specimen data for constant loading (creep) tests. Last column shows the load percentage referred to a**
 315 **representative value of UCS for the same type of grout and curing age.**

24 h curing	diameter (mm)	height (mm)	weight (g)	apparent unit weight (g/cm³)	σ creep (kPa)	σ creep (as % UCS)
n.1 creep	46.2	85.3	187.1	1.308	290	75
n.2 creep	46.5	85.2	186.2	1.287	230	60
n.3 creep	46.5	85.8	187.2	1.285	175	45
n.4 creep	46.5	87.6	189.2	1.270	115	30
7 days curing	diameter (mm)	height (mm)	weight (g)	apparent unit weight (g/cm³)	σ creep (kPa)	σ creep (as % UCS)
n.1 creep	46.5	87.0	192.0	1.300	700	66
n.2 creep	46.5	85.6	187.9	1.293	580	55
n.3 creep	46.5	93.8	203.8	1.279	460	45
n.4 creep	46.5	85.7	188.5	1.295	350	33
28 days curing	diameter (mm)	height (mm)	weight (g)	apparent unit weight (g/cm³)	σ creep (kPa)	σ creep (as % UCS)
n.1 creep	46.5	86.0	192.2	1.316	930	75
n.2 creep	46.5	85.1	189.4	1.312	700	55
n.3 creep	46.5	84.2	186.0	1.304	460	35

317 In Fig. 7 the net settlement versus time trend is reported, for the three selected curing
318 periods, respectively 1 day (A), 7 days (B) and 28 days (C). The tests have shown,
319 depending on the applied load magnitude:

- 320 • at 1 day of curing: a stable behavior for 2 specimens, a stable failure for 1 specimen,
321 an unstable failure for 1 specimen;
- 322 • at 7 days of curing: a stable behavior for 1 specimen, a stable failure for 1 specimen,
323 and unstable failure for 2 specimens;
- 324 • at 28 days of curing: a stable behavior for 2 specimens, an unstable failure for 1
325 specimen.

326 Fig. 8 shows some representative effects after the end of the creep test. It is possible to
327 observe how the grout can respond to a constant loading. It is necessary to remind that for
328 1 days and 7 days curing ages grout is still strengthening, even if failures occur due to
329 loading. Only for long term-curing, i.e. 28 days, it fair to state that full mechanical properties
330 of grout have been reached.

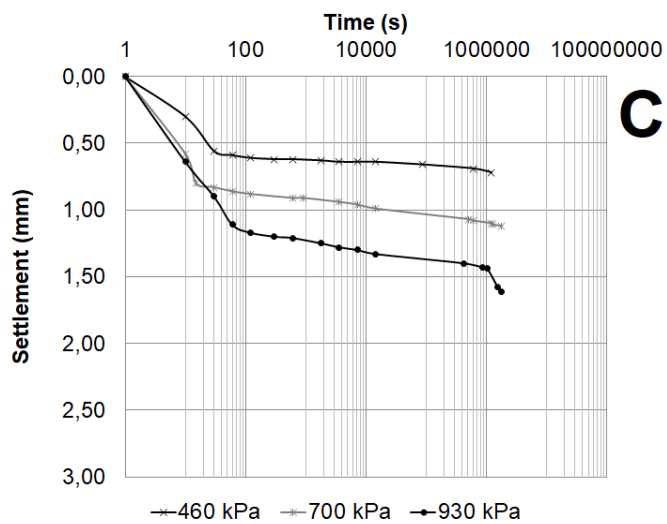
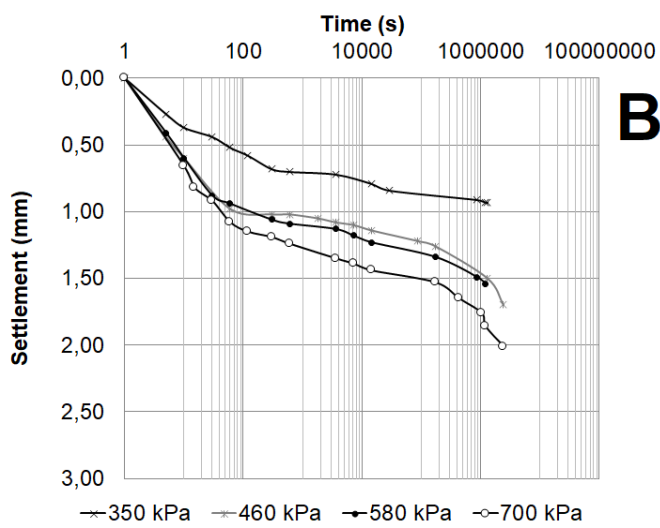
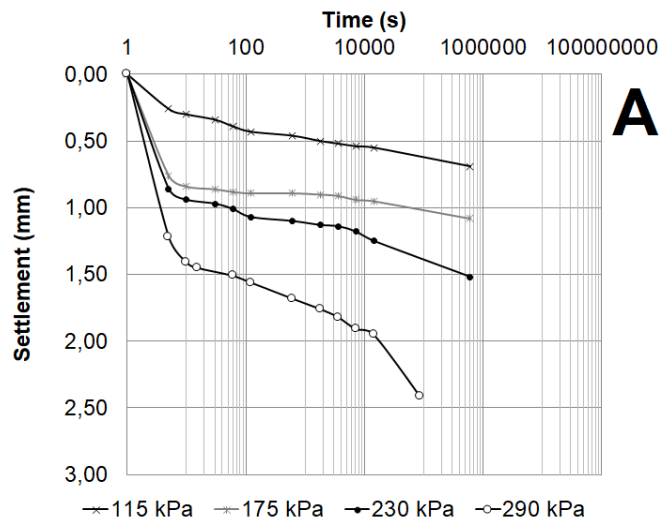

331

332 **Fig. 7 Net settlement versus time are reported, for the three selected curing periods,**
 333 **respectively 1 day (graph A with 2 stable behavior, 1 stable failure, 1 unstable failure);**

334 7 days (graph B with 1 stable behavior, 1 stable failure, 2 unstable failure); 28 days
335 (graph C with 2 stable behavior and 1 unstable failure).

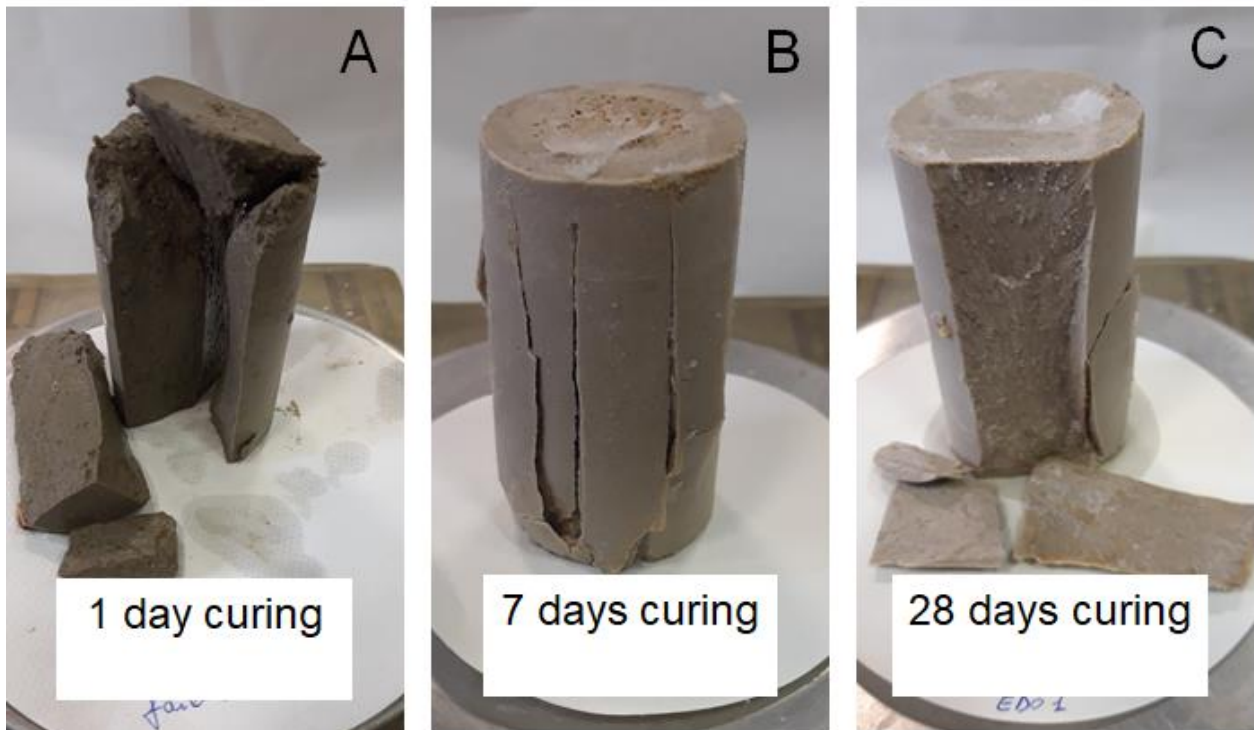

336

337 **Fig. 8. Different failure modes for specimens after creep (constant load). A) de-**
338 **assembled specimen, failure with conical end shape, curing 1 day; B) failure with axial**
339 **symmetry for lateral expansion, 7 days curing; C) failure with conical end shape, 28**
340 **days curing.**

341 **Comments of laboratory results**

342 The available data and the observed behavior during the standard compression test and
343 during compression tests with constant loads (creep tests), for this mix-design, can allow to
344 put in evidence some features:

- 345 • the mixing procedure carried directly inside the casing has determined a little increase
346 in the unit weight referred to the test results reported in a previous campaign, thanks

347 to the reduction of the weak material removal from the end of the specimen during
348 preparation;

- 349 • there is a general increase in UCS strength and in elastic moduli due to the previous
350 point;
- 351 • all specimens have shown a post peak behavior, with wider strain softening for
352 shorter curing ages;
- 353 • in some cases, a clear evidence of conical shaped ends at failure of the specimens
354 has been observed, both in compression tests and during creep tests;
- 355 • long term strains do not reach an ultimate value, even when in stable loading; this
356 happens in particular at 1 day and 7 days of curing, less for 28 days of curing. The
357 balance between the maintained load and residual strengthening appears to be
358 reasonably the cause for the observed trend;
- 359 • strain creep diagrams show one half of final value occur in the initial 2 minutes; there
360 is an initial link with expected values after compression testing, then stiffness changes
361 as a consequence of induced damage. The load in creep tests, even if less than UCS,
362 is anyway applied instantly;
- 363 • in creep testing, for some specimens, failure has been observed as a progressive
364 trend towards unstable crack propagation;
- 365 • no absolute and unique link between measured settlements in creep and the
366 correspondent modulus of deformability in the compression test has been found;
367 however satisfactory correlations exist between ΔH_{final} in stable creep zones and E_s
368 75% from compression tests for 1 day and 28 days of curing; in a similar way,
369 correlation exists between $\Delta H_{primary}$ in creep and E_s 75% from compression tests for 7
370 days of curing;
- 371 • the deformative process results to be different for short grout curing age (1 day)
372 respect to 7 or 28 days of curing age;

373 • Although temperature has an effect on creep behavior for both rocks (Li et al., 2019)
374 and concrete (e.g. Geymayer, 1970) accelerating creep, its effects are beyond the
375 scope of this research.

376 The trend of deformations over time after 7 and 28 days of curing is interesting to evaluate
377 in order to study the effect of the creep of the two-component material on the behavior of
378 the support system.

379 In particular, after 7 days of curing it is useful to refer to the curve obtained by applying an
380 axial load equal to 33% of the failure stress (UCS) of the material (Fig. 9); this load did not
381 cause the material to fail and a final stabilization of deformations was observed. For applied
382 loads equal to 45% of UCS or higher (55% and 66%), on the other hand, the failure of the
383 material was achieved after a creep phase.

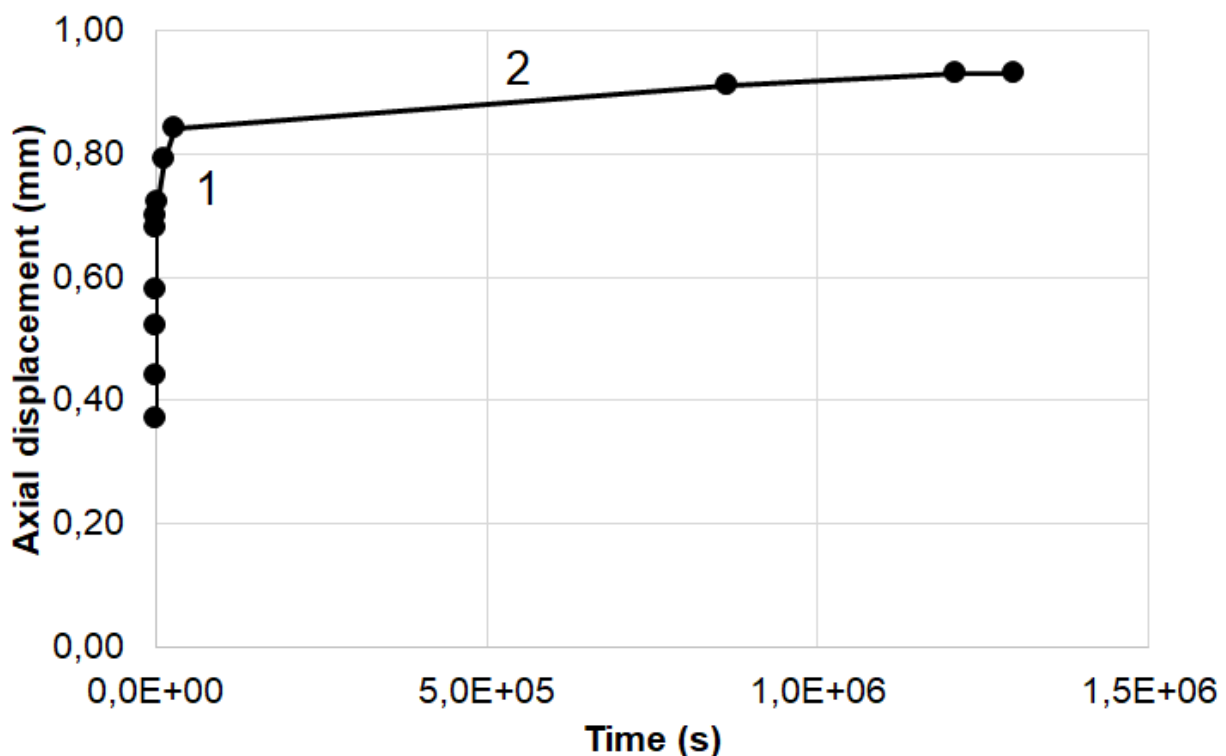

384
385 **Fig. 9. Trend of deformations over time in a sample of two-component material cured**
386 **for 7 days and subjected to an axial load equal to 33% of UCS. After the application**
387 **of the load, there is a significant increase in displacements in the first 10 minutes,**

388 **after which the displacements grow with a markedly bi-linear trend (zones 1 and 2 in**
389 **the graph) until stabilization is reached after about 14 days from loading.**

390 From the analysis of the figure it can be seen that the immediate displacement (δ_{inst}) upon
391 application of the load is 0.37 mm. In the first 10 minutes there is a significant increase in
392 the displacements until reaching a double value of δ_{inst} , after which the displacements
393 increase with a markedly bi-linear trend until stabilization is reached after about 14 days
394 from loading: in the first linear section, the displacement changes from $2.00 \cdot \delta_{inst}$ to $2.25 \cdot \delta_{inst}$
395 after 8 hours from the application of the load; in the second linear section it reaches a
396 displacement of $2.50 \cdot \delta_{inst}$ after 14 days from the application of the load. The expressions
397 that describe the trend of the displacements over time in the two linear sections are shown
398 below:

$$399 \quad \delta = [2.00 + 0.032 \cdot (t - 1/6)] \cdot \delta_{inst} \quad (t \text{ in hours}), \text{ for } t \text{ ranging between } 1/6 \text{ hours and } 8 \\ 400 \text{ hours} \quad (1)$$

$$401 \quad \delta = [2.25 + 0.018 \cdot (t - 1/3)] \cdot \delta_{inst} \quad (t \text{ in days}), \text{ for } t \text{ ranging between } 1/3 \text{ days and } 14 \text{ days} \\ 402 \quad (2)$$

403 After 28 days of curing, the specimen on which a load equal to 75% of the UCS value was
404 applied reached failure after the creep phase. While for loads equal to 35% and 55% of
405 UCS, there was no failure of the specimen subjected to the creep test. More specifically, for
406 the load equal to 35% of UCS we note the same bi-linear trend observed for the case
407 referred to the 7-day curing, with a value of δ_{inst} equal to 0.30 mm. While for the load equal
408 to 55% there is also a bi-linear trend but with the following characteristics: even now in the
409 first 10 minutes there is a significant increase in displacements until reaching a value of
410 $1.5 \cdot \delta_{inst}$; after which the displacements increase up to $1.75 \cdot \delta_{inst}$ after 8 hours from the
411 application of the load and in a second stretch up to the final stabilization at 14 days from
412 the application of the load with a final displacement value equal to $2 \cdot \delta_{inst}$.

413 From a detailed analysis of the results of the creep tests, therefore, the following can be
414 noted:

- 415 • the maximum percentage of the load with respect to UCS that would allow to avoid
416 the failure of the specimen in the long term goes from about 40 for 1 week of curing
417 of the material to about 70 for 4 weeks of curing of the specimen;
- 418 • the trend of deformations over time follows a bi-linear law after the first 10 minutes of
419 loading; a first stretch is between 10 minutes and 8 hours from the application of the
420 load, the second stretch from 8 hours to 14 days from the application of the load;
- 421 • the curing age of the specimen does not seem to alter the deformation curve over
422 time; a certain effect on this curve is given by the applied load, evaluated as a
423 percentage of the UCS value;
- 424 • the deformation increases according to two linear sections and the total value of the
425 creep strain is constant and equal to one half of the immediate deformation detected
426 on the specimen upon application of the load, regardless of the curing age of the
427 specimen and the percentage value of the applied load;
- 428 • in the first 10 minutes from the application of the load the deformations grow rapidly
429 until reaching 2 times the immediate deformation ($2 \cdot \delta_{inst}$) for percentages of the load
430 equal to about 35% of UCS and 1.5 times the immediate deformation ($1.5 \cdot \delta_{inst}$) for
431 percentages of the load equal to about 55% of UCS.

432 Immediate deformation therefore has a significant importance in understanding the
433 phenomenon of creep because it influences the deformation levels that develop in the
434 material over time. From the results obtained in the laboratory tests (uniaxial compression
435 and creep), it can be seen how the initial deformation can be estimated with a good
436 approximation by adopting the tangent elastic modulus determined in the uniaxial
437 compression tests, associated with the stress value equal to the applied load in the creep

438 test. Ultimately, if the applied load is equal to 35% of UCS, the immediate deformation of
439 the specimen ε_{inst} will be defined by the following relationship:

$$440 \quad \varepsilon_{inst} = \frac{0.35 \cdot UCS}{E_{t,35\%}} \quad (3)$$

441 where:

442 UCS is the monoaxial compressive strength of the two-component material measured for a
443 specific curing age;

444 $E_{t,35\%}$ is the tangent modulus of elasticity measured at a stress level equal to 35% of UCS,
445 evaluated on a specimen of two-component material with a specific curing age, subject to
446 the uniaxial compression test.

447 **Analysis of the effects of creep on the tunnel support system**

448 The support system (segmental lining with the two-component material surrounding it) has
449 been studied in detail by Oreste et al. (2021). Using the convergence-confinement method,
450 it is possible to analyze the interaction between this support system and the tunnel wall. It
451 is a very widespread analytical method in the geomechanical field, such as the limit
452 equilibrium method (LEM) (Oreste, 2013), which combines the advantage of the simplicity
453 of the approach with the precision and reliability of the results.

454 Some simplifying hypotheses are necessary (Osgoui and Oreste, 2007; Oreste, 2009a;
455 2009b; Ranjbarnia et al., 2014; 2016; Spagnoli et al., 2016):

- 456 • circular and deep tunnel;
- 457 • initial stress state of hydrostatic type ($k_0 = 1$);
- 458 • homogeneous and isotropic soil or rock, with linear elastic behavior.

459 Specific and detailed studies of the behavior of the support system can be developed by
460 adopting three-dimensional numerical modeling (Do et al., 2014; 2015a; 2015b; Pelizza et
461 al., 2000).

462 In order to evaluate the load applied on the segmental lining and the deformation conditions
463 of the tunnel wall and of the segmental lining, it is necessary to intersect the convergence-
464 confinement curve with the reaction line of the support system (Fig. 10) (Oreste, 2003).

465 The convergence-confinement curve depends on the behavior of the ground at the tunnel
466 boundary: it relates the internal pressure applied on the tunnel wall to the radial
467 displacement of the tunnel wall towards the center of the tunnel (Brown et al., 1983; Panet,
468 1995). As the internal pressure decreases, the radial displacement increases, until it reaches
469 the maximum value when the internal pressure is zero.

470 The reaction line of the support system relates the pressure applied by the support system
471 to the variation of the displacement of the tunnel wall. This displacement also corresponds
472 to the displacement manifested by the support system on its outer edge, which comes into
473 contact with the tunnel wall. As the movement of the tunnel wall increases, the pressure
474 applied by the tunnel wall will increase.

475 There is an end equilibrium point between the tunnel and the support system which is given
476 by the intersection between the convergence-confinement curve and the reaction line of the
477 support system.

478

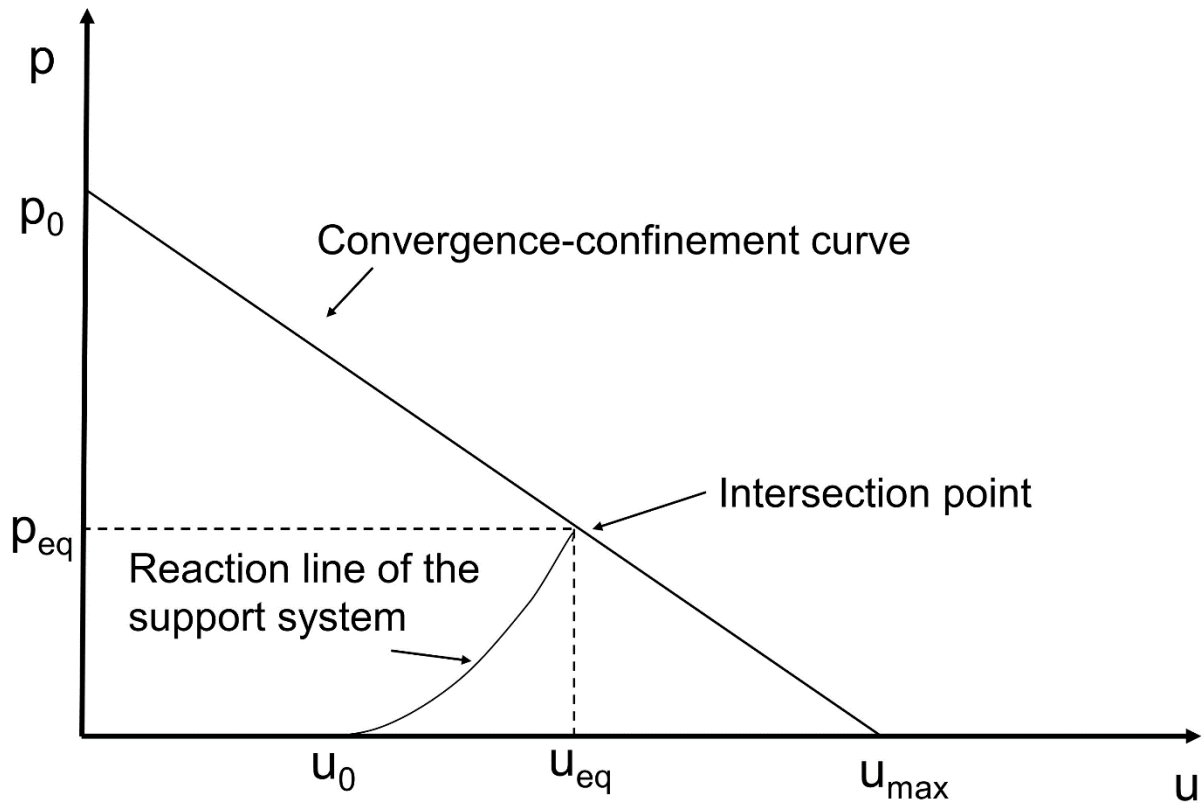

479

480 **Fig. 10** The intersection between the convergence-confinement curve of the tunnel
 481 **and the reaction line of the support system when this is composed of segmental lining**
 482 **and the two-component material around it (modified by Oreste et al., 2021). Legend:**
 483 **p : internal pressure applied to the tunnel wall; u : radial displacement of the tunnel**
 484 **wall; p_0 : lithostatic stress in the soil or rock at the depth of the tunnel; u_0 :**
 485 **displacement of the tunnel wall at the distance from the excavation face of the section**
 486 **where the support system is installed; $u_{max} = (1 + \nu_{gr}) \cdot p_0 \cdot R/E_{gr}$, where E_{gr} is the**
 487 **elastic modulus and ν_{gr} the Poisson's ratio of the ground (soil or rock) present around**
 488 **the tunnel; R is the tunnel radius; p_{eq} and u_{eq} : respectively the load applied on the**
 489 **support system and the radial displacement of the tunnel wall in the final condition**
 490 **of equilibrium, at the end of the process of loading the support system.**

491 An iterative procedure was developed to correctly describe the reaction line of the support
 492 system (Oreste et al., 2021). The curvilinear shape of the reaction line is due to the fact that

493 the two-component material matures during the loading of the support system. There will be
 494 two specific different stiffnesses of the support system: when the segmental lining is
 495 installed, the two-component material will have a very low initial stiffness (short curing age);
 496 at the end of the support loading process (when the excavation face has advanced to a
 497 distance of about $4 \cdot R$ from the study section), the stiffness of the two-component material
 498 reaches its maximum value. This different stiffness of the support system is reflected in the
 499 inclination of the curvilinear reaction line, which initially presents a lower tangent, until
 500 reaching the maximum inclination of the tangent line near the point of intersection with the
 501 convergence-confinement curve (end of the support system loading process).

502 The point of intersection is given by the values p_{eq} and u_{eq} respectively the load applied on
 503 the support system and the radial displacement of the tunnel wall in the final equilibrium
 504 condition. p_{eq} and u_{eq} can be obtained from the following expressions:

$$505 \quad u_{eq} = \frac{2 \cdot p_0 + u_0 \cdot (k_{sys,fin} + k_{sys,in})}{\frac{2 \cdot E_{gr}}{(1 + \nu_{gr}) \cdot R} + (k_{sys,fin} + k_{sys,in})} \quad (4)$$

$$506 \quad p_{eq} = p_0 - \frac{E_{gr}}{(1 + \nu_{gr}) \cdot R} \cdot u_{eq} \quad (5)$$

507 where:

508 $k_{sys,in}$ and $k_{sys,fin}$: stiffness of the support system at the beginning and at the end of the
 509 loading process; for the evaluation of the initial stiffness, reference is made to the curing age
 510 t_0 , necessary to resume the advancement of the TBM machine, which marks the start of
 511 loading of the lining; for the evaluation of the final stiffness, reference is made to the time
 512 (t_f) necessary for the excavation face to reach a distance of about $4 \cdot R$ from the studied
 513 section.

514 The overall stiffness of the support system is evaluated using the following equation (Oreste,
 515 2003; Oreste et al., 2021):

$$516 \quad k_{sys} = \frac{2 \cdot E_{fm} \cdot (1 - \nu_{fm}) \cdot R \cdot \left[\frac{E_{fm}}{(1 + \nu_{fm})} + (R - t_{fm}) \cdot k_{sl} \right]}{E_{fm} \cdot (1 - 2 \cdot \nu_{fm}) \cdot R^2 + (R - t_{fm})^2 \cdot \left[E_{fm} + (1 - 2 \cdot \nu_{fm}) \cdot (1 + \nu_{fm}) \cdot k_{sl} \cdot t_{fm} \cdot \left(1 + \frac{R}{(R - t_{fm})} \right) \right]} - \frac{E_{fm}}{(1 + \nu_{fm}) \cdot R} \quad (6)$$

517 where:

$$518 \quad k_{sl} = \frac{E_{sl}}{(1 + \nu_{sl})} \cdot \frac{(R - t_{fm})^2 - (R - t_{fm} - t_{sl})^2}{(1 - 2 \cdot \nu_{sl}) \cdot (R - t_{fm})^2 + (R - t_{fm} - t_{sl})^2} \cdot \frac{1}{(R - t_{fm})}$$

519 k_{sl} is the radial stiffness of the segmental lining;

520 E_{fm} and ν_{fm} are respectively the elastic modulus and the Poisson's ratio of the filling
521 material; E_{fm} varies over time with increasing curing age;

522 E_{sl} and ν_{sl} are respectively the elastic modulus and the Poisson's ratio of the segmental
523 lining;

524 t_{fm} and t_{sl} are respectively the thickness of the filling material and of the segmental lining.

525 To determine the k_{sys} values it is necessary to evaluate the elastic modulus of the filling
526 material E_{fm} . Imagining a progressive loading over time with a regular advancement of the
527 excavation face, the deformation process that develops in the filling material is the one that
528 refers to the first minutes of the creep tests.

529 Therefore, for the evaluation of the $k_{sys,in}$ reference must be made to the initial tangent
530 elastic modulus ($E_{fm} = E_{t,0\%}$ of the filling material). To determine $k_{sys,fin}$ a value of the elastic
531 modulus of the filling material must be adopted which depends on the stress level reached
532 inside it in the final equilibrium condition:

$$533 \quad E_{fm} \cong \frac{E_{t,\alpha}}{\omega} \quad (7)$$

534 where:

535 $E_{t,\alpha}$ is the tangent elastic modulus of the filling material associated with a percentage load
536 level α referred to UCS;

537 ω is a correction coefficient that takes into account the deformation increase that occurs in
538 the first 10 minutes of load in the creep test; it depends on the percentage α of the stress
539 level acting in the filling material with respect to the UCS strength, i.e. $\omega = 2.875 - 2.5 \cdot \alpha$.

540 Since the stress state induced in the filling material depends on the still unknown value of
541 p_{eq} , also in this case the value of E_{fm} must be adapted as a function of p_{eq} and u_{eq} , which
542 is obtained from the intersection of the two curves. Another iterative procedure is therefore
543 necessary.

544 The value of the maximum principal stress in the filling material can be obtained from the
545 following expression (Oreste et al., 2021):

$$546 \sigma_{1,max,fm} \cong \frac{u_{eq} \cdot \frac{E_{fm}(t_f) + E_{fm}(t_0)}{2 \cdot R} + (v_{fm} + v_{fm}^2) \cdot p_{eq}}{(1 - v_{fm}^2)} \quad (8)$$

547 where: $\sigma_{1,max,fm}$ is the maximum (circumferential) principal stress in the filling material.

548 The value α will be adapted until the values of p_{eq} , u_{eq} , $\sigma_{1,max,fm}$ and UCS are compatible
549 with each other. At that point, the reaction line of the support system can be correctly placed
550 in the graph and p_{eq} and u_{eq} evaluated.

551 Once the final configuration of the support system has been reached, it will be possible to
552 represent the effect of the creep on the bilinear tract of Fig. 9. On the basis of the
553 experimentation carried out and what was deduced in the previous paragraph, the overall
554 deformation increase due to the creep phenomenon can be estimated as half of the
555 immediate deformation, regardless of the curing age of the specimen and the value of the
556 applied load. It is therefore possible to derive the increase in deformation due to the creep
557 in the filling material from the following expression:

558
$$\varepsilon_{creep} = 0.5 \cdot \frac{\sigma_{1,max,fm}}{E_{t,\alpha}} \quad (9)$$

559 Since this deformation ε_{creep} is a circumferential deformation at the extrados of the filling
 560 material ring, it is possible to derive from it the increase in displacement Δu of the tunnel
 561 wall:

562
$$\Delta u = \varepsilon_{creep} \cdot R \quad (10)$$

563 Thanks to the knowledge of Δu it will be possible to represent the effect of the creep of the
 564 filling material on the graph of the convergence-confinement curve and evaluate the final
 565 displacement of the tunnel wall (Fig. 11).

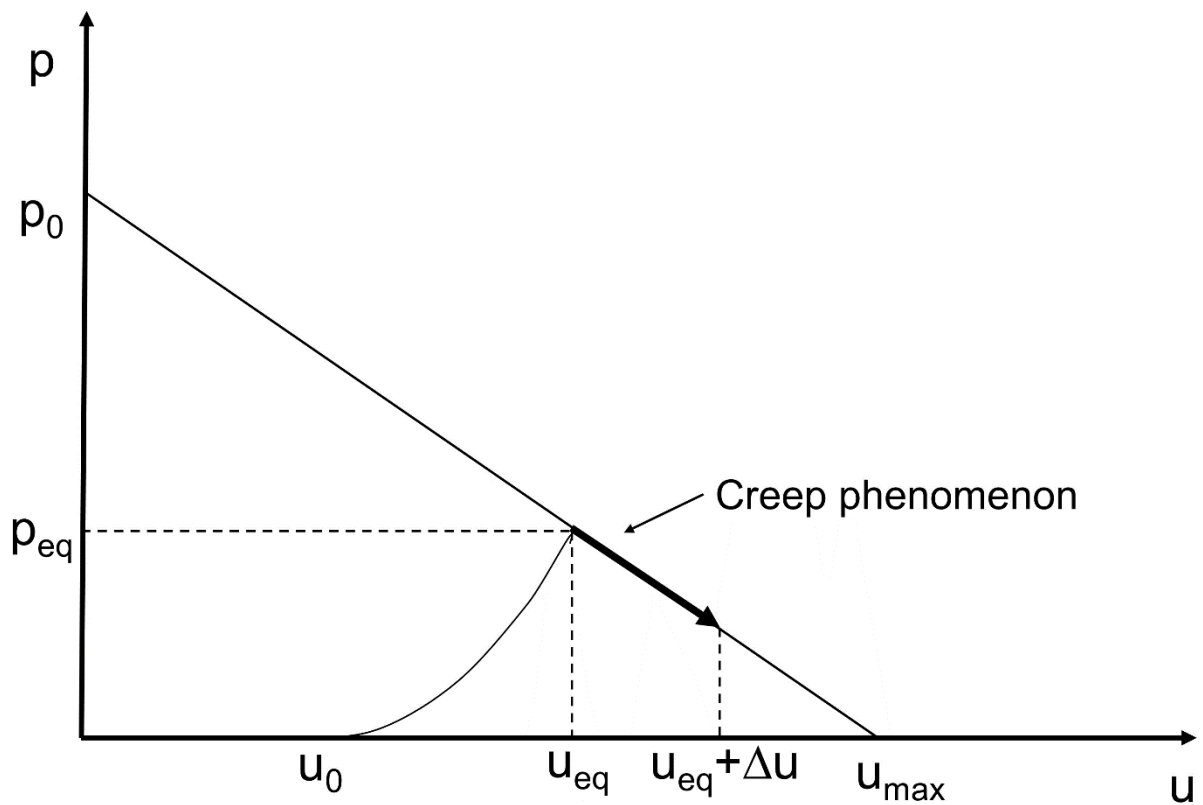

566

567 **Fig. 11. Representation of the creep phenomenon in the filling material once the final**
 568 **equilibrium point is reached at the end of the process of placing the support system**
 569 **in charge. Legend: Δu : increase in the radial displacement of the tunnel wall due to**
 570 **the creep of the filling material.**

571 The creep phenomenon therefore produces an increase in the displacement of the tunnel
572 wall, as well as a stress discharge of the segmental lining. Both results are fundamental for
573 tunnel design. The increase in the displacement of the tunnel wall is useful for evaluating
574 the subsidence of the soil surface in the long term. The stress relief of the segmental lining
575 allows to obtain the correct value of the safety factor of the support system in the long term.
576 Furthermore, the increase in the displacement of the tunnel wall as a result of the creep can
577 lead to values exceeding the maximum acceptable limits, such as to indicate an incorrect
578 functioning of the tunnel-support system. The final control of this displacement in the tunnel
579 design stage, therefore, is essential to avoid excessive values which could lead to high risks
580 of instability of the tunnel.

581 **Example of support system design considering the filling material creep phenomenon**

582 In defining the thickness of the filling material and also the thickness of the segmental lining,
583 it is necessary to consider the evolution over time of the mechanical characteristics of the
584 filling material (following its curing) and the creep phenomenon. In fact, the curing over time
585 and the creep phenomenon markedly characterize the two-component material and
586 influence the loading of the support system. The final load acting on the segmental lining,
587 therefore, depends on the thickness of the filling material and on the methods of loading the
588 support system. Oreste et al. (2021) have already demonstrated how the thickness of the
589 filling material, the downtime of the TBM machine after the construction of the support
590 system, the average speed of advancement of the TBM after the stop of the TBM are all
591 elements that influence the stress state in the filling material and the load acting on the
592 support system.

593 More specifically, the case of a tunnel with a length of 5 km and a diameter of 9.4 m,
594 excavated at a depth of about 70 m ($p_0 = 1.12$ MPa) in Northern Italy by a TBM machine
595 (EPB type) in a weakly cohesive soil having an elastic modulus E_{gr} of 150 MPa and a

596 Poisson's ratio ν_{gr} of 0.3 was analyzed in detail. The thickness adopted for the segmental
 597 lining (t_{sl}) was 0.35 m, the thickness of the filling material (t_{fm}) was 0.15 m. For the
 598 segmental lining concrete, an elastic modulus E_{sl} of 30,000 MPa and a Poisson's ratio ν_{sl}
 599 of 0.15 were assumed.

600 Considering a still stand for the construction of a new lining ring of 1 hour at a distance of
 601 2.5 m from the excavation face and an average advancement speed of the TBM v of 0.35
 602 m/h, the reaction line of the reported support system is shown in Figure 12 (modified after
 603 Oreste et al., 2021).

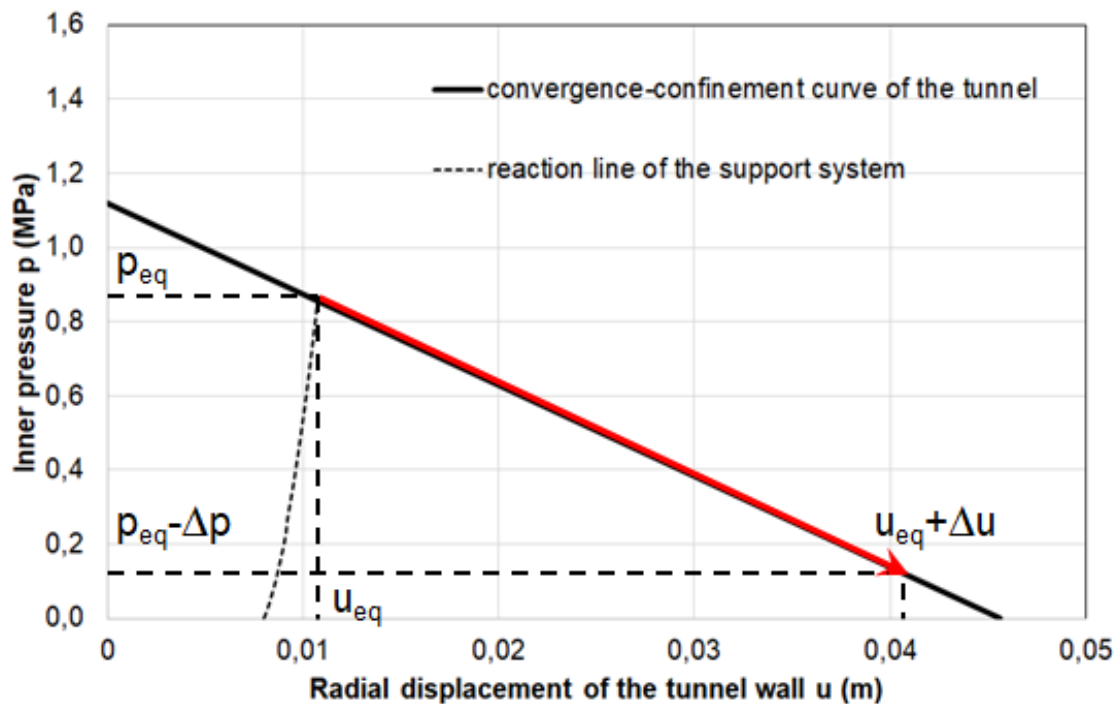

604

605 **Fig. 12. Convergence-confinement curve of the tunnel and reaction line of the support**
 606 **system in the examined case: tunnel with a diameter of 9.4 m at a depth of 70 m**
 607 **excavated in a weakly cohesive soil with an elastic modulus E_{gr} of 150 MPa. The**
 608 **support system consists of a 0.35 m thick segmental lining and a 0.15 m thick filling**
 609 **material ring. The red line represents the modification of the equilibrium point on the**

610 **convergence-confinement curve following the creep phenomenon in the filling**
611 **material.**

612 The pressure p_{eq} associated with the intersection point is 0.86 MPa and represents the load
613 acting on the support system at the end of the loading process, when the excavation face
614 reaches a distance of about $4 \cdot R$ from the study section of the support system. The
615 displacement u_{eq} is 10.7 mm: it is the final displacement of the tunnel wall at the end of the
616 loading process.

617 Using eq. 8 it is possible to determine $\sigma_{1,max,fm}$, the maximum (circumferential) principal
618 stress in the filling material at the end of the loading of the support system; a value of 0.92
619 MPa is obtained, which constitutes 31.6% of the strength of the material after about 48 h,
620 the average time necessary to reach the distance of $4 \cdot R$ from the investigated section.

621 From the experimental study developed and presented in the previous paragraphs, it was
622 possible to verify how the long-term strength of the two-component material is only a
623 percentage η of the UCS. In particular, the value of η depends on the days of curing of the
624 material:

$$625 \quad \eta \cong 0.3 + 0.0143 \cdot t_c \quad (11)$$

626 Where:

627 t_c is the curing age in days.

628 After two days of curing (48 h), therefore, η worth about 32.9%. This means, therefore, that
629 a maximum stress of 0.92 MPa (31.6% of the compressive strength UCS) is bearable by the
630 two-component material even in the long term without reaching failure. By maintaining its
631 integrity, the two-component material is able to effectively perform the task of transferring

632 the radial loads to the segmental lining and allowing the support system to be waterproofed,
633 preventing water from infiltrating inside the tunnel.

634 As for the deformation increase of the tunnel wall, the value of Δu can be determined on the
635 basis of equations 9 and 10 and considering that the stress $\sigma_{1,max,fm}$ inside the two-
636 component material tends to decrease progressively during the creep phase: it is therefore
637 necessary to adopt the average value that this stress assumes in this specific phase.
638 Therefore, assuming a tangent elastic modulus E_t at two days of curing equal to 40 MPa,
639 we obtain a ε_{creep} value of 0.0067 and an increase in the radial displacement of the tunnel
640 wall of about 31 mm. This increase in the deformations of the tunnel wall has the effect of
641 reducing the load applied on the segmental lining from the initial value of 0.86 MPa to the
642 final value (at the end of the creep phase) of 0.11 MPa. A consistent reduction of the acting
643 loads and of the stress state induced in the concrete which is often found when detailed
644 measures for monitoring the behavior of the segmental lining are available long times after
645 its installation.

646 **Conclusions**

647 The filling material inserted in the gap between the segmental lining and the tunnel wall has
648 several important roles aimed at ensuring the effectiveness of the support system of a tunnel
649 excavated with a TBM machine. Nowadays a **bi**-component filling material is widely used,
650 which has particular characteristics: a curing phase during which the mechanical parameters
651 evolve rapidly; a creep behavior with secondary deformations that develop over time when
652 the material is subjected to a stress load. These features make the interaction between the
653 support system and the tunnel complex, given that the filling material is loaded progressively
654 over time, starting from its installation into the gap between the segmental lining and the
655 tunnel wall. The creep phase generally comes into play at the end of the support system

656 loading phase and has as a consequence the reduction of the loads transmitted to the
657 segmental lining and the increase in deformations of the tunnel wall.

658 The creep phenomenon has been studied for many other materials in the field of
659 geotechnics and geomechanics. Many models have been developed and are known in the
660 scientific literature to represent the behavior of such materials. Although the two effects
661 mentioned above and induced by the creep of the filling material on the extrados of the
662 segmental lining are very important, no studies on this topic are available in the literature.

663 In particular, the increase in the radial displacement of the tunnel wall due to the
664 phenomenon of creep in the filling material can induce high subsidence on the soil surface
665 and can lead to conditions that are not compatible with the stability of the tunnel (exceeding
666 the maximum permissible values of the convergence tunnel).

667 In this work the results of an extensive laboratory experimentation on the creep behavior,
668 developed for different curing ages of the specimens and different load entities in relation to
669 the UCS of the material, are reported. It was possible to identify which is the maximum
670 compression stress where no failure of the material under a continuous load over time is
671 observed. In addition, it was possible to derive the recurring trend of deformations over time
672 (creep trend) by varying the curing ages and the stress state applied to the specimens.

673 The information obtained from the experimentation was then used to understand the effects
674 of the creep phase of the two-component material on the interaction between the support
675 system and the tunnel. In particular, it was possible to evaluate the decrease in the radial
676 load applied to the support system (and, therefore, to the segmental lining) and the increase
677 in the deformations of the tunnel wall. Finally, the application of the above considerations to
678 a real case of a tunnel excavated in Northern Italy in a weakly cohesive ground has allowed
679 to understand how the creep of the two-component material has non-negligible effects on

680 the final stress state induced in the segmental lining and on radial displacements of the
681 tunnel wall.

682 **Acknowledgment**

683 The authors wish to thank Master Builders Solutions by MBCC Group for the permission
684 granted to publish the results and to the reviewers' comments which increased the quality
685 of the manuscript.

686 **Conflict of interests**

687 Authors declare they have no conflict of interest.

688 **References**

689 Arnau, O., Molins, C., Blom, C.B.M., Walraven, J. (2011). Longitudinal time-dependent
690 response of segmental tunnel linings. *Tunnelling and Underground Space Technology*
691 *28(1):98, 10.1016/j.tust.2011.10.002.*

692 Barla, G. (2011). Contributions to the understanding of time dependent behaviour in deep
693 tunnels. *Geomech Tunnelling*; 4: 255-264.

694 Brown E.T., Bray J.W., Ladanyi B., Hoek E. (1983). Ground response curves for rock
695 tunnels. *Journal of Geotechnical Engineering*, 109, 1, 15-39
696 [https://doi.org/10.1061/\(ASCE\)0733-9410\(1983\)109:1\(15\)](https://doi.org/10.1061/(ASCE)0733-9410(1983)109:1(15))

697 Cardu, M. and Oreste, P. (2012). Technical-operational comparison between trench-cutters
698 and clam excavators for concrete diaphragm construction in underground works at shallow
699 depths. *Int. J. Min. Reclamat. Environ.*, 26, 3, 217–232.

700 Di Giulio, A., Bavasso, I., Di Felice, M., and Sebastiani, D. (2020). A preliminary study of the
701 parameters influencing the performance of two-component backfill grout. *Gallerie e Grandi*
702 *Opere Sotteranee*. 133. 11-17.

703 Do N.A., Dias D., Oreste P. (2014). Three-dimensional numerical simulation of mechanized
704 twin stacked tunnels in soft ground, *Journal of Zhejiang University: Science A*, 15(11):896–
705 913.

706 Do N.A., Dias D., Oreste P., Djeran-Maigre I. (2015a). 2D numerical investigation of
707 segmental tunnel lining under seismic loading. *Soil Dynamics and Earthquake Engineering*
708 72 (2015): 66-76.

709 Do N.A., Dias D., Oreste P. (2015b). 3D numerical investigation on the interaction between
710 mechanized twin tunnels in soft ground. *Environmental Earth Sciences*, 73(5):2101–2113.

711 Dusseault. M.B. Fordham. C.J. 1993. Time-dependent behavior of rocks. In Hudson JA. ed.
712 *Comprehensive Rock Engineering*. Pergamon Press: 119–149.

713 Farmer I.W. and Gilbert M.J. (1981). Time dependent strength reduction of rock salt. Proc.
714 1st Conf. on Mechanical Behaviour of Rock Salt, Pennsylvania State Univ.

715 Flores, A.Q. (2015). Physical and mechanical behavior of a two component cement-based
716 grout for mechanized tunneling application. MSc Thesis. Universidade Federal do Rio de
717 Janeiro. Brazil.

718 Geymayer, H.G. (1970). The effect of temperature on creep of concrete: a literature review.
719 U.S. Army Engineer Waterways Experiment Station Corps of Engineers, Vicksburg,
720 Mississippi.

721 Goodman, R. (1980). *Introduction to Rock Mechanics*. New York: Wiley.

722 Griggs, D. (1939). Creep of rocks. *The Journal of Geology*, 47, 3, 225-251.

723 Hardy H.R., Kim R.Y., Stefanko R. and Wang Y.J. (1969). Creep and microseismic activity
724 in geologic materials. Proc. 13th US Rock Mech. Symp., Berkeley, 377-413.

725 Hirata, T. (1989). Study on behavior of cohesive soil in type shield tunneling work and on
726 construction technique. Doctoral Thesis. Kyoto University. Japan.

727 Huber, H.G. (1991). Untersuchung zum Verformungsverhalten von jungem Spritzbeton im
728 Tunnelbau. Master Thesis. University of Innsbruck. Austria.

729 Jaeger, J.C.. Cook. N.G.W. (1979). Fundamentals of Rock Mechanics. London: Chapman
730 and Hall.

731 Kuwajima, F.M. Early age properties of the shotcrete. In Shotcrete for Underground VIII.
732 Celestino. T.B. and Parker. H.W.. eds.. Conference Eighth International Conference. São
733 Paulo. Brazil, April 11-15. 1999. American Society of Civil Engineers. Reston. VA.

734 Lama R.D. and Vutukuri V.S. (1978). Handbook on mechanical properties of rock. Testing
735 techniques and results. Vol. III, Trans Tech Publ.

736 Li., J., Sun. G., Zou, H., Zhou, Z., Fan, X. (2019). Influence of temperature and load on creep
737 characteristics of soft rock similar materials. IOP Conf. Series: Earth and Environmental
738 Science 384, 012229, doi:10.1088/1755-1315/384/1/012229.

739 Melbye, T. (1994). Sprayed Concrete for Rock Support. Switzerland: MBT Underground
740 Construction Group.

741 Ochmański, M.. Modoni, G. and Bzówka, J. (2018). Automated numerical modelling for the
742 control of EPB technology. Tunnelling and Underground Space Technology 75. 117–128.
743 <https://doi.org/10.1016/j.tust.2018.02.006>.

744 Ochmański, M., Modoni. G. and Spagnoli, G. (2021). Influence of the annulus grout on the
745 soil-lining interaction for EBP tunneling. Geotechnical Aspects of Underground Construction
746 in Soft Ground: Proceedings of the Tenth International Symposium on Geotechnical Aspects
747 of Underground Construction in Soft Ground, IS-Cambridge 2022, Cambridge, United
748 Kingdom, 27-29 June 2022, 350-356, DOI: 10.1201/9780429321559-45

749 Oggeri, C.. Oreste, P.. and Spagnoli, G. (2021). The influence of the two-component grout
750 on the behaviour of a segmental lining in tunnelling. Tunnelling and Underground Space
751 Technology. 109. 103750. <https://doi.org/10.1016/j.tust.2020.103750>.

752 Oh, J.Y. and Ziegler, M. (2014). Investigation on influence of tail void grouting on the surface
753 settlements during shield tunneling using a stress-pore pressure coupled analysis. KSCE
754 Journal of Civil Engineering. 18(3). 803-811. DOI: 10.1007/s12205-014-1383-8.

755 Oreste P. (2003). Analysis of structural interaction in tunnels using the convergence–
756 confinement approach, *Tunnelling and Underground Space Technology*, 18, 4, 347-363.

757 Oreste, P. (2007). A numerical approach to the hyperstatic reaction method for the
758 dimensioning of tunnel supports. *Tunnelling and Underground Space Technology*
759 22(2):185–205. <https://doi.org/10.1016/j.tust.2006.05.002>.

760 Oreste P (2009a). The convergence-confinement method: roles and limits in modern
761 geomechanical tunnel design. *American Journal of Applied Sciences* 6(4):757-771.

762 Oreste P (2009b). Face stabilisation of shallow tunnels using fibreglass dowels. *Proceedings*
763 *of the Institution of Civil Engineers-Geotechnical Engineering*, 162(2):95-109.

764 Oreste P. (2013). Face stabilization of deep tunnels using longitudinal fibreglass dowels.
765 *International Journal of Rock Mechanics and Mining Sciences*, 58:127-140.

766 Oreste P (2015). Analysis of the interaction between the lining of a TBM tunnel and the
767 ground using the convergence-confinement method. *American Journal of Applied Sciences*
768 12(4):276-283. DOI: 10.3844/ajassp.2015.276.283.

769 Oreste P., Spagnoli G., Ceravolo LA (2019) A numerical model to assess the creep of
770 shotcrete linings. *Proceedings of the Institution of Civil Engineers – Geotechnical*
771 *Engineering*. 172. 4. 344-354. <https://doi.org/10.1680/jgeen.18.00089>.

772 Oreste, P., Spagnoli, G., Luna Ramos, C.A. (2020). Evaluation of the safety factors of
773 shotcrete linings during the creep stage. *Proceedings of the Institution of Civil Engineers –*
774 *Geotechnical Engineering*. 173. 3. 274-282. <https://doi.org/10.1680/jgeen.19.00104>

775 Oreste, P., Sebastiani, D., Spagnoli, G., de Lillis, A. (2021) Analysis of the behavior of the
776 two-component grout around a tunnel segmental lining on the basis of experimental results
777 and analytical approaches. *Transportation Geotechnics*, 29, 100570,
778 <https://doi.org/10.1016/j.trgeo.2021.100570>

779 Orumchi, H. and Mojallal, M. (2017). Shear Strength Design of a Mechanized Tunneling
780 Grout Mix: Case Study of the Tehran Subway Line 6 Project. *Transp. Infrastruct. Geotech.*
781 4, 18–36. <https://doi.org/10.1007/s40515-017-0037-7>

782 Osgoui, R., and Oreste, P. (2007). Convergence-control approach for rock tunnels
783 reinforced by grouted bolts, using the homogenization concept. *Geotechnical and*
784 *Geological Engineering* 25(4):431-440, DOI: [10.1007/s10706-007-9120-0](https://doi.org/10.1007/s10706-007-9120-0).

785 Panet, M. (1995). *Calcul des Tunnels par la Methode de ConvergenceConfinement*. Paris:
786 Press de l'Ecole Nationale des Ponts et Chaussées.

787 Pelizza S., Oreste P., Peila D., Oggeri C. (2000). Stability analysis of a large cavern in Italy
788 for quarrying exploitation of a pink marble. *Tunnelling and Underground Space Technology*,
789 15(4):421–435.

790 Price A.M. and Farmer I.W. (1981). The Hvorslev surface in rock deformation. *Int. Journ. Of*
791 *Rock Mech. And Min.Sci.*, 18, 229-34.

792 Ranjbarnia M., Fahimifar A., Oreste P. (2014). A simplified model to study the behavior of
793 pre-tensioned fully grouted bolts around tunnels and to analyze the more important
794 influencing parameters. *Journal of Mining Science* 50(3):533-548

795 Ranjbarnia, M., Fahimifar, A., Oreste, P. (2016). Practical method for the design of
796 pretensioned fully grouted rockbolts in tunnels. *International Journal of Geomechanics*,
797 16(1), 04015012

798 Rahmati, S., Chakeri. H., Sharghi. M., Dias, D. 2021. Experimental study of the mechanical
799 properties of two-component backfilling grout. *Proceedings of the Institution of Civil*
800 *Engineers - Ground Improvement*. <https://doi.org/10.1680/jgrim.20.00037>.

801 Rokahr, R.B. Lux, K.H. (1987). Einfluss des rheologischen Verhaltens des Spritzbetons auf
802 den Ausbauwiderstand. *Felsbau*. 5:11-18.

803 Shah, R., Lavasan, A.A., Peila, D., Todaro, C., Luciani, A. and Schanz, T. (2018). Numerical
804 study on backfilling the tail void using a two-component grout. *J. Mater. Civ. Eng.*, 30(3):
805 04018003.

806 Sharghi, M., Chakeri, H., Afshin, H., and Ozcelik, Y. 2018. An experimental study of the
807 performance of two-component backfilling grout used behind the segmental lining of a
808 Tunnel-Boring Machine. *Journal of Testing and Evaluation*, 46, 5, 2083–2099.
809 <https://doi.org/10.1520/JTE20160617>.

810 Spagnoli G., Oreste P., Lo Bianco L. (2016). New equations for estimating radial loads on
811 deep shaft linings in weak rocks. *International Journal of Geomechanics* 16(6): 06016006.
812 DOI: [10.1061/\(ASCE\)GM.1943-5622.0000657](https://doi.org/10.1061/(ASCE)GM.1943-5622.0000657).

813 Spagnoli G., Miedema S.A., Herrmann, C., Rongau J., Weixler, L., Denegre J. (2016)
814 Preliminary Design of a Trench Cutter System for Deep-Sea Mining Applications Under
815 Hyperbaric Conditions. *IEEE Journal of Oceanic Engineering* 41, 4, 930 – 943,
816 [10.1109/JOE.2015.2497884](https://doi.org/10.1109/JOE.2015.2497884).

817 Thewes, M. and Budach, C. (2009). Grouting of the annular gap in shield tunnelling-An
818 important factor for minimisation of settlements and production performance. *Proceedings*
819 *of the ITA-AITES World Tunnel Congress 2009 “Safe Tunnelling for the City and*
820 *Environment”*. pp. 1–9.

821 Thomas, A. (2009). *Sprayed concrete lined tunnels*. Oxon: Taylor and Francis.

822 Todaro, C., Peila, L., Luciani, A., Carigi, A., Martinelli, D. and Boscaro, A. (2019). Two
823 component backfilling in shield tunneling: laboratory procedure and results of a test
824 campaign. In *Proceedings of the WTC 2019 ITA-AITES World Tunnel Congress (WTC*
825 *2019)*. May 3-9, 2019. Naples, Italy. Peila, D., Viggiani, G. and Celestino, T. (eds). CRC
826 Press, Boca Raton.

827 Van der Schyff J.J. (2017). Quantifying the creep behaviour of polyester resin and grout.
828 Proceedings of the 17th Coal Operators' Conference, Mining Engineering, University of
829 Wollongong.

830 Yin, J. (1996). Untersuchungen zum zeitabhängigen Tragverhalten von tiefliegenden
831 Hohlräumen im Fels mit Spritzbeton. PhD Thesis. Clausthal University of Technology.
832 Germany.

833 Yu, C.W. 1998. Creep characteristics of soft rock and modelling of creep in tunnel:
834 determination of creep characteristics of soft rock and development of non-linear creep
835 analysis code for squeezing tunnel problem. PhD Thesis. University of Bradford. UK.

836 **FIGURE CAPTION**

837 **Fig. 1 Section of EPB-TBM with some main aspects highlighted**

838 **Fig. 2: Two examples of creep with a staged loading on evaporitic rocks. Specimen a)**
839 **is entirely made of salt, with microcrystals from millimetric to centimetric size (see**
840 **figure on the right); after an initial stable load at 14.1 MPa, failure is reached with a**
841 **step at 18.8 MPa. Specimen b) is a fine-grained salt including elements of marl; after**
842 **an initial load at 29.9 MPa, failure is reached with a step at 34.2 MPa.**

843 **Fig. 3 Left: Twin cells adapted in the oedometer frame, where specimens are kept**
844 **submerged during constant load application and vertical settlement of the base is**
845 **continuously measured. Right: detail of a specimen inside a testing cell.**

846 **Fig. 4 Example of standard specimens prepared and obtained for UCS and creep**
847 **testing. The grain size of the cured grout specimens appears regular and**
848 **homogeneous, without veins or lenses of different consistency.**

849 **Fig. 5. Examples of vertical stress – vertical strain curves for grout specimens at**
850 **different curing age (at 24 hours, 7 days and 28 days from curing beginning,**
851 **respectively), during a uniaxial compressive test. Along the vertical axis applied**
852 **stress σ in MPa is reported, along horizontal axis induced vertical strain in ε (ratio of**
853 **the vertical displacement on the sample height) is reported. Strain softening after the**
854 **stress peak is more evident for short age curing specimens.**

855 **Fig. 6. Different failure modes for specimens after unconfined compression testing.**
856 **The formation of conical shaped bodies is clearly visible at left and in the middle. On**
857 **the right, the radial expansion has prevailed with symmetrical formation of vertical**
858 **slabs.**

859 **Fig. 7 Net settlement versus time are reported, for the three selected curing periods,**
860 **respectively 1 day (graph A with 2 stable behavior, 1 stable failure, 1 unstable failure);**
861 **7 days (graph B with 1 stable behavior, 1 stable failure, 2 unstable failure); 28 days**
862 **(graph C with 2 stable behavior and 1 unstable failure).**

863 **Fig. 8. Different failure modes for specimens after creep (constant load). A) de-**
864 **assembled specimen, failure with conical end shape, curing 1 day; B) failure with axial**
865 **symmetry for lateral expansion, 7 days curing; C) failure with conical end shape, 28**
866 **days curing.**

867 **Fig. 9. Trend of deformations over time in a sample of two-component material cured**
868 **for 7 days and subjected to an axial load equal to 33% of UCS. After the application**
869 **of the load, there is a significant increase in displacements in the first 10 minutes,**
870 **after which the displacements grow with a markedly bi-linear trend (zones 1 and 2 in**
871 **the graph) until stabilization is reached after about 14 days from loading.**

872 **Fig. 10 The intersection between the convergence-confinement curve of the tunnel**
873 **and the reaction line of the support system when this is composed of segmental lining**
874 **and the two-component material around it (modified by Oreste et al., 2021). Legend:**
875 **p : internal pressure applied to the tunnel wall; u : radial displacement of the tunnel**
876 **wall; p_0 : lithostatic stress in the soil or rock at the depth of the tunnel; u_0 :**
877 **displacement of the tunnel wall at the distance from the excavation face of the section**
878 **where the support system is installed; $u_{max} = (1 + \nu_{gr}) \cdot p_0 \cdot R / E_{gr}$, where E_{gr} is the**
879 **elastic modulus and ν_{gr} the Poisson's ratio of the ground (soil or rock) present around**
880 **the tunnel; R is the tunnel radius; p_{eq} and u_{eq} : respectively the load applied on the**
881 **support system and the radial displacement of the tunnel wall in the final condition**
882 **of equilibrium, at the end of the process of loading the support system.**

883 **Fig. 11. Representation of the creep phenomenon in the filling material once the final**
884 **equilibrium point is reached at the end of the process of placing the support system**
885 **in charge. Legend: Δu : increase in the radial displacement of the tunnel wall due to**
886 **the creep of the filling material.**

887 **Fig. 12. Convergence-confinement curve of the tunnel and reaction line of the support**
888 **system in the examined case: tunnel with a diameter of 9.4 m at a depth of 70 m**
889 **excavated in a weakly cohesive soil with an elastic modulus E_{gr} of 150 MPa. The**
890 **support system consists of a 0.35 m thick segmental lining and a 0.15 m thick filling**
891 **material ring. The red line represents the modification of the equilibrium point on the**
892 **convergence-confinement curve following the creep phenomenon in the filling**
893 **material.**

25 **Key words:** two-component grout; curing age; Tunnel Boring Machine (TBM); convergence-
26 confinement method (CCM); creep-behaviour.

27

28 **Abbreviations and nomenclature**

- 29 E_{fm} Elastic modulus of the filling material
- 30 E_{gr} Elastic modulus of the ground
- 31 E_s Secant elastic modulus
- 32 E_{sl} Elastic modulus of the segmental lining (concrete)
- 33 E_t Tangent elastic modulus
- 34 $E_{t,\alpha}$ Tangent elastic modulus of the filling material associated with a percentage load level
- 35 α referred to the Unconfined Compressive Strength (UCS)
- 36 $E_{t,35\%}$ Tangent modulus of elasticity measured at a stress level equal to 35% of UCS
- 37 $k_{sys,fin}$ Stiffness of the support system at the end of the loading process
- 38 k_{sys} Stiffness of the support system
- 39 $k_{sys,in}$ Stiffness of the support system at the beginning of the loading process
- 40 k_{sl} Radial stiffness of the segmental lining
- 41 k_0 Coefficient of earth pressure at rest
- 42 p Pressure inside the tunnel acting on the walls
- 43 p_{eq} Final entity of the loads acting on the support system
- 44 p_0 Hydrostatic initial stress state (undisturbed)
- 45 R Tunnel radius
- 46 t_{fm} Thickness of the filling material

47	t_{sl}	Thickness of the segmental lining
48	UCS	Unconfined compressive strength
49	u_{eq}	Final entity of the tunnel wall displacement
50	u_0	Displacement of the tunnel wall when the support system is installed
51	u_{max}	Maximum displacement of the tunnel wall in the absence of supports
52	ν_{fm}	Poisson's ratio of the filling material
53	ν_{gr}	Poisson's ratio of the soil or rock present around the tunnel
54	ν_{sl}	Poisson's ratio of the concrete constituting the segmental lining
55	α	Percentage of the stress level acting in the filling material with respect to the UCS
56		strength
57	δ_{inst}	Immediate displacement in the filling material
58	ε	strain (ratio of the the displacement on the reference height)
59	ε_{creep}	creep strain of the filling material
60	ε_{inst}	Immediate deformation of the filling material
61	η	Long-term strength of the two-component material as a percentage of the UCS
62	ω	Correction coefficient taking into account the deformation increase that occurs in the
63		first 10 minutes of load during a creep test
64	σ	Applied or induced stress

65 Δu Increase in the radial displacement of the tunnel wall due to the creep phenomenon
66 of the filling material

67

68 Introduction

69 The backfilling (or tail void grouting) is the system used during the excavation of a tunnel by
70 means of a TBM (Tunnel Boring machine) to fill the void created during the advancement of
71 the machine between the support structure and the rock wall. **As a matter of fact, when**
72 **tunneling is carried out using a shield machine and a segmental lining, there is a gap caused**
73 **by the overcut due to the slightly larger diameter of the shield machine than the lining**
74 **(Sharghi et al., 2018) and to the thickness of the shield and the space occupied by the**
75 **brushed, which close the void lining-shield (see Fig. 1). This gap is needed in order for the**
76 **TBM to curve left/right (planimetric curves) or up/down (altimetric curves).**

77 The instantaneous filling of the annulus that is created behind the segment lining at the end
78 of the TBM tail during its advancement is a very important operation. The objective is to
79 minimize the surface settlements induced by the passage of the TBM, **to assure that the**
80 **tunnel convergence is within the allowable limit**, to ensure the homogeneous transmission
81 of stresses between the soil/rock mass and the lining, to avoid misalignments of the linings
82 and to provide impermeabilization of the tunnel (Thewes and Budach, 2009; Di Giulio et al.,
83 2020; Oggeri et al., 2021). Different types of materials are used to fill the gap, however lately
84 the two-component grout system is becoming more popular (e.g. Di Giulio et al., 2020;
85 Oggeri et al., 2021; Rahmati et al., 2021). To correctly achieve this, a simultaneous
86 backfilling system and the injected material should satisfy the technical, operational and
87 performance characteristics: the two-component grout must be water-tight, pumpable,
88 workable, able to fill the void, to stiff quickly and to be wash-out resistant, not able to shrink
89 (e.g. Thewes and Budach, 2009; Oggeri et al., 2021).

90 For these reasons, the open space must be continuously filled during the machine's
91 advancement.

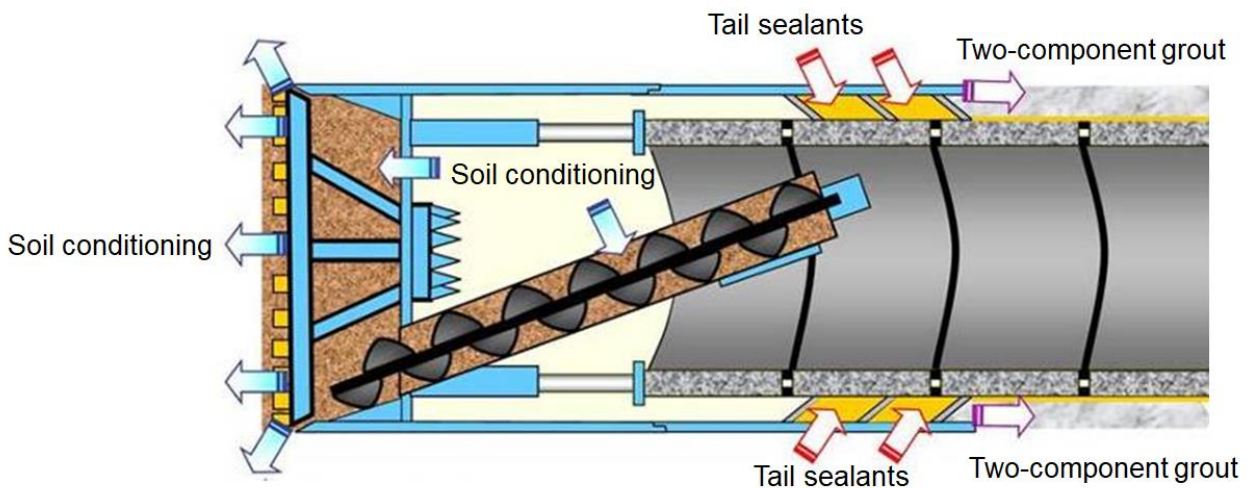

92

93 **Fig. 1 Section of EPB-TBM with some main aspects highlighted**

94 The mix-design of a two-component grout is claiming for different requirements depending
 95 on the job site characteristics and geological formation; however, the typical mix-design in
 96 a m³ system for a two-component grout consists in general by cement (280-450 kg),
 97 bentonite (30-60 kg), water (730-860 kg), retarder (3-5 kg) and accelerator (60-80 kg),
 98 normally sodium silicate. The accelerator (“B” component) is generally added just before the
 99 pumping phase of the mix of water, bentonite, retarder and cement (“A” component).
 100 Simultaneous backfilling with two-component grouts, in comparison with the mortar type
 101 grouts, keeps in general lower settlements during TBM excavation (Hirata, 1989). Keeping
 102 in mind the importance of the two-component grout during tunneling advancement, it must
 103 be recognized that not many works deal with this material both experimentally and
 104 numerically. It is well-known that the mechanical properties of the two-component grout
 105 change based on the mix-design type (e.g. Flores, 2015; Todaro et al., 2019).
 106 Oh and Ziegler (2014), Shah et al. (2018), Ochmański et al. (2018) and more recently
 107 Ochmański et al. (2021) performed a numerical analysis regarding the effects of the two-
 108 component grout on the tunnel settlement. However, the creep behavior of two-component
 109 grouts has not be analyzed in details so far. In this paper, a mix-design of a two-component
 110 grout has been tested by determining the Unconfined Compressive Strength (UCS) and the

111 creep strain evolution at varying curing ages. From the analysis of the laboratory results it
112 was possible to understand the behavior of this material with particular attention to the
113 deformability and strength values during a loading phase and the analogous response to
114 long term loading, by maintaining different loads acting on the specimen. It was possible to
115 describe the development of deformations over time of the two-component material
116 subjected to different load entities related to the UCS. From the analysis of the laboratory
117 results it was possible to describe a behavioral model of the creep phase of the two-
118 component material and also to evaluate the effects of the evolution of deformations over
119 time on the behavior of the segmental lining and on the displacements of the tunnel wall.
120 The analysis of a real case of a tunnel excavated in Northern Italy in a weakly cohesive
121 material allowed to verify the effects of the creep of the two-component material on the
122 behavior of the support system, arriving at evaluating the reduction over time of the loads
123 applied to the segmental lining (stress relief) and the increase in the radial displacement of
124 the tunnel wall at the end of the creep phase.

125 **General creep models**

126 Due to the strains increase with time in tunnelling, creep can be an important phenomenon,
127 especially for very soft or heavily fractured rocks under significant in-situ stresses (Yu, 1998;
128 Dusseault and Fordham, 1993), for rocks of argillaceous nature (Barla, 2011) or also when
129 a combination of applied stresses and material properties, some specific geological
130 conditions, and/or a groundwater flow exist. For rocks containing clay, the phenomenon,
131 associated with water migration (or clay platelets orientation), could be considered as a
132 consolidation typology (Goodman, 1980).

133 When a specimen is subjected to a constant maintained load in unconfined compression in
134 the microfracturing range, the specimen will continue to deform after initial application of the
135 load (Hardy et al., 1969). Normally creep strain are not fully recovered; therefore, large

136 plastic deformations take place (Dusseault and Fordham, 1993). Time dependent strain is
137 much higher in weak rocks and evaporites than in stiffer rocks, but the typical shape of the
138 strain trend is similar. Three reference types of deformation can be **observed** following the
139 strain trend under a maintained stress (Farmer and Gilbert, 1981):

140 a) level of applied load is maintained above a critical microcrack development level, then
141 unstable fractures will accelerate creep strains and quickly leading to specimen
142 failure;

143 b) level of stress is well below the critical microcrack development level, there will be a
144 limited spreading of fractures with an exponentially decaying of the creep strain rate
145 and stable conditions (no failure);

146 c) the intermediate zone represents a meta-stable condition, where cracks propagation
147 can occur leaving stable microfractures and reaching unstable conditions with crack
148 acceleration and failure. This can happen also with staged conditions of loading
149 (Figure 2, Oggeri, unpublished data).

150 **Figure 2 shows an example of evaporitic rock presented for comparison with different**
151 **behaviour with deformation under constant loading. Trend of the curves, threshold levels for**
152 **both stress and strain and final control of specimen integrity can differ during testing.**
153 **Therefore, a dedicated experimental approach is deemed necessary for any new material.**
154 **Specimen a) and b) are coming from the same deposit, but even small differences in texture**
155 **and grain size of particles are influencing the test results.**

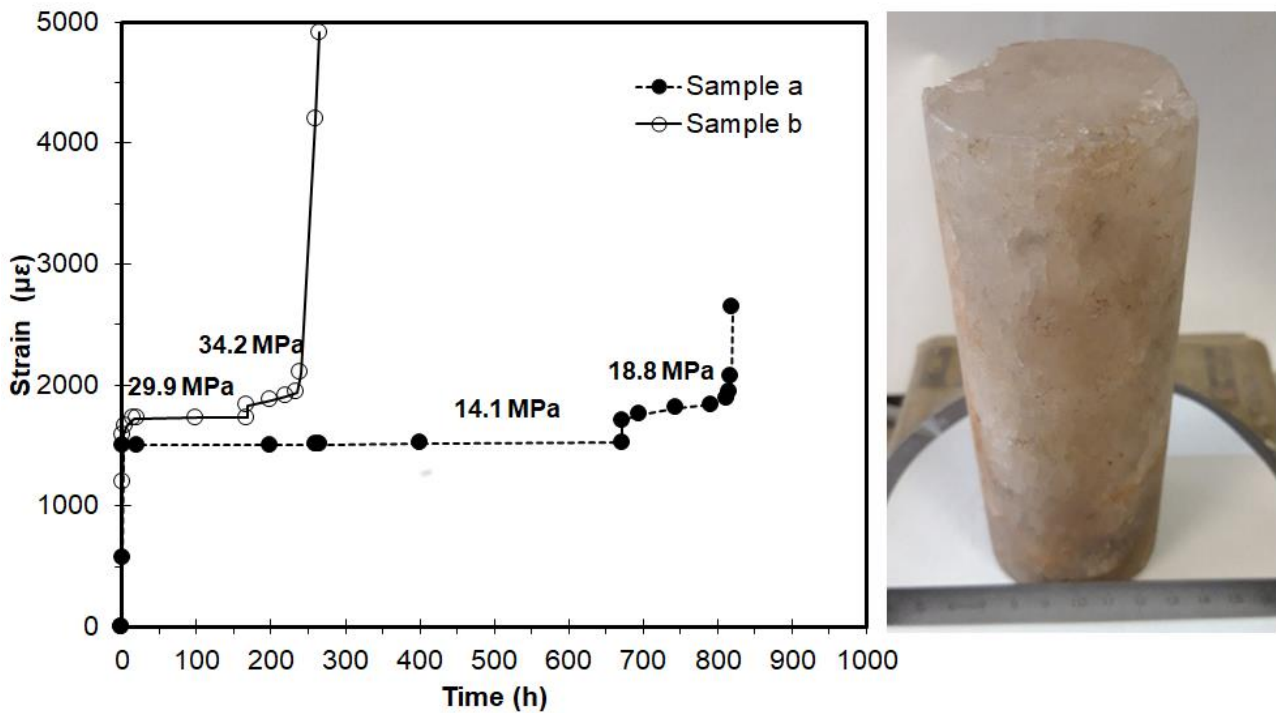

156

157 **Fig. 2: Two examples of creep with a staged loading on evaporitic rocks. Specimen a)**
 158 **is entirely made of salt, with microcrystals from millimetric to centimetric size (see**
 159 **figure on the right); after an initial stable load at 14.1 MPa, failure is reached with a**
 160 **step at 18.8 MPa. Specimen b) is a fine-grained salt including elements of marl; after**
 161 **an initial load at 29.9 MPa, failure is reached with a step at 34.2 MPa.**

162 Many models of creep and testing procedures have been carried out after the extended
 163 research by Griggs (1939) and refinements after Lama and Vutukuri (1978). Alternative
 164 approaches have been developed by Price and Farmer (1981).

165 In tunneling, many models are used to describe the creep of rocks and sprayed concrete,
 166 e.g. rheological models (Jaeger and Cook, 1979), Kelvin model (Neville et al. 1983; Jaeger
 167 and Cook, 1979; Rokahr and Lux 1987), Burgers model (Yin 1996), viscoplastic model
 168 (Thomas 2009). In sprayed concrete creep is significantly higher at an early stage of load
 169 as the strength of sprayed concrete is lower, as found by Huber (1991), who observed that
 170 a sample loaded at 8 days creeps by 25% more than a similar sample loaded at 28 days.

171 However, it must be kept in mind that some accelerators increase the early strengths
172 (Melbye 1994) therefore creep after 24 or 48 h is close to that at greater ages (Kuwajima
173 1999). Besides, studies have been carried out for the assessment of creep reaction of grout
174 for rockbolts (Van der Schyff, 2007), or for a new method for designing the grout mix based
175 on the induced shear stress rather than on the compressive strength (Orumchi and Mojallal,
176 2017); other contributions have been given for the creep behavior of a grouted sand
177 (Delfosse-Ribey et al., 2006): depending on the nature of the grout, the grouted sand has
178 exhibited creep strains of different degrees; moreover, similarities can be found for both
179 creep behavior and fatigue behavior as found trend curves have showed similar shapes.

180 Arnau et al. (2011) provided analyses in order to study the backfill grout behavior and its
181 influence on the longitudinal response of the lining in plane strain. Three different grout
182 moduli of elasticity were used in the analysis for each different ground condition. An
183 assessment of the influence of grout shrinkage was also performed by assuming a value of
184 0.05 mm/m according to favorable curing conditions. The results showed that the modulus
185 of elasticity of the grout was not presenting a significant influence on the lining axial stress,
186 while tensile cracking for very stiff grouts could occur and that the lining creep and the grout
187 shrinkage were not significantly influencing the grout tensile stress for general tunnel
188 conditions. Backfill grout cracking was unable to influence negatively the radial structural
189 capacity of the segmental lining, while caused a reduction in the water-tightness of the lining.

190 It must be pointed out that in some cases (hydraulic tunnels) there is a significant internal
191 pressure in the tunnel which forces the backfilling mortar to play a crucial role of contact
192 between lining and rock mass. Besides, over time cracks lead to a loss of confinement of
193 the same backfilling material which, consequently, significantly reduces its mechanical
194 characteristics which could also lead to significant alignment/structural problems in the
195 lining.

196 As final comment, the annulus grout material may remind of clay (bentonite)-cement slurries
197 for diaphragm wall applications (e.g. Cardu and Oreste, 2012; Spagnoli et al., 2016).
198 Although creep behavior may be studied, operative care is focused mainly on integrity, low
199 permeability performances, self-sealing properties, as well local displacement of the
200 structure *in situ*. For the annulus grout loading values are changing together with curing, and
201 stiffness and time performance is governing the interaction between a soft material (usually
202 the ground) and a very stiff material (the concrete segments).

203 **Laboratory creep behavior of the two-component grout**

204 The tested two-component mix-design adopted for this experimental campaign was based
205 on the following parts:

- 206 • Part A: water 800 g, bentonite 35 g, cement (CEM I 52.5) 350 g, retarder 17.5 g
207 (solution contains 20% solid therefore retarder dosage by weight of cement is 1%);
- 208 • Part B: water glass (sodium silicate) 85 g.

209 Part B is added at the end of mixing of the mentioned components as it reacts quickly by
210 producing a viscous grout (water glass represents about 7% of added weight to the initial
211 mix). Grout has been prepared starting from the bentonite hydration (duration at least 48
212 hours), then the slurry has been maintained for another 24 hours at low stirring. The mixing
213 with retarder and cement has been arranged directly inside the casing of the specimens, by
214 manual dispersion; finally, water glass catalyst has been injected into the fluid grout and a
215 high-speed rotating mixer (up to 8000 rpm) has been used during this phase. Every
216 specimen has been prepared by respecting the mass percentages provided for the standard
217 mix; weight of the components has been determined by means of 0.01 g precision scale.

218 Fast rotation of mixer has allowed to disperse the catalyst and homogenize the grout inside
219 the casing. Then, the casings containing the specimens have been recovered in a box for

220 curing in water. Curing procedure has been selected following three different timelines for
221 testing: 24 h; 7 days; 28 days. Preparation of the specimen requires great care and repeated
222 preliminary attempts were done in order to obtain a suitable material. **Temperature during**
223 **the tests has been kept constant at 19-21°C.**

224 UCS has been carried out in a Belladonna mechanical press for soils, equipped with
225 bidirectional displacement rate control device. Transducers used to measure load and
226 vertical displacement have been respectively a full bridge load cell (CCT model, full scale 5
227 kN and precision of 1 N) and LVDT devices (HBM models, precision 0.001 mm). Vertical
228 displacements have been measured following the relative movement of the base of the
229 specimen. Advancing rate has been adapted in the range of 0.15 ÷ 0.45 mm/min and
230 suitable results have been obtained for the range 0.30 ÷ 0.45 mm/min. This selection is a
231 good compromise to avoid creep behavior (excess of lateral swelling) or sudden failure
232 (vertical cracks). Specimen diameter has been selected as 46.5 mm.

233 Creep testing has been performed by using a standard mechanical oedometer (Belladonna
234 equipment) (Fig. 3), with settings to host the cell (a graduated plastic cylinder) with water
235 and the specimen. **The host cell was made of stiff and transparent polypropylene and the**
236 **contact base with the specimen has been provided of a flat stainless-steel disk to avoid any**
237 **local deformation.** A similar arrangement was already successfully used by Delfosse-Ribey
238 et al. (2006).

239 **The adaptation of a classical Bishop lever oedometer has been done in order to fit the**
240 **expected strength level of the grout, if compared with typical properties of rock material**
241 **tested for creep (salt, coal, gypsum etc.). This equipment permits:**

- 242 • **to work from very low to medium stress levels;**
- 243 • **to provide a perfect vertical alignment of caps at the extremities of the specimen;**
- 244 • **to provide a full recovery of mechanical gaps during assembling of specimens;**

- 245 • an easy water saturation control in open cells and drainage filters at contact with the
246 specimens;
- 247 • to continuously read the vertical displacement versus time; easy and direct check of
248 macroscopic cracking growth or lateral bulging.

249 The procedure for testing is following some steps: 1) preparation of the specimen with
250 selected mix and curing time in submerged conditions; 2) weighting and photos of the
251 specimen; 3) assembling inside the cell and filling of the cell with water; 4) mechanical gap
252 recovery of the displacements of the apparatus; 5) application of the selected load on the
253 lever arm in order to reach the selected stress level, according to previous experience
254 gained in uniaxial compression tests; 6) measurement of vertical displacement versus time;
255 7) detection of the trend and completion of the testing duration after reaching either a failure
256 (stable failure when residual bearing capacity is evident; unstable failure when specimen
257 start to yield and collapse) or a constant settlement; 8) removal of load and measurement
258 of eventual elastic strain recovery; 9) removal of the specimen, taking photos to verify the
259 crack pattern and weighting for moisture content.



261 **Fig. 3 Left: Twin cells adapted in the oedometer frame, where specimens are kept**
262 **submerged during constant load application and vertical settlement of the base is**
263 **continuously measured. Right: detail of a specimen inside a testing cell.**

264 It is important to specify that standard test procedure for one-dimensional consolidation
265 properties of soils have been adapted in order to respect the fact that grout is curing during
266 testing: this is not the case for natural minerals such as salt or gypsum. After some practical
267 preliminary tests, repeatability and representativity have been observed for loading periods
268 of no more than one week after 24 hours of initial curing and of no more than four weeks
269 after 7 days and 28 days from curing beginning. Specimens have been maintained saturated
270 during cycles to avoid cracking, and displacements have been measured by means of
271 potentiometric transducers with precision of 0.01 mm. Fig. 4 shows the specimens used for
272 the tests. Quality in terms of homogeneity and geometry was considered acceptable.



273

274 **Fig. 4 Example of standard specimens prepared and obtained for UCS and creep**
275 **testing. The grain size of the cured grout specimens appears regular and**
276 **homogeneous, without veins or lenses of different consistency.**

277 *UCS results*

278 The main results after unconfined compression testing are reported in Table 1. Strength is
279 considered as the maximum value of stress obtained, for the great majority of cases, at yield
280 at the end of the elastic domain. Deformability values are indexed as secant moduli, E_s , at
281 25%, 50% and 75% of the elastic domain and as tangential values, E_t , at 50% of the elastic
282 domain. In Fig. 5 there is a representative sequence of vertical stress – vertical strain curves
283 for different curing ages. The observed UCS values are rated similar than expected if
284 compared with other available results on this grout type (see Oggeri et al., 2021). Vertical
285 stress versus vertical strain is reliable both in the elastic and in the post peak field. A clear
286 yielding and softening behavior have been observed, with some subvertical and inclined
287 prevailing cracks. In some cases, a pseudo-conical shape at failure has been observed at
288 the extremities of the specimen, thus respecting the ideal Mohr-Coulomb strength criterion
289 (Fig. 6).

290

291 Tab. 1 Summary of specimen data for the UCS tests.

24 h curing	Diameter (mm)	Height (mm)	Weight (g)	Apparent unit weight (g/cm³)	UCS (kPa)	E_s 25% (MPa)	E_s 50% (MPa)	E_s 75% (MPa)	E_t 50% (MPa)
n.1	46.5	85	187.6	1.299	480	6.5	9.7	11.5	23.1
n.2	46.5	84.4	185.0	1.291	215	5.6	8.7	10.2	17.9
n.3	46.2	85.2	186.2	1.304	350	9	12.3	16.5	26.2
n.4	46.5	84.9	186.3	1.292	320	8.1	10.1	13.3	24.7
7 days curing	Diameter (mm)	Height (mm)	Weight (g)	Apparent unit weight (g/cm³)	UCS (kPa)	E_s 25% (MPa)	E_s 50% (MPa)	E_s 75% (MPa)	E_t 50% (MPa)
n.1	46.5	86	190.1	1.302	1270	25.8	34.1	42.6	78.1
n.2	46.5	86	192.0	1.314	1110	17.5	26.5	32.3	73.8
n.3	46.5	83	186.3	1.322	760	51.2	63	74.7	76.41
n.4	46.5	84	190.1	1.332	1150	38.5	50	55.4	117.8
n.5	46.5	89	192.6	1.274	990	33.3	43.2	54.6	109.9
28 days curing	Diameter (mm)	Height (mm)	Weight (g)	Apparent unit weight (g/cm³)	UCS (kPa)	E_s 25% (MPa)	E_s 50% (MPa)	E_s 75% (MPa)	E_t 50% (MPa)
n.1	46.5	83	183.3	1.300	1290	37.8	44.8	54.9	109.4
n.2	46.5	83	185.5	1.316	1110	20.4	26.2	32.7	63.3
n.3	46.5	84	188.6	1.322	1290	33.3	44	59.6	108.7
n.4	46.5	86	192.1	1.315	1400	30.1	43.1	57.1	111.2

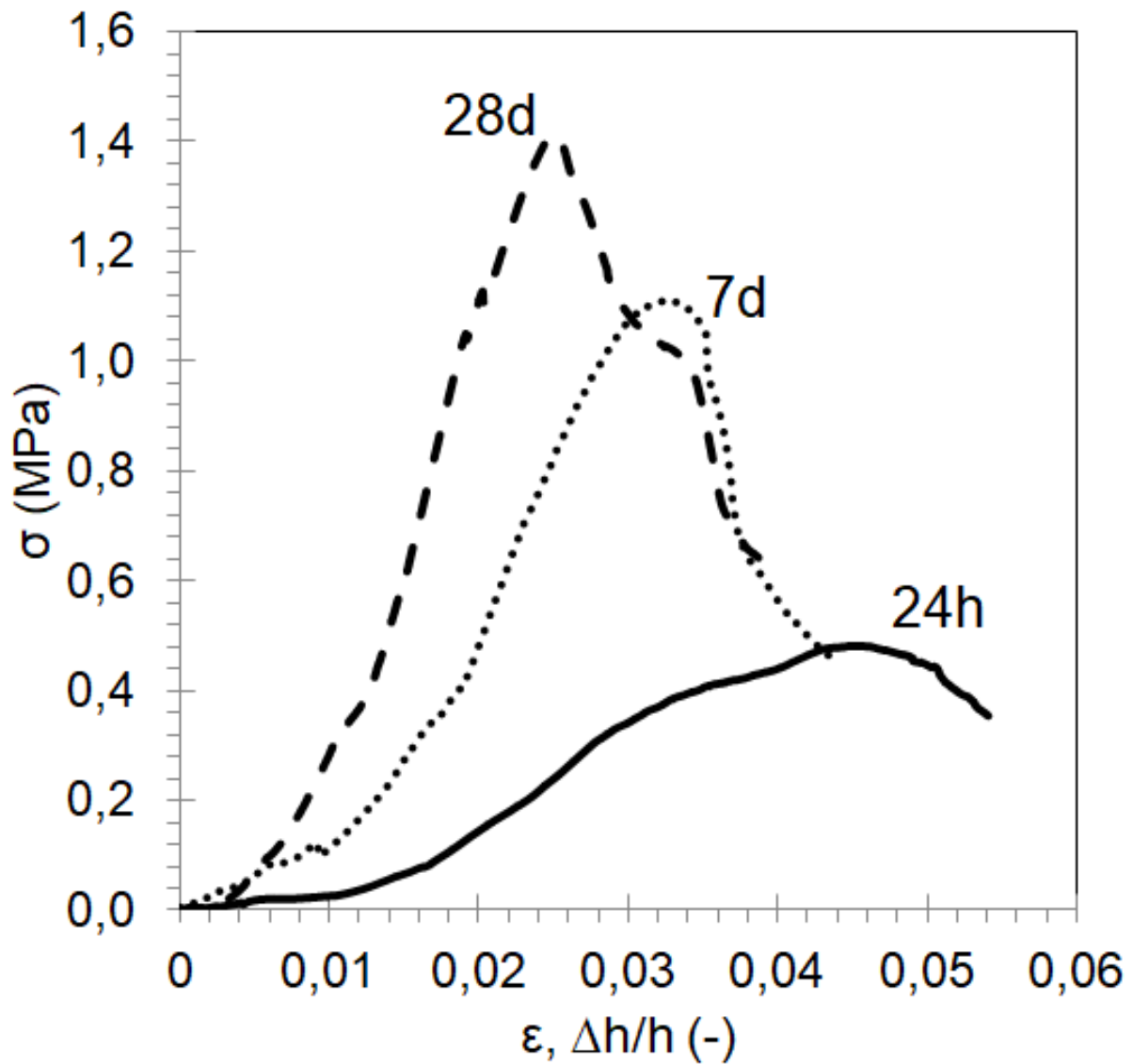

292

293 **Fig. 5. Examples of vertical stress – vertical strain curves for grout specimens at**
 294 **different curing age (at 24 hours, 7 days and 28 days from curing beginning,**
 295 **respectively), during a uniaxial compressive test. Along the vertical axis applied**
 296 **stress σ in MPa is reported, along horizontal axis induced vertical strain in ϵ (ratio of**
 297 **the vertical displacement on the sample height) is reported. Strain softening after the**
 298 **stress peak is more evident for short age curing specimens.**

299

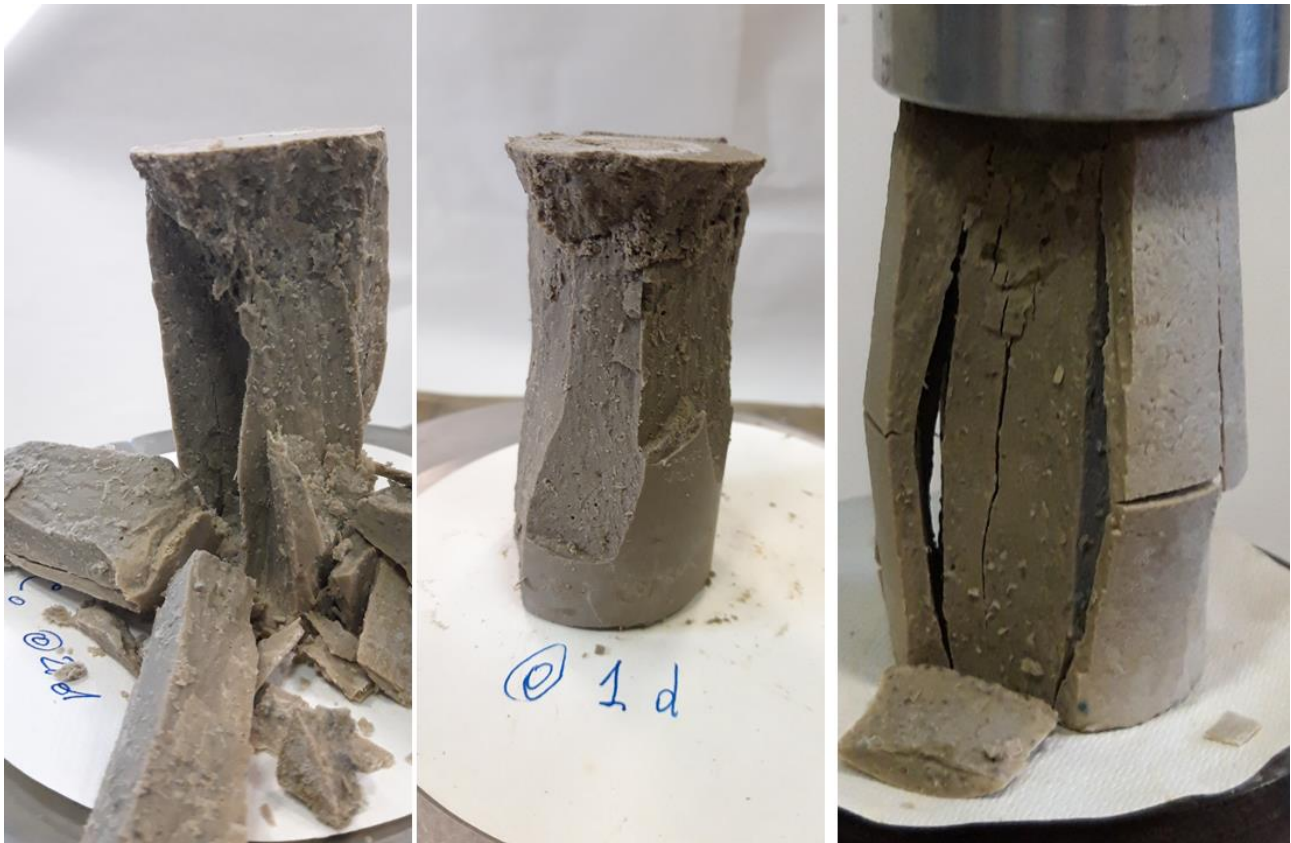

300

301 **Fig. 6. Different failure modes for specimens after unconfined compression testing.**
302 **The formation of conical shaped bodies is clearly visible at left and in the middle. On**
303 **the right, the radial expansion has prevailed with symmetrical formation of vertical**
304 **slabs.**

305 *Creep tests results*

306 Constant loading testing has been carried out on several specimens, and the selection of
307 regular behavior has been reported after exclusion of not homogeneous materials. In Table
308 2 the evidence of 11 tests is reported, with geometrical data and the applied vertical loads,
309 both effective and as a percentage of the reference value obtained from the compression
310 tests. The UCS has been determined in advance in order to properly assign a reasonable
311 ratio of the applied constant load, just because this ratio triggers the passage between a
312 stable and an unstable behavior.

313

314 **Tab. 2. Summary of specimen data for constant loading (creep) tests. Last column shows the load percentage referred to a**
 315 **representative value of UCS for the same type of grout and curing age.**

24 h curing	diameter (mm)	height (mm)	weight (g)	apparent unit weight (g/cm³)	σ creep (kPa)	σ creep (as % UCS)
n.1 creep	46.2	85.3	187.1	1.308	290	75
n.2 creep	46.5	85.2	186.2	1.287	230	60
n.3 creep	46.5	85.8	187.2	1.285	175	45
n.4 creep	46.5	87.6	189.2	1.270	115	30
7 days curing	diameter (mm)	height (mm)	weight (g)	apparent unit weight (g/cm³)	σ creep (kPa)	σ creep (as % UCS)
n.1 creep	46.5	87.0	192.0	1.300	700	66
n.2 creep	46.5	85.6	187.9	1.293	580	55
n.3 creep	46.5	93.8	203.8	1.279	460	45
n.4 creep	46.5	85.7	188.5	1.295	350	33
28 days curing	diameter (mm)	height (mm)	weight (g)	apparent unit weight (g/cm³)	σ creep (kPa)	σ creep (as % UCS)
n.1 creep	46.5	86.0	192.2	1.316	930	75
n.2 creep	46.5	85.1	189.4	1.312	700	55
n.3 creep	46.5	84.2	186.0	1.304	460	35

317 In Fig. 7 the net settlement versus time trend is reported, for the three selected curing
318 periods, respectively 1 day (A), 7 days (B) and 28 days (C). The tests have shown,
319 depending on the applied load magnitude:

- 320 • at 1 day of curing: a stable behavior for 2 specimens, a stable failure for 1 specimen,
321 an unstable failure for 1 specimen;
- 322 • at 7 days of curing: a stable behavior for 1 specimen, a stable failure for 1 specimen,
323 and unstable failure for 2 specimens;
- 324 • at 28 days of curing: a stable behavior for 2 specimens, an unstable failure for 1
325 specimen.

326 Fig. 8 shows some representative effects after the end of the creep test. It is possible to
327 observe how the grout can respond to a constant loading. It is necessary to remind that for
328 1 days and 7 days curing ages grout is still strengthening, even if failures occur due to
329 loading. Only for long term-curing, i.e. 28 days, it fair to state that full mechanical properties
330 of grout have been reached.

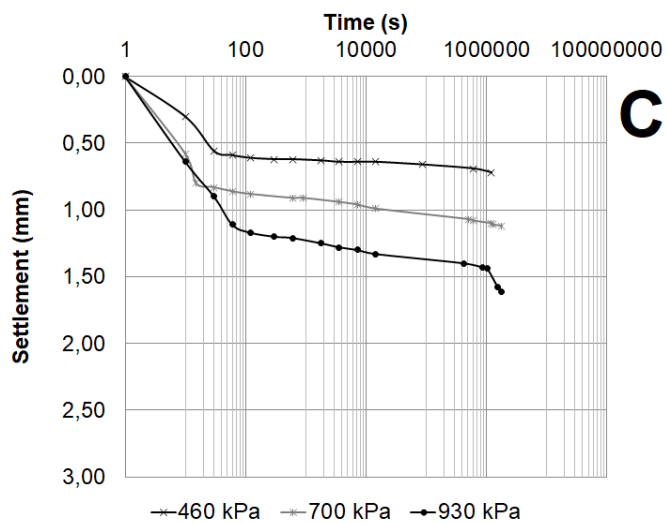
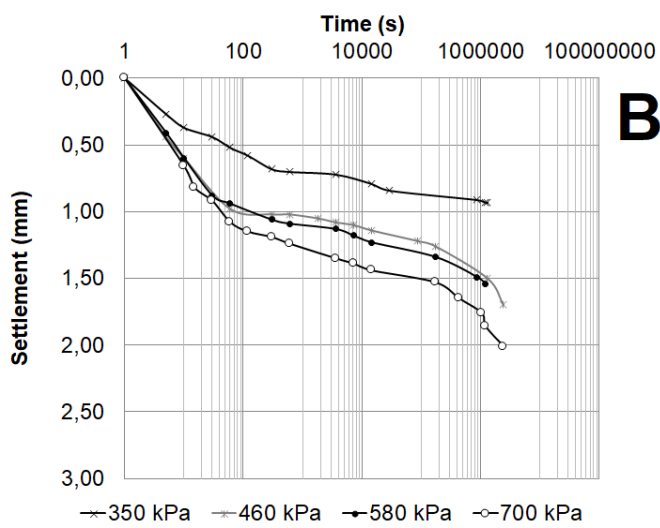
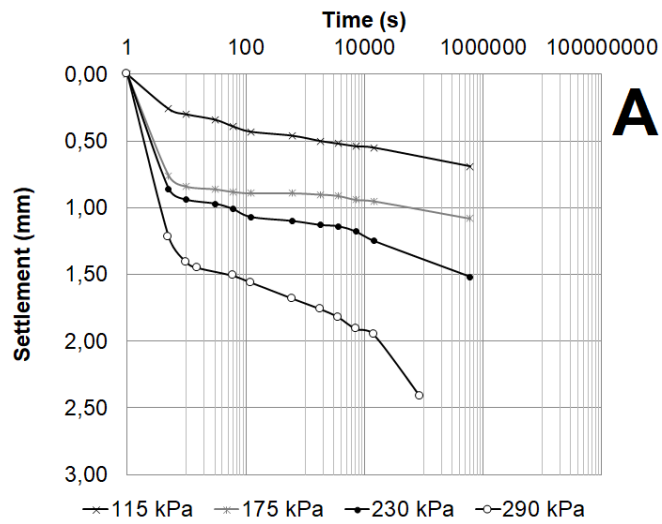

331

332 **Fig. 7 Net settlement versus time are reported, for the three selected curing periods,**
 333 **respectively 1 day (graph A with 2 stable behavior, 1 stable failure, 1 unstable failure);**

334 7 days (graph B with 1 stable behavior, 1 stable failure, 2 unstable failure); 28 days
335 (graph C with 2 stable behavior and 1 unstable failure).

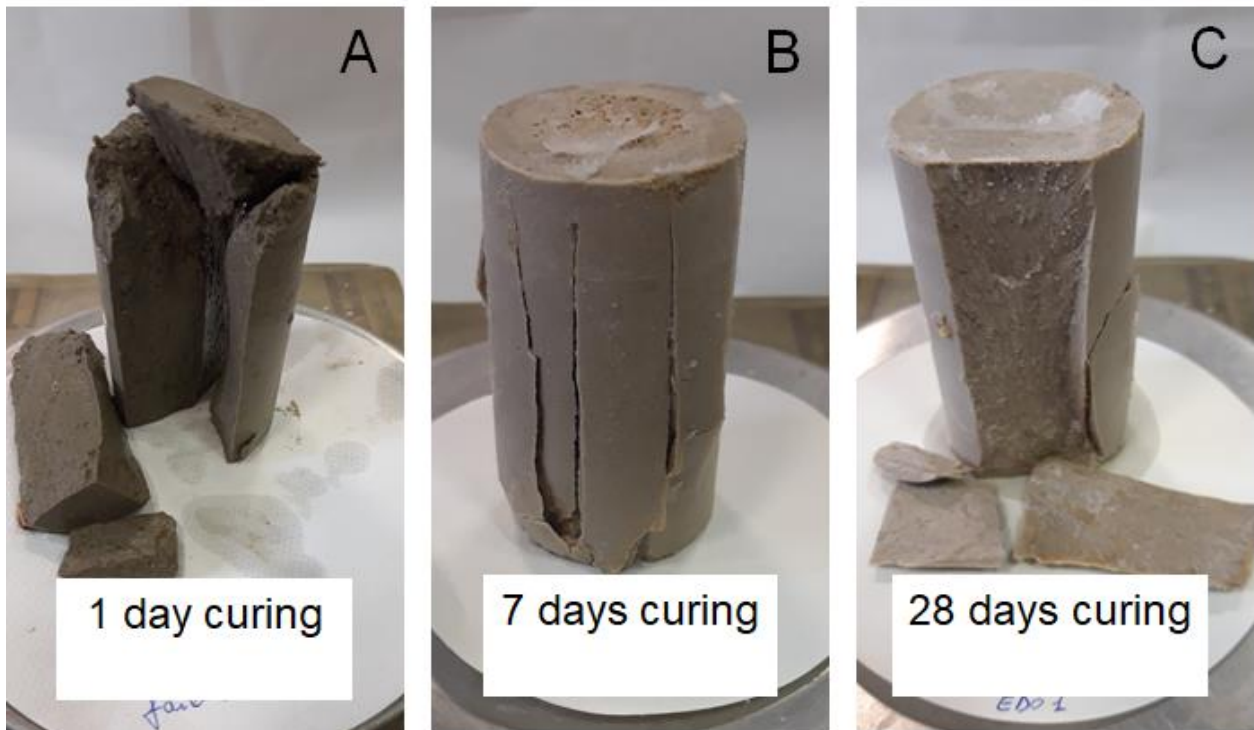

336

337 **Fig. 8. Different failure modes for specimens after creep (constant load). A) de-**
338 **assembled specimen, failure with conical end shape, curing 1 day; B) failure with axial**
339 **symmetry for lateral expansion, 7 days curing; C) failure with conical end shape, 28**
340 **days curing.**

341 **Comments of laboratory results**

342 The available data and the observed behavior during the standard compression test and
343 during compression tests with constant loads (creep tests), **for this mix-design**, can allow to
344 put in evidence some features:

- 345 • the mixing procedure carried directly inside the casing has determined a little increase
346 in the unit weight referred to the test results reported in a previous campaign, thanks

347 to the reduction of the weak material removal from the end of the specimen during
348 preparation;

- 349 • there is a general increase in UCS strength and in elastic moduli due to the previous
350 point;
- 351 • all specimens have shown a post peak behavior, with wider strain softening for
352 shorter curing ages;
- 353 • in some cases, a clear evidence of conical shaped ends at failure of the specimens
354 has been observed, both in compression tests and during creep tests;
- 355 • long term strains do not reach an ultimate value, even when in stable loading; this
356 happens in particular at 1 day and 7 days of curing, less for 28 days of curing. The
357 balance between the maintained load and residual strengthening appears to be
358 reasonably the cause for the observed trend;
- 359 • strain creep diagrams show one half of final value occur in the initial 2 minutes; there
360 is an initial link with expected values after compression testing, then stiffness changes
361 as a consequence of induced damage. The load in creep tests, even if less than UCS,
362 is anyway applied instantly;
- 363 • in creep testing, for some specimens, failure has been observed as a progressive
364 trend towards unstable crack propagation;
- 365 • no absolute and unique link between measured settlements in creep and the
366 correspondent modulus of deformability in the compression test has been found;
367 however satisfactory correlations exist between ΔH_{final} in stable creep zones and E_s
368 75% from compression tests for 1 day and 28 days of curing; in a similar way,
369 correlation exists between $\Delta H_{primary}$ in creep and E_s 75% from compression tests for 7
370 days of curing;
- 371 • the deformative process results to be different for short grout curing age (1 day)
372 respect to 7 or 28 days of curing age;

- 373 • Although temperature has an effect on creep behavior for both rocks (Li et al., 2019)
374 and concrete (e.g. Geymayer, 1970) accelerating creep, its effects are beyond the
375 scope of this research.

376 The trend of deformations over time after 7 and 28 days of curing is interesting to evaluate
377 in order to study the effect of the creep of the two-component material on the behavior of
378 the support system.

379 In particular, after 7 days of curing it is useful to refer to the curve obtained by applying an
380 axial load equal to 33% of the failure stress (UCS) of the material (Fig. 9); this load did not
381 cause the material to fail and a final stabilization of deformations was observed. For applied
382 loads equal to 45% of UCS or higher (55% and 66%), on the other hand, the failure of the
383 material was achieved after a creep phase.

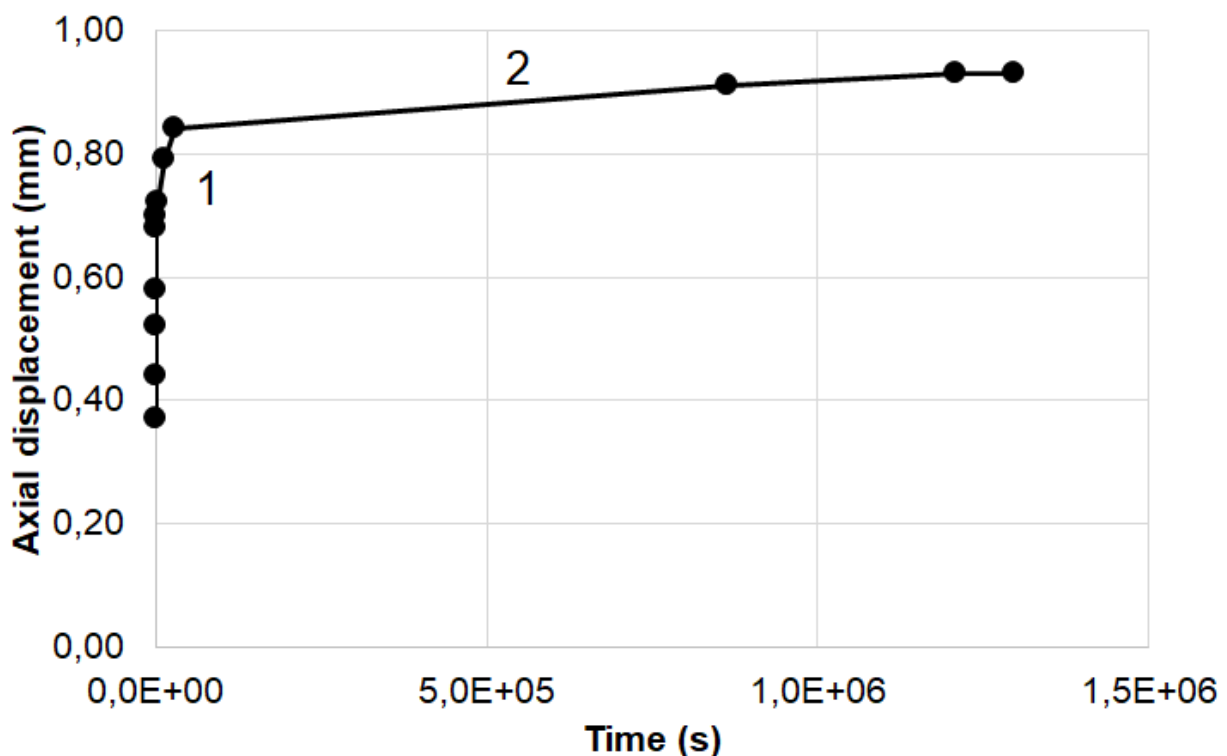

384
385 **Fig. 9. Trend of deformations over time in a sample of two-component material cured**
386 **for 7 days and subjected to an axial load equal to 33% of UCS. After the application**
387 **of the load, there is a significant increase in displacements in the first 10 minutes,**

388 **after which the displacements grow with a markedly bi-linear trend (zones 1 and 2 in**
389 **the graph) until stabilization is reached after about 14 days from loading.**

390 From the analysis of the figure it can be seen that the immediate displacement (δ_{inst}) upon
391 application of the load is 0.37 mm. In the first 10 minutes there is a significant increase in
392 the displacements until reaching a double value of δ_{inst} , after which the displacements
393 increase with a markedly bi-linear trend until stabilization is reached after about 14 days
394 from loading: in the first linear section, the displacement changes from $2.00 \cdot \delta_{inst}$ to $2.25 \cdot \delta_{inst}$
395 after 8 hours from the application of the load; in the second linear section it reaches a
396 displacement of $2.50 \cdot \delta_{inst}$ after 14 days from the application of the load. The expressions
397 that describe the trend of the displacements over time in the two linear sections are shown
398 below:

$$399 \quad \delta = [2.00 + 0.032 \cdot (t - 1/6)] \cdot \delta_{inst} \quad (t \text{ in hours}), \text{ for } t \text{ ranging between } 1/6 \text{ hours and } 8 \\ 400 \text{ hours} \quad (1)$$

$$401 \quad \delta = [2.25 + 0.018 \cdot (t - 1/3)] \cdot \delta_{inst} \quad (t \text{ in days}), \text{ for } t \text{ ranging between } 1/3 \text{ days and } 14 \text{ days} \\ 402 \quad (2)$$

403 After 28 days of curing, the specimen on which a load equal to 75% of the UCS value was
404 applied reached failure after the creep phase. While for loads equal to 35% and 55% of
405 UCS, there was no failure of the specimen subjected to the creep test. More specifically, for
406 the load equal to 35% of UCS we note the same bi-linear trend observed for the case
407 referred to the 7-day curing, with a value of δ_{inst} equal to 0.30 mm. While for the load equal
408 to 55% there is also a bi-linear trend but with the following characteristics: even now in the
409 first 10 minutes there is a significant increase in displacements until reaching a value of
410 $1.5 \cdot \delta_{inst}$; after which the displacements increase up to $1.75 \cdot \delta_{inst}$ after 8 hours from the
411 application of the load and in a second stretch up to the final stabilization at 14 days from
412 the application of the load with a final displacement value equal to $2 \cdot \delta_{inst}$.

413 From a detailed analysis of the results of the creep tests, therefore, the following can be
414 noted:

- 415 • the maximum percentage of the load with respect to UCS that would allow to avoid
416 the failure of the specimen in the long term goes from about 40 for 1 week of curing
417 of the material to about 70 for 4 weeks of curing of the specimen;
- 418 • the trend of deformations over time follows a bi-linear law after the first 10 minutes of
419 loading; a first stretch is between 10 minutes and 8 hours from the application of the
420 load, the second stretch from 8 hours to 14 days from the application of the load;
- 421 • the curing age of the specimen does not seem to alter the deformation curve over
422 time; a certain effect on this curve is given by the applied load, evaluated as a
423 percentage of the UCS value;
- 424 • the deformation increases according to two linear sections and the total value of the
425 creep strain is constant and equal to one half of the immediate deformation detected
426 on the specimen upon application of the load, regardless of the curing age of the
427 specimen and the percentage value of the applied load;
- 428 • in the first 10 minutes from the application of the load the deformations grow rapidly
429 until reaching 2 times the immediate deformation ($2 \cdot \delta_{inst}$) for percentages of the load
430 equal to about 35% of UCS and 1.5 times the immediate deformation ($1.5 \cdot \delta_{inst}$) for
431 percentages of the load equal to about 55% of UCS.

432 Immediate deformation therefore has a significant importance in understanding the
433 phenomenon of creep because it influences the deformation levels that develop in the
434 material over time. From the results obtained in the laboratory tests (uniaxial compression
435 and creep), it can be seen how the initial deformation can be estimated with a good
436 approximation by adopting the tangent elastic modulus determined in the uniaxial
437 compression tests, associated with the stress value equal to the applied load in the creep

438 test. Ultimately, if the applied load is equal to 35% of UCS, the immediate deformation of
439 the specimen ε_{inst} will be defined by the following relationship:

$$440 \quad \varepsilon_{inst} = \frac{0.35 \cdot UCS}{E_{t,35\%}} \quad (3)$$

441 where:

442 UCS is the monoaxial compressive strength of the two-component material measured for a
443 specific curing age;

444 $E_{t,35\%}$ is the tangent modulus of elasticity measured at a stress level equal to 35% of UCS,
445 evaluated on a specimen of two-component material with a specific curing age, subject to
446 the uniaxial compression test.

447 **Analysis of the effects of creep on the tunnel support system**

448 The support system (segmental lining with the two-component material surrounding it) has
449 been studied in detail by Oreste et al. (2021). Using the convergence-confinement method,
450 it is possible to analyze the interaction between this support system and the tunnel wall. It
451 is a very widespread analytical method in the geomechanical field, such as the limit
452 equilibrium method (LEM) (Oreste, 2013), which combines the advantage of the simplicity
453 of the approach with the precision and reliability of the results.

454 Some simplifying hypotheses are necessary (Osgoui and Oreste, 2007; Oreste, 2009a;
455 2009b; Ranjbarnia et al., 2014; 2016; Spagnoli et al., 2016):

- 456 • circular and deep tunnel;
- 457 • initial stress state of hydrostatic type ($k_0 = 1$);
- 458 • homogeneous and isotropic soil or rock, with linear elastic behavior.

459 Specific and detailed studies of the behavior of the support system can be developed by
460 adopting three-dimensional numerical modeling (Do et al., 2014; 2015a; 2015b; Pelizza et
461 al., 2000).

462 In order to evaluate the load applied on the segmental lining and the deformation conditions
463 of the tunnel wall and of the segmental lining, it is necessary to intersect the convergence-
464 confinement curve with the reaction line of the support system (Fig. 10) (Oreste, 2003).

465 The convergence-confinement curve depends on the behavior of the ground at the tunnel
466 boundary: it relates the internal pressure applied on the tunnel wall to the radial
467 displacement of the tunnel wall towards the center of the tunnel (Brown et al., 1983; Panet,
468 1995). As the internal pressure decreases, the radial displacement increases, until it reaches
469 the maximum value when the internal pressure is zero.

470 The reaction line of the support system relates the pressure applied by the support system
471 to the variation of the displacement of the tunnel wall. This displacement also corresponds
472 to the displacement manifested by the support system on its outer edge, which comes into
473 contact with the tunnel wall. As the movement of the tunnel wall increases, the pressure
474 applied by the tunnel wall will increase.

475 There is an end equilibrium point between the tunnel and the support system which is given
476 by the intersection between the convergence-confinement curve and the reaction line of the
477 support system.

478

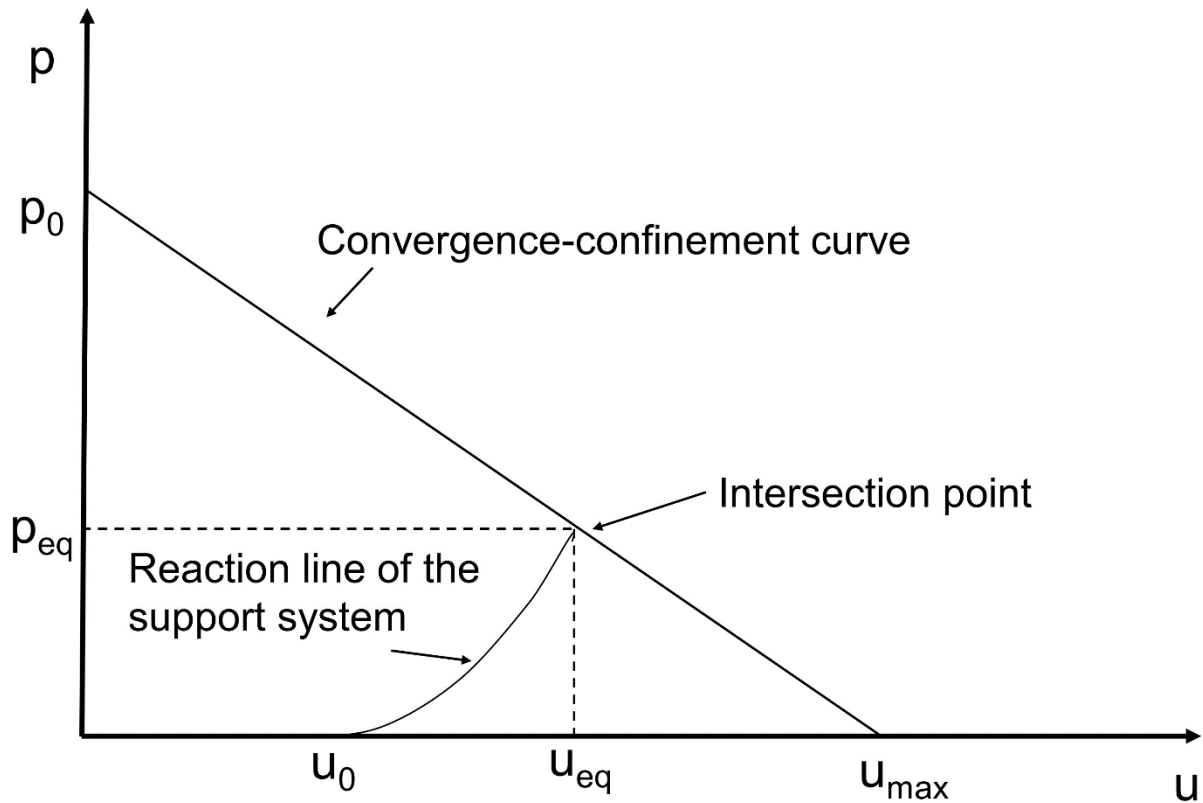

479

480 **Fig. 10** The intersection between the convergence-confinement curve of the tunnel
 481 **and the reaction line of the support system when this is composed of segmental lining**
 482 **and the two-component material around it (modified by Oreste et al., 2021). Legend:**
 483 **p : internal pressure applied to the tunnel wall; u : radial displacement of the tunnel**
 484 **wall; p_0 : lithostatic stress in the soil or rock at the depth of the tunnel; u_0 :**
 485 **displacement of the tunnel wall at the distance from the excavation face of the section**
 486 **where the support system is installed; $u_{max} = (1 + \nu_{gr}) \cdot p_0 \cdot R/E_{gr}$, where E_{gr} is the**
 487 **elastic modulus and ν_{gr} the Poisson's ratio of the ground (soil or rock) present around**
 488 **the tunnel; R is the tunnel radius; p_{eq} and u_{eq} : respectively the load applied on the**
 489 **support system and the radial displacement of the tunnel wall in the final condition**
 490 **of equilibrium, at the end of the process of loading the support system.**

491 An iterative procedure was developed to correctly describe the reaction line of the support
 492 system (Oreste et al., 2021). The curvilinear shape of the reaction line is due to the fact that

493 the two-component material matures during the loading of the support system. There will be
 494 two specific different stiffnesses of the support system: when the segmental lining is
 495 installed, the two-component material will have a very low initial stiffness (short curing age);
 496 at the end of the support loading process (when the excavation face has advanced to a
 497 distance of about $4 \cdot R$ from the study section), the stiffness of the two-component material
 498 reaches its maximum value. This different stiffness of the support system is reflected in the
 499 inclination of the curvilinear reaction line, which initially presents a lower tangent, until
 500 reaching the maximum inclination of the tangent line near the point of intersection with the
 501 convergence-confinement curve (end of the support system loading process).

502 The point of intersection is given by the values p_{eq} and u_{eq} respectively the load applied on
 503 the support system and the radial displacement of the tunnel wall in the final equilibrium
 504 condition. p_{eq} and u_{eq} can be obtained from the following expressions:

$$505 \quad u_{eq} = \frac{2 \cdot p_0 + u_0 \cdot (k_{sys,fin} + k_{sys,in})}{\frac{2 \cdot E_{gr}}{(1 + \nu_{gr}) \cdot R} + (k_{sys,fin} + k_{sys,in})} \quad (4)$$

$$506 \quad p_{eq} = p_0 - \frac{E_{gr}}{(1 + \nu_{gr}) \cdot R} \cdot u_{eq} \quad (5)$$

507 where:

508 $k_{sys,in}$ and $k_{sys,fin}$: stiffness of the support system at the beginning and at the end of the
 509 loading process; for the evaluation of the initial stiffness, reference is made to the curing age
 510 t_0 , necessary to resume the advancement of the TBM machine, which marks the start of
 511 loading of the lining; for the evaluation of the final stiffness, reference is made to the time
 512 (t_f) necessary for the excavation face to reach a distance of about $4 \cdot R$ from the studied
 513 section.

514 The overall stiffness of the support system is evaluated using the following equation (Oreste,
 515 2003; Oreste et al., 2021):

$$516 \quad k_{sys} = \frac{2 \cdot E_{fm} \cdot (1 - \nu_{fm}) \cdot R \cdot \left[\frac{E_{fm}}{(1 + \nu_{fm})} + (R - t_{fm}) \cdot k_{sl} \right]}{E_{fm} \cdot (1 - 2 \cdot \nu_{fm}) \cdot R^2 + (R - t_{fm})^2 \cdot \left[E_{fm} + (1 - 2 \cdot \nu_{fm}) \cdot (1 + \nu_{fm}) \cdot k_{sl} \cdot t_{fm} \cdot \left(1 + \frac{R}{(R - t_{fm})} \right) \right]} - \frac{E_{fm}}{(1 + \nu_{fm}) \cdot R} \quad (6)$$

517 where:

$$518 \quad k_{sl} = \frac{E_{sl}}{(1 + \nu_{sl})} \cdot \frac{(R - t_{fm})^2 - (R - t_{fm} - t_{sl})^2}{(1 - 2 \cdot \nu_{sl}) \cdot (R - t_{fm})^2 + (R - t_{fm} - t_{sl})^2} \cdot \frac{1}{(R - t_{fm})}$$

519 k_{sl} is the radial stiffness of the segmental lining;

520 E_{fm} and ν_{fm} are respectively the elastic modulus and the Poisson's ratio of the filling
521 material; E_{fm} varies over time with increasing curing age;

522 E_{sl} and ν_{sl} are respectively the elastic modulus and the Poisson's ratio of the segmental
523 lining;

524 t_{fm} and t_{sl} are respectively the thickness of the filling material and of the segmental lining.

525 To determine the k_{sys} values it is necessary to evaluate the elastic modulus of the filling
526 material E_{fm} . Imagining a progressive loading over time with a regular advancement of the
527 excavation face, the deformation process that develops in the filling material is the one that
528 refers to the first minutes of the creep tests.

529 Therefore, for the evaluation of the $k_{sys,in}$ reference must be made to the initial tangent
530 elastic modulus ($E_{fm} = E_{t,0\%}$ of the filling material). To determine $k_{sys,fin}$ a value of the elastic
531 modulus of the filling material must be adopted which depends on the stress level reached
532 inside it in the final equilibrium condition:

$$533 \quad E_{fm} \cong \frac{E_{t,\alpha}}{\omega} \quad (7)$$

534 where:

535 $E_{t,\alpha}$ is the tangent elastic modulus of the filling material associated with a percentage load
536 level α referred to UCS;

537 ω is a correction coefficient that takes into account the deformation increase that occurs in
538 the first 10 minutes of load in the creep test; it depends on the percentage α of the stress
539 level acting in the filling material with respect to the UCS strength, i.e. $\omega = 2.875 - 2.5 \cdot \alpha$.

540 Since the stress state induced in the filling material depends on the still unknown value of
541 p_{eq} , also in this case the value of E_{fm} must be adapted as a function of p_{eq} and u_{eq} , which
542 is obtained from the intersection of the two curves. Another iterative procedure is therefore
543 necessary.

544 The value of the maximum principal stress in the filling material can be obtained from the
545 following expression (Oreste et al., 2021):

$$546 \sigma_{1,max,fm} \cong \frac{u_{eq} \cdot \frac{E_{fm}(t_f) + E_{fm}(t_0)}{2 \cdot R} + (v_{fm} + v_{fm}^2) \cdot p_{eq}}{(1 - v_{fm}^2)} \quad (8)$$

547 where: $\sigma_{1,max,fm}$ is the maximum (circumferential) principal stress in the filling material.

548 The value α will be adapted until the values of p_{eq} , u_{eq} , $\sigma_{1,max,fm}$ and UCS are compatible
549 with each other. At that point, the reaction line of the support system can be correctly placed
550 in the graph and p_{eq} and u_{eq} evaluated.

551 Once the final configuration of the support system has been reached, it will be possible to
552 represent the effect of the creep on the bilinear tract of Fig. 9. On the basis of the
553 experimentation carried out and what was deduced in the previous paragraph, the overall
554 deformation increase due to the creep phenomenon can be estimated as half of the
555 immediate deformation, regardless of the curing age of the specimen and the value of the
556 applied load. It is therefore possible to derive the increase in deformation due to the creep
557 in the filling material from the following expression:

558
$$\varepsilon_{creep} = 0.5 \cdot \frac{\sigma_{1,max,fm}}{E_{t,\alpha}} \quad (9)$$

559 Since this deformation ε_{creep} is a circumferential deformation at the extrados of the filling
 560 material ring, it is possible to derive from it the increase in displacement Δu of the tunnel
 561 wall:

562
$$\Delta u = \varepsilon_{creep} \cdot R \quad (10)$$

563 Thanks to the knowledge of Δu it will be possible to represent the effect of the creep of the
 564 filling material on the graph of the convergence-confinement curve and evaluate the final
 565 displacement of the tunnel wall (Fig. 11).

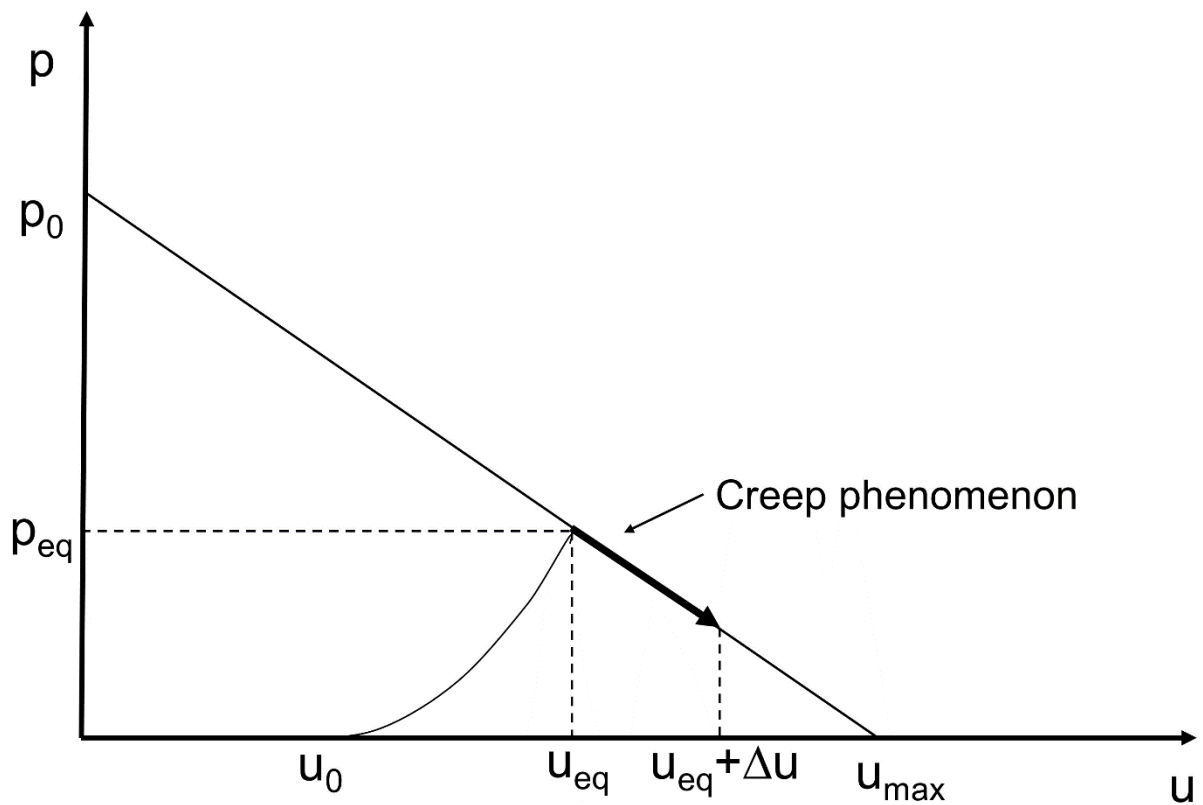

566
 567 **Fig. 11. Representation of the creep phenomenon in the filling material once the final**
 568 **equilibrium point is reached at the end of the process of placing the support system**
 569 **in charge. Legend: Δu : increase in the radial displacement of the tunnel wall due to**
 570 **the creep of the filling material.**

571 The creep phenomenon therefore produces an increase in the displacement of the tunnel
572 wall, as well as a stress discharge of the segmental lining. Both results are fundamental for
573 tunnel design. The increase in the displacement of the tunnel wall is useful for evaluating
574 the subsidence of the soil surface in the long term. The stress relief of the segmental lining
575 allows to obtain the correct value of the safety factor of the support system in the long term.
576 Furthermore, the increase in the displacement of the tunnel wall as a result of the creep can
577 lead to values exceeding the maximum acceptable limits, such as to indicate an incorrect
578 functioning of the tunnel-support system. The final control of this displacement in the tunnel
579 design stage, therefore, is essential to avoid excessive values which could lead to high risks
580 of instability of the tunnel.

581 **Example of support system design considering the filling material creep phenomenon**

582 In defining the thickness of the filling material and also the thickness of the segmental lining,
583 it is necessary to consider the evolution over time of the mechanical characteristics of the
584 filling material (following its curing) and the creep phenomenon. In fact, the curing over time
585 and the creep phenomenon markedly characterize the two-component material and
586 influence the loading of the support system. The final load acting on the segmental lining,
587 therefore, depends on the thickness of the filling material and on the methods of loading the
588 support system. Oreste et al. (2021) have already demonstrated how the thickness of the
589 filling material, the downtime of the TBM machine after the construction of the support
590 system, the average speed of advancement of the TBM after the stop of the TBM are all
591 elements that influence the stress state in the filling material and the load acting on the
592 support system.

593 More specifically, the case of a tunnel with a length of 5 km and a diameter of 9.4 m,
594 excavated at a depth of about 70 m ($p_0 = 1.12$ MPa) in Northern Italy by a TBM machine
595 (EPB type) in a weakly cohesive soil having an elastic modulus E_{gr} of 150 MPa and a

596 Poisson's ratio ν_{gr} of 0.3 was analyzed in detail. The thickness adopted for the segmental
 597 lining (t_{sl}) was 0.35 m, the thickness of the filling material (t_{fm}) was 0.15 m. For the
 598 segmental lining concrete, an elastic modulus E_{sl} of 30,000 MPa and a Poisson's ratio ν_{sl}
 599 of 0.15 were assumed.

600 Considering a still stand for the construction of a new lining ring of 1 hour at a distance of
 601 2.5 m from the excavation face and an average advancement speed of the TBM v of 0.35
 602 m/h, the reaction line of the reported support system is shown in Figure 12 (modified after
 603 Oreste et al., 2021).

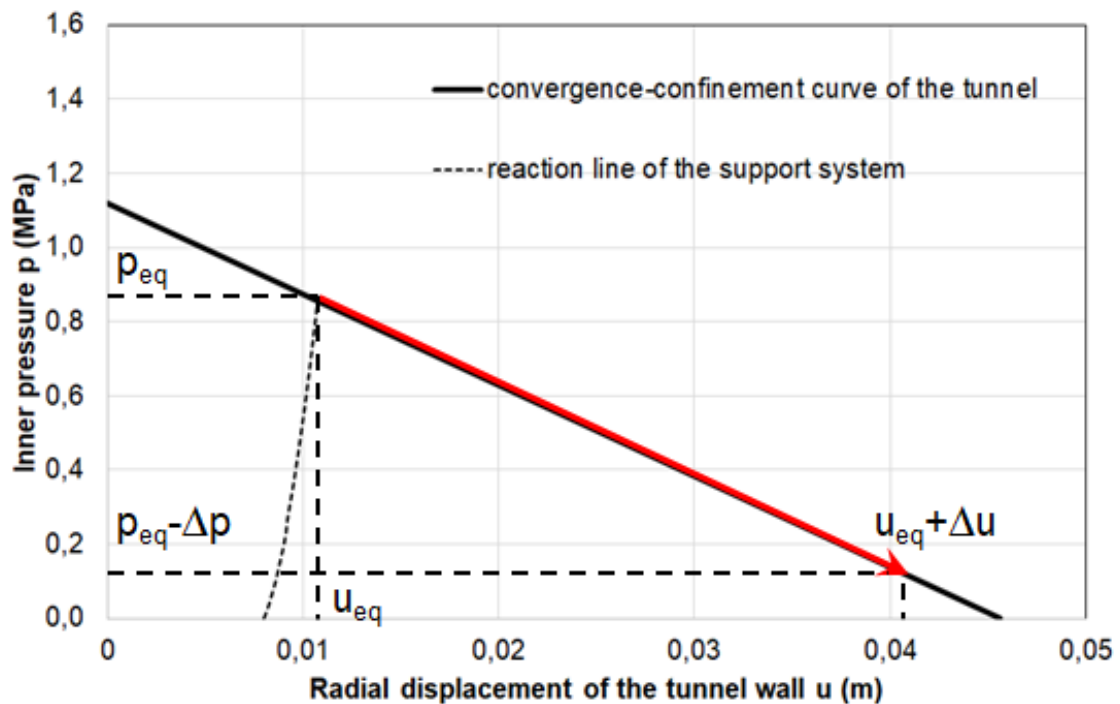

604

605 **Fig. 12. Convergence-confinement curve of the tunnel and reaction line of the support**
 606 **system in the examined case: tunnel with a diameter of 9.4 m at a depth of 70 m**
 607 **excavated in a weakly cohesive soil with an elastic modulus E_{gr} of 150 MPa. The**
 608 **support system consists of a 0.35 m thick segmental lining and a 0.15 m thick filling**
 609 **material ring. The red line represents the modification of the equilibrium point on the**

610 **convergence-confinement curve following the creep phenomenon in the filling**
611 **material.**

612 The pressure p_{eq} associated with the intersection point is 0.86 MPa and represents the load
613 acting on the support system at the end of the loading process, when the excavation face
614 reaches a distance of about $4 \cdot R$ from the study section of the support system. The
615 displacement u_{eq} is 10.7 mm: it is the final displacement of the tunnel wall at the end of the
616 loading process.

617 Using eq. 8 it is possible to determine $\sigma_{1,max,fm}$, the maximum (circumferential) principal
618 stress in the filling material at the end of the loading of the support system; a value of 0.92
619 MPa is obtained, which constitutes 31.6% of the strength of the material after about 48 h,
620 the average time necessary to reach the distance of $4 \cdot R$ from the investigated section.

621 From the experimental study developed and presented in the previous paragraphs, it was
622 possible to verify how the long-term strength of the two-component material is only a
623 percentage η of the UCS. In particular, the value of η depends on the days of curing of the
624 material:

$$625 \quad \eta \cong 0.3 + 0.0143 \cdot t_c \quad (11)$$

626 Where:

627 t_c is the curing age in days.

628 After two days of curing (48 h), therefore, η worth about 32.9%. This means, therefore, that
629 a maximum stress of 0.92 MPa (31.6% of the compressive strength UCS) is bearable by the
630 two-component material even in the long term without reaching failure. By maintaining its
631 integrity, the two-component material is able to effectively perform the task of transferring

632 the radial loads to the segmental lining and allowing the support system to be waterproofed,
633 preventing water from infiltrating inside the tunnel.

634 As for the deformation increase of the tunnel wall, the value of Δu can be determined on the
635 basis of equations 9 and 10 and considering that the stress $\sigma_{1,max,fm}$ inside the two-
636 component material tends to decrease progressively during the creep phase: it is therefore
637 necessary to adopt the average value that this stress assumes in this specific phase.
638 Therefore, assuming a tangent elastic modulus E_t at two days of curing equal to 40 MPa,
639 we obtain a ε_{creep} value of 0.0067 and an increase in the radial displacement of the tunnel
640 wall of about 31 mm. This increase in the deformations of the tunnel wall has the effect of
641 reducing the load applied on the segmental lining from the initial value of 0.86 MPa to the
642 final value (at the end of the creep phase) of 0.11 MPa. A consistent reduction of the acting
643 loads and of the stress state induced in the concrete which is often found when detailed
644 measures for monitoring the behavior of the segmental lining are available long times after
645 its installation.

646 **Conclusions**

647 The filling material inserted in the gap between the segmental lining and the tunnel wall has
648 several important roles aimed at ensuring the effectiveness of the support system of a tunnel
649 excavated with a TBM machine. Nowadays a **bi**-component filling material is widely used,
650 which has particular characteristics: a curing phase during which the mechanical parameters
651 evolve rapidly; a creep behavior with secondary deformations that develop over time when
652 the material is subjected to a stress load. These features make the interaction between the
653 support system and the tunnel complex, given that the filling material is loaded progressively
654 over time, starting from its installation into the gap between the segmental lining and the
655 tunnel wall. The creep phase generally comes into play at the end of the support system

656 loading phase and has as a consequence the reduction of the loads transmitted to the
657 segmental lining and the increase in deformations of the tunnel wall.

658 The creep phenomenon has been studied for many other materials in the field of
659 geotechnics and geomechanics. Many models have been developed and are known in the
660 scientific literature to represent the behavior of such materials. Although the two effects
661 mentioned above and induced by the creep of the filling material on the extrados of the
662 segmental lining are very important, no studies on this topic are available in the literature.

663 In particular, the increase in the radial displacement of the tunnel wall due to the
664 phenomenon of creep in the filling material can induce high subsidence on the soil surface
665 and can lead to conditions that are not compatible with the stability of the tunnel (exceeding
666 the maximum permissible values of the convergence tunnel).

667 In this work the results of an extensive laboratory experimentation on the creep behavior,
668 developed for different curing ages of the specimens and different load entities in relation to
669 the UCS of the material, are reported. It was possible to identify which is the maximum
670 compression stress where no failure of the material under a continuous load over time is
671 observed. In addition, it was possible to derive the recurring trend of deformations over time
672 (creep trend) by varying the curing ages and the stress state applied to the specimens.

673 The information obtained from the experimentation was then used to understand the effects
674 of the creep phase of the two-component material on the interaction between the support
675 system and the tunnel. In particular, it was possible to evaluate the decrease in the radial
676 load applied to the support system (and, therefore, to the segmental lining) and the increase
677 in the deformations of the tunnel wall. Finally, the application of the above considerations to
678 a real case of a tunnel excavated in Northern Italy in a weakly cohesive ground has allowed
679 to understand how the creep of the two-component material has non-negligible effects on

680 the final stress state induced in the segmental lining and on radial displacements of the
681 tunnel wall.

682 **Acknowledgment**

683 The authors wish to thank Master Builders Solutions by MBCC Group for the permission
684 granted to publish the results **and to the reviewers' comments which increased the quality**
685 **of the manuscript.**

686 **Conflict of interests**

687 Authors declare they have no conflict of interest.

688 **References**

689 Arnau, O., Molins, C., Blom, C.B.M., Walraven, J. (2011). Longitudinal time-dependent
690 response of segmental tunnel linings. *Tunnelling and Underground Space Technology*
691 *28(1):98, 10.1016/j.tust.2011.10.002.*

692 Barla, G. (2011). Contributions to the understanding of time dependent behaviour in deep
693 tunnels. *Geomech Tunnelling*; 4: 255-264.

694 **Brown E.T., Bray J.W., Ladanyi B., Hoek E. (1983). Ground response curves for rock**
695 **tunnels. Journal of Geotechnical Engineering,109, 1, 15-39**
696 **[https://doi.org/10.1061/\(ASCE\)0733-9410\(1983\)109:1\(15\)](https://doi.org/10.1061/(ASCE)0733-9410(1983)109:1(15)**

697 **Cardu, M. and Oreste, P. (2012). Technical-operational comparison between trench-cutters**
698 **and clam excavators for concrete diaphragm construction in underground works at shallow**
699 **depths. Int. J. Min. Reclamat. Environ., 26, 3, 217–232.**

700 Di Giulio, A., Bavasso, I., Di Felice, M., and Sebastiani, D. (2020). A preliminary study of the
701 parameters influencing the performance of two-component backfill grout. *Gallerie e Grandi*
702 *Opere Sotteranee. 133. 11-17.*

703 Do N.A., Dias D., Oreste P. (2014). Three-dimensional numerical simulation of mechanized
704 twin stacked tunnels in soft ground, *Journal of Zhejiang University: Science A*, 15(11):896–
705 913.

706 Do N.A., Dias D., Oreste P., Djeran-Maigre I. (2015a). 2D numerical investigation of
707 segmental tunnel lining under seismic loading. *Soil Dynamics and Earthquake Engineering*
708 72 (2015): 66-76.

709 Do N.A., Dias D., Oreste P. (2015b). 3D numerical investigation on the interaction between
710 mechanized twin tunnels in soft ground. *Environmental Earth Sciences*, 73(5):2101–2113.

711 Dusseault. M.B. Fordham. C.J. 1993. Time-dependent behavior of rocks. In Hudson JA. ed.
712 *Comprehensive Rock Engineering*. Pergamon Press: 119–149.

713 Farmer I.W. and Gilbert M.J. (1981). Time dependent strength reduction of rock salt. Proc.
714 1st Conf. on Mechanical Behaviour of Rock Salt, Pennsylvania State Univ.

715 Flores, A.Q. (2015). Physical and mechanical behavior of a two component cement-based
716 grout for mechanized tunneling application. MSc Thesis. Universidade Federal do Rio de
717 Janeiro. Brazil.

718 **Geymayer, H.G. (1970). The effect of temperature on creep of concrete: a literature review.**
719 **U.S. Army Engineer Waterways Experiment Station Corps of Engineers, Vicksburg,**
720 **Mississippi.**

721 Goodman, R. (1980). *Introduction to Rock Mechanics*. New York: Wiley.

722 Griggs, D. (1939). Creep of rocks. *The Journal of Geology*, 47, 3, 225-251.

723 Hardy H.R., Kim R.Y., Stefanko R. and Wang Y.J. (1969). Creep and microseismic activity
724 in geologic materials. Proc. 13th US Rock Mech. Symp., Berkeley, 377-413.

725 Hirata, T. (1989). Study on behavior of cohesive soil in type shield tunneling work and on
726 construction technique. Doctoral Thesis. Kyoto University. Japan.

727 Huber, H.G. (1991). Untersuchung zum Verformungsverhalten von jungem Spritzbeton im
728 Tunnelbau. Master Thesis. University of Innsbruck. Austria.

729 Jaeger, J.C.. Cook. N.G.W. (1979). Fundamentals of Rock Mechanics. London: Chapman
730 and Hall.

731 Kuwajima, F.M. Early age properties of the shotcrete. In Shotcrete for Underground VIII.
732 Celestino. T.B. and Parker. H.W.. eds.. Conference Eighth International Conference. São
733 Paulo. Brazil, April 11-15. 1999. American Society of Civil Engineers. Reston. VA.

734 Lama R.D. and Vutukuri V.S. (1978). Handbook on mechanical properties of rock. Testing
735 techniques and results. Vol. III, Trans Tech Publ.

736 Li., J., Sun. G., Zou, H., Zhou, Z., Fan, X. (2019). Influence of temperature and load on creep
737 characteristics of soft rock similar materials. IOP Conf. Series: Earth and Environmental
738 Science 384, 012229, doi:10.1088/1755-1315/384/1/012229.

739 Melbye, T. (1994). Sprayed Concrete for Rock Support. Switzerland: MBT Underground
740 Construction Group.

741 Ochmański, M.. Modoni, G. and Bzówka, J. (2018). Automated numerical modelling for the
742 control of EPB technology. Tunnelling and Underground Space Technology 75. 117–128.
743 <https://doi.org/10.1016/j.tust.2018.02.006>.

744 Ochmański, M., Modoni. G. and Spagnoli, G. (2021). Influence of the annulus grout on the
745 soil-lining interaction for EBP tunneling. Geotechnical Aspects of Underground Construction
746 in Soft Ground: Proceedings of the Tenth International Symposium on Geotechnical Aspects
747 of Underground Construction in Soft Ground, IS-Cambridge 2022, Cambridge, United
748 Kingdom, 27-29 June 2022, 350-356, DOI: 10.1201/9780429321559-45

749 Oggeri, C.. Oreste, P.. and Spagnoli, G. (2021). The influence of the two-component grout
750 on the behaviour of a segmental lining in tunnelling. Tunnelling and Underground Space
751 Technology. 109. 103750. <https://doi.org/10.1016/j.tust.2020.103750>.

752 Oh, J.Y. and Ziegler, M. (2014). Investigation on influence of tail void grouting on the surface
753 settlements during shield tunneling using a stress-pore pressure coupled analysis. KSCE
754 Journal of Civil Engineering. 18(3). 803-811. DOI: 10.1007/s12205-014-1383-8.

755 Oreste P. (2003). Analysis of structural interaction in tunnels using the convergence–
756 confinement approach, *Tunnelling and Underground Space Technology*, 18, 4, 347-363.

757 Oreste, P. (2007). A numerical approach to the hyperstatic reaction method for the
758 dimensioning of tunnel supports. *Tunnelling and Underground Space Technology*
759 22(2):185–205. <https://doi.org/10.1016/j.tust.2006.05.002>.

760 Oreste P (2009a). The convergence-confinement method: roles and limits in modern
761 geomechanical tunnel design. *American Journal of Applied Sciences* 6(4):757-771.

762 Oreste P (2009b). Face stabilisation of shallow tunnels using fibreglass dowels. *Proceedings*
763 *of the Institution of Civil Engineers-Geotechnical Engineering*, 162(2):95-109.

764 Oreste P. (2013). Face stabilization of deep tunnels using longitudinal fibreglass dowels.
765 *International Journal of Rock Mechanics and Mining Sciences*, 58:127-140.

766 Oreste P (2015). Analysis of the interaction between the lining of a TBM tunnel and the
767 ground using the convergence-confinement method. *American Journal of Applied Sciences*
768 12(4):276-283. DOI: 10.3844/ajassp.2015.276.283.

769 Oreste P., Spagnoli G., Ceravolo LA (2019) A numerical model to assess the creep of
770 shotcrete linings. *Proceedings of the Institution of Civil Engineers – Geotechnical*
771 *Engineering*. 172. 4. 344-354. <https://doi.org/10.1680/jgeen.18.00089>.

772 Oreste, P., Spagnoli, G., Luna Ramos, C.A. (2020). Evaluation of the safety factors of
773 shotcrete linings during the creep stage. *Proceedings of the Institution of Civil Engineers –*
774 *Geotechnical Engineering*. 173. 3. 274-282. <https://doi.org/10.1680/jgeen.19.00104>

775 Oreste, P., Sebastiani, D., Spagnoli, G., de Lillis, A. (2021) Analysis of the behavior of the
776 two-component grout around a tunnel segmental lining on the basis of experimental results
777 and analytical approaches. *Transportation Geotechnics*, 29, 100570,
778 <https://doi.org/10.1016/j.trgeo.2021.100570>

779 Orumchi, H. and Mojallal, M. (2017). Shear Strength Design of a Mechanized Tunneling
780 Grout Mix: Case Study of the Tehran Subway Line 6 Project. *Transp. Infrastruct. Geotech.*
781 4, 18–36. <https://doi.org/10.1007/s40515-017-0037-7>

782 Osgoui, R., and Oreste, P. (2007). Convergence-control approach for rock tunnels
783 reinforced by grouted bolts, using the homogenization concept. *Geotechnical and*
784 *Geological Engineering* 25(4):431-440, DOI: [10.1007/s10706-007-9120-0](https://doi.org/10.1007/s10706-007-9120-0).

785 **Panet, M. (1995). *Calcul des Tunnels par la Methode de ConvergenceConfinement*. Paris:**
786 **Press de l'Ecole Nationale des Ponts et Chausses.**

787 Pelizza S., Oreste P., Peila D., Oggeri C. (2000). Stability analysis of a large cavern in Italy
788 for quarrying exploitation of a pink marble. *Tunnelling and Underground Space Technology*,
789 15(4):421–435.

790 Price A.M. and Farmer I.W. (1981). The Hvorslev surface in rock deformation. *Int. Journ. Of*
791 *Rock Mech. And Min.Sci.*, 18, 229-34.

792 Ranjbarnia M., Fahimifar A., Oreste P. (2014). A simplified model to study the behavior of
793 pre-tensioned fully grouted bolts around tunnels and to analyze the more important
794 influencing parameters. *Journal of Mining Science* 50(3):533-548

795 Ranjbarnia, M., Fahimifar, A., Oreste, P. (2016). Practical method for the design of
796 pretensioned fully grouted rockbolts in tunnels. *International Journal of Geomechanics*,
797 16(1), 04015012

798 Rahmati, S., Chakeri. H., Sharghi. M., Dias, D. 2021. Experimental study of the mechanical
799 properties of two-component backfilling grout. *Proceedings of the Institution of Civil*
800 *Engineers - Ground Improvement*. <https://doi.org/10.1680/jgrim.20.00037>.

801 Rokahr, R.B. Lux, K.H. (1987). Einfluss des rheologischen Verhaltens des Spritzbetons auf
802 den Ausbauwiderstand. *Felsbau*. 5:11-18.

803 Shah, R., Lavasan, A.A., Peila, D., Todaro, C., Luciani, A. and Schanz, T. (2018). Numerical
804 study on backfilling the tail void using a two-component grout. *J. Mater. Civ. Eng.*, 30(3):
805 04018003.

806 Sharghi, M., Chakeri, H., Afshin, H., and Ozcelik, Y. 2018. An experimental study of the
807 performance of two-component backfilling grout used behind the segmental lining of a
808 Tunnel-Boring Machine. *Journal of Testing and Evaluation*, 46, 5, 2083–2099.
809 <https://doi.org/10.1520/JTE20160617>.

810 Spagnoli G., Oreste P., Lo Bianco L. (2016). New equations for estimating radial loads on
811 deep shaft linings in weak rocks. *International Journal of Geomechanics* 16(6): 06016006.
812 DOI: [10.1061/\(ASCE\)GM.1943-5622.0000657](https://doi.org/10.1061/(ASCE)GM.1943-5622.0000657).

813 Spagnoli G., Miedema S.A., Herrmann, C., Rongau J., Weixler, L., Denegre J. (2016)
814 Preliminary Design of a Trench Cutter System for Deep-Sea Mining Applications Under
815 Hyperbaric Conditions. *IEEE Journal of Oceanic Engineering* 41, 4, 930 – 943,
816 [10.1109/JOE.2015.2497884](https://doi.org/10.1109/JOE.2015.2497884).

817 Thewes, M. and Budach, C. (2009). Grouting of the annular gap in shield tunnelling-An
818 important factor for minimisation of settlements and production performance. *Proceedings*
819 *of the ITA-AITES World Tunnel Congress 2009 “Safe Tunnelling for the City and*
820 *Environment”*. pp. 1–9.

821 Thomas, A. (2009). *Sprayed concrete lined tunnels*. Oxon: Taylor and Francis.

822 Todaro, C., Peila, L., Luciani, A., Carigi, A., Martinelli, D. and Boscaro, A. (2019). Two
823 component backfilling in shield tunneling: laboratory procedure and results of a test
824 campaign. In *Proceedings of the WTC 2019 ITA-AITES World Tunnel Congress (WTC*
825 *2019)*. May 3-9, 2019. Naples, Italy. Peila, D., Viggiani, G. and Celestino, T. (eds). CRC
826 Press, Boca Raton.

827 Van der Schyff J.J. (2017). Quantifying the creep behaviour of polyester resin and grout.
828 Proceedings of the 17th Coal Operators' Conference, Mining Engineering, University of
829 Wollongong.

830 Yin, J. (1996). Untersuchungen zum zeitabhängigen Tragverhalten von tiefliegenden
831 Hohlräumen im Fels mit Spritzbeton. PhD Thesis. Clausthal University of Technology.
832 Germany.

833 Yu, C.W. 1998. Creep characteristics of soft rock and modelling of creep in tunnel:
834 determination of creep characteristics of soft rock and development of non-linear creep
835 analysis code for squeezing tunnel problem. PhD Thesis. University of Bradford. UK.