

Implementing Time-of-Use Demand Response Program in microgrid considering energy storage unit participation and different capacities of installed wind power

*Original*

Implementing Time-of-Use Demand Response Program in microgrid considering energy storage unit participation and different capacities of installed wind power / Hosseiniimani, S., Payam, N., M. R., B.. - In: ELECTRIC POWER SYSTEMS RESEARCH. - ISSN 0378-7796. - ELETTRONICO. - 175:(2019), p. 105916. [10.1016/j.epsr.2019.105916]

*Availability:*

This version is available at: 11583/2927968 since: 2021-10-11T10:29:48Z

*Publisher:*

Elsevier

*Published*

DOI:10.1016/j.epsr.2019.105916

*Terms of use:*

This article is made available under terms and conditions as specified in the corresponding bibliographic description in the repository

*Publisher copyright*

Elsevier postprint/Author's Accepted Manuscript

© 2019. This manuscript version is made available under the CC-BY-NC-ND 4.0 license  
<http://creativecommons.org/licenses/by-nc-nd/4.0/>. The final authenticated version is available online at:  
<http://dx.doi.org/10.1016/j.epsr.2019.105916>

(Article begins on next page)

# Implementing Time-of-Use Demand Response Program in Microgrid Considering Energy Storage Unit Participation and Different Capacities of Installed Wind Power

Mahmood Hosseini Imani <sup>\*</sup>, Payam Niknejad <sup>‡</sup>, M.R. Barzegaran <sup>†</sup>

<sup>\*</sup> Department of Energy, Politecnico di Torino, Turin, Italy

<sup>‡†</sup> Department of Electrical Engineering, Lamar University, Beaumont, TX, USA

<sup>\*</sup>Email: mahmood.hosseiniimani@polito.it

<sup>‡</sup> Email: pniknejad@lamar.edu

<sup>†</sup>Email: barzegaran@lamar.edu

## Abstract

Penetration of wind units in Microgrid (MG) imposes remarkable challenges on MG operation. Demand Response Programs (DRPs) and Energy Storage Units are used by MG operators to address these challenges. This paper analyzes the effect of running the Time-of-Use Demand Response Program (TOU-DRP) on an isolated MG by considering different capacities of installed wind power with/without energy storage unit. The energy storage unit is deployed to cover the stochastic nature of wind generation unit. TOU-DRP is modeled based on price elasticity and customer benefit function in an isolated MG. Different levels of customers' participation in TOU-DRP has also been studied and its effects on operation cost, unserved energy, and wind power spillage are investigated comprehensively. To verify the proposed model's efficiency, it is implemented on an 11-bus MG over a 24-hour period for twelve detailed case studies. The case study results confirmed the effectiveness of the proposed model in running DRP and providing MG operator a general overview for optimal operation.

## Index Terms

Microgrid, Time-of-Use Demand Response Program (TOU-DRP), Price Elasticity, Wind Power, Operation Cost.

## NOMENCLATURE

### ***Subscripts***

$b$	Index of battery
$i, j$	Index of bus
$s$	Index of scenario
$t$	Index of time
$z$	Index of the time period

### ***Parameters and Variables***

$a_{mt}, b_{mt}$	Coefficients of cost of Micro-turbines (MTs)
$C_{bat}$	The charging or discharging cost of battery
$d_z, d_{z'}$	Load demand in period $z$ and $z'$
$DR_{i,t,s}^-$	Load reduction at bus $i$ at time $t$ and scenario $s$
$DR_{i,t,s}^+$	Shifted load to an off-peak hour at bus $i$ at time $t$ and scenario $s$
$D_{i,z,s}, D_{i,z',s}$	Total load of bus $i$ of the $z^{\text{th}}$ and $z'^{\text{th}}$ period
$E_{zz}$	Self-elasticity of period $z$
$E_{zz'}$	Cross-elasticity of period $z$ to period $z'$
$E_{z'z'}$	Self-elasticity of period $z'$
$E_{b,t,s}^B$	Remaining capacity (battery energy) at time $t$ and scenario $s$
$E_b^{B,min}$	Minimum permissible battery capacity
$E_b^{B,max}$	Maximum permissible battery capacity
$IDR$	Set of customers that participated in the DRP
$LS_{i,t,s}$	Unsupplied load at time $t$ and scenario $s$ at bus $i$
$MT_i$	Micro-turbines (MTs) connected to bus $i$
$N_{mt}$	Number of Micro-turbines (MTs)
$N_{bat}$	Number of batteries
$N_i$	Number of buses
$NS$	Number of scenarios
$NT$	The time period of DRP
$NZ$	Number of periods (Zones)
$P_{b,t,s}^B$	Power generation of battery $b$ at time $t$ and scenario $s$
$P_{mt,t,s}^{MT}$	The MT production power at time $t$ and scenario $s$
$P_{mt}^{MT,min}, P_{mt}^{MT,max}$	The maximum and minimum power generation of MTs
$P_{i,t,s}^D$	The amount of load at bus $i$ at time $t$ and scenario $s$
$P_{pv,t,s}^{PV}$	Power generation of solar units at time $t$ and scenario $s$
$P_{pv,t,s}^{PV,forecast}$	The maximum base predicted power generation of solar units, at time $t$ and scenario $s$
$P_{w,t,s}^W$	Generated power of wind unit $w$ at time $t$ and scenario $s$
$P_{w,t,s}^{W,forecast}$	The maximum base predicted power generation of wind units, at time $t$ and scenario $s$

$P_{b,t,s}^B$	Generated power of battery $b$ at time $t$ and scenario $s$
$P_{b,t,s}^{ch}$	Charging power at time $t$ and scenario $s$
$P_{b,t,s}^{dc}$	Discharging power at time $t$ and scenario $s$
$P_b^{ch,min}, P_b^{ch,max}$	Minimum and maximum charge rate of the batteries
$P_b^{dc,min}, P_b^{dc,max}$	Minimum and maximum discharge rate of the batteries
$PL_{i,j,t,s}$	The transferred active power by each transmission lines (from bus $i$ to $j$ )
$q$	Customer demand (kWh)
$q_0$	Initial demand (kWh)
$q_z, q_{z'}$	Customer demand of period $z$ and period $z'$ (kWh)
$S_{w,t,s}^W$	Power generation spilled from wind unit $w$ at time $t$ and scenario $s$
$T_z, T_{z'}$	Sets of times related to period $z$ and period $z'$ where $T_z \cap T_{z'} = \emptyset$ if $z \neq z'$ .
$u_{mt,t,s}$	The binary variable that shows the on/off state of MT at time $t$ and scenario $s$
$u_{b,t,s}^{ch}$	Binary variables indicating the battery in charging mode
$u_{b,t,s}^{dc}$	Binary variables indicating the battery in discharging mode
$VOLL_{i,t}$	Penalty for unsupplied load
$Z_t$	$Z^{\text{th}}$ period related to hour $t$
$S_z$	Customer's profit in period $z$
$\pi_s$	Probability of scenario $s$
$\Delta d_z$	Amount of customer's load that changed by the customer
$\rho_{0z}, \rho_{0z'}$	Initial electricity energy (cent/kWh)
$\rho$	Electricity energy price (cent/kWh)
$\rho_z, \rho_{z'}$	Electricity energy price (cent/kWh)
$\rho_t$	Electric energy price of the grid (cent/kWh)
$\eta_b^{ch}, \eta_b^{dc}$	The charge and discharge efficiency of the battery storage system

## 1 INTRODUCTION

Employing Distributed Energy Resources (DERs), particularly in distribution networks, initiates numerous issues such as disrupting the control and operation of these networks. While using DERs can decrease operation cost, the control and operation of multiple small generation units with different operating characteristics lead to additional challenges in the safe and secure operation of the power grid [1]. To overcome these challenges, the concept of microgrids (MGs) is suggested.

MGs consist of traditional and renewable energy power plants, storages and controllable loads and a control/management system [2]. MGs can be operated independently in standalone modes with different objective functions which are widely studied in the literature. [1,3].

MG operator aims to find the optimal operation mode for the next day/days, reduce network costs, and predict DERs generation and system demand. In [4], the problem of MG daily scheduling is solved based on maximizing the use of local resources to supply the MG demand. To do so, the operator minimizes the MG operation cost considering the cost of DERs and the market price at a specified time period. Service scheduling of the energy generation and storage unit of an MG with PV sources is performed in [5]. In [6,7] the purpose of controlling charge and discharge modes of the energy storage systems is to maintain the power balance in MG. The oscillation of the generated power during the MG load shedding process is considered in [8] where a two-stage stochastic objective function is proposed to minimize the expected operation cost. Renewable energy prediction errors are compensated by responsive loads and DERs.

Demand Response (DR) is one of the well-known concepts that is developed with advances in MG operation. Based on the United States Department of Energy (DOE) definition, DR is "Changing consumers' energy consumption patterns in response to change in the price of electricity over time; or economic programs designed to encourage not using electricity during times when the price is high or the dependability of the network is jeopardized" [9]. DRPs are appropriate choices to reduce the power demands during critical times which consequently diminishes the operation cost [10, 11]. The DRPs with increased customer participation and system decentralization play crucial roles in enabling Distributed Generation (DG) by utilizing Energy Storage Systems (ESS) and alternate energy sources such as wind and solar energy. These generation resources, when coupled with DRP, present a sustainable system with reduced unserved energy and flexible operational characteristics. In [10], different mathematical models for Time-of-Use (TOU) programs are extracted and a comparison is performed to find the best model in terms of load curve characteristics. A DRP based on Time-of-Use (TOU) is proposed in [12] to overcome the challenges of optimal pricing during different time periods. This optimal pricing is fulfilled through minimum cost determination with the help of dynamic economic dispatch. In [13], the authors used TOU-based DR to increase the retailers' profit and reduce their risks associated with the uncertain nature of wholesale spot electricity market prices, while keeping their retail prices as low as possible. An EDRP (Emergency DRP) and TOU-based DR approach are employed in [14,15] to maximize customer's benefits. However, the total operating cost minimization is not considered as an objective function of the

day-ahead operation.

Two major categories of DR programs i.e. incentive-based and time-based programs are applied to the MG operation in [16,17]. A model has been proposed to be used by the operator to prioritize different DRPs. Multiple models and objective functions for running DRP in MG operation are proposed in the literature. In [18], The importance of DRP in the isolated operation mode of the MG have been summarized. The impacts of using DRP in a conventional grid is then compared with its heightened role in an MG setup with DER integration. A Direct Load Control DRP (DLC-DRP) for an upgrid-connected MG is proposed in [19] where power distribution company can control customer's power consumption by a remotely controlled switch and cut or postpone their power to cover the system incidents in exchange for an incentive for their contribution. In [20] an optimization method is proposed for the participation of a DER aggregator involving both DRP and generation resources. A price-based DR (PBDR) model is suggested in [21] to mitigate the difficulties of MG energy management in the presence of uncertain DG units and load demand. However, the time-based programs are not investigated in detail. Several packages of price strategy for DR implementation are offered in [22] to minimize the operating costs and emissions in the presence of uncertain wind and solar generations. The impact of customers' participation level and various incentive values on implementing DRPs in MG operation is investigated in [23] in which the significant sources in the islanded part of the network are wind and solar. The MG energy management in a market structure has been studied in [24] where the concept of aggregators and MG interaction has been considered in the form of an optimal DRP model. The economic performance of DRP integrated with the battery energy storage system (BESS) for MG operations is evaluated in [25,26]. A strategy is also proposed to find the optimal sizing of BESSs. The authors have claimed that the proposed model reduces operating and maintenance costs. The energy and reserve scheduling of an MG with variable wind power and load forecasts are studied in In [27]. Different kinds of consumers participate in energy scheduling by providing their price-quantity pair in DRP. However, the author did not consider simultaneous MG operation and running TOU-DRP based on price elasticity and customer benefit function. Modeling the energy storage systems in the simultaneous scheduling of MG and DR is discussed in [28] to address uncertainties associated with load demand, real-time electricity price, and the wind

power generation. But the battery contribution as a DG unit and its impact on operation factors is not studied in the abovementioned studies.

In this paper, the TOU-DRP is implemented in an isolated MG operation and the impact of the different capacities of installed wind power with/without the presence of battery is studied. It's extended work of authors' previous article [19] that considers the time factor in DRP and limits the impacts of upgrid's price by operating the MG in isolated mode. In this paper, customers don't receive any incentive for their contribution. The eligible customers adjust their consumption according to the time-based rates and shift their loads to off-peak hours to reduce MG's peak demand. The effects of different participation levels of customers on operation cost, unserved energy, and wind power spillage, which were not considered in previous work, are investigated thoroughly in TOU-DRP. The main contributions of this paper are as follows:

- The TOU-DRP is implemented in MG operation based on the price elasticity of demand and customer benefit.
- The impact of increased wind power penetration with/without using the battery in running TOU-DRP for MG operation is studied.
- Customers' participation level is considered in running TOU-DRP for MG operation and its effect is investigated on operation cost, unserved energy, and wind power spillage.
- The economic dispatch and unit commitment problems in MG operation is solved by using AC power flow with the aim of minimizing the operation cost as a result of implementing TOU-DRP.

The rest of the paper is organized as follows. Section 2 presents the TOU-DRP and its modeling detail. Section 3 details the model proposed for MG operation along with DRPs. Numerical analysis, simulation, and corresponding results are presented in section 4 and finally, section 5 concludes the paper.

## **2 TIME-OF-USE DEMAND RESPONSE PROGRAM (TOU-DRP)**

As a common definition, DRP is the participation of end-users in the electricity market operation in

response to time-based price changes and/or received financial incentives [29]. DRPs fall into two general categories of Incentive-Based Programs (IBPs) and Time-Based Programs (TBPs) where each group has several subgroups [14]. In this article, the TOU-DRP which is a time-based DRP is selected to be used in MG operation. By implementing this program, customers who can reduce or shift their electricity usage, adjust their consumption according to the time-based rates and shift their loads from peak hours to off-peak hours to reduce MG's peak demand.

In TOU-DRP, the energy price is variable and directly proportional to the MG load. The energy price is low in low load periods and it reaches its highest value during the peak hours. Hence, various rates can be considered for different hours of the day or different days of the week/year. The variable time-based rates are highlighted by defining elasticity. Elasticity is defined as the demand's sensitivity to price changes.

## 2.1 ELASTICITY

DRPs have been designed in a way to make the customer's demand more sensitive to the market price changes. The sensitivity of customer's demand to price is defined by (1) [30].

$$E = \frac{\partial q}{\partial \rho} = \frac{\rho_0}{q_0} \cdot \frac{dq}{d\rho} \quad (1)$$

The demands show two possible reactions to variable energy price at different time intervals [30]:

A) Single-period sensitivity: The loads that cannot be transferred to other periods and can only be turned on or off (such as lighting loads). The reaction of this type of loads to the price is called single-period sensitivity. These types of loads have self-elasticity.

B) Multi-period sensitivity: The loads that can be transferred to other periods. The electricity usage can be transferred from peak hours to mid-load or low-load hours (such as air conditioning and vacuum cleaner). The reaction of this type of loads to the price is called multi-period sensitivity. These types of load have cross-elasticity.

The small consumers hardly respond to changes in prices due to the specific characteristics of the electric energy and as a result, they fall into the first category. On the other hand, industrial consumers are inclined to reduce their load during peak hours and increase electricity usage during low-load and

mid-load periods to reduce their costs. They fall into the second category. According to the above definition, cross-elasticity of the  $z^{\text{th}}$  period to the  $z'^{\text{th}}$  period is defined by (2). Cross-elasticity is always positive while the self-elasticity is always negative. Single-period and multi-period models are individually discussed in the following sections.

$$E_{zz'} = \frac{\partial q_z}{\partial \rho_{z'}} = \frac{\rho_{0z'}}{q_{0z}} \cdot \frac{dq_z}{d\rho_{z'}} \quad (2)$$

## 2.2 SINGLE PERIOD MODEL

The loads which are unable to be shifted to other periods act with single-period sensitivity and have self-elasticity. To model these loads easier, it is initially assumed that only one customer exists. The obtained equations are then extended to a larger number of customers. The day is divided into multiple time periods based on demand. If the power demand in  $z^{\text{th}}$  period is represented by  $d_z$  and the energy price changes from  $r$  to  $r_z$ , then the customer's benefit after applying DRP and change in consumed power is obtained by (3) [31].

$$B_z = \rho_{0z} \Delta d_z \left( 1 + \frac{\Delta d_z}{2E_{zz}d_z} \right) \quad (3)$$

By assuming a fixed energy price, the customer's profit from consuming energy is calculated by (4).

$$S_z = B_z - \rho(d_z + \Delta d_z) = \rho \Delta d_z \left( 1 + \frac{\Delta d_z}{2E_{zz}d_z} \right) - \rho_z(d_z + \Delta d_z) \quad (4)$$

To maximize the customer's profit, the derivative of profit function is set to zero and it is solved for  $\Delta d_z$ .

$$\frac{\partial S_z}{\partial \Delta d_z} = \rho_{0z} + \rho_{0z} \frac{\Delta d_z}{E_{zz}d_z} - \rho_z = 0 \quad (5)$$

Then:

$$\Delta d_z = E_{zz}d_z \frac{(\rho_z - \rho_{0z})}{\rho_{0z}} \quad (6)$$

Thus, if the customers change their load based on (6), the maximum profit will be earned. Since  $\Delta d_z$  is a negative value due to negative self-elasticity term,  $\Delta d_z^-$  is defined by (7).

$$\Delta d_z^- = E_{zz}d_z \frac{(\rho_z - \rho_{0z})}{\rho_{0z}} \quad (7)$$

## 2.3 MULTI-PERIOD MODEL

The transferrable loads instead, react with multi-period sensitivity and show cross-elasticity. In the

multi-period model, the cross-elasticity is taken into account and the possibility of transferring loads from one period to another one is modeled. The changes in the other periods' demand due to load reduction in one period and shifting it to other periods which is shown by  $\Delta d_z^+$ , is calculated by (8)-(10). Equation (10) shows the relation between the load transferred to the period  $z$  and the load reduction in other periods.

$$\Delta d_z^+ = \sum_{z'=1, z' \neq z}^{NZ} E_{zz'} d_z \frac{(\rho_{z'} - \rho_{0z'})}{\rho_{0z'}} \quad (8)$$

$$\frac{(\rho_{z'} - \rho_{0z'})}{\rho_{0z'}} = \frac{\Delta d_z^-}{E_{z'z'} d_{z'}} \quad (9)$$

As a result:

$$\Delta d_z^+ = \sum_{z'=1, z' \neq z}^{NZ} \frac{E_{zz'} d_z}{E_{z'z'} d_{z'}} \Delta d_z^- \quad (10)$$

#### 2.4 FINAL MODEL

In the final model, the formulation is extended to consider several customers at every hour under different scenarios. By simplification and performing mathematical operations, the following equation for modeling TOU-DRP is obtained.

$$DR_{i,t,s}^- = P_{i,t,s}^D |E_{zz}| \frac{(\rho_t - \rho_{0t})}{\rho_{0t}} \quad \forall z \in Z_t \quad (11)$$

The load transferred to other periods according to cross-elasticity is calculated by the (12) [23]:

$$DR_{i,t,s}^+ = \frac{P_{i,t,s}^D}{D_{i,z,s}} \sum_{\substack{z'=1 \\ z' \neq z}}^{NZ} \sum_{t \in T_{z'}} \frac{E_{zz'}}{|E_{z'z'}|} \frac{D_{i,z,s}}{D_{i,z',s}} DR_{i,t',s}^- \quad \forall z \in Z_t \quad (12)$$

$$D_{i,z,s} = \sum_{t \in T_z} P_{i,t,s}^D \quad (13)$$

Therefore, the new load of bus  $i$  at time  $t$  and scenario  $s$  after running TOU-DRP, which is represented by  $P_{i,t,s}^{D,Mod}$ , is as follows:

$$P_{i,t,s}^{D,Mod} = P_{i,t,s}^D + DR_{i,t,s}^+ - DR_{i,t,s}^- \quad (14)$$

### 3 MODELING DEMAND RESPONSE PROGRAMS IN MG OPERATION

The objective of running DRP is to minimize the MG operation cost which is given by (15). In this

objective function, the first term shows the total operation cost of MTs, the second term represents the charging/discharging cost of the battery, and the third term denotes the costs of demands not supplied. Equation (15) minimizes the MG operation cost considering (16)-(31) constraints [32].

$$\begin{aligned}
Cost = \sum_{s=1}^{Ns} \pi_s \times \{ & \sum_{t=1}^{Nt} \sum_{MT=1}^{Nmt} (a_{mt} u_{mt,t,s} + b_{mt} P_{mt,t,s}^{MT}) \\
& + \sum_{t=1}^{Nt} \sum_{Bat_i=1}^{Nbat} (P_{b,t,s}^{dc} + P_{b,t,s}^{ch}) Cbat + \sum_{t=1}^{Nt} \sum_{i=1}^{Ni} VOLL_{i,t} LS_{i,t,s} \}
\end{aligned} \quad (15)$$

Power balancing constraints are expressed by (16). To maintain MG frequency in the permissible limits, generated power and consumed power at every moment must be equal. Buses, batteries, solar units, wind units, and microturbines which are connected to bus  $i$ , are illustrated by  $Bus_i$ ,  $Bat_i$ ,  $PV_i$ ,  $W_i$ , and  $MT_i$ , respectively.

$$\begin{aligned}
\sum_{mt \in MT_i} P_{mt,t,s}^{MT} + \sum_{w \in W_i} (P_{w,t,s}^W - S_{w,t,s}^W) + \sum_{pv \in PV_i} P_{pv,t,s}^{PV} + \sum_{b \in Bat_i} P_{b,t,s}^B \\
= \sum_{j \in Bus_i} PL_{i,j,t,s} + (P_{i,t,s}^D + DR_{i,t,s}^+ - DR_{i,t,s}^- - LS_{i,t,s})
\end{aligned} \quad (16)$$

Each generation unit in the MG has specific operation limits. In MTs, minimum and maximum powers are restrained while in wind and PV units, the maximum base predicted power generation based on wind speed and solar radiation, should not be surpassed. Equations (17)-(20) depict the power generation constraints of DERs (wind, PV, and MT).

$$P_{mt}^{MT,min} \cdot u_{mt,t,s} \leq P_{mt,t,s}^{MT} \leq P_{mt}^{MT,max} \cdot u_{mt,t,s} \quad (17)$$

$$P_{w,t,s}^W \leq P_{w,t,s}^{W,forecast} \quad (18)$$

$$P_{pv,t,s}^{PV} \leq P_{pv,t,s}^{PV,forecast} \quad (19)$$

$$0 \leq S_{w,t,s}^W \leq P_{w,t,s}^W \quad \forall W, \forall t, \forall s \quad (20)$$

Battery constraints are formulated in (21)-(26). A one-hour time interval considered in (25).

$$P_{b,t,s}^B = P_{b,t,s}^{dc} - P_{b,t,s}^{ch} \quad (21)$$

$$P_b^{ch,min} \cdot u_{b,t,s}^{ch} \leq P_{b,t,s}^{ch} \leq P_b^{ch,max} \cdot u_{b,t,s}^{ch} \quad (22)$$

$$P_b^{dc,min} \cdot u_{b,t,s}^{dc} \leq P_{b,t,s}^{dc} \leq P_b^{dc,max} \cdot u_{b,t,s}^{dc} \quad (23)$$

$$u_{b,t,s}^{ch} + u_{b,t,s}^{dc} \leq 1 \quad (24)$$

$$E_{b,t,s}^B = E_{b,(t-1),s}^B + \eta_b^{ch} \cdot P_{b,t,s}^{ch} - \frac{1}{\eta_b^{dc}} \cdot P_{b,t,s}^{dc} \quad (25)$$

$$E_b^{B,min} \leq E_{b,t,s}^B \leq E_b^{B,max} \quad (26)$$

AC load flow is used in this article. The power transfer capability of each line is limited and depends on the voltage, bus angle, and the line impedance. The load flow-related constraints are represented by (27)-(31).

$$PL_{i,j,t,s} = G_{i,j} |V_{i,t,s}|^2 - |V_{i,t,s}| |V_{j,t,s}| \{G_{i,j} \cos(\delta_{i,t,s} - \delta_{j,t,s}) + B_{i,j} \sin(\delta_{i,t,s} - \delta_{j,t,s})\} \quad (27)$$

$$QL_{i,j,t,s} = -B_{i,j} |V_{i,t,s}|^2 - |V_{i,t,s}| |V_{j,t,s}| \{G_{i,j} \sin(\delta_{i,t,s} - \delta_{j,t,s}) - B_{i,j} \cos(\delta_{i,t,s} - \delta_{j,t,s})\} \quad (28)$$

$$-SL_{i,j}^{max} \leq \sqrt{PL_{i,j,t,s}^2 + QL_{i,j,t,s}^2} \leq SL_{i,j}^{max} \quad (29)$$

$$V_i^{min} \leq V_{i,t,s} \leq V_i^{max} \quad (30)$$

$$\begin{cases} V_{i,t,s} = 1 \\ \delta_{i,t,s} = 0 \end{cases} \quad \forall i = slack \quad (31)$$

#### 4 NUMERICAL ANALYSIS AND SIMULATION.

Fig. 1 illustrates the procedure of the simulation which includes initialization, scenario generation, scenario reduction, demand prediction, TOU-DRP-based load flow, and MG scheduling. Evaluation of the proposed methodology is conducted based on the simulation results. The models presented in the previous sections are implemented on an isolated case study MG which includes wind and energy storage unit (battery). In this MG, all the required power of the loads is supplied by the generation units located within the MG. The impact of running TOU-DRP and different installed wind power capacities with/without battery on MG operation is analyzed extensively. The impact of customers' participation levels on operation cost, unserved energy, and wind power spillage are also investigated.

In order to validate the presented models, an 11-bus isolated MG with uncertainties is simulated in a 24-hour period and the results of various cases are presented. The selected MG contains two microturbines (MTs), a wind unit, a solar unit (PV), and a battery, as shown in Fig. 2. [33].

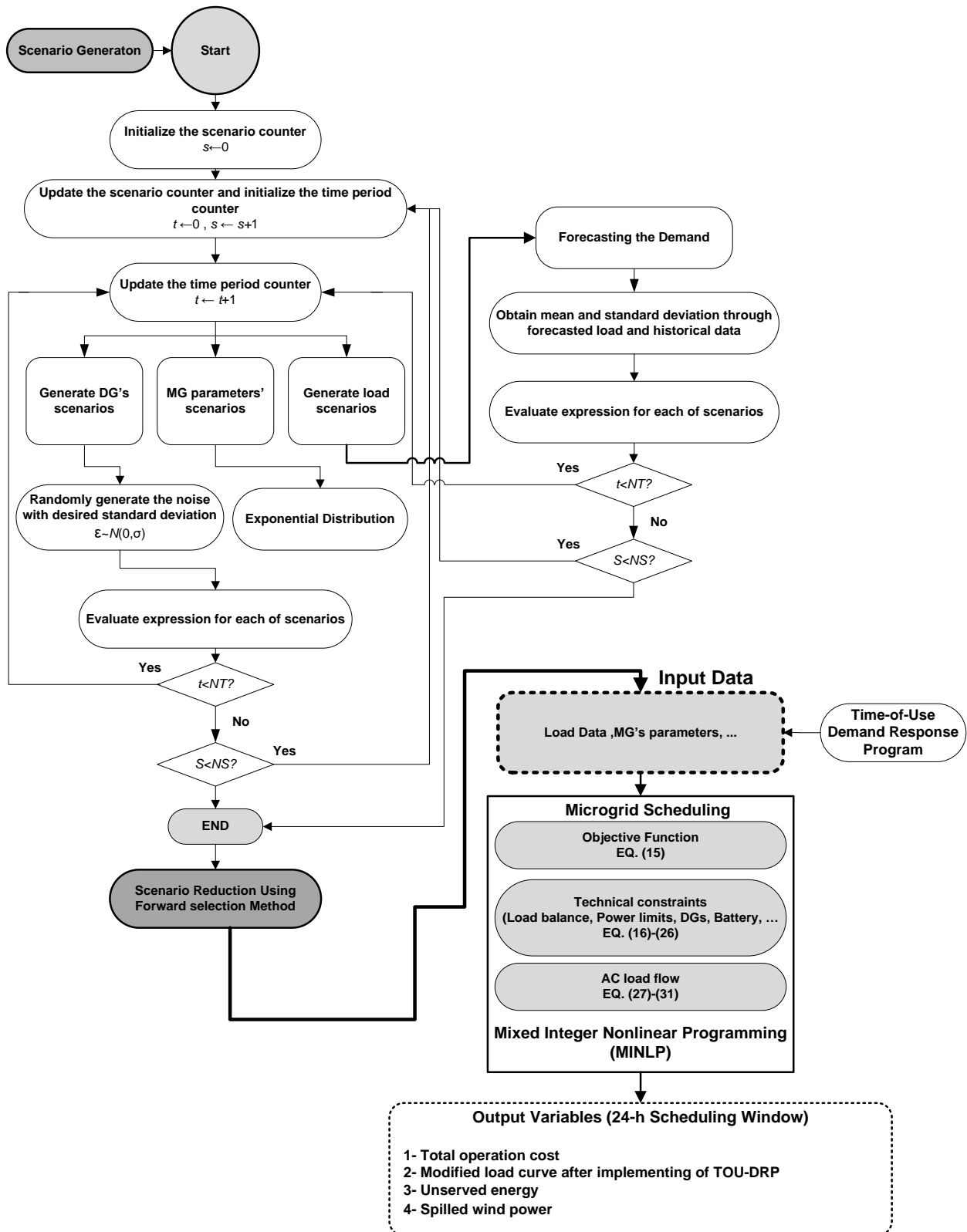

Fig 1: Flowchart of the simulation procedures

To cover the stochastic nature of wind power in MG operation, a battery with a maximum operation capacity of 30 kWh, and the minimum charge/discharge rate of 15 kW is considered. This battery with an initial charge of 20 kWh, charge/discharge efficiency of 85%, and charge/discharge cost of 20 cents/kWh is located at bus 8 [33,34]. The wind unit with the mathematical model of [35] and base

capacity of 15 kW is situated on bus 6. To model the uncertainty of wind power generation, a 10% error is considered. A PV unit with a capacity of 25 kW is installed at bus 3. The PV and wind unit output data are calculated by using the expert forecasting model presented in [34,36]. Detailed information on installed DG units is listed in Table 1 [34].

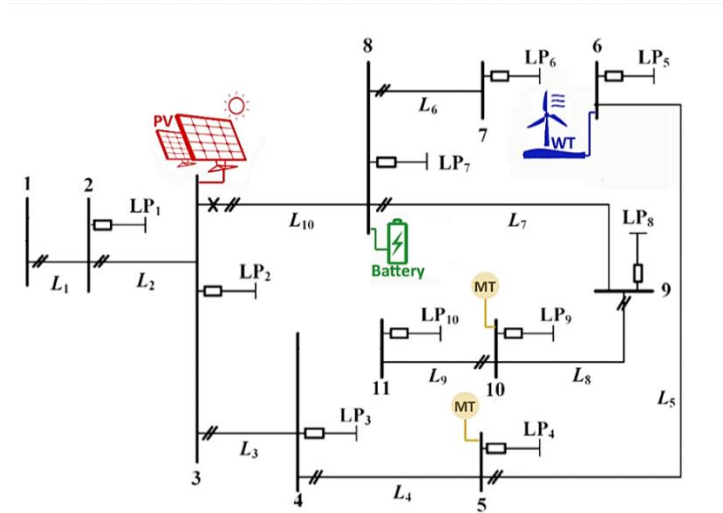

Fig 2: 11 bus MG

Table 1: Installed DG Units

Type	Min power (kW)	Max power (kW)
Wind Unit	0	15
PV Unit	0	25
Battery	-15	15
Microturbine1	6	30
Microturbine2	3	30

Scenario generation algorithms are utilized to model uncertainties. The past data of the system are deployed in scenario generation algorithm to produce possible decision variables for problem-solving. Sampling is a common method to generate scenarios where multiple scenarios are created by sampling the data distribution function. Monte Carlo simulation which is a sampling method for scenario generation is used in this paper. In Monte Carlo simulation, each scenario proposes a new decision [37,38]. The scenarios with low probability are then removed or merged with those which are close to them in a process called scenario reduction. Scenario reduction helps to decrease the cost and time of investigating all possible states. Two major scenario reduction methods are Backward Reduction and Forward Reduction.

Forward Reduction based method is employed in this research [39,40]. 1000 scenarios are initially generated and then they are decreased to 8 scenarios with 8 corresponding probabilities. The pseudo-code representation of the scenario generation algorithm to model the uncertainties is illustrated in Algorithm 1.

*Algorithm 1. scenario generation algorithm*

---

1	Start	
	Initialization:	
2	Initialize $d_t^0$	$d_t^0$ : hourly forecasted value.
3	Consider $t = 1$	$t$ : hour index.
4	Consider $s = 1$	$s$ : scenario index
5	Generate a random number $\psi_t^s$ based on a normal distribution function (with the mean value of $d_t^0$ and standard deviation of $\sigma$ )	$\sigma$ : forecasting error or standard deviation of the normal distribution function
6	Calculate $d_t^s = d_t^0 + \psi_t^s * \sigma$	
7	if all the required scenarios are generated	
8	go to line 12	
9	else	
10	$s = s + 1$	
11	go to line 5	
12	if all the required hours are generated	
13	go to line 17	
14	else	
15	$t = t + 1$	
16	go to line 5	
17	Save all the generated scenarios	
18	End	

---

The per-unit base power generation of wind unit and PV with respect to their rated capacities are shown in Fig 3 demonstrates the percentage-based hourly load curve with a peak value of 90 kW and load curve [33, 34]. The load curve is divided into three intervals as following: low load period (1:00 to 7:00), mid-load period (7:00 to 9:00 & 16:00 to 20:00) and peak period (9:00 to 16:00). Load distribution in different buses is denoted in Table 2 [19]. Load ratio is calculated by dividing each bus's load by the total load of the MG. After bus 1, bus 7 has the lowest load ratio compared to other buses of the MG [41].

*Table 2: Load distribution in different buses*

Bus	1	2	3	4	5	6	7	8	9	10	11
Load (%)	0	17.79	8.89	7.68	12.9	9.78	1.37	10.46	10.21	15.03	5.89

The average prices of selling energy and the Value of Lost Load (VOLL) corresponding to the MG case study are 15 cents/kWh and 400 cents/kWh, respectively

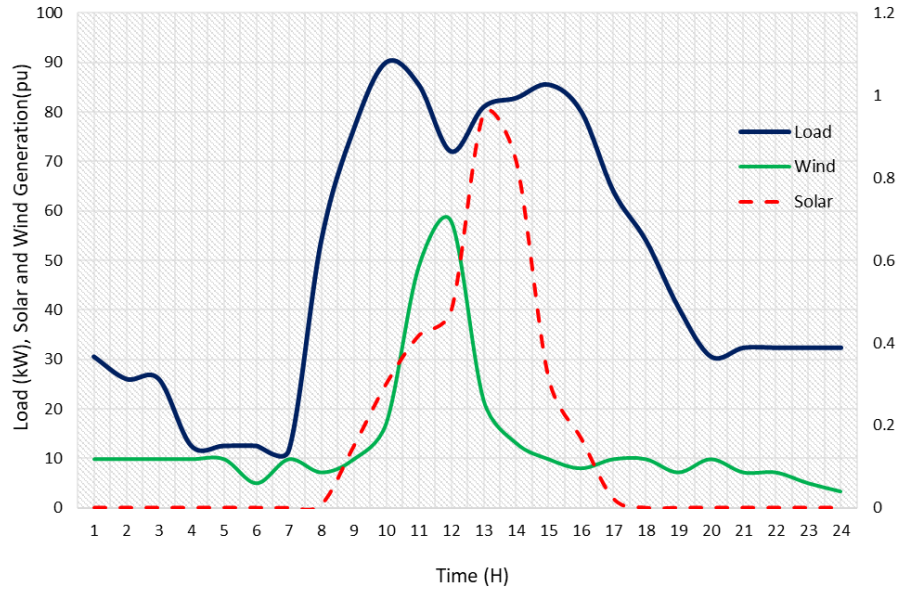

Fig 3: Base power generation of wind and PV units and Predicted hourly load curve of the 11-bus MG [16,19]

. Table 3 shows the three price rates used in the TOU-DRP. The self-elasticity and cross-elasticity of customers are extracted from [36].

Table 3: Pricing of the three rates in TOU-DRP

	Low load	Middle load	Peak
Price (cent/kWh)	5	20	40

Now, by considering periods, prices, elasticity factors, and potentials, different cases for running this program are designed. The simulation results are provided in 12 cases which are all possible combinations of three different wind capacity and four different participation levels of customers. Different capacities of installed wind power and customer’s participation levels in TOU-DRP are listed in Table 4 and Table 5, respectively.

Table 4 :Different capacities of installed wind power

	WP1	WP1	WP1
The capacity of the installed wind unit (kW)	15	30	45

Where

WP1 The base capacity of the installed wind unit (15kW)

WP2 Twice the nominal capacity of the installed wind unit (30kW)

WP3 Three times the nominal capacity of the installed wind unit (45kW)

Table 5: Different percentages of customers' participation level

	CP1	CP2	CP3	CP4
Customers' participation (%)	0	20	40	60

Each of these conditions is simulated with and without using the battery. Considering the fact that objective function optimization and implementing various constraints on the MG are nonlinear and quite complex problems, Mixed-Integer Non-Linear Programming (MINLP) technique is used for simulation and optimization of the cost function. GAMS optimization software is used to perform the calculations. SENERD option is used in GAMS to reduce the number of scenarios through Forward Reduction method [39].

When the customers' participation level is zero, the operator solves an optimization problem to minimize the MG operation costs without considering TOU-DRP. Then, the TOU-DRP is implemented based on the model presented earlier and the different capacities of installed wind power, with/without the battery are analyzed. In fact, the battery is used to cover the uncertainties of wind power. The extra power is stored during off-peak hours and delivered to the network during peak hours.

#### 4.1.1 SIMULATION RESULTS

First, the TOU-DRP is implemented in MG base case operation including battery, 15 kW of installed wind capacity, and 20% customers' participation level. Fig 4 shows the impact of running TOU-DRP on the MG load curve. As shown in this figure, by implementing the TOU-DRP, 26.06 kWh of peak loads are reduced and 11.65 kWh of the loads are shifted to other time periods (mid-load and low load period).

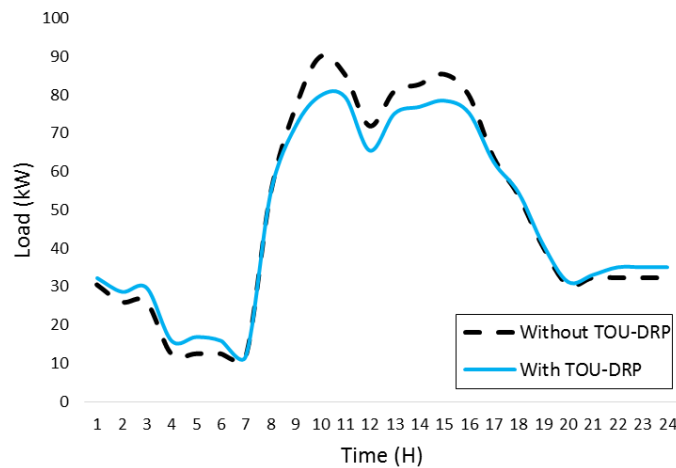
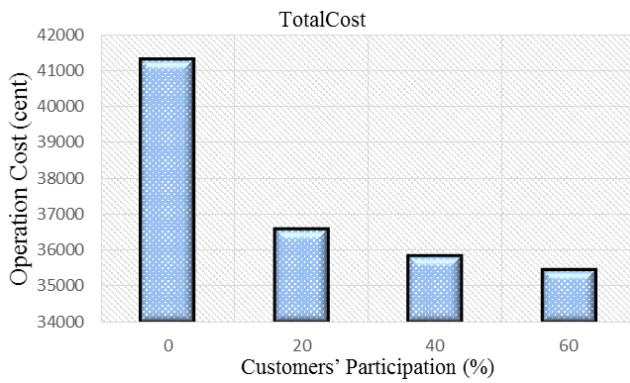

Fig 4: Shaved load curve after implementing TOU-DRP, with considering battery, 15 kW of installed wind capacity and 20% customers' participation level

Without running TOU-DRP, 0% participation of customers, the total operation cost of MG is 41294 cents. After running TOU-DRP with wind capacity of 15 kW, considering battery, and 20% participation of customers, the total operation cost decreases to 36591 cents/kWh. By comparing these two conditions, it can be noted that the total operation cost is reduced by 4703 cents. Fig 5 - Fig 8 depict the impact of running TOU-DRP and different customers' participation level on MG operational factors in the base case operation.

The total operation cost of the MG, which is represented in Fig 5, is substantially decreased by customers' participation in TOU-DRP. This reduction is due to the lower load peak as a result of shifting the load to off-peak hours by participating customers. The total operation cost reduction continues with gradually increasing the customers' participation level with a smoother slope.

Fig 6 illustrates the higher load factor due to running TOU-DRP in the MG. The load factor is the ratios of the actual energy consumption (kWh) to the maximum demand for that period of time. By increasing the customers' participation level more loads are shifted from peak hours to off-peak hours and the maximum demand reduces. Hence, a higher participation level leads to a higher load factor.



*Fig 5: Total operation cost of MG in the base case with different customers' participation in TOU-DRP*

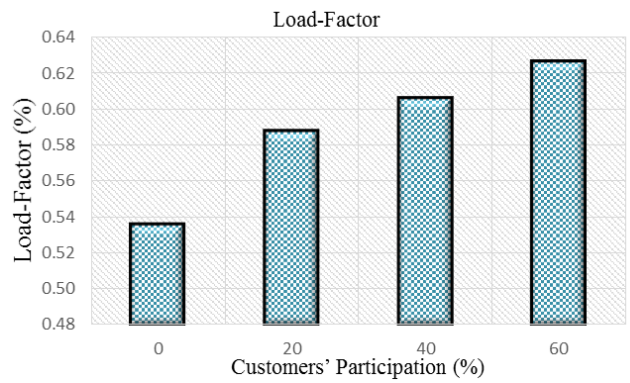

*Fig 6: Load Factor of MG in the base case with different customers' participation in TOU-DRP*

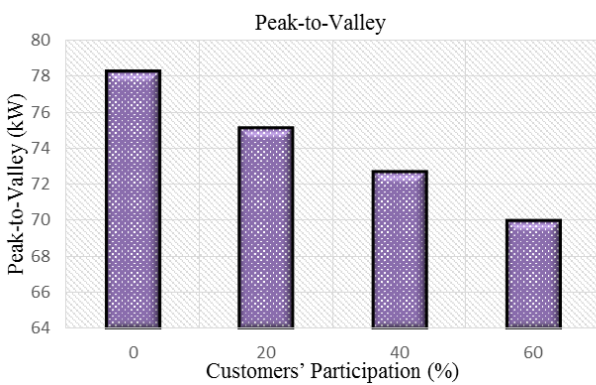

*Fig 7: The amount of peak-to-valley of load curve in the base case with different customers' participation*

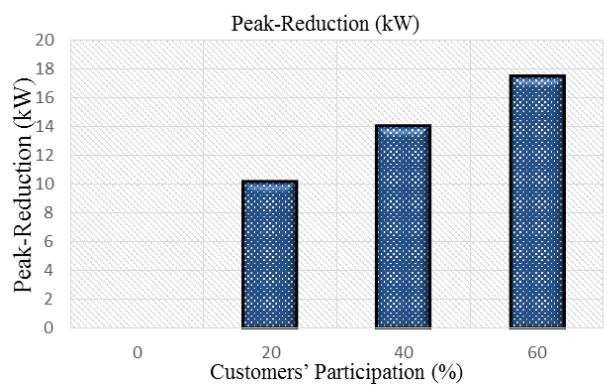

*Fig 8: The amount of peak reduction in the base case with different customers' participation in TOU-DRP*

Peak-to-valley of the load curve and peak reduction, which are two important factors in MG operation, are represented in Fig 7 and Fig 8, respectively. Peak-to-Valley decreases and peak reduction increases which gradually increasing the customers' participation level, confirming improved MG operation by running TOU-DRP. TOU-DRPs' role in decreasing and shifting the peak load has already been discussed in detail.

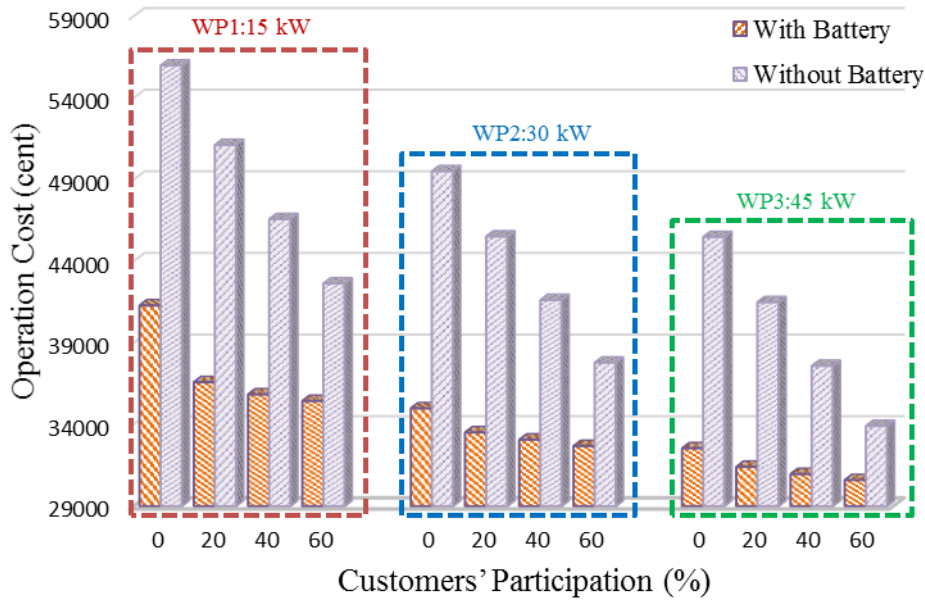

Fig 9: Total operation cost with/without considering Battery

The total operation costs of the MG with/without the battery is presented in Fig 9. Using battery in MG leads to lower operation cost because of the battery's capability in saving the energy in off-peak hours and injecting it to the MG during peak hours. As also depicted in Fig 5 and Fig 6, increasing the customers' participation and the capacity of installed wind power will further decrease the operation cost. The cross-elasticity feature of the loads is also effective in shifting them to the off-peak hours and decrease the peak demand which consequently reduces the operation cost.

The unserved energy with/without battery versus different customers' participation levels and various installed wind power capacities is indicated in Fig 10. It is obvious that unserved energy increases when the battery is not considered. The battery can save the cheaper energy in off-peak hours and release it during peak hours that is the most appropriate time of load shedding. In addition, the major contribution of the TOU-DRP is to mitigate the peak demand and shift the loads to off-peak hours which helps reduce the unserved energy in peak hours. By increasing the installed wind power capacities and consequently injecting more power into the MG by wind units, the unserved energy reduces.

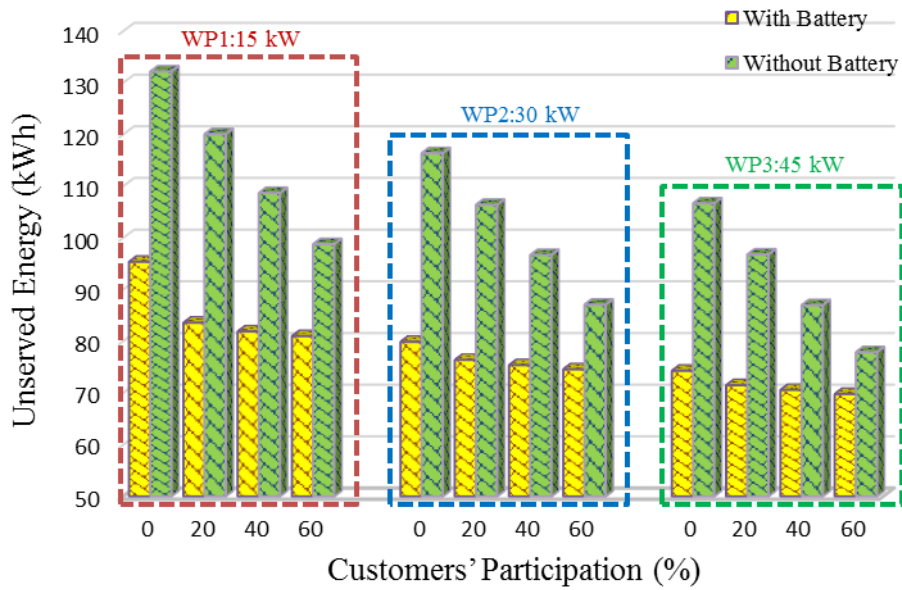

Fig 10: Unserved energy with considering battery

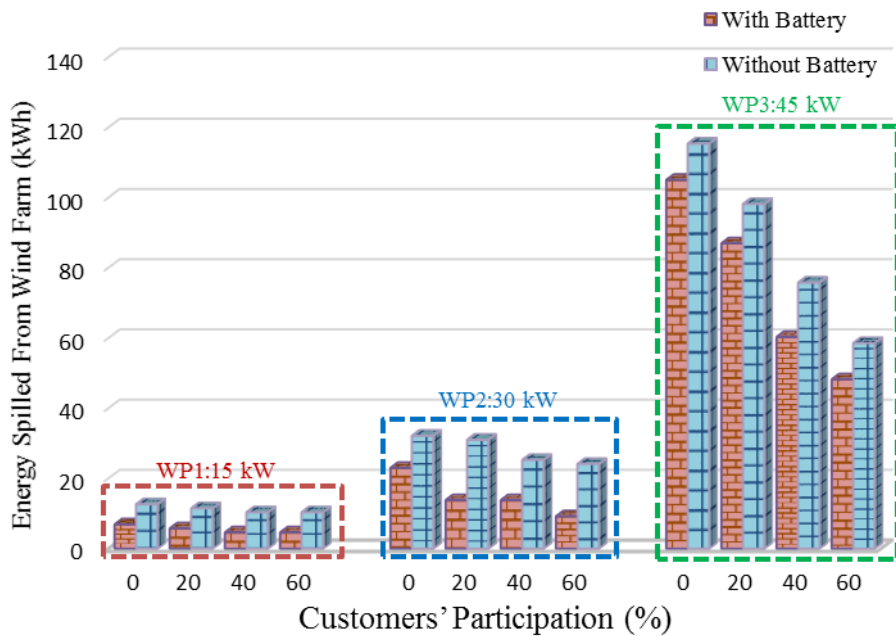

Fig 11: Spilled wind power with considering battery

Fig 11 demonstrates that running TOU-DRP and increasing the customers' participation level significantly decrease the wind power spillage. The effect of customers' participation level on wind power spillage is more noticeable in the higher capacities of installed wind power. This figure also confirms the impact of battery in decreasing the wind power spillage. By comparing the two graphs, it can be observed that the battery decreases the wind power spillage to about 50% in low wind power (15kW). The impact of battery in wind power spillage decreases when the capacity of wind power increases. Because the battery capacity is constant while the installed wind power capacity is increasing. The battery's role in

reducing wind power spillage is similar to a reserved power source. The extra produced wind power due to the wind forecast error is saved in the battery instead of being spilled. When the wind generation is not remarkable, and the MG needs more power, the battery acts as a reserved source to help the power balance.

*Table 6: MINLP solution time in different cases*

Wind capacity (kW)	Customers' Participation (%)	With battery (1) Without Battery (0)	Time (s)
15	0	1	242
		0	218
	20	1	872
		0	829
	40	1	983
		0	982
60	1	996	
	0	936	
30	0	1	239
		0	230
	20	1	883
		0	885
	40	1	989
		0	927
60	1	1011	
	0	1003	
45	0	1	247
		0	243
	20	1	870
		0	849
	40	1	997
		0	959
60	1	1016	
	0	1001	

These cases are modeled as MINLP problems and solved by GAMS optimization software on a 1.73GHz Intel(R) Core(TM) i7-Q740 CPU with 4GB RAM system. Given that MINLP is very hard to solve, the elapsed time for solving MINLP problem in different cases are proposed in Table 6. As shown in the table, the solution time is increased after implementing DR program. Moreover, with increasing the customer's participation level in different scenarios, the elapsed time for solving the MINLP model is increased.

## 5 CONCLUSION

In this paper, the effects of running TOU-DRP based on price elasticity and customer benefit in an isolated MG with different wind unit penetration with/without using the battery is analyzed. To evaluate

the performance of the proposed model, it is implemented on an 11-bus MG over a 24-hour period for twelve detailed cases. First, the impact of implementing TOU-DRP and increasing customers' participation level on different MG operational factors are investigated. Decreasing the total operation cost and the amount of peak-to-valley while increasing the load factor and the amount of peak reduction were the main achievements of the proposed model. Then, it is observed that when a wind generation unit with high capacity participates in MG operation, the presence of the battery prevents the wind power spillage. In fact, when the MG requires a large amount of power to supply the demands and the wind unit cannot produce enough power due to uncertainty, the battery acts as a reserved source to help power balancing of the MG. In addition, the results provided that running TOU-DRP, increasing the customers' participation, and increasing the capacity of installed wind power, all contribute to reducing the operation cost. Running the TOU-DRP also leads to mitigate the peak load as well as total load demand which leads to unserved energy reduction. By appropriate and effective use of the battery, the extra power produced through generation units of the MG during off-peak hours can be stored and then used to supply the loads during the peak hours.

## References

- [1] N. W. A. Lidula and A. D. Rajapakse, "Microgrids research: A review of experimental microgrids and test systems," *Renewable and Sustainable Energy Reviews*, vol. 15, pp. 186-202, 2011
- [2] Ferruzzi, Gabriella, et al. "Optimal bidding in a Day-Ahead energy market for Micro Grid under uncertainty in renewable energy production." *Energy* 106 (2016): 194-202.
- [3] Oliveira, D. Q., et al. "A fuzzy-based approach for microgrids islanded operation." *Electric Power Systems Research* 149 (2017): 178-189.
- [4] A. G. Tsikalakis and N. D. Hatziargyriou, "Centralized Control for Optimizing Microgrids Operation," *Energy Conversion, IEEE Transactions on*, vol. 23, pp. 241-248, 2008
- [5] D. Lu and B. Francois, "Strategic framework of an energy management of a microgrid with a photovoltaic-based active generator," *International Symposium Advanced. ELECTROMOTION*, pp. 1-6, 2009
- [6] Huang, Chongxin, et al. "Distributed cooperative control of energy storage units in microgrid based on multi-agent consensus method." *Electric Power Systems Research* 147 (2017): 213-223.
- [7] Hosseini Imani, Mahmood, et al. "Impact Evaluation of Electric Vehicle Parking on Solving Security-Constrained Unit Commitment Problem." *Mathematical and Computational Applications* 23.1 (2018): 13..

- [8] Mazidi, Mohammadreza, et al. "Integrated scheduling of renewable generation and demand response programs in a microgrid." *Energy Conversion and Management* 86 (2014): 1118-1127.
- [9] US Department of Energy, February 2006 "Benefits of Demand Response in Electricity Markets and Recommendations for Achieving them, Report to the United States Congress," available online: <http://eetd.lbl.gov>
- [10] Aalami, H. A., M. Parsa Moghaddam, and G. R. Yousefi. "Evaluation of nonlinear models for time-based rates demand response programs." *International Journal of Electrical Power & Energy Systems* 65 (2015): 282-290.
- [11] Rahmani-andebili, Mehdi. "Modeling nonlinear incentive-based and price-based demand response programs and implementing on real power markets." *Electric Power Systems Research* 132 (2016): 115-124.
- [12] Dehnavi, Ehsan, and Hamdi Abdi. "Optimal pricing in time of use demand response by integrating with dynamic economic dispatch problem." *Energy* 109 (2016): 1086-1094.
- [13] Imani, Mahmood Hosseini, et al. "Strategic Behavior of Retailers for Risk Reduction and Profit Increment via Distributed Generators and Demand Response Programs." *Energies* 11.6 (2018): 1-24.
- [14] Aalami, H., G. R. Yousefi, and M. Parsa Moghadam. "Demand response model considering EDRP and TOU programs." *Transmission and Distribution Conference and Exposition, 2008. T&D. IEEE/PES. IEEE, 2008.*
- [15] Asadinejad, Ailin, and Kevin Tomsovic. "Optimal use of incentive and price based demand response to reduce costs and price volatility." *Electric Power Systems Research* 144 (2017): 215-223.
- [16] Imani, Mahmood Hosseini, et al. "Demand Response Modeling in Microgrid Operation: a Review and Application for Incentive-Based and Time-Based Programs." *Renewable and Sustainable Energy Reviews* 94 (2018): 486-499.
- [17] Imani, Mahmood Hosseini, et al. "Effect of Changes in Incentives and Penalties on Interruptible/Curtailable Demand Response Program in Microgrid Operation." *2019 IEEE Texas Power and Energy Conference (TPEC). IEEE, 2019.*
- [18] F. Katiraei, R. Iravani, N. Hatziargyriou, and A. Dimeas, "Microgrids management," *IEEE Power and Energy Magazine*, vol. 6, no. 3, pp. 54–65, 2008.
- [19] Imani, Mahmood Hosseini, et al. "Running direct load control demand response program in microgrid by considering optimal position of storage unit." *Texas Power and Energy Conference (TPEC), 2018 IEEE. IEEE, 2018.*
- [20] Di Somma, Marialaura, Giorgio Graditi, and Pierluigi Siano. "Optimal Bidding Strategy for a DER aggregator in the Day-Ahead Market in the presence of demand flexibility." *IEEE Transactions on Industrial Electronics* 66.2 (2019): 1509-1519.
- [21] Zhang, Cuo, et al. "Robust Coordination of Distributed Generation and Price-Based Demand Response in Microgrids." *IEEE Transactions on Smart Grid* (2017).
- [22] Aghajani, G. R., H. A. Shayanfar, and H. Shayeghi. "Demand side management in a smart micro-grid in the presence of renewable generation and demand response." *Energy* 126 (2017): 622-637.

- [23] Imani, M. Hosseini, Payam Niknejad, and M. R. Barzegaran. "The impact of customers' participation level and various incentive values on implementing emergency demand response program in microgrid operation." *International Journal of Electrical Power & Energy Systems* 96 (2018): 114-125.
- [24] H. Kumar Nunna and S. Doolla, "Energy management in microgrids using demand response and distributed storage a multiagent approach," *IEEE Transactions on Power Delivery*, vol. 28, no. 2, 2013.
- [25] Kerdphol, Thongchart, Yaser Qudaih, and Yasunori Mitani. "Optimum battery energy storage system using PSO considering dynamic demand response for microgrids." *International Journal of Electrical Power & Energy Systems* 83 (2016): 58-66.
- [26] Mahmoudi, Nadali, et al. "A bottom-up approach for demand response aggregators' participation in electricity markets." *Electric Power Systems Research* 143 (2017): 121-129.
- [27] A. Zakariazadeh, S. Jadid and P. Siano, "Smart Microgrid energy and reserve scheduling with Demand Response stochastic Optimization", *Int J Electr Power Energy Syst* vol. 63, pp. 523-533, 2014.
- [28] Geramifar, Hasan, Majid Shahabi, and Taghi Barforoshi. "Coordination of Energy Storage Systems and Demand Response Resources for Optimal Scheduling of Microgrids under Uncertainties." *IET Renewable Power Generation* (2016).
- [29] M. H. Albadi and E. El-Saadany, "Demand response in electricity markets: An overview," in *IEEE power engineering society general meeting*, 2007, pp. 1-5.
- [30] Kirschen DS, Strbac G. *Fundamentals of power system economics*. John Wiley & Sons; 2004.
- [31] H. Aalami, et al., "Optimum time of use program proposal for Iranian power systems," in *Electric Power and Energy Conversion Systems*, 2009. EPECS'09. International Conference on, 2009, pp. 1-6.
- [32] Shahidepour, M. (2012). "Operation and Control Microgrid and Distributed Generation." *Illinois Institute of Technology*.
- [33] X. Xu, et al., "Evaluation of Operational Reliability of a Microgrid Using a Short-Term Outage Model," *Power Systems*, *IEEE Transactions on*, vol. 29, pp. 2238-2247, 2014.
- [34] A. A. Moghaddam, et al., "Multi-operation management of a typical micro-grids using Particle Swarm Optimization: A comparative study," *Renewable and Sustainable Energy Reviews*, vol. 16, pp. 1268-1281, 2012.
- [35] R. Karki, et al., "A simplified wind power generation model for reliability evaluation," *Energy conversion*, *IEEE Transactions on*, vol. 21, pp. 533-540, 2006.
- [36] Chen, Changsong, et al. "Smart energy management system for optimal microgrid economic operation." *IET renewable power generation* 5.3 (2011): 258-267.
- [37] Shapiro, Alexander. "Monte Carlo simulation approach to stochastic programming." *Simulation Conference*, 2001. *Proceedings of the Winter*. Vol. 1. IEEE, 2001.
- [38] Zalzar, Shaghayegh, and Ettore Bompard. "A Day-Ahead Joint Energy and Uncertainty Reserve Market Clearing Model to Manage VRE Uncertainty." *2018 IEEE International Conference on Environment and Electrical Engineering and 2018 IEEE Industrial and Commercial Power Systems Europe (EEEIC/I&CPS Europe)*. IEEE, 2018.
- [39] [Online]. Available: <http://www.gams.com/>

- [40] L. Wu, M. Shahidehpour, and T. Li, "Stochastic security-constrained unit commitment," *Power Systems, IEEE Transactions on*, vol. 22, pp. 800-811, 2007.
- [41] H. Aalami, et al., "Modeling and prioritizing demand response programs in power markets," *Electric Power Systems Research*, vol. 80, pp. 426-435, 2010.