

New technologies for mobile mapping

Original

New technologies for mobile mapping / Bendea, H.; Boccardo, P.; Dequal, S.; Tonolo, F. G.; Marenchino, D.. - In: INTERNATIONAL ARCHIVES OF THE PHOTOGRAMMETRY, REMOTE SENSING AND SPATIAL INFORMATION SCIENCES. - ISSN 1682-1750. - 36:(2007), pp. 1-6. (Intervento presentato al convegno 5th International Symposium on Mobile Mapping Technology, MMT 2007 tenutosi a Padova, Palazzo Bo, Via VIII Febbraio no2, ita nel 2007).

Availability:

This version is available at: 11583/2915452 since: 2021-07-27T21:47:55Z

Publisher:

International Society for Photogrammetry and Remote Sensing

Published

DOI:

Terms of use:

This article is made available under terms and conditions as specified in the corresponding bibliographic description in the repository

Publisher copyright

(Article begins on next page)

NEW TECHNOLOGIES FOR MOBILE MAPPING

Horea Bendea^a, Piero Boccardo^b, Sergio Dequal^a, Fabio Giulio Tonolo^b, Davide Marenchino^a

^a DITAG, Land Environment and Geo-Engineering Department of the Politecnico di Torino, C.so Duca degli Abruzzi 24, 10129 Turin, Italy – (horea.bendea, sergio.dequal, davide.marenchino)@polito.it

^b ITHACA, Information Technology for Humanitarian Assistance Cooperation and Action, Via Pier Carlo Boggio 61, 10138 Turin, Italy – (piero.boccardo, fabio.giuliotonolo)@ithaca.polito.it

KEY WORDS: UAV, photogrammetry, payload, GPS/IMU, triangulation

ABSTRACT:

This paper deals with the development of a low cost UAV (Unmanned Aerial Vehicle) devoted to early impact phase in case of environmental disasters, based on geomatics techniques. “Pelican” is a low-cost UAV prototype equipped with a photogrammetric payload that will allow reconnaissance operations in remote areas and rapid mapping production. Different digital sensors installed in the payload allow to acquire high resolution frame images. Furthermore a GPS/INS unit will enable an automated navigation (except take-off and landing). The project is supported by ITHACA (Information Technology for Humanitarian Assistance, Cooperation and Action), an association founded by Politecnico di Torino and SiTI (Istituto Superiore sui Sistemi Territoriali per l’Innovazione) in cooperation with WFP (World Food Programme) and some private and public organisms, with the main goal to carry on operational and research activities in the field of geomatics for analysis, evaluation and mitigation of natural and manmade hazards. The main technical features of the UAV and the on-board payload are detailed described in the first part of the paper. Furthermore first results of stereopairs orientation, case studies and further developments are presented.

1. INTRODUCTION

Early impact activities related to environmental emergencies are mainly devoted to deliver georeferenced information and to produce thematic maps that can be useful to the people operating in the field. Satellite imagery are the main input data required to extract information such as flooded areas or damaged infrastructures. If satellite data are not available or not suitable to supply radiometric and geometric information, in situ missions must be foreseen. To this purpose the project ITHACA is developing a “low cost” mini-UAV. “Pelican” is a remote-controlled aircraft equipped with a GPS/IMU navigation system and different photographic sensors suitable for digital photogrammetric shootings with satisfying geometric and radiometric quality. It can be easily transportable on normal aircrafts and usable on the field by a couple of operators. Nowadays several test flights have been performed in order to evaluate the performances of the sensors and to test the implemented hardware. Results are detailed described in the last part of this paper.

2. UAV SYSTEMS

2.1 UAV definition and classification

UAV is the acronym of Unmanned Aerial Vehicle and refers to a class of aircrafts that can fly without the onboard presence of pilot. They can be flown by an electronic equipment present on the vehicle and at a GCS (Ground Control Station), or directly from the ground. In this last case it is common to associate the system with the expression RPV (Remotely Piloted Vehicle), since the vehicle is remotely piloted and operated by radio-controlled devices. In literature other terms are adopted to indicate such category of vehicles, such as: Drone, ROA (Remotely Operated Aircraft), UVS (Unmanned Vehicle System).

The development of UAVs started in the 50’s for military purposes. During the cold war, different countries started projects with the aim of producing vehicles able to carry out missions including reconnaissance, surveillance and penetration of hostile territories, with no onboard pilot. Particular attention was turned to the D3 (Dirty, Dull, Dangerous) missions in war areas.

At present the market for UAVs has been rapidly growing in the military ambit. The constant increase of research programmes and the evolving technologies have allowed to implement systems able to fully satisfy the requested requirements. In fact, during the recent conflicts in Bosnia, Iraq and Lebanon, UAVs were used for reconnaissance and patrolling operations.

The success in the military field offers a valid stimulus for the development of such systems for civil applications, especially in the field of environmental monitoring, agriculture and public security.

UAV Categories	Acronym	Range (km)	Climb rate (m)	Endurance (hours)	Mass (kg)
Tactic					
Micro	μ (Micro)	< 10	250	1	<5
Mini	Mini	< 10	150 to 300	< 2	150
Close Range	CR	10 a 30	3000	2 to 4	150
Short Range	SR	30 a 70	3000	3 to 6	200
Medium Range	MR	70 a 200	5000	6 to 10	1250
Medium Range Endurance	MRE	> 500	8000	10 to 18	1250
Low Altitude Deep Penetration	LADP	> 250	50 to 9000	0.5 to 1	350
Low Altitude Long Endurance	LALE	> 500	3000	>24	< 30
Medium Altitude Long Endurance	MALE	> 500	14000	24 to 48	1500

Table 1. UAV classification (UAV association)

The use of unmanned vehicles would ensure the possibility of carrying out long missions, without risking human losses and performing large-scale monitoring operations. UAV association classifies UAVs in three categories with respect to their possible usage. Each typology of aerial vehicle is subdivided into subcategories, according to their features and performance; particular reference is made to the vehicle's range, maximum climb rate, endurance and weight. Our attention is focused on the "tactical" group, in particular to the mini UAVs (see table 1).

2.2 UAV for civil applications

Nowadays the design and the use of UAVs in the military field is rapidly growing up. In the USA there are about 50 companies working in the field of UAVs and as many enterprises producing the relative equipment (communication systems, sensors, ...). In the last years few projects dealing with the use of UAVs for civil applications have been developed. The idea about a possible use of UAVs for monitoring operations rose few years ago. Therefore research centres and aerospace industries started the production of "low cost" systems.

"UAV Association" (2005) provided an evaluation of UAVs manufactured in the world: in comparison with the number of existent systems (603) the 8% is a exclusive civil use, while the 13% is a hybrid civil/military use.

These statistics demonstrate that there are great remarks for a development of civil UAV market. The growing interest for these systems is also due to the advantages they present in comparison to traditional aircrafts:

- their flight performance: UAVs can operate in a wide range of operational altitudes (from 100 to over 30,000 m) and have an elevated range of endurance (1-48 hours); the result is the possibility of carrying out small, medium and large scale monitoring operations;
- their adaptability to various typologies of missions: such systems can be utilized for monitoring missions in remote areas, also when highly hazardous to human life;
- their inexpensiveness: the possibility of designing aerial vehicles with variable dimensions, relatively reduced weight, and no onboard personnel allows to carry out flight operations at lower costs compared to the ones required by traditional aircrafts.

Nevertheless there are also some limits to overcome:

- the high costs of the assurances for civil missions and the difficulties to obtain them;
- the lack of sure communication frequencies that can give rise serious dangers during flight operations;
- the absence of laws that prescribe the UAV flights out of protected areas.

Recently UAV Task-Force working group, according to the International Aeronautic Authority has made a new classification for civil UAV concerning the future applications:

A - Technology induced applications

These applications are using "mini UAV" with miniaturized payload for monitoring and surveillance operations in limited areas;

B - Platform induced applications

Military UAV working at a middle altitude are performing government and scientific missions, besides monitoring operations in wide areas;

C - Service induced applications

Geostationary UAVs are establishing a new spatial network for telecommunication and earth observation.

At the moment civil UAVs allow to carry out the application of category A and B, in particular in the following sectors:

Land Monitoring and Remote Sensing:

- meteorology and atmospheric pollution control;
- hydro geological and geophysical control;
- monitoring of areas either affected by natural disasters or contaminated;
- surveying of archaeological areas.

Agriculture:

- spraying and treatment with chemical products;
- monitoring of agricultural resources and cultivation phases.

Public security:

- borders and (road/rail) traffic surveillance;
- support to recovery/rescue operations.

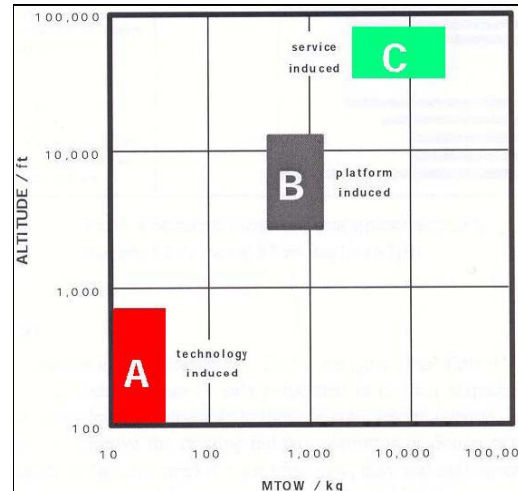

Figure 1. UAV civil classification (UAV Task-force)

2.3 Projects of UAV for Mobile Mapping

It is very difficult to display a complete overview of UAV for photogrammetric applications, because the interest in this field is in a beginning phase. The ISPRS set up a Working Group (WG 6) in commission V (2004-2008) with the goal to investigate the capacities of UAV in photogrammetry. At the 2004 ISPRS congress in Istanbul a few papers about UAV systems were presented: the Chinese Academy of Surveying and Mapping developed a mini UAV-aircraft used to extract from one image and a 2D GIS database 3D models of buildings (Wang, 2004). Moreover the Greece Topothec company produced a Zeppelin type balloon with a semi-metric Hasselblad camera for the survey of Archeological monuments. The ETH of Zurich has carried out a project for photogrammetric image data acquisition with a mini UAV-helicopter. The helicopter weighs 10 Kg and it is equipped with a GPS/IMU unit that allows to execute automated flights and photography shoots with E/O cameras. The system was tested in an archaeological area: it was carried out a semi-automatic bundle adjustment and the production of DTMs and ortoimages. The potentiality of MR-UAV and Mini-UAV systems has been arousing a strong interest also within the field of geomatics, for analysis and monitoring of natural or manmade damages. A research team of the Assiniboine Community of Manitoba (Canada) is developing a low-cost UAV digital imaging platform (CropCram UAV) for emergency response. The aircraft is commercially available and manufactured in Czech Republic by TopModel CZ. It has a 2.54 m wingspan and a weight of 2.72 Kg, including a digital camera Pentax optio S5i.

In Italy none of these systems have been commercialized yet, but various fix-wing UAVs are in a high development stage. An example is represented by the MR-UAV, designed by the University of Bologna, that has a 3.53 m wingspan and a max 5 kg payload, including EO/IR sensors and a telemetry system to accomplish flight attitude control.



Figure 2. The “CropCam” mini-UAV

These studies shows that UAV-systems in photogrammetric applications are quickly increasing. The technological development of navigation systems allows the reduction of costs and the miniaturization of payloads. It is afterwards possible to set up projects based on “low cost” platforms. Furthermore GPS/INS unit allows to control the attitude of flight according to a pre-programmed flight path and supplies rough external orientation parameters. These information could be used to reduce the number of ground control point required for the aerial triangulation. It is therefore possible to develop photogrammetric applications for the production of real-time maps at medium and large map scale. A quickly and completely automated production of maps using “low cost” mini-UAV is an important goal in the field of monitoring and analysis of damaged areas. MMT terrestrial systems are not suitable for these purposes, while aircraft and helicopter surveys are too expensive and could be hampered by the adverse weather. The dimension of overlooked areas depends on the performances of the vehicle, in particular to the optimum range/endurance limits. These aspects, with the choice of the sensors and navigation systems must be considered in the first stage of the project, in relation to the range of applications.

3. THE UAV “PELICAN”

The UAV “Pelican” is developed within the ITHACA project, with the main goal to carry on operational and research activities in the field of geomatics for analysis, evaluation and mitigation of natural and manmade hazards.

Different projects are in progress, namely the creation of basic and thematic maps for emergency management in remote or flood-affected areas. If satellite data are not available or not suitable to supply radiometric and geometric information, in situ missions must be foresaw. To this purpose ITHACA has developed a “low cost” mini-UAV. “Pelican” is a remote-controlled aircraft equipped with a GPS/IMU navigation system and different photographic sensors suitable for digital photogrammetric shootings with satisfying geometric and radiometric quality. It can be easily transportable on normal aircrafts and usable on the field by a couple of operators.

The main goal of this project is to evaluate and optimize the performances of the aircraft and the sensors, in order to develop a fleet of UAVs available for each worldwide emergency.

3.1 From MH2000 to PELICAN prototype

For a long time a research group within the Department of Aerospace Engineering (DIASP) of the Politecnico di Torino, led by Prof. F. Quagliotti and G. Guglieri, has been engaged in planning and implementing a mini-UAV for reconnaissance and monitoring civil applications. In particular, 2004 saw the presentation of the model MicroHawk 600, an aircraft with a 600 mm wingspan, transportable in a rucksack and made operational within few minutes by a single operator. Since then bigger versions were foreseen (MH 1000 and MH 2000, with reference to their wingspan in millimetres), our attention turned to the bigger model, due to the payload that ITHACA needs require (about 1,5-2 kg). Hence, the commissioning for the realization of the prototype Pelican (see Figure 3) and, in October 2006, the first test flights for the vehicle and some onboard equipment, with very satisfying results.



Figure 3. Views of the UAV prototype ITHACA 01



Figure 4. The UAV prototype ITHACA 01 during the first test flight

The platform MH2000 is characterized by a conventional configuration: fixed wing, tailless integrated wing-fuselage, tractor propeller driven, all-electric power. The fixed-wing

configuration gives the aerial vehicle a better capability of withstanding adverse weather conditions, such as gusts, and, besides, it allows larger payload capabilities and a superior flight performance. The main geometric dimensions and peculiar features of the platform are synthesized in table 2.

Specifications	ITHACA 01
wing span	2000 mm
Wing surface	2.1 m ²
Length (fuselage)	1750 mm
Width (fuselage)	150 mm
Payload weight	6,7 kg/m ²
Weight (body)	10 kg
Max take-off weight	14 kg
Payload	2,5 kg (25%)
Lithium-ion batteries	1,0 kg (10%)
Motor	0,5 kg (5%)
Motor model	Hacker C50-21 XL
Output power	2 hp @ 6600 rpm
Propeller	APC 16"x 8"
Min speed	8 m/s (29 km/h)
Max speed	20 m/s (72 km/h)
Optimum range limits	25 Km
Optimum endurance limits	1 h

Table 2. The Pelican technical specifications

3.2 Navigation system: MP2128^g autopilot

The aircraft is equipped with the MP2128g autopilot that allows autonomous flights and provides a real-time attitude of flight. The MP2128g is composed by an electronic circuit board and a ground control software (HORIZON^{mp}). The first component has a dimension of 100x40x15 mm³ with a weight of 28 g (Figure 5). It includes a GPS unit and antenna, three-axis gyroscope and accelerometer (IMU), relative airspeed probe, pressure altitude transducer, AGL ultrasonic altitude sensor, and external servo board. The gyroscope, accelerometer, pressure altitude transducer and airspeed probe provide feedback at 5Hz, GPS has 4 Hz update rate. 2.4 GHz radio modem allows to transmit the flight attitude to the Ground Control Station (GCS). The software HORIZON^{mp} (Figure 5) provides flight path and current sensor values in real-time. Therefore is possible to perform autonomous flight, excluded the operations of take-off and landing that must be accomplished manually due to the insufficient GPS height accuracy.

The operator can insert a flight plan (up to 1000 waypoints) on a preloaded map and upload them during the flight. Besides the system can be connected with the payload cameras, so it is possible to schedule an automatic shooting time. Therefore it is possible to carry out automated photogrammetric flights at half of the optimum range limits (within a range of about 25 km).

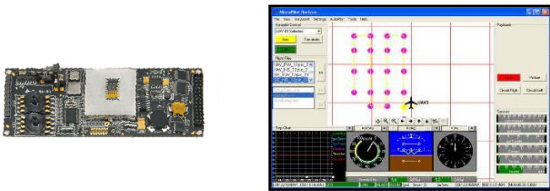

Figure 5. The MP 2128^g autopilot and the HORIZON software

Radio-communication is critical. It makes use of directional antennas, requires high power, in contrast with many national and international regulations, and will constitute the object of research and development in the ambit of a collaboration with the Department of Electronics (DELEN) of the Politecnico di Torino and the Istituto di Ricerca sull'Ingegneria delle Telecomunicazioni e dell'Informazione (IRITI) of CNR, also present within the Politecnico di Torino.

3.3 Sensors: RICOH GR – CANON EOS 5D

The current configuration of the UAV allows to carry onboard digital photographic sensors. In detail, two digital on the shelves cameras have been identified: RICOH GR Digital and CANON EOS 5D.

The two cameras are mounted on a special container (pod, Figure 6) on the belly of the fuselage. For the first tests they were not connected with the MP2128, therefore photographs are taken by an electronic switch that can be radio-controlled.

The main technical specifications of the RICOH GR are: image resolution of 8 Mpixel and focal length of 5.9 mm. Its weight is only 200g (including battery and SD) and its dimensions (107 x 58 x 54 mm) allows to mount it in a “pod” with the long side of the format orthogonal to the fuselage axis.

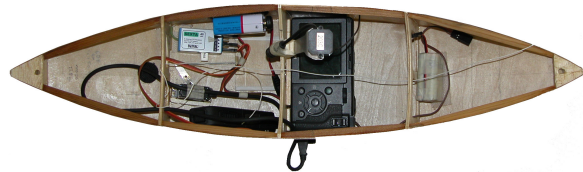

Figure 6. View of the “pod” with camera RICOH GR



Figure 7. Views of the camera RICOH GR digital

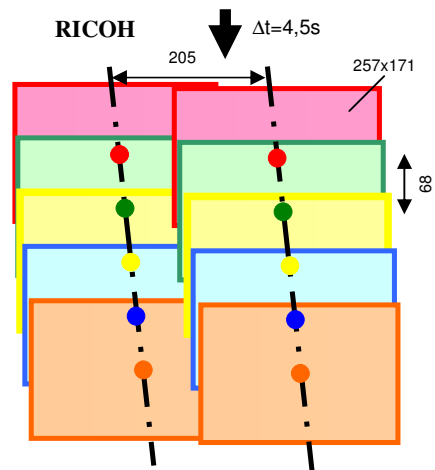

Figure 8. Flight plan RICOH GR (flight altitude = 200 m)

Furthermore at a flying altitude of 200 m and aircraft speed of 15 m/s it can perform flight strips with 75 mm ground pixel size, a 257 m side coverage and 4,5 s shooting interval with a 60% overlap along-track (Figure 8).

The CANON EOS 5D has better features than the RICOH GR such as high image resolution of 12.8 Mpixel, 1:1 sensor format (24 x36 mm) and an interchangeable lens. Concerning the last component, our attention has been turned to a “Nikkor AF 24mm f/2.8 D” wide angle lens. The full system size is bigger than the RICOH’s (Figure 9) and its weight is 1020 g. It is mounted with the long side of the format parallel to the fuselage axis. At a flying altitude of 200 m the side coverage is then 200 m, while the shooting interval is 8 s (speed 15 m/s - 60% overlap along-track) as shown in Figure 10. Ground pixel-size is 69 mm.



Figure 9. Views of the camera CANON EOS 5D

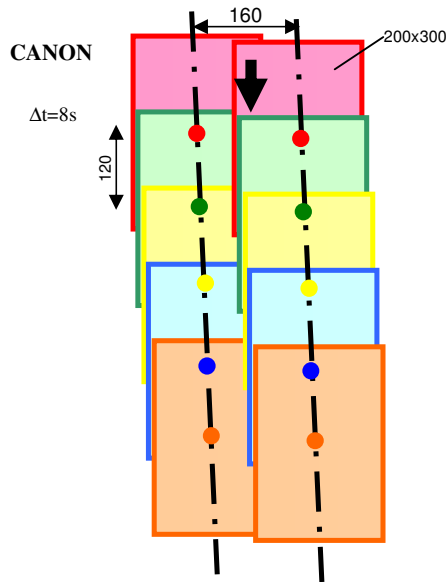

Figure 10. Flight plan CANON 5D (flight altitude = 200 m)

On the top of both the cameras’ displays a small video camera is mounted; it transmits the images to the ground in real time and records the shooting instant (when the display darkens).

In order to use non metric digital cameras for photogrammetric purposes it is necessary to estimate their Interior Orientation Parameters (IOP). Our research team has developed an suitable calibration tool. A stereo- pair has been acquired over a test field made of 30 target points. Then the software “Calibra” allows to estimate IOP performing the bundle adjustment of the stereo-pair. Radial, tangential and affinity coefficients that model the lens distortions are calculated. CANON EOS 5D camera calibration has given satisfactory results, due to the good features of the optical lens and the stability of the sensor.

RICOH GR calibration was instead tricky due to the movement of the optical lens during the switching on/off.

Specifications	RICOH GR	CANON EOS 5D
Focal length	5.9 mm (28 mm in the format 24 x 36)	24 mm Interchangeable
Sensor type	CCD	CCD
Sensor size	1/1.8” (7.18 x 5.32 mm)	24 x 36 mm
Max Image resolution	8 Mpixel (3264 x 2448)	12.8 Mpixel (4368 x 2912)
Video resolution	320 x 240 pixel	-
Optical zoom	No	No
Memory	SD up to 2 Gb	CF up to 4 Gb
Battery	Lithium-Ion rechargeable	Lithium-Ion rechargeable
Aperture range	F2.4 / F11	F2.8 /F22 (Nikkor 24 mm)
Max shutter	1/2000 sec	1/8000 sec
Dimension	107 x 58x 54 mm	152 x 113 x 75 mm
Weight (including battery)	200g	1050g

Table 3. ITHACA 01 technical specifications

4. TEST FLIGHTS

The aim of “Pelican” is to perform photogrammetric surveys in remote and affected areas, where it is not possible to carry out traditional photogrammetric flights. This acquisition technique allows to update existing maps and to produce thematic maps: 3D updating is made possible thanks to the stereoscopic coverage of the area. The main goal of the project is a complete automation of the whole process of flight image acquisition and data processing, in order to carry out large scale maps in near real-time.

Three test flights were performed in the Villareggia test site (Turin - Italy). They allowed to evaluate the capacities of the UAV platform and the geometric and radiometric performance of the sensors. The Autopilot MP2128 was not available yet, so flight tests were done by ground manual radio control. The attention was focused on the second test (October 2006), when flight planning, image acquisition, triangulation and orthoimage production were carried out.

4.1 Flight planning

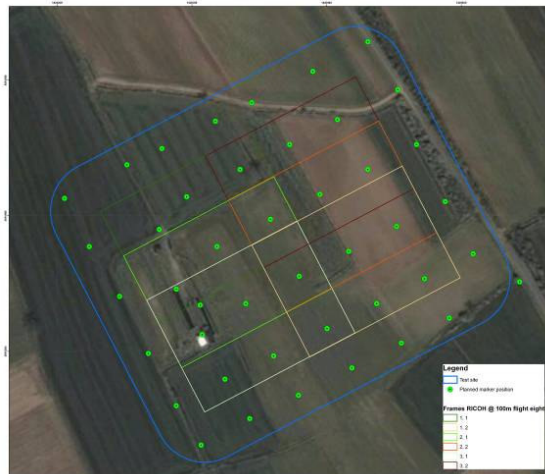

Figure 11. Flight plan on the test site of Villareggia

The flight planning relative to the Villareggia test site has been performed according to RICOH GR digital camera technical specifications. At a flight altitude of 100 m the side coverage is 125 m, while the shooting interval is 2.5 s (considering a speed = 15 m/s and a overlap = 60%). Ground pixel-size is 38 mm.

The area of interest is covered by a block of 2 strips with 3 frames each as shown in Figure 11.

The used GCP are represented by 42 target points covering the whole test area. These targets have been built according to the results of several tests aimed at defining the optimal size, shape and colour. 30x30 cm black and white square shaped targets were chosen considering a maximum operational distance of about 200 m (see figure 12).



Figure 12. Views of target point

The planimetric and height coordinates of the targets have been surveyed using a total station Topcon GPT 8201.

4.2 Image acquisition

Frames have been acquired through a remote radio controlled system based on a twin microswitch card interfaced with the digital camera shooting command. This system allows to set a shooting time interval: through the remote control the operator trigger the first acquisition.



Figure 13. Frames used for the aerial triangulation

The lack of an on-board automatic navigation system caused some problem during the in flight images acquisition. The scarce platform stability (a few pictures are blurred due to the

rolling effect), the radio transmission interferences and the illumination problems, allowed to acquire only 3 images suitable for the photogrammetric process. The frames were acquired at a flight altitude of 150 m and have an image scale of 1:25000 (Figure 13).

4.3 Image processing

The triangulation was performed using the Leica Photogrammetric Suite software through the frame camera rigorous model. Interior orientation was done using the IOP supplied by the software “Calibra”. The measurement of tie point and control point were carried out manually.

In the bundle block adjustment 14 targets are used as GCP and 4 targets as CP. Table 4 highlights the results of aerial triangulation.

	Control Point RMSE	Check Point RMSE
Ground X (m)	0.07	0.10
Ground Y (m)	0.07	0.13
Ground Z (m)	0.08	0.30
Image x (pixel)	0.90	2.61
Image y (pixel)	0.79	0.72

Table 4. LPS report of aerial triangulation

The achieved accuracy is lower than the expected one (estimated using the collinearity equation under hypothesis of normal acquisitions), mainly due to the camera calibration problem and the flight instability above described

CONCLUSION

First results concerning the performed photogrammetric tests are encouraging, since the achieved accuracy, although lower than the theoretical one is more than suitable for early impact applications.

At the moment new tests have already been planned in order to verify the performances of the installed MP2128^s Micropilot autopilot. The expected improvements are mainly connected to:

- the capability of following the flight-plan with higher accuracy;
- the higher image quality due to the major stability of the platform.

A planned development of this research is to realize a software for rapid mapping purposes obtained using a “direct photogrammetry” approach.

REFERENCES

International UAV Community, 2006. *Referenced UAV systems*. UAV SYSTEMS: Global Perspective 2006, pp.171. www.uvs-info.com (accessed February 2007).

JAA/EUROCONTROL, 2004. *UAV Task Force Final Report, a concept for European regulations for civil unmanned aerial vehicles (UAVs)*, pp. 5.

Eisenbeiss H., 2004. *A mini unmanned aerial vehicle (UAV): system overview and image acquisition* International Workshop on “Processing and visualization using high-resolution imagery”.

Lewis G., 2006. *Evaluating of use of a low-cost unmanned aerial vehicle (UAV) platform in acquiring digital imagery for emergency response*. Manitoba, Canada.