

Latency and Simulation Stability in a Remote Power Hardware-in-the-Loop Co-simulation Testbed

Original

Latency and Simulation Stability in a Remote Power Hardware-in-the-Loop Co-simulation Testbed / Bompard, E., Bruno, S., Cordoba-Pacheco, A., Diaz-Londono, C., Giannoccaro, G., La Scala, M., Mazza, A., Pons, E.. - In: IEEE TRANSACTIONS ON INDUSTRY APPLICATIONS. - ISSN 0093-9994. - ELETTRONICO. - 57:4(2021), pp. 3463-3473. [10.1109/TIA.2021.3082506]

Availability:

This version is available at: 11583/2913772 since: 2021-10-28T15:36:00Z

Publisher:

Institute of Electrical and Electronics Engineers Inc.

Published

DOI:10.1109/TIA.2021.3082506

Terms of use:

This article is made available under terms and conditions as specified in the corresponding bibliographic description in the repository

Publisher copyright

IEEE postprint/Author's Accepted Manuscript

©2021 IEEE. Personal use of this material is permitted. Permission from IEEE must be obtained for all other uses, in any current or future media, including reprinting/republishing this material for advertising or promotional purposes, creating new collecting works, for resale or lists, or reuse of any copyrighted component of this work in other works.

(Article begins on next page)

Latency and Simulation Stability in a Remote Power Hardware-in-the-Loop Co-simulation Testbed

Ettore Bompard, *Member, IEEE*, Sergio Bruno, *Member, IEEE*, Andres Cordoba-Pacheco, Cesar Diaz-Londono, *Member, IEEE* Giovanni Giannoccaro, Massimo La Scala, *Fellow, IEEE*, Andrea Mazza, *Member, IEEE* Enrico Pons, *Member, IEEE*

Abstract—The modern applied research requires multi-disciplinary approaches and can be effectively enriched thanks to the close collaboration of universities’ and industries’ working teams. This kind of collaboration implies sharing of hardware and software facilities, and profitable contamination of knowledge and expertise among the members of the different teams. In the power system field this kind of approach may result into a remote connection allowing the coupling (and thus the share) of real-time simulators located in different laboratories. This paper describes in detail an experimental testbed (consisting of the interconnection of two real-time simulators, located at Politecnico di Torino and Politecnico di Bari, at a geographical distance of 1,000 km) in order to perform remote Power Hardware-in-the-Loop experiments. The possibilities and limitations of this type of co-simulation are described and a case study is presented. Finally, the specific problems related to communication latency and simulation stability are analysed and discussed.

Index Terms—Real Time Simulation, Geographically Distributed Simulation, Microgrids, Power System Laboratories, Labs-in-the-network, Knowledge contamination.

I. INTRODUCTION

THE installation of non-controllable power plants exploiting Renewable Energy Sources (RES) introduced new challenges in power system planning and operation. Currently, the future development of the electrical power system is described by using two opposite paradigms, based on either the implementation of supergrids [1], or on the capillar diffusion of microgrids [2]. In the first approach, the system will be reinforced with the expansion of the transmission system, whereas, in the latter case, it will be based on the wider and wider use of autonomous communities. Both cases require the use of new devices that need to be tested before their installation to verify their compliance with standards in different grid conditions. The reiteration of particular tests, deriving from defined network conditions, can be really tough, especially in case of complicated phenomena applied to different devices under test.

All the above issues pushed different European institutions to share their knowledge and their research infrastructures,

S. Bruno, G. Giannoccaro and M. La Scala are with the Department of Electrical and Information Engineering (DEI), Politecnico di Bari, Bari, 70125 Italy, e-mail: (sergio.bruno@poliba.it, giovanni.giannoccaro@poliba.it, massimo.lascalas@poliba.it).

E. Bompard, A. Cordoba-Pacheco, C. Diaz-Londono, A. Mazza and E. Pons are with the Energy Department “Galileo Ferraris” (DENERG), Politecnico di Torino, Torino, Italy, e-mail: (ettore.bompard@polito.it, andres.cordoba@polito.it, cesar.diazlondono@polito.it, andrea.mazza@polito.it, enrico.pons@polito.it).

by implementing the so-called *laboratories-in-the-network* framework [3], [4]. This framework is based on geographically distributed simulation (GDS), and allows to combine the capability of different research facilities to perform simulations of complex systems and scenarios. One of the peculiar aspect of this approach is that it exploits Real Time Simulation (RTS), making simulations involving real hardware devices installed in different locations possible [5]. The advantages from this kind of approach are [6]:

- soft sharing of hardware and software facilities within a federation of laboratories;
- testing of devices by integrating remote Power Hardware-in-the-Loop and remote Software-in-the-Loop;
- enhancing simulation capabilities for large systems;
- keeping confidential susceptible data, models or algorithms.

The implementation of GDS infrastructure allows to enlarge the application fields of RTS, and makes it competitive with other off-line power system software (basically because of the possibility of connecting real devices).

The idea of using GDS in power system domain firstly appeared in [7], whereas the first implementations were shown in [8] [9]. An example of this kind of infrastructure is the ERIC-Lab [10], which was implemented with the aim of making the co-simulation among the laboratories of Politecnico di Torino (Italy), RWTH Aachen University (Germany), JRC Petten (The Netherlands) and JRC Ispra (Italy) possible. Another successful demonstration is the RT-Superlab, which allowed to connect together Research Institutes widespread between Europe and US [11]. Another example is the one reported in [12], where a trans-pacific (US-Australia) real time closed-loop simulation platform connecting a power network simulator with a physical PV/battery inverter is shown. It permitted to co-simulate slow dynamic phenomena with a simulation time step of 2 s.

Different methodologies have been applied for interconnecting the different laboratories or devices. The platform proposed in [13], for example, takes advantage of internet-of-things (IoT) communication systems and protocols, such as for example MQTT, to enable the interoperability among different devices and simulators. In [14], a cross-infrastructure platform has been set up in order to interconnect a real SCADA system, a real-time simulator and Power Hardware-in-the-Loop devices located in different premises. In this case different communication schemes and

protocols have been tested, starting from field devices level (e.g. Modbus), up to application level (e.g. UDP or TCP over IP).

In a previous work, the Authors had set-up an experimental test-bed in which two Italian technical universities, namely Politecnico di Bari (PoliBa) and Politecnico di Torino (PoliTo), interconnected their physical laboratories located across the Italian peninsula at a distance of approximately 1,000 km [15]. The availability of a real microgrid interfaced to a Power Hardware-in-the-Loop (PHIL) facility at PoliBa, together with the high computation capability proper of the simulator at PoliTo, opens the possibility to exploit these two features to simulate large systems (decoupled between the two real time simulators), with a real microgrid connected. This kind of implementation is known as remote Power Hardware-in-the-Loop (R-PHIL): some examples of R-PHIL may be found in literature, for example aiming to characterize remotely devices under tests (such as electrolysers, as shown in [16]), but also for testing power management systems in microgrids (such as the example reported in [17]).

In general, the R-PHIL implementation requires the exchange of electrical variables between two laboratories through internet. In this paper, this is achieved by resorting to a Virtual Private Network (VPN) and adopting UDP protocol for communication. A non-linear power amplifier is used to replicate the network conditions simulated at PoliTo on the real microgrid in PoliBa, while the load conditions in the real microgrid in PoliBa impact the network simulation in PoliTo.

Studies such as [18], have shown how large communication latency could lead to numerical inaccuracies, or even to misleading results, and how these latencies can be corrected by using a linear prediction method. A quite recent study analyzing the effect of the latency in the framework of the GDS is [19]: in the paper, the real-time communication tool called JaNDER, developed within the EU project ERIGrid [20] [21], was tested in a configuration involving an industrial On-Load Tap Changer and a portion of Low-Voltage (LV). The results showed the feasibility of the approach, being the latency lower than 300 ms and thus not affecting the results.

In [22], the Authors have observed through an extensive set of communication tests the factors which influence the communication quality in terms of latency and number of lost packets. In the current paper the purpose is to analyze the impact that latency has on stability and accuracy of the R-PHIL simulation.

The rest of the paper is organized as follows: Section II describes the infrastructure parts (i.e., the microgrid, the simulation facilities and the communication), while Section III shows the experimental results. In particular, Section III-A demonstrates why it is not possible to exchange electric variables using the instantaneous values, thus a more wise approach is required; Section III-B presents the case studies, with a comparison between local and remote Power Hardware-in-the-Loop tests, with the natural latency; and Section III-C describes the stability studies. Finally, Section IV provides the concluding remarks.

II. CO-SIMULATION POWER HARDWARE-IN-THE-LOOP ARCHITECTURE

The paper presents the results of the setting up of a remote Power Hardware-in-the-Loop (R-PHIL) platform, based on remote real time co-simulation. The two interconnected laboratories are located in Bari (Southern Italy) and Turin (Northern Italy) and their air distance is about 1,000 km.

A. Politecnico di Bari - LabZERO

The PHIL test facility at the Politecnico di Bari (PoliBa) is located in the public research laboratory LabZERO [23] [24]. The facility is composed of a real time digital simulator that communicates bi-directionally via optical fiber with a 16 kVA 4-quadrants programmable power source. The power source has a 6-channel power output that is currently configured for a 4-wire AC connection. The controllable power output can be used either to locally feed a bank of resistors, inductors and capacitors, and/or to exchange power with a microgrid.

The LabZERO microgrid, located about 120 m from the lab, is composed of several distributed energy resources such as a PV generator, a wind micro-turbine, a 4-quadrants battery energy system, a 11 kW charging station for electric vehicle and a small scale biomass combined cycle generator. The microgrid can be either connected to the main grid or work in island mode. When it is operated in island mode, the programmable power source can be controlled with a grid-forming scheme, providing voltage and frequency reference to the entire system.

All microgrid energy resources are monitored and controlled by a SCADA system via Modbus TCP/IP. However, due to the time delays introduced by Modbus communication (around 100 ms for each master-slave polling) and the time resolution of the energy meters (1 s), power measurements at SCADA will not be used at this stage in the co-simulation platform.

B. Politecnico di Torino - G-RTSLab

G-RTS Lab, at Politecnico di Torino (PoliTo), is an internationally interconnected lab for real-time simulation. It is active in studying the role of electricity in energy transition, as well as new smart grid and super grid layouts for electricity infrastructures. The activities of the G-RTS Lab are integrated into the Energy Center Lab (EC-Lab), where interdisciplinary studies related to different energy sectors (e.g., electricity, gas and heat) can be studied entirely.

The facility is composed by a real time digital simulator with 7 activated cores and the possibility to perform both EMT simulations (with networks composed of 300 three-phase nodes) and simulations employing the phasor domains (with networks with at most 30,000 nodes).

C. Remote PHIL (R-PHIL) co-simulation architecture

The co-simulation architecture was designed in order to integrate the dynamic response of the PoliBa microgrid in the simulation of a larger electrical power system.

The design of the platform considered some relevant aspects of the existing communication link established between the

two real-time simulators in Bari and in Turin. The two machines have been connected establishing a VPN tunnel and employing an IPsec encryption key to achieve communication security. The two machines exchange data using asynchronous messaging and UDP protocol.

As it will be shown in the next paragraphs, although the assessed communication performances are impressive (about 12 ms for each one-way transmission), **due to the adoption of asynchronous messaging with a real-time transport layer protocol (i.e. UDP), which does not guarantee the proper message delivery, and due to the unavoidable latencies necessary to cover the distance between the two remote locations, the use of real-time voltage or current waveforms is not suitable to couple the two remote simulated systems. Complete or distorted voltage waveforms cannot be fed to the programmable power source for security reasons and to avoid stress to the hardware equipment. For these reasons, the R-PHIL platform adopts averaged signals, such as power measurements or voltage magnitudes, to exchange data between the remote real-time simulators.**

Although the adoption of UDP protocol yields some limitations, it certainly guarantees other advantages. For example, in the case of data loss, it ensures that missing and delayed packets are ignored and only most updated data are used [25]. According to the experimental results recalled in the following Section, the communication of electrical variables using UDP packets at a slow rate (i.e., one packet at every cycle) and adopting suitable retransmission techniques, is secure enough in the established communication channel.

The proposed architecture assumes that each real-time machine (including the Target PC that controls the programmable power source) simulates a power system layer characterized by short-circuit power significantly lower than the layer above. **This means that a load variation in the lower layer produces small changes in the voltage of the upper layer.** If this assumption holds, it is reasonable to assume that the layer below can be controlled using V, f reference signals, whereas its response is fed back **to the upper layer** in the form of P, Q signals. **Furthermore, as the equivalent impedance of a layer is inversely proportional to its short circuit power, the above mentioned assumption can be rewritten as $Z_A/Z_B \ll 1$, where Z_A is the equivalent impedance of the upper layer and Z_B is the equivalent impedance of the lower layer. In this situation the co-simulation is stable and the stability margin is high, as suggested in [26], [27].**

The monolithic Local PHIL (L-PHIL) architecture in Fig. 1 is organized as described in the previous paragraph. In fact, the real-time simulation generates voltage and frequency references to be fed to the programmable power source. The programmable source operates in grid-forming scheme, by imposing such references on the microgrid and the other connected devices. The real-time response of these devices is measured and fed back, in the form of voltage and current waveforms, to the Target PC, which controls the programmable source. These waveforms are analysed in realtime by a custom measurement block, so that exchanged active and reactive power are known with sufficient precision at every cycle. This custom block was developed for the L-PHIL tests in [28] and

allow to obtain accurate power measurements also in the case of significant frequency deviations from the 50 Hz nominal value.

The L-PHIL architecture in Fig. 1 can be slightly modified, as in Fig. 2, to include the co-simulation of the network. This second architecture represents the co-simulation R-PHIL platform established between PoliTo and PoliBa. The two real-time digital simulators are responsible for the simulation of a portion of the grid, one for each simulator. The simulator that solves the network portion on a lower layer (or lower voltage level) receives voltage and frequency references from the simulator above and then gives back the exchanged active and reactive power at the point of common coupling between the two network portions.

This configuration can be used to exploit the computation capabilities of both real-time simulators, but also suggests the possibility to develop new forms of collaboration in research and testing, where hardware equipment can be shared remotely without the necessity of physically moving it. This means that, if for instance PoliTo needs to include in its simulations the dynamic behaviour of one or more of the devices that are employed at PoliBa (or viceversa), a remote PHIL communication can be established, allowing a physical share of power equipment.

Enabling and simplifying the share of equipment among public research laboratories is an important achievement that can allow to co-simulate and test more complicated systems, but also to reinforce national and international research collaboration and to enlarge the chances to exploit research equipment, by accelerating at the same time the return of investments on particularly expensive technologies.

III. EXPERIMENTAL RESULTS

A. Communication tests

The main communication challenge between two realtime systems is to guarantee data acquisition in order to provide reliable information to the connected actual power systems. A fundamental issue in co-simulation and R-PHIL is the data transmission delay (or latency), as it impacts the co-simulation stability. In order to assess the amount of lost packages and the quality of the data transmission, an initial loop-back communication test was carried out.

In a first test, a sine wave signal was generated by the simulator at PoliTo and sent to PoliBa using a $500\mu\text{s}$ sample time. This same signal was then sent back to PoliTo as soon as received. Using hardware synchronization mode, the generated signal and the one received at PoliTo were reproduced simultaneously as analog outputs of the digital simulator. These outputs were measured with an oscilloscope, as in Fig. 3. The blue signal is the original generated sine wave, whereas the teal signal represents the data received back at PoliTo. Thanks to the property of UDP protocol (permitting always the use of the most recent available data), the two sine forms are distanced by a constant delay even when few packets are lost.

The next step was to calculate the delay between the two waveforms. For this purpose, a disturbance (an offset

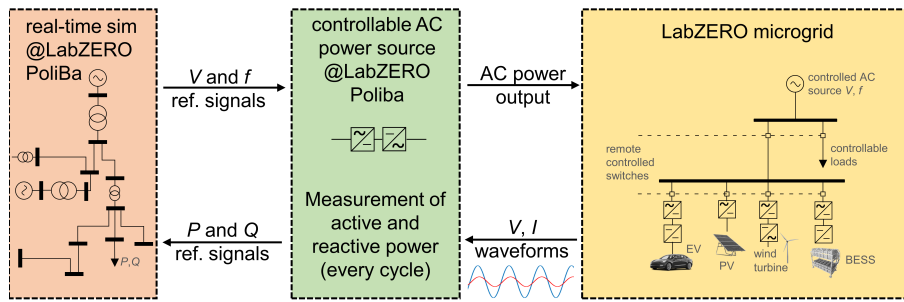

Fig. 1. Local PHIL (L-PHIL) architecture scheme, monolithic simulation

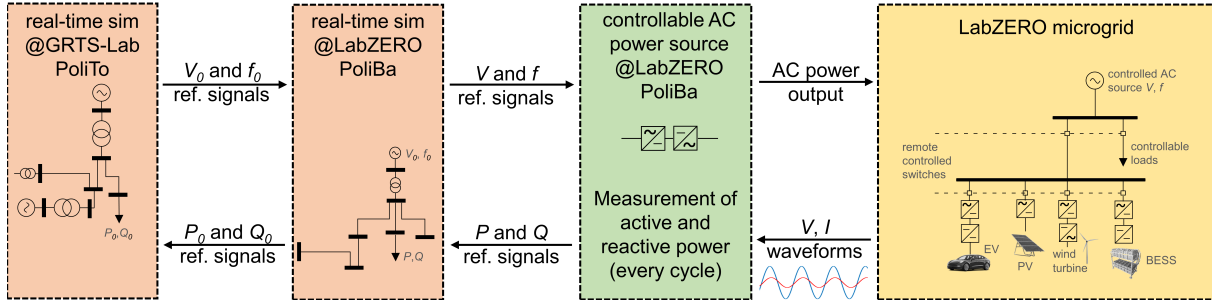

Fig. 2. Remote PHIL (R-PHIL) architecture scheme, network co-simulation

step-change) was applied to the generated sine wave. The detection of this same disturbance in the received signal permits to measure the time needed to move data from PoliTo to PoliBa and then back. Fig. 4 shows the sent and received signals as recorded by the real-time simulator at PoliTo. The blue waveform is the discretized signal sent by PoliTo whereas the red plot shows the data received from PoliBa and then received back at PoliTo. It can be noticed that the delay is larger than one period (i.e. 20 ms at 50 Hz) and that some data packets were lost.

The total delay (in loop-back) is 25 ms and thus, assuming that the delay does not change with the direction of the transmission, the delay associated with a single transmission is estimated in about 12.5 ms. This is an excellent result considering the distance of the two laboratories. In order to evaluate the quality of the transmission in terms of data loss and delay, the Total Harmonic Distortion (THD) of both signals and delay were averaged along a 24 cycles. The THD of the sent signal is about 0.11% and results much lower than the received signal's one, which is about 15.71%. This difference is basically due to the **delayed packets which have been considered lost** during data transmission. The high distortion in the received waveforms leads to exclude the direct use of the sine waves to remotely operate a power device, calling for a different approach (for instance, through dynamic phasors [29] or other electrical variables) so that the information content is in any case guaranteed.

Due to the properties of UDP real-time communication, with higher rates of data transmission, delayed packets are discarded (and considered lost) more often, since more recent packets have reached the receiving end-point first. This was observed in [22] through an extensive set of experimental communication tests. The notable result was that, due to

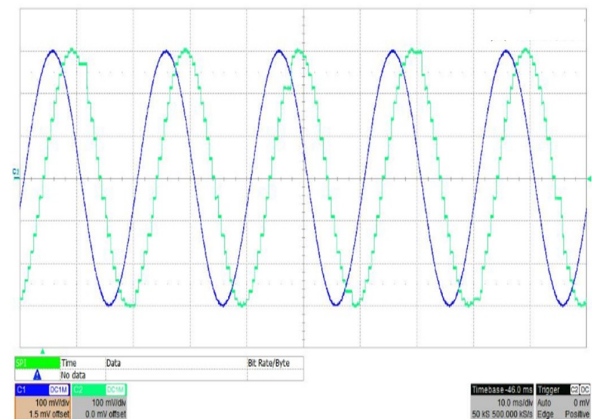

Fig. 3. Oscilloscope measurement of generated and received waveforms.

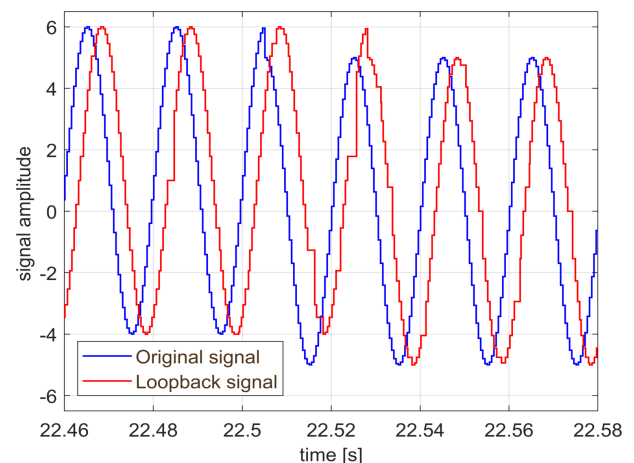

Fig. 4. Sinusoidal waveform sent and received.

the above mentioned UDP property, with a decrease of the communication rate the number of lost packet sensibly decreased but the average delay increased. Adopting a 1 ms sample time the number of lost packets was about 1%, dropping to less than 0.01% with a sample time higher or equal to 5 ms. The retransmission of the same UDP packet with a higher rate ensures the reduction of lost packets and, at the same time, limits transmission delays since delayed measurements can be substituted by recent retransmissions of the same value. In the proposed architecture, real-time power measurements from the hardware equipment are sampled and sent to the remote RTS at each cycle (every 20 ms), and then retransmitted every millisecond until a new measurement is acquired. This strategy impacts very little in the use of real-time computing resources, but ensures to control data loss and latency. To extent of this experimentation, no issues of data loss or transmission latency increase were observed.

B. Local and Remote Power Hardware-in-the-Loop tests

These experimental tests were carried out in order to compare the performance of the proposed R-PHIL co-simulation architecture (Fig. 2, where the network is decoupled) with respect to the L-PHIL one (Fig. 1, where the network simulation is not decoupled). In the L-PHIL test, the grid simulation is just carried out by the PoliBa digital simulator. Conversely, the R-PHIL test employs the PoliTo digital simulator for grid simulation, whereas the PoliBa one is used to i) pass the voltage and frequency (V, f) reference signals onto the programmable power source and ii) provide the active and reactive power (P, Q) measurements back to the grid simulation at PoliTo.

The programmable power source controls its output in grid-forming mode, according to the voltage and frequency references received from the digital simulator at PoliBa. The output is used to feed a resistive-inductive (R-L) adjustable load bank. The tests simulate the transients following several load step changes. Each step change is obtained by switching on/off the R-L load.

In order to allow for a comparison in terms of time response, the load switching is obtained through the control of a contactor by means of a programmable smart relay. The programmable smart relay activates/deactivates the contactor coil according to a digital signal received by the digital simulator at PoliBa. The digital simulator operates in hardware synchronized mode, so that it can provide the digital signal to the programmable logic relay at a specific instant. All trajectories are recorded using this signal for synchronization of the local machines.

In the tests presented in this subsection, a base nominal load of 192.9 W and 64.3 var (inductive) is always on, whereas the contactor allows to switch on/off an additional load of 450.0 W and 128.6 var (inductive). Since this load variation cannot realistically cause appreciable voltage deviations at the simulated grid side, the measured active and reactive powers are multiplied by a scale factor ($\times 100$) and then applied to the simulated grid.

The implemented electrical grid is shown in Fig. 5a) and represents a portion of a medium voltage (MV) system

of the city of Turin. This network has one feeder derived from a 22 kV busbar of a 220/22 kV primary substation and operates at $f=50$ Hz [30]. The nominal power of the HV/MV transformer is $S_n = 55$ MVA and the connection of the windings is star-star (Y-y). The studied feeder is composed of eight MV/LV substations; the MV/LV transformer and the real hardware are connected to the last substation of the feeder.

The loads of the simulated network are modeled as equivalent loads directly connected to the MV distribution system, except in one node where the MV/LV transformer and a portion of the LV network are represented in detail. In the R-PHIL test the system is decoupled in correspondence of this MV/LV transformer: the MV distribution network is simulated at PoliTo, whereas the LV feeder at PoliBa. The green arrow of Fig. 5a) represents the virtual connection between the two sites: as already specified, the communication is based on a VPN connection which allows exchanging the electrical variables bi-directionally, as detailed through a simplified single-phase equivalent circuit of the co-simulation approach in Fig. 5b).

In general, the proposed architecture is suitable for studying phenomena involving voltage, current and frequency dynamics, as shown in [28]. However, R-PHIL simulations of transient phenomena with rapid frequency fluctuations have been considered out of the scope of this experimentation. In fact, due to the assumption made in the network model, power variations in the LV network (and therefore in the connected hardware) cannot modify the frequency of the MV/LV grid, which is modelled as fed by an equivalent slack generator with fixed voltage and frequency. Even though, for the sake of completeness, a frequency signal is passed onto the LV and PHIL simulation, all simulated subsystems are isochronous and working at a constant frequency.

The tests performed and presented in this work focused on the analysis of voltage and current dynamics caused by real time changes in the load. Numerous tests were carried by switching the additional load on and off using both L-PHIL and R-PHIL implementation. In all tests, not shown here for the sake of brevity, the voltage response was stable. Both L-PHIL and R-PHIL tests showed comparable voltage and power transients, as well as same initial and final steady-state values. Although the voltage transients cannot be fully replicated in L-PHIL and R-PHIL tests, similar time responses have been studied and compared in the followings. The plotted transients reproduce the L-PHIL and R-PHIL response in the case of upward and downward step load variations. Please note that the acronyms BA and TO will be used in the figure captions to identify PoliBa and PoliTo, respectively.

Fig. 6 shows the voltage time response together with the active power measured at the programmable source, in the case of a downward load step-change variation. The first load step change is usually experienced within about 3 cycles from the sending of the switching signal ($t = 0$ s). The power measurements are communicated as soon as a new estimation is available (i.e., at every cycle). The voltage response in the L-PHIL test (up) is very close to the one in the R-PHIL test (bottom), although the second one is delayed. It can be noticed

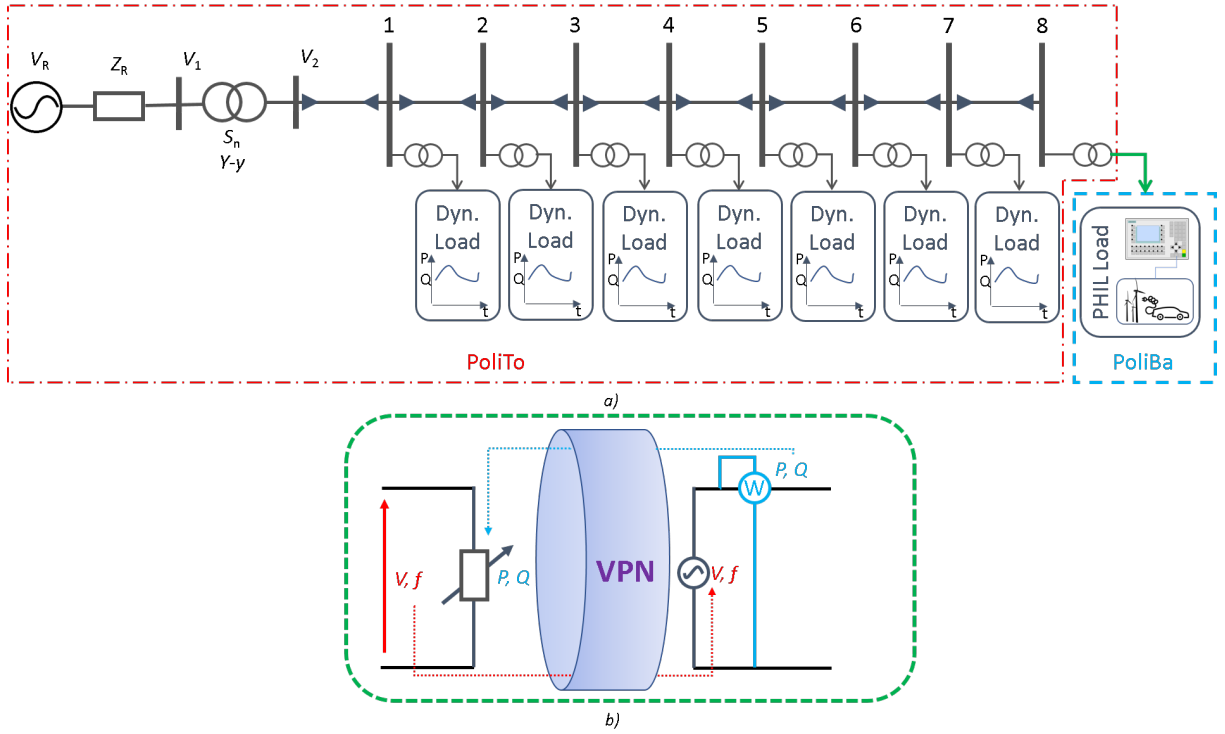

Fig. 5. a) Simulated MV grid portion and b) single-phase equivalent of the co-simulation approach.

that in the L-PHIL test the voltage transient starts as soon as a P, Q variation is communicated to the digital simulator. Conversely, in the R-PHIL test, the first voltage response is delayed by about 25 ms from the moment of the first P, Q variation. This is the cumulative time needed to send the power measurements to the PoliTo simulator and send the first voltage response back to PoliBa. In the remote test, the voltage plot has a lower time resolution because of the sample time used for transmission of the V, f signal from PoliTo. Same results and behaviour can be observed comparing the responses to an upward load step variation (see. Fig. 7).

This result is consistent with the communication time delay assessed in the previous tests (Section III-A) and is also confirmed by the recordings of voltage and power at both locations (PoliBa and PoliTo).

As represented in both Fig. 8 and Fig. 9, the power step change measurement is received at PoliTo with a delay of about 12.5 ms. The subsequent voltage transient is then communicated to PoliBa with an equivalent delay. The figures also permit to appreciate the difference between the simulated voltage trajectory and the one received (with delay) at PoliBa. Considering that the transmission from PoliTo is asynchronous and the sampling rate for the transmission was set at one sample every 3 ms, the two voltage trajectories appear sufficiently similar.

Figs. 10 and 11 compare the voltage and the power trajectories recorded at PoliBa (during the L-PHIL test) and PoliTo (during the R-PHIL test). The objective of this comparison is to analyse the impact of PHIL on the simulated network. The main features referring to these two step responses are reported in Table I and Table II, respectively.

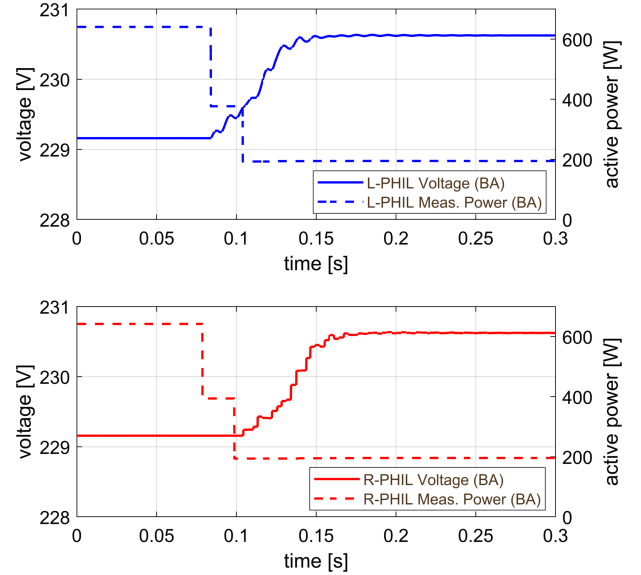

Fig. 6. Voltage and active power trajectories recorded at PoliBa for a downward load step variation: L-PHIL test (up) and R-PHIL test (bottom)

These features have been evaluated by feeding the recorded trajectories to the *step info* Matlab tool.

The dynamic responses in the local and remote tests appear to be very similar in terms of steady-state values, overshoot and settling times (calculating the settling time from the moment that a P, Q variation is recorded and with a 2% band around the steady-state value). This proves that the proposed methodology allows to reproduce with good approximation the response of the physical system on the simulated remote

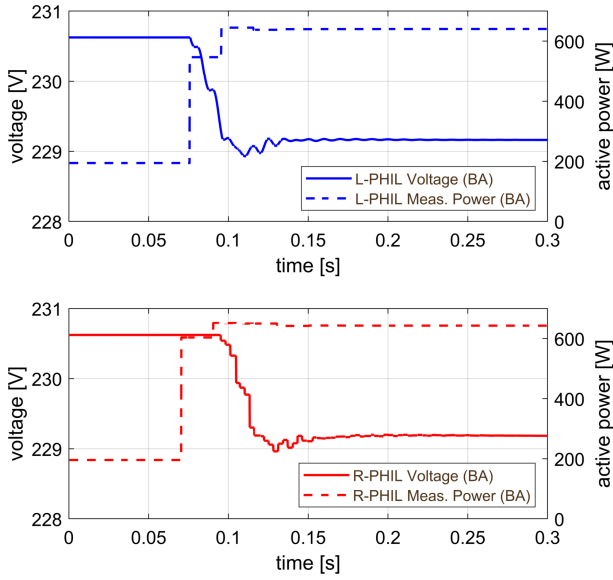

Fig. 7. Voltage and active power trajectories recorded at PoliBa for an upward load step variation: L-PHIL test (up) and R-PHIL test (bottom)

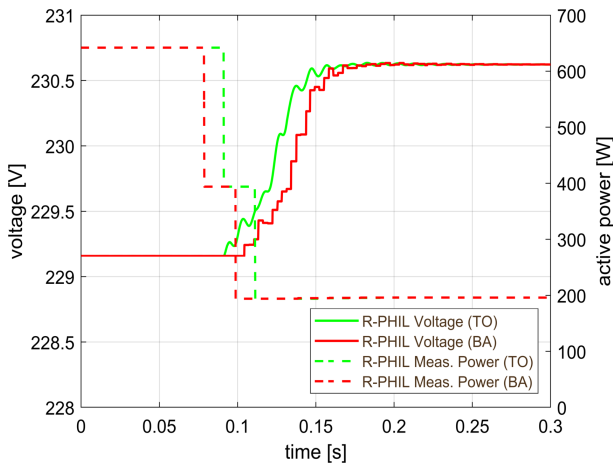

Fig. 8. Voltage and active power trajectories recorded at PoliTo and PoliBa during the R-PHIL test (downward load step variation)

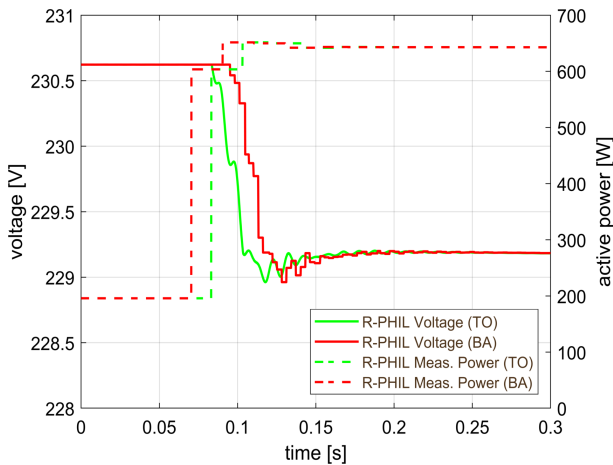

Fig. 9. Voltage and active power trajectories recorded at PoliTo and PoliBa during the R-PHIL test (upward load step variation)

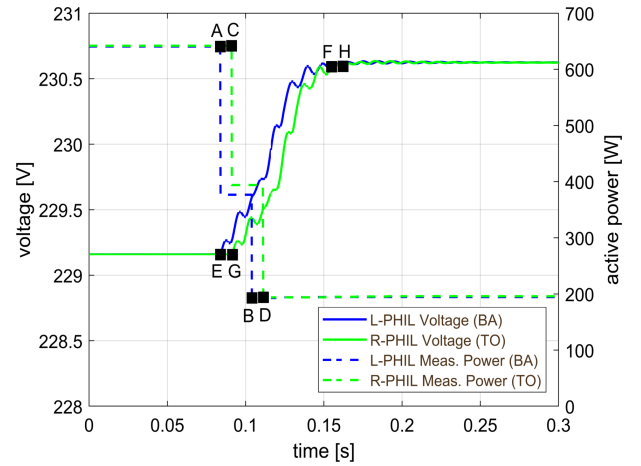

Fig. 10. Voltage and active power trajectories recorded at PoliBa (L-PHIL test) and PoliTo (R-PHIL test), for a downward load step variation

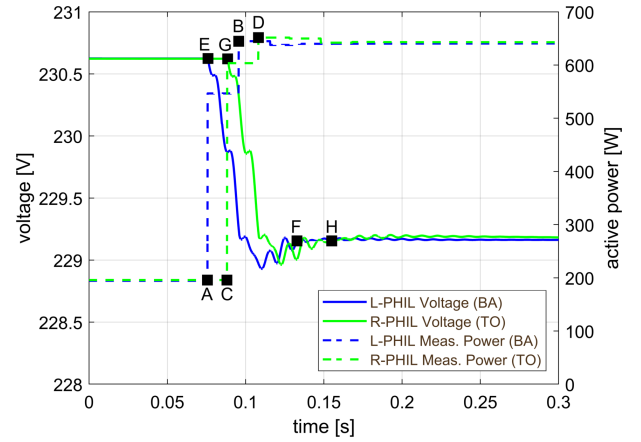

Fig. 11. Voltage and active power trajectories recorded at PoliBa (L-PHIL test) and PoliTo (R-PHIL test), for an upward load step variation

network. The only appreciable difference is in the unavoidable delay due to the transmission. This delay can affect the accuracy of simulations that require short time resolutions (for example EMT simulations for short-circuit studies); however, it is small enough to allow a suitable description of transients and regulators that are characterized by slower time responses (voltage regulation, electromechanical transients, load and generation shedding, etc.).

C. Impact of communication latency and stability of simulations

Further tests have been carried out in order to assess what is the impact of communication latency on the proposed co-simulation architecture. In [22], the authors have already demonstrated, through an extensive set of communication tests with different sampling periods and payload sizes, that latency between PoliBa and PoliTo seldom exceeds 15–20 ms. Moreover, thanks to the properties of the UDP protocol, it was shown that latency distribution can be tightened around the average value of about 12.5 ms by sending the same message multiple times at a higher rate (for example one packet every millisecond) without any appreciable impact on real-time

TABLE I
STEP-INFO ANALYSIS - DOWNWARD LOAD STEP

Response features	Loc.Voltage (BA)	Rem.Voltage (TO)	Local Power (BA)	Remote Power (TO)
Peak	230.63 V	230.63 V	192.8 W	193.9 W
Peak Time	0.1850 s	0.1827 s	0.1040 s	0.1113 s
Initial Value	229.16 V	229.16 V	640.7 W	641.9 W
Settling Value	230.62 V	230.62 V	194.5 W	195.9 W
Initial Time	$t_E=0.0840$ s	$t_G=0.0970$ s	$t_A=0.0838$ s	$t_C=0.0963$ s
Settling Time	$t_F=0.1545$ s	$t_H=0.1623$ s	$t_B=0.1040$ s	$t_D=0.1113$ s
Overshoot	0.6%	0.81%	0.38%	0.44%

TABLE II
STEP-INFO ANALYSIS - UPWARD LOAD STEP

Response features	Loc.Voltage (BA)	Rem.Voltage (TO)	Local Power (BA)	Remote Power (TO)
Peak	228.93 V	228.96 V	644.8 W	651.5 W
Peak Time	0.0110 s	0.1228 s	0.0956 s	0.1882 s
Initial Value	230.62 V	230.62 V	194.4 W	195.8 W
Settling Value	229.16 V	229.18 V	640.6 W	642.9 W
Initial Time	$t_E=0.0759$ s	$t_G=0.0885$ s	$t_A=0.0755$ s	$t_C=0.0880$ s
Settling Time	$t_F=0.1312$ s	$t_H=0.1542$ s	$t_B=0.0956$ s	$t_D=0.1081$ s
Overshoot	15.95%	15.33%	0.96%	1.94%

computation effort for the system under study. Nevertheless, it is interesting to study which is the maximum latency that can be reached in simulations before any stability issue appears, by considering that the two laboratories performing R-PHIL tests may be located at larger distances or connected by a less efficient (or more congested) network.

The same R-PHIL simulations presented in the previous section were repeated several times introducing an additional delay in the communication blocks. This extra delay was progressively increased starting from 50% to 800% the average delay of 12.5 ms (it corresponds respectively to an extra delay of 6.25 ms and 100 ms, each way). In all these tests, not shown here for the sake of brevity, the R-PHIL simulation proved to be stable. As shown in Fig. 12, that represents the voltage response registered in Bari during an upward load step variation adopting a 100 ms additional delay, excessive delays unavoidably affect the quality of the voltage response, which is not only delayed but also characterized by an anomalous transient behaviour, different from the one registered in the L-PHIL simulation (see, for example, the little bump in the voltage curve at about $t = 0.5$ s). However, the steady-state value can be considered conservatively reached before $t = 1$ s even in this extreme case.

Further tests were run by modifying the scaling factor in the R-PHIL simulation. This scale factor permits to vary

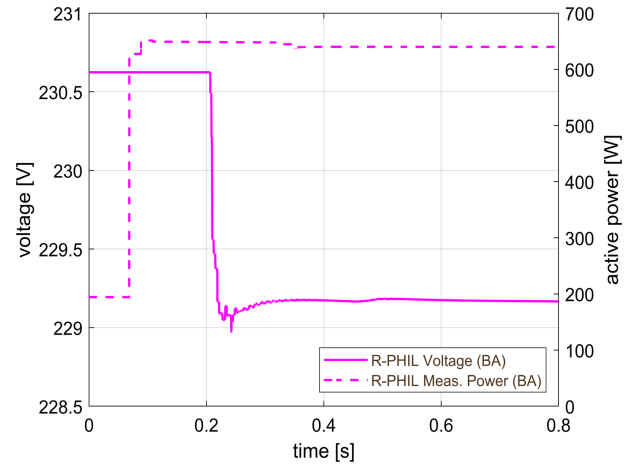

Fig. 12. Voltage and active power trajectories recorded at PoliBa for an upward load step variation: R-PHIL test with $\times 100$ scaling factor and 100 ms additional delay

the voltage deviation caused on the simulated grid by the hardware load step-change. The rationale behind these tests is given by the observation that if the scale factor is not too high (for example $\times 100$ as in all previous cases), the two co-simulations can be considered fully decoupled. Any delay in the P, Q response of Bari is seen as a small load disturbance in Turin, and vice versa for the V, f response. According to the previously mentioned tests (plus other tests where unrealistically large delays were assumed), even in the presence of extreme delays, the R-PHIL simulation remains stable. For this reason, the dependency between power and voltages was progressively increased by increasing the scale factor.

Fig. 13 collects the results of the R-PHIL tests obtained applying a $\times 1,400$ scaling factor. The upward and downward step variations were obtained adopting the same settings of the adjustable R-L load bank used in the previous tests. The steady state voltages reached after the upward and downward steps are respectively 203.27 V and 223.71 V, corresponding to a 0.086 p.u. voltage magnitude variation on the secondary distribution bus that interconnects the two co-simulated systems. The increased interaction between load and voltages, generates larger oscillations that can be considered damped out only around $t = 0.5$ s (dark blue plot). The introduction of additional communication delay worsens the R-PHIL simulation performances, with voltage oscillations that are less and less damped when latency increases. For the highest value of additional delay (100 ms), the R-PHIL test shows an unstable behavior as more clearly showed in Fig. 14. Please note that this behaviour cannot be shown for the PHIL system in Bari, because voltages applied to the microgrid are constrained through a saturation block in order to avoid damage to the hardware equipment.

Other tests were carried out further increasing the scaling factor. With a $\times 1,500$ scaling factor, simulations were stable with no additional delay, but with a small added delay (+6.25 ms) the simulation became rapidly unstable. This value represents the maximum limit of the scale factor, since

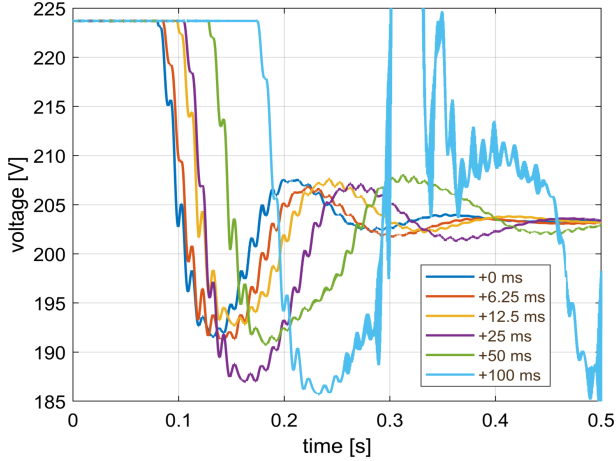

Fig. 13. Voltage trajectories simulated at PoliTo for an upward load step variation: R-PHIL tests with $\times 1,400$ scaling factor and varying additional communication delay

higher values, such as for example $\times 1,600$, showed unstable behaviour without any additional delay and also in the case of L-PHIL simulation (see Fig. 15).

Table III summarizes the results obtained by increasing the scaling factor. The results obtained with $\times 1,700$ and $\times 1,800$ are referred to software (SW) simulations only (no hardware in the loop). With a $\times 1,900$ no simulations are stable. In general, it should be noted that the highest scaling factors correspond to load step variations ΔS that are about 2 times the actual power installed on the secondary transformer ($S_n = 250$ kVA) and almost 40% of the maximum power that can be transferred, for this test case, before voltage stability limits are hit ($S_{max} = 1,230$ kVA). These simulations refer to system conditions far away from credible system states, but are still useful to give a measure of the stability performances.

All tests with credible scaling factors (much lower than $\times 1400$) showed stable R-PHIL performances. The R-PHIL system under study can simulate ordinary load fluctuations in the LV circuits and in the hardware equipment even in presence of delays largely higher the one reached by PoliBa and PoliTo (12.5 ms). When simulating extreme transient conditions, which could be briefly experienced for example during short-circuit simulations, R-PHIL and L-PHIL did not show significant difference in terms of stability.

IV. CONCLUSIONS

This work has shown how it is possible to share hardware resources among laboratories, resorting to the connection of real time simulators through a VPN, by performing a remote co-simulation with Power Hardware-in-the-Loop. Preliminary tests were performed to analyse the VPN performances. Thanks to these tests it was possible to choose the proper methodology and time step for exchanging electric variables in the co-simulation. **Using V , f and P , Q as exchanged electrical variables proved to be a good choice because it is a good compromise between simulation stability and fidelity, even in case of large communication delays.**

A real switchable R-L load was then used to build a remote PHIL (R-PHIL) co-simulation architecture, which was

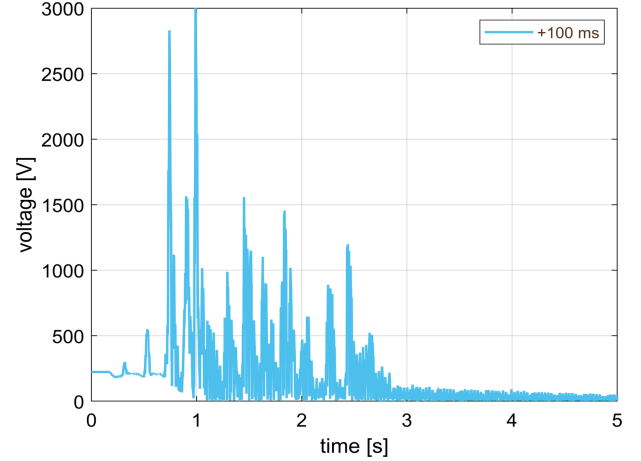

Fig. 14. Unstable voltage trajectory simulated at PoliTo for an upward load step variation: R-PHIL test with $\times 1,400$ scaling factor and 100 ms additional delay

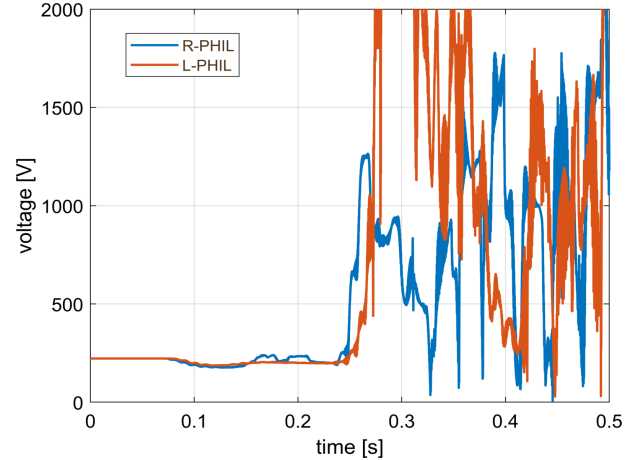

Fig. 15. Unstable voltage trajectories simulated at PoliTo (R-PHIL) and at PoliBa (L-PHIL) for an upward load step variation: R-PHIL and L-PHIL tests with $\times 1,600$ scaling factor and no additional delay

compared with the results of monolithic PHIL simulations, by analyzing the system responses to load step variations.

Although a perfect overlapping of the local and remote responses is not possible (due to the unavoidable communication delay and different experimental conditions), the accuracy of power and voltage is adequate to replicate remotely the real-time simulation performed locally, and the tested approach was proven to be feasible for the connection between two remote power system laboratories.

Further tests have been carried out in order to assess what is the impact of communication latency on the proposed co-simulation architecture and, in particular, which is the maximum latency that can be reached in simulations before any stability issue appears. Increased communication delays worsen the R-PHIL simulation performance, with increased voltage oscillations. This effect is amplified when high scaling factors are adopted for the hardware load in the simulated system. However, all tests with credible scaling factors showed a stable R-PHIL performance. The R-PHIL system under study can therefore simulate ordinary load fluctuations in the LV

TABLE III
ASSESSMENT OF SIMULATION STABILITY

Scale factor	V_{max} [V]	V_{min} [V]	$\Delta V/V_n$ [%]	ΔS [kVA]	$\Delta S/S_n$ [%]	$\Delta S/S_{max}$ [%]	max latency [ms]	stable simulations
100	230.7	229.4	0.59	46.6	18.6	3.6	no limit	R-PHIL, L-PHIL, SW
1,400	223.7	203.3	8.89	481.6	192.6	37.0	12.5+100	R-PHIL, L-PHIL, SW
1,500	223.2	201.3	9.51	504.0	201.6	38.8	12.5+6.25	R-PHIL, L-PHIL, SW
1,600	222.7	200.6	9.61	522.5	209.0	40.2	-	SW
1,700	222.2	198.7	10.22	541.7	216.7	41.7	-	SW
1,800	221.6	196.9	10.74	559.7	223.9	43.1	-	none

circuits and in the hardware equipment, even in presence of delays (and therefore geographical distances) largely higher than the one reached in the interconnection between PoliBa and PoliTo.

REFERENCES

- [1] Schet, "Roadmap to the Supergrid Technologies," http://www.friendsofthesupergrid.eu/Position_Papers_Proposals.aspx, no. March, pp. 1–107, 2012. [Online]. Available: http://www.friendsofthesupergrid.eu/position_papers_proposals.aspx
- [2] P. Singh, D. P. Kothari, and M. Singh, "Integration of distributed energy resources," *Research Journal of Applied Sciences, Engineering and Technology*, vol. 7, no. 1, pp. 91–96, 2014.
- [3] C.-F. Covrig, G. De Santi, G. Fulli, M. Masera, M. Olariaga-Guardiola, E. Bompard, G. Chicco, A. Estebarsari, T. Huang, E. Pons, F. Profumo, A. Tenconi, R. De Doncker, M. Grigull, A. Monti, M. Stevic, and S. Vogel, *An European Platform for Distributed Real Time Modelling & Simulation of Emerging Electricity Systems*, 2016. [Online]. Available: <http://publications.jrc.ec.europa.eu/repository/bitstream/JRC101772/replatform-2016.pdf>
- [4] M. Stevic, S. Vogel, M. Grigull, A. Monti, A. Estebarsari, E. Pons, T. Huang, and E. Bompard, "Virtual integration of laboratories over long distance for real-time co-simulation of power systems," *IECON Proceedings (Industrial Electronics Conference)*, pp. 6717–6721, 2016.
- [5] M. H. Syed, E. Guillo-Sansano, Y. Wang, S. Vogel, P. Palensky, G. M. Burt, Y. Xu, A. Monti, and R. Hovsopian, "Real-time coupling of geographically distributed research infrastructures: Taxonomy, overview and real-world smart grid applications," *IEEE Transactions on Smart Grids*, In Press.
- [6] E. Bompard, A. Monti, A. Tenconi, A. Estebarsari, T. Huang, E. Pons, M. Stevic, S. Vaschetto, and S. Vogel, "A multi-site real-time co-simulation platform for the testing of control strategies of distributed storage and V2G in distribution networks," *2016 18th European Conference on Power Electronics and Applications, EPE 2016 ECCE Europe*, 2016.
- [7] H. P. Figueroa, J. L. Bastos, A. Monti, and R. Dougal, "A modular real-time simulation platform based on the virtual test bed," in *2006 IEEE International Symposium on Industrial Electronics*, vol. 2, 2006, pp. 1537–1541.
- [8] M. O. Faruque, V. Dinavahi, M. Sloderbeck, and M. Steurer, "Geographically distributed thermo-electric co-simulation of all-electric ship," in *2009 IEEE Electric Ship Technologies Symposium*, 2009, pp. 36–43.
- [9] M. O. Faruque, M. Sloderbeck, M. Steurer, and V. Dinavahi, "Thermo-electric co-simulation on geographically distributed real-time simulators," in *2009 IEEE Power Energy Society General Meeting*, 2009, pp. 1–7.
- [10] ERIC-LAB, "ERIC-LAB." [Online]. Available: <https://www.eric-lab.eu/drupal/>
- [11] A. Monti, M. Stevic, S. Vogel, R. W. De Doncker, E. Bompard, A. Estebarsari, F. Profumo, R. Hovsopian, M. Mohanpurkar, J. D. Flicker, V. Gevorgian, S. Suryanarayanan, A. K. Srivastava, and A. Benigni, "A Global Real-Time Superlab: Enabling High Penetration of Power Electronics in the Electric Grid," *IEEE Power Electronics Magazine*, vol. 5, no. 3, pp. 35–44, 2018.
- [12] B. Lundstrom, B. Palmintier, D. Rowe, J. Ward, and T. Moore, "Trans-oceanic remote power hardware-in-the-loop: Multi-site hardware, integrated controller, and electric network co-simulation," *IET Generation, Transmission and Distribution*, vol. 11, no. 18, pp. 4688–4701, 2017.
- [13] L. Barbierato, A. Estebarsari, L. Bottaccioli, E. Macii, and E. Patti, "A distributed multimodel cosimulation platform to assess general purpose services in smart grids," *IEEE Transactions on Industry Applications*, vol. 56, no. 5, pp. 5613–5624, 2020.
- [14] V. H. Nguyen, T. L. Nguyen, Q. T. Tran, Y. Besanger, and R. Caire, "Integration of scada services and power-hardware-in-the-loop technique in cross-infrastructure holistic tests of cyber-physical energy systems," *IEEE Transactions on Industry Applications*, vol. 56, no. 6, pp. 7099–7108, 2020.
- [15] E. Bompard, S. Bruno, A. Cordoba-Pacheco, C. Diaz-Londono, G. Giannoccaro, M. La Scala, A. Mazza, and E. Pons, "Connecting in real-time power system labs: an italian test-case," in *2020 IEEE International Conference on Environment and Electrical Engineering and 2020 IEEE Industrial and Commercial Power Systems Europe (EEEIC / I CPS Europe)*, 2020, pp. 1–6.
- [16] A. Mazza, A. Estebarsari, G. Morandi, E. Bompard, and H. Lok, "Remote hardware-in-the-loop measurement system for electrolyser characterization," in *EEEIC 2019, IEEE*, Ed., 2019, p. 6.
- [17] A. Valibeygi, R. A. de Callafon, M. Stanovich, M. S. K. Schoder, J. L. I. Leonard, S. Chatterjee, and R. Meeker, "Microgrid control using remote controller hardware-in-the-loop over the internet," in *2018 IEEE Power Energy Society Innovative Smart Grid Technologies Conference (ISGT)*, 2018.
- [18] R. Liu, M. Mohanpurkar, M. Panwar, R. Hovsopian, A. Srivastava, and S. Suryanarayanan, "Geographically distributed real-time digital simulations using linear prediction," *International Journal of Electrical Power & Energy Systems*, vol. 84, pp. 308 – 317, 2017.
- [19] L. Pellegrino, C. Sandroni, E. Bionda, D. Pala, D. T. Lagos, N. Hatziaargyriou, and N. Akroud, "Remote laboratory testing demonstration," *Energies*, vol. 13, no. 9, p. 2283, May 2020.
- [20] Erigridd, "ERIGrid 2.0: Connecting European Smart Grid Infrastructure." [Online]. Available: <https://erigridd2.eu/>
- [21] T. I. Strasser, E. C. W. de Jong, and M. Sosnina, Eds., *European Guide to Power System Testing*. Springer Open, 2020.
- [22] E. Bompard, S. Bruno, S. Frittoli, G. Giannoccaro, M. L. Scala, A. Mazza, E. Pons, and C. Rodio, "Remote PHIL Distributed Co-Simulation Lab for TSO-DSO-Customer Coordination Studies," in *2020 AEIT International Annual Conference (AEIT)*, 2020, pp. 1–6.
- [23] S. Bruno, G. Giannoccaro, M. L. Scala, and G. Lopopolo, "First activities and power-hardware-in-the-loop tests at the public research laboratory LabZERO," *2018 110th AEIT International Annual Conference, AEIT 2018*, 2018.
- [24] G. De Carne, S. Bruno, M. Liserre, and M. La Scala, "Distributed Online Load Sensitivity Identification by Smart Transformer and Industrial Metering," *IEEE Transactions on Industry Applications*, vol. 55, no. 6, pp. 7328–7337, 2019.
- [25] B. Palmintier, B. Lundstrom, S. Chakraborty, T. Williams, K. Schneider, and D. Chassin, "A Power Hardware-in-the-Loop Platform with Remote Distribution Circuit Cosimulation," *IEEE Transactions on Industrial Electronics*, vol. 62, no. 4, pp. 2236–2245, 2015.
- [26] T. Hatakeyama, A. Riccobono, and A. Monti, "Stability and accuracy analysis of power hardware in the loop system with different interface algorithms," in *2016 IEEE 17th Workshop on Control and Modeling for Power Electronics (COMPEL)*. IEEE, 2016, pp. 1–8.
- [27] M. Hong, Y. Miura, T. Ise, Y. Sato, T. Momose, and C. Dufour, "Stability and accuracy analysis of power hardware-in-the-loop simulation of inductor coupled systems," *IEEE Transactions on Industry Applications*, vol. 130, no. 7, pp. 902–912, 2010.
- [28] S. Bruno, G. Giannoccaro, C. Iurlaro, M. L. Scala, and C. Rodio, "A low-cost controller to enable synthetic inertia response of distributed energy resources," in *2020 IEEE International Conference on Environment and Electrical Engineering and 2020 IEEE Industrial*

- and Commercial Power Systems Europe (EEEIC / I CPS Europe)*, 2020, pp. 1–6.
- [29] S. Vogel, V. S. Rajkumar, H. T. Nguyen, M. Stevic, R. Bhandia, K. Heussen, P. Palensky, and A. Monti, “Improvements to the Co-simulation Interface for Geographically Distributed Real-time Simulation,” *IECON Proceedings (Industrial Electronics Conference)*, vol. 2019-October, pp. 6655–6662, 2019.
- [30] C. Diaz-Londono, G. Fambri, A. Mazza, M. Badami, and E. Bompard, “A real-time based platform for integrating power-to-gas in electrical distribution grids,” in *2020 55th International Universities Power Engineering Conference (UPEC)*, 2020, pp. 1–6.