

Global-local plug-in for high-fidelity composite stress analysis in ABAQUS

*Original*

Global-local plug-in for high-fidelity composite stress analysis in ABAQUS / Carrera, E.; de Miguel, A. G.; Filippi, M.; Kaleel, I.; Pagani, A.; Petrolo, M.; Zappino, E.. - In: MECHANICS OF ADVANCED MATERIALS AND STRUCTURES. - ISSN 1537-6494. - ELETTRONICO. - 28:14(2021), pp. 1445-1450. [10.1080/15376494.2019.1676938]

*Availability:*

This version is available at: 11583/2909000 since: 2021-06-23T14:30:46Z

*Publisher:*

Taylor & Francis

*Published*

DOI:10.1080/15376494.2019.1676938

*Terms of use:*

This article is made available under terms and conditions as specified in the corresponding bibliographic description in the repository

*Publisher copyright*

Taylor and Francis postprint/Author's Accepted Manuscript

This is an Accepted Manuscript of an article published by Taylor & Francis in MECHANICS OF ADVANCED MATERIALS AND STRUCTURES on 2021, available at <http://www.tandfonline.com/10.1080/15376494.2019.1676938>

(Article begins on next page)

# Global-local plug-in for high-fidelity composite stress analysis in ABAQUS

E. Carrera,\* A.G. de Miguel †, M. Filippi ‡, I. Kaleel§, A. Pagani,¶ M. Petrolo,|| and E. Zappino\*\*

MUL<sup>2</sup> Group, Department of Mechanical and Aerospace Engineering, Politecnico di Torino  
Turin, Italy

Submitted to Mechanics of Advanced Materials and Structures

*Author for correspondence:*

Erasmus Carrera, Professor

MUL<sup>2</sup> Group, Department of Mechanical and Aerospace Engineering,  
Politecnico di Torino,

Corso Duca degli Abruzzi 24,

10129 Torino, Italy,

tel: +39 011 090 6836,

fax: +39 011 090 6899,

e-mail: erasmo.carrera@polito.it

---

\*Professor of Aerospace Structures and Aeroelasticity, erasmo.carrera@polito.it

†Postdoctoral researcher, alberto.garcia@polito.it

‡Assistant Professor, matteo.filippi@polito.it

§Postdoctoral researcher, ibrahim.kaleel@polito.it

¶Assistant Professor, alfonso.pagani@polito.it

||Assistant Professor, marco.petrolo@polito.it

\*\*Assistant Professor, enrico.zappino@polito.it

## ***Abstract***

*This paper introduces a user-friendly tool for accurate stress prediction in laminate shell models in ABAQUS. The aim is to provide users with a code for the fast computation of three-dimensional solutions that overcome the limitations of classical shell models and facilitate the use of advanced composite failure criteria consistently. The methodology is based on a two-step global/local technique, denoted to as element-wise (EW), in which accurate local models with 3D capabilities stem from individual shell elements. The local analysis exploits refined laminated theories accounting for layer-wise deformations. Numerical examples on a typical aircraft structure serve as assessments to show the tool capabilities in handling various failure mode onsets., e.g., fiber breakage and matrix cracking.*

**Keywords:** Global-local analysis, Stress analysis, Failure index evaluation, ABAQUS, Laminates, Carrera Unified Formulation

# 1 Introduction

Laminated composite structures are increasing their share in industrial applications for the production of components with superior characteristics as compared to metallic counterparts. During the last years, the implementation of advanced manufacturing techniques for composite structures has enabled the introduction of new lightweight structural solutions. At the same time, the enhancement of computational capabilities and theoretical knowledge is allowing engineers to accelerate and optimize the design and production process through the use of advanced simulation tools. One of such tools relies on high-fidelity structural models for composite materials to predict the response and failure modes of the components accurately.

The prediction of the failure limits of a structure requires a good evaluation of strains and stresses. The most adopted technique in the industry to achieve this goal is the finite element method (FEM), allowing to handle complex geometries and boundary conditions. 2D formulations are common choices for the analysis of shell-like reinforced structures as they simplify the problem by assuming the deformations over the thickness. Among them, the most used theory for composite analysis is the first-order shear deformation theory (FSDT) based on the Reissner [1] - Mindlin [2] kinematics. Most of the commercial FEM software, such as ABAQUS [3], make use of FSDT elements to compute stress fields in laminated structures with acceptable computational efforts. However, one must be aware that FSDT is not sufficient to predict the interlaminar stresses across the stack of plies, although can cause structural failures. To this purpose, the scientific community has produced many different structural theories to predict the 3D stress fields in laminates. A comprehensive review of these refined models is in Kapania and Raciti [4, 5] or Carrera [6].

The inclusion of these advanced theories into commercial codes is not straightforward, and 3D elements remain as the main option for 3D stress fields. Primary obstacles for the transition to advanced theories in industrial environments are their complexity in terms of mathematical assumptions and input/output management.

A method that mitigates such difficulties relies on global/local approaches. Global/local methods can calculate the 3D mechanical response in the critical structural zones without incurring

unbearable computational overheads and pre- and post-processing complexities. In essence, this approach tunes the level of detail of a numerical model in certain parts of the structure according to the desired accuracy. Well-known examples of global/local approaches are the mesh refinements [7], the superelements [8] and multi-step methods [9, 10, 11]. The last set decouples the analysis into a global 'coarse' model and a local 'refined' model. The coupling of the two models makes use of specific boundary conditions at the interfaces. The effective application of global/local methods may require a high level of familiarity with stress analysis methods and may lead to a considerable amount of time and resources. For this reason, its use in the preliminary phases of the design and optimization of the composite structure layout is not standard.

The present work aims at tackling this issue by introducing a user-friendly plug-in for the computation of 3D stresses in generic laminated structures using ABAQUS. The proposed approach merges the efficiency and accuracy of refined laminate theories for composite analyses and the scalability of global/local approaches. The tool has a graphical user interface (GUI) within ABAQUS, leading to 3D results across the stack of plies directly from the same display. Making use of the element-wise (EW) approach, previously introduced by the authors for other FEM software [12], the user needs to select the shell elements in which the 3D solutions are of interest. The code automatically manages all the inputs and boundary conditions for the local solver that in the plug-in package referred to as MUL2@GL.

This paper is organized as follows: Section 2 provides the basic theoretical background, including the selected structural theories and the global/local approach. Then, the GUI for ABAQUS is presented in Section 3 describing how to install and launch the tool. Section 4 shows the numerical assessments on a full section of a composite wing. Finally, the conclusions are in Section 5.

## **2 Element-wise approach**

The assessment of the failure onset typically requires mathematical criteria accounting for the margin between the actual stresses in all points of the structure and the maximum allowable

of the material. In metals, the distribution of the stresses over the structure is somewhat more straightforward than in composites. Complicating effects in composites stem from their anisotropy and shear deformability. Moreover, the majority of the mathematical models for the evaluation of failure in composites include the effects of the transverse shear and normal stresses [13] to account for matrix failure, kinking or delamination modes, among others.

## 2.1 Structural theories

The element kinematics for based on FSDT is as follows

$$u_x(x, y, z) = N_i(x, y) u_{x_0} + z N_i(x, y) \phi_y, \quad (1)$$

$$u_y(x, y, z) = N_i(x, y) u_{y_0} - z N_i(x, y) \phi_x, \quad i = 1, \dots, n \quad (2)$$

$$u_z(x, y, z) = N_i(x, y) u_{z_0} \quad (3)$$

being  $n$  the number of nodes of the element and  $N_i$  the shape functions. The 2D elements based on this model have five unknowns, or degrees of freedom (DOF), namely, three displacements and two rotations. The expected deformation of the element exhibits a linear dependency in the thickness direction. As a consequence, the distribution of the transverse stress fields in FSDT elements results to be rather poor. Moreover, as well-known, the assumptions of Eqs. 1, 2 and 3 only hold for thin laminates, and they fail to represent the through-the-thickness behavior in critical areas such as holes, free-edges, and corners. Various solutions exist to extend the applicability of 2D formulations. For instance, ABAQUS has a continuum shell in its 2D element library based on a first-order layer-wise (LW) theory [14] for better transverse predictions in bending-dominated problems. For the evaluation of refined through-the-thickness responses, they recommend the stacking of multiple elements [3]. The present work aims to complement the laminate analysis in ABAQUS with refined composite modeling to provide 3D fields across the thickness. The approach uses a global/local method in which the single 2D elements are selectable as local models for a second step stress analysis, see Fig. 1. The structural model of the local zone adopts the Carrera

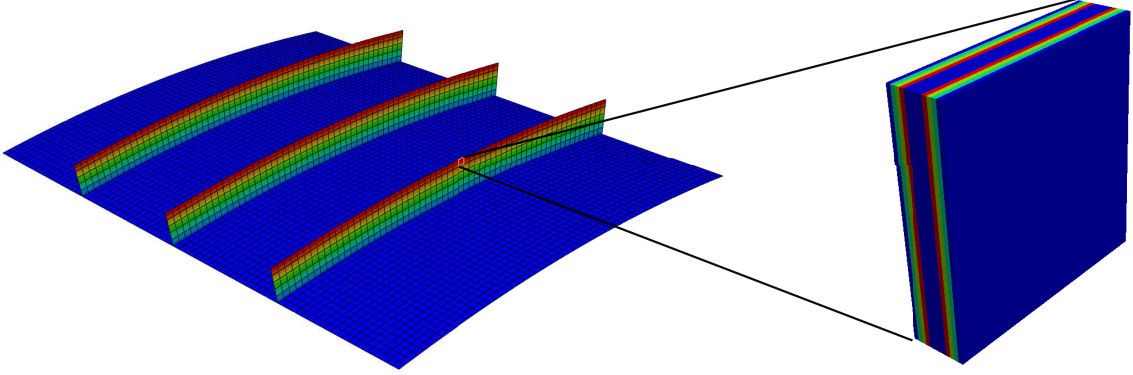

Figure 1: Global-local analysis based on the EW approach.

Unified Formulation (CUF) [6], an established methodology to generate any mathematical theories for multi-layered structures. Based on CUF, the LW kinematic expansion of the plate element is

$$\mathbf{u}^k(x, y, z) = N_i(x, y) F_\tau^k(z) \mathbf{u}_\tau^k \quad \text{for } \tau = 1, \dots, M \quad (4)$$

where  $k$  indicates the  $k$ -th layer,  $F_\tau$  are functions of the thickness coordinate, and  $M$  is the number of these functions. In this work, the results stem from a third-order  $F_\tau$  as this order is sufficiently high to provide a good approximation of the 3D stresses.

## 2.2 Global/local approach

The coupling implemented in this work is one-way with the compatibility of the displacement fields between the original 2D global FEM, and the enriched LW local model stems from the imposition of boundary conditions in the latter. For a four-node element (S4 or S4R in ABAQUS), the displacements and rotations of the nodes are interpolated over the local mesh to model a continuous transition of the solution from the global to local models, see Figure 2. As it is well-described in the literature, this approach generates a transition zone in the local model in which the stress solutions could be unreliable [15]. However, this fact does not raise any issue since this tool aims to compute the 3D fields at the centroid of the element, as an extension of the stress outputs of the global FEM results. The main advantage of the EW approach is that the

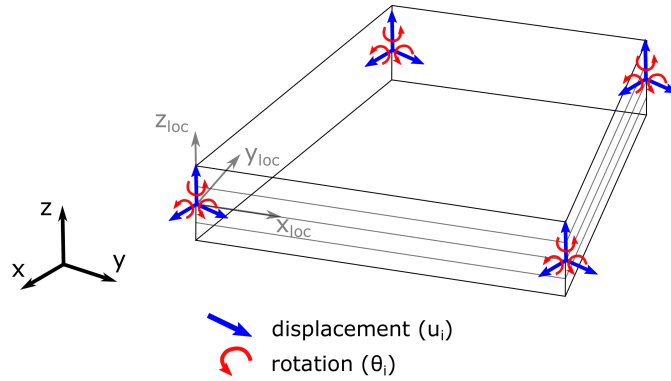

Figure 2: Sets of coordinate systems and boundary conditions adopted in the EW approach.

global/local process is simple from the user perspective. Indeed, all the information to generate the local model - geometry, material, and boundary conditions - originate from the bulk data file of ABAQUS (.odb) with no need for a further modeling effort. Moreover, the user can select the critical elements of the structure; for instance, those showing the highest failure indexes, and obtain a more refined set of solutions to confront the results. The low work demand of the EW may be of interest at all phases of the design, including the preliminary ones leading to reductions in the number of iterations between the design and the structural analysis.

### 3 Abaqus plug-in and GUI

The model is in the software package MUL2@GL via an ABAQUS plug-in, see Fig. 3. The script is in Python as supported by the ABAQUS environment and leading to a straightforward passage of information between the FEM and MUL2@GL. The installation of MUL2@GL in ABAQUS is the same as for any other plug-in [16]. A GUI enables a user-friendly experience. From the MUL2@GL window, the critical elements are selected in the current output file on display. After the fast computations of the local 3D fields, the tool presents the plots of the 3D strain and stress solutions - all six components - and failure criteria on the screen. It also saves the data in DAT and CSV format for Excel. This process is repeatable as many times as wanted, based on the number of critical elements considered. The availability of such refined solutions may allow structural engineers to calculate the desired failure criteria consistently, using the right strain/stress inputs.

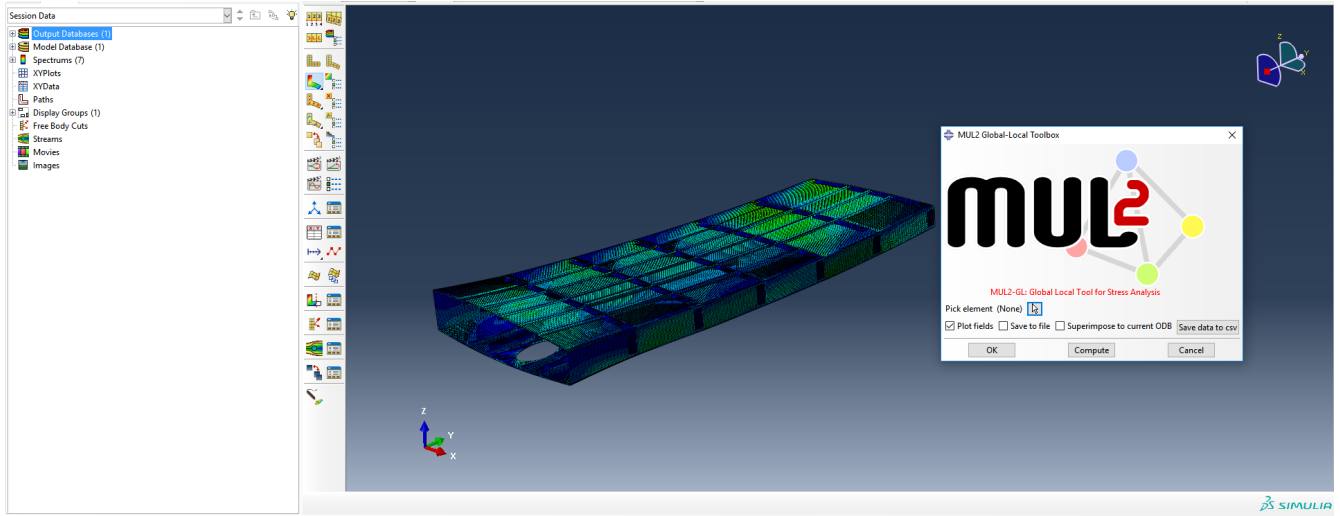

Figure 3: MUL2@GL plugin interface for ABAQUS.

## 4 Numerical results

The static analysis of a benchmark composite wing-box aims to prove the capability of the MUL2@GL plug-in to evaluate stress fields and failure indices. The composite wing-box consists of an assembly of skins, stringers, ribs, and spars with layup configurations ranging from 32 to 64 plies in various locations across the structure. The mesh uses linear shell elements (S4R) within ABAQUS [3]. As in Fig.4a, the nodes along the root section are clamped and several loadings applied across the wing-box accounting for aerodynamic forces, fuel loads and the structural weight. The deformed configuration of the wing-box is in Fig. 4b. An element on the lower skins which exhibited maximum the Tsai-Wu index is the one chosen for the global-local analysis. Figures 5 and 6 show the in-plane and out-of-plane stress fields through the thickness at the center of the selected element, respectively. The stress fields are in the ply coordinate system with 1 - parallel to fiber, 2 - normal to the fiber, and 3 - thickness direction. It is evident from Fig. 5 that the in-plane stress fields obtained using the global and local analyses agree well. All the stress components stemmed from the use of the constitutive law. The out-of-plane components are those from the local model only as the global ones, based on FSDT, would require recovery techniques. The failure index evaluations use four failure criteria. (a) Tsai-Wu (2D and 3D) [17], (b) Hoffman [18], (c) Hashin [19], and (d) LARC05 [20]. Figure 7 shows the comparison of Hoffman and Tsai-Wu

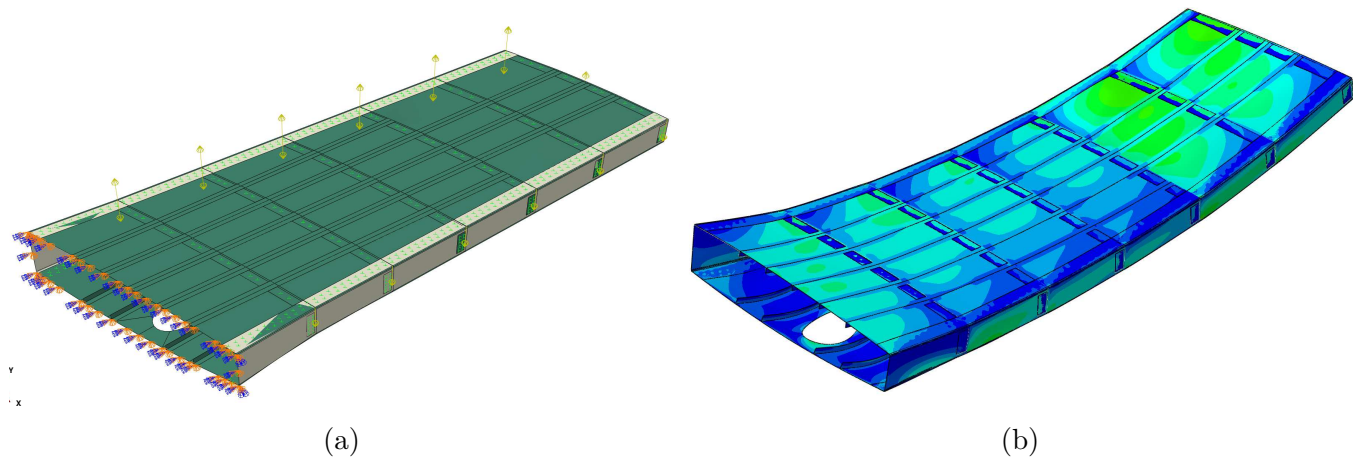

Figure 4: Benchmark composite wing-box: (a) geometry and boundary conditions and (b) deformed configuration.

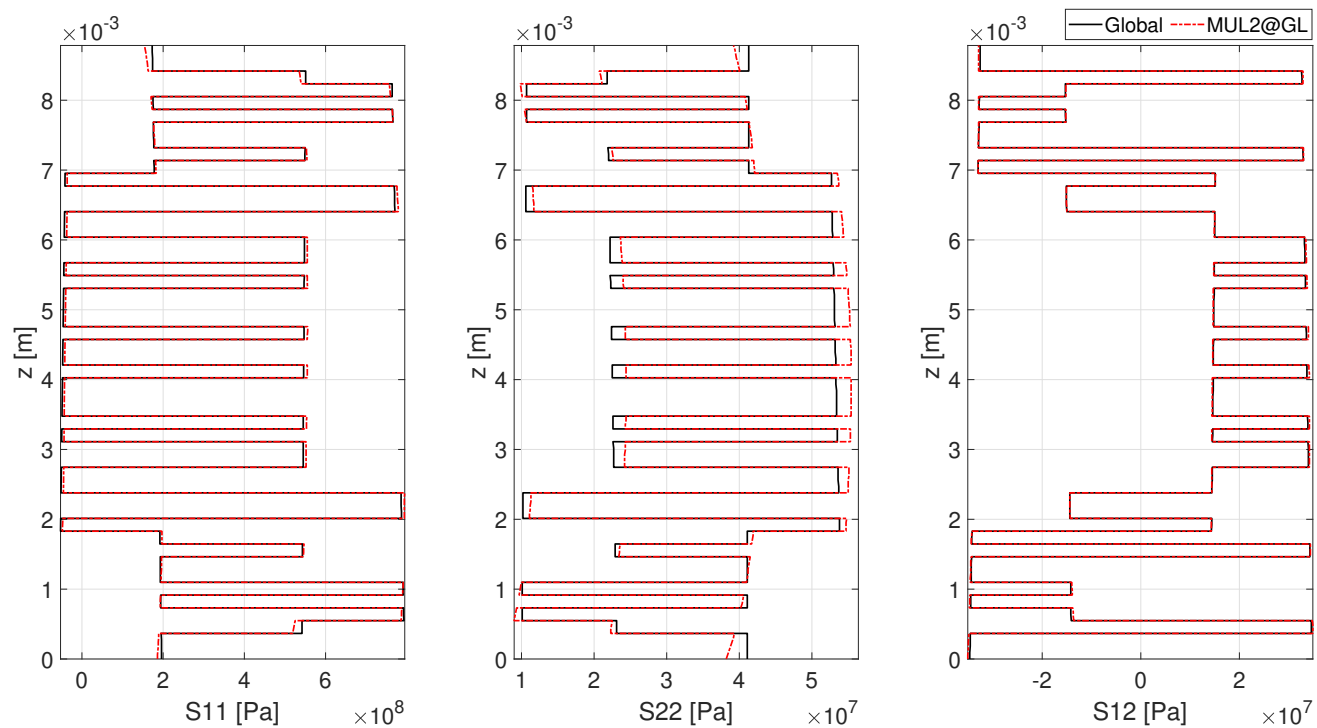

Figure 5: Comparison of through-the-thickness, in-plane stress fields at the center of the selected element obtained through global and local analyses.

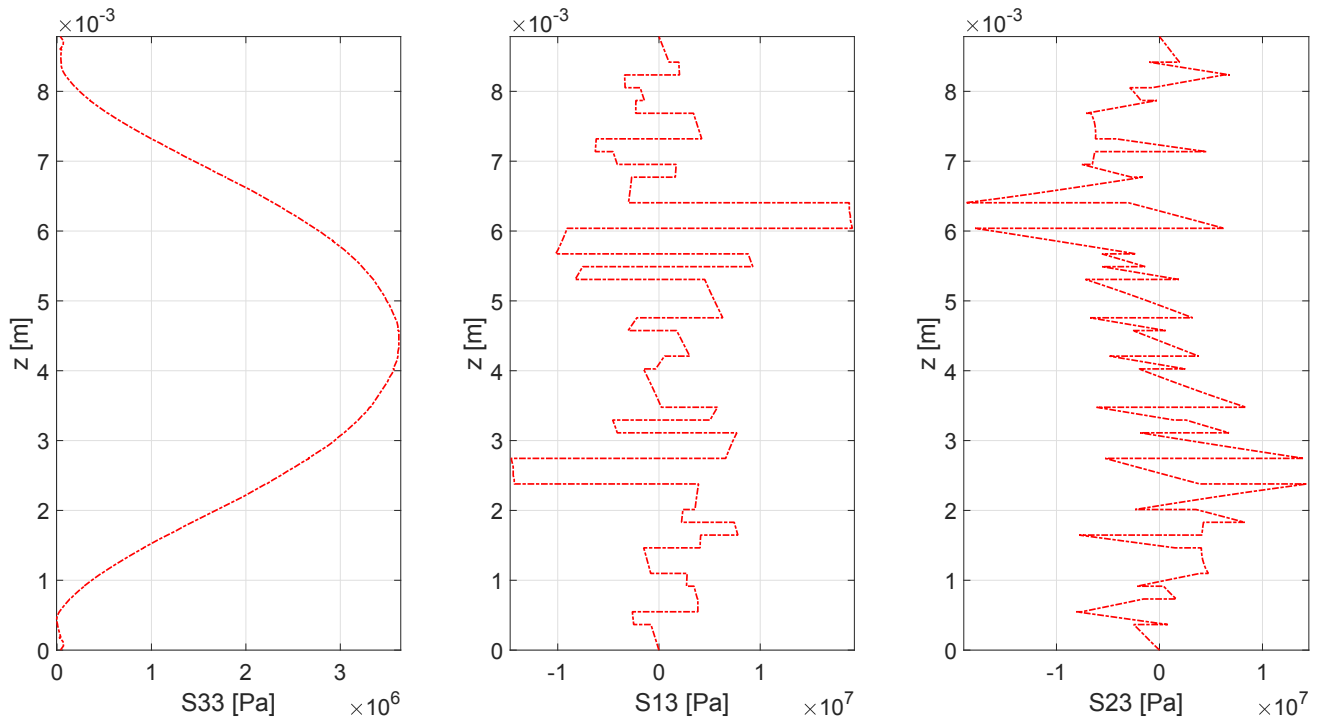

Figure 6: Through-the-thickness, out-of-plane stress fields at the center of the selected element.

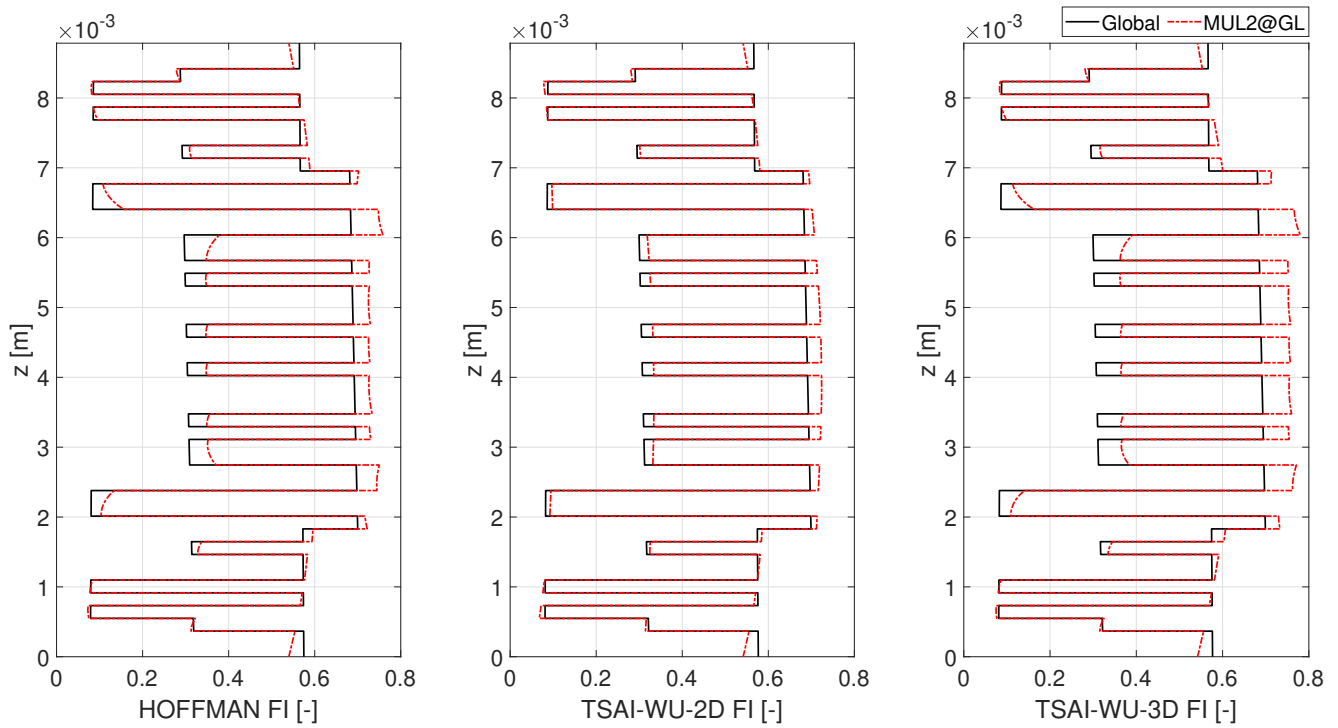

Figure 7: Comparison of Hoffman and Tsai-Wu (2D and 3D) failure indices at the center of the selected element of the lower skin obtained through global and local analyses.

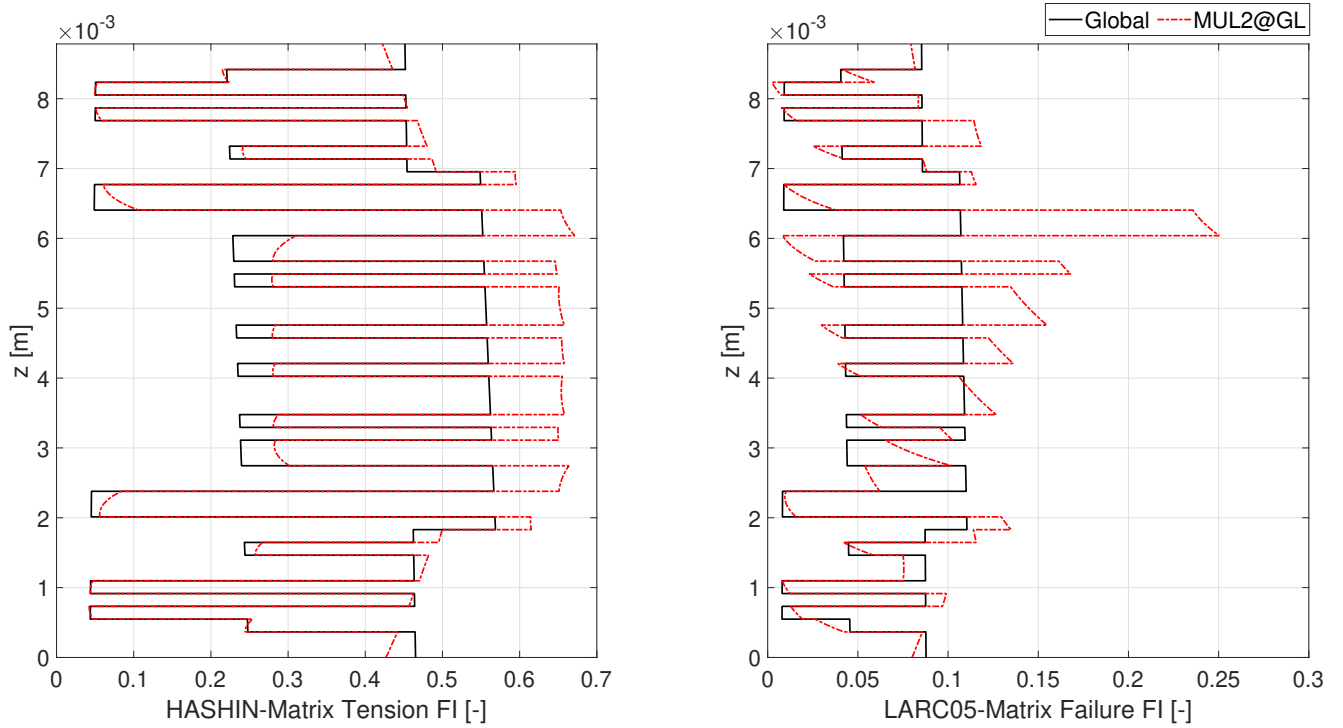

Figure 8: Comparison of Hashin Matrix Tension and LARC05 Matrix failure indices at the center of the selected element of the lower skin obtained through global and local analyses.

(2D and 3D) failure indices for global and local analysis. The comparison of Hashin and LARC05 failure indices are in Fig. 8. Table 1 presents the maximum failure indices obtained using various criteria for the global and local analyses along with the percentage difference between them. The results suggest that

1. The out-of-plane stress fields, especially  $\sigma_{13}$  and  $\sigma_{23}$ , are of the same orders of magnitude as the in-plane stress fields.
2. As the global analysis can capture the in-plane stress accurately, failure indices as the Tsai-Wu 2D and Hoffman compare well with local solutions. These failure indices use in-plane stress fields only.
3. The Tsai-Wu 3D, accounting for all the stress components, show larger differences than the previous ones with underestimations in the global analysis.
4. Differences become very significant in the case of advanced failure indices such as Hashin

and LARC05 in which the full 3D resolution of stress fields is paramount.

Table 1: Maximum indices for various failure criteria obtained using global-local analysis.

Failure Index	Global	Local	Difference (%)
Tsai-Wu 2D	0.70	0.72	2.77
Tsai-Wu 3D	0.70	0.78	10.25
Hoffman	0.70	0.76	7.89
Hashin - Matrix Tension	0.57	0.67	14.92
LARC05 - Matrix failure	0.11	0.25	126.57

## 5 Conclusion

This paper presents the development of a user-friendly tool for the 3D stress prediction in shell elements of ABAQUS. The tool is installable as a plug-in and allows the user to complement the preliminary stress analysis with highly refined through-the-thickness solutions. The proposed approach exploits a global/local method with one-way coupling. The local zone can be a single shell element of the global FEM model. This method, referred to as element-wise (EW), enables a straightforward and quick global/local analysis as all the required information is extractable automatically from the ABAQUS data files. The local model has refined layer-wise (LW) kinematics, leading to the accurate prediction of the out-of-plane components.

The MUL2@GL may fill the gap between the preliminary structural analyses which are typically used for design and optimization purposes, and the detailed failure evaluation of the critical zones of the structure. Besides, it can enhance the preliminary and optimization analyses by providing accurate failure estimations with computational costs comparable to those of numerical models adopted in the first phases of the development.

## Acknowledgments

This research work has been carried out within the project FULLCOMP (Fully Integrated Analysis, Design, Manufacturing, and Health-Monitoring of Composite Structures), funded by the European

Union Horizon 2020 Research and Innovation program under the Marie Skłodowska-Curie Grant agreement No. 642121.

## References

- [1] E. Reissner. The effect of transverse shear deformation on the bending of elastic plates. *Journal of Applied Mechanics*, 12(2):69–77, 1945.
- [2] R.D. Mindlin. Influence of rotary inertia and shear flexural motion of isotropic, elastic plates. *Journal of Applied Mechanics*, 18:31–38, 1951.
- [3] ABAQUS. *Abaqus Analysis User's Guide*. Dassault Systèmes, 2014.
- [4] R.K. Kapania and S. Raciti. Recent advances in analysis of laminated beams and plates, part I: Shear effects and buckling. *AIAA Journal*, 27(7):923–935, 1989.
- [5] R.K. Kapania and S. Raciti. Recent advances in analysis of laminated beams and plates, part II: Vibrations and wave propagation. *AIAA Journal*, 27(7):935–946, 1989.
- [6] E. Carrera. Theories and finite elements for multilayered, anisotropic, composite plates and shells. *Archives of Computational methods in Engineering*, 9(2):87–140, 2002.
- [7] B. Szabó and I. Babůska. *Finite Element Analysis*. Wiley Interscience, New York, USA, 1991.
- [8] R. Guyan. Reduction of stiffness and mass matrices. *AIAA Journal*, 3:380 – 387, 1965.
- [9] J. Fish. The s-version of the finite element method. *Computers and Structures*, 43(3):539–547, 1992.
- [10] K.W. Shim, D.J. Monaghan, and C.G. Armstrong. Mixed dimensional coupling in finite element stress analysis. *Engineering with Computers*, 18:241–252, 2002.
- [11] K.M. Mao and C.T. Sun. A refined global-local finite element analysis method. *International Journal of Numerical Methods in Engineering*, 32:29–43, 1991.

- [12] E. Carrera, A.G. de Miguel, M. Filippi, I. Kaleel, A. Pagani, M. Petrolo, and E. Zappino. Global-local plug-in for high-fidelity composite stress analysis in Femap/NX Nastran. *Mechanics of Advanced Materials and Structures*, 2019.
- [13] A.C. Orifici, I. Herszberg, and R.S. Thomson. Review of methodologies for composite material modelling incorporating failure. *Composite Structures*, 86(1):194 – 210, 2008. Fourteenth International Conference on Composite Structures.
- [14] J.N. Reddy. On refined computational models of composite laminates. *International Journal for Numerical Methods in Engineering*, 27(2):361–382, 1989.
- [15] C.T. Sun and K.M. Mao. A global-local finite element method suitable for parallel computations. *Computers and Structures*, 29(2):309 – 315, 1988.
- [16] ABAQUS. *Abaqus/CAE User’s Guide*. Dassault Systèmes, 2014.
- [17] S.W. Tsai and E.M. Wu. A general theory of strength for anisotropic materials. *Journal of Composite Materials*, 5(1):58–80, 1971.
- [18] O. Hoffman. The brittle strength of orthotropic materials. *Journal of Composite Materials*, 1(2):200–206, 1967.
- [19] Z. Hashin. Failure criteria for unidirectional fiber composites. *Journal of applied mechanics*, 47(2):329–334, 1980.
- [20] S.T. Pinho, R. Darvizeh, P. Robinson, C. Schuecker, and P.P. Camanho. Material and structural response of polymer-matrix fibre-reinforced composites. *Journal of Composite Materials*, 46(19-20):2313–2341, 2012.