

On the real performance of groundwater heat pumps: Experimental evidence from a residential district

Original

On the real performance of groundwater heat pumps: Experimental evidence from a residential district / Biglia, Alessandro; Ferrara, Maria; Fabrizio, Enrico. - In: APPLIED THERMAL ENGINEERING. - ISSN 1359-4311. - STAMPA. - 192:(2021), p. 116887. [10.1016/j.applthermaleng.2021.116887]

Availability:

This version is available at: 11583/2898348 since: 2021-05-18T15:47:19Z

Publisher:

Elsevier

Published

DOI:10.1016/j.applthermaleng.2021.116887

Terms of use:

This article is made available under terms and conditions as specified in the corresponding bibliographic description in the repository

Publisher copyright

Elsevier postprint/Author's Accepted Manuscript

© 2021. This manuscript version is made available under the CC-BY-NC-ND 4.0 license
<http://creativecommons.org/licenses/by-nc-nd/4.0/>. The final authenticated version is available online at:
<http://dx.doi.org/10.1016/j.applthermaleng.2021.116887>

(Article begins on next page)

On the real performance of groundwater heat pumps: experimental evidence from a residential district

Alessandro Biglia ¹, Maria Ferrara ^{2,*}, Enrico Fabrizio ²

¹ Department of Agricultural, Forest and Food Sciences (DiSAFA) – Università degli Studi di Torino, Largo Paolo Braccini 2, 10095 Grugliasco (TO), Italy

² Department of Energy (DENERG) – Politecnico di Torino, Corso Duca degli Abruzzi 24, 10129 Torino, Italy

* Corresponding author: maria.ferrara@polito.it (M. Ferrara)

Abstract

Heat pumps are among the most promising technologies driving energy transitions towards the carbon reduction objectives. Their use is being particularly encouraged in the residential sector, where the heating and cooling uses account for the larger energy demand. However, their real performance often does not correspond to designers' expectations, leading to higher running energy costs than expected, and the reasons should be primarily investigated by means of large data collection and analysis.

This paper reports the results of a long-term monitoring campaign of a multipurpose groundwater heat pump system for a district of multifamily buildings in Italy. The survey includes data on thermal energy consumption for space heating, domestic hot water, space cooling and electricity consumption of the groundwater heat pumps taken between 2017 and 2018. It was shown that the performance of the installed groundwater heat pumps was significantly lower (up to 60%) than expected. Some defined strategies, mainly related to the system control logic, were demonstrated to be able to significantly increase the system performance, highlighting the need for improvements in integrated design and control strategies since the early design phase and for continuous monitoring in operation to optimise the system integration in real contexts.

Keywords: Multipurpose heat pumps, Total efficiency ratio, Multifamily building, Long-term energy monitoring, Heating and cooling, Building operation control

Nomenclature

n/a	not available
CA	conditioned area
COND	condenser
COP	coefficient of performance
CV	conditioned volume
DHW	domestic hot water
DSH	desuperheater
EER	energy efficiency ratio
EVAP	evaporator
HP	heat pump
HX	heat exchanger
OCA	occupied conditioned area
PeI	electric power
PRL	part load ratio
Q_c	space cooling load
Q_{dhw}	domestic hot water heating load
Q_h	space heating load
SC	space cooling
SCOP	seasonal coefficient of performance
SEER	seasonal energy efficiency ratio
SH	space heating
SPF	Seasonal performance factor
TER	total efficiency ratio

1. Introduction

The building sector consumes over one-third of all final energy and nearly half of the global electricity consumed [1], thus resulting responsible for approximately one-third of carbon dioxide (CO₂) emissions globally [2].

Since the population is expected to increase by 2.5 billion people in the next 30 years, the energy demand from the building sector will rise sharply driven by growth in the number of households, placing additional pressure on the energy system [3] and leading to the need for solutions able to face the rise of energy demand while reducing the related CO₂ emissions.

In Europe, in order to meet the European environmental targets, the CO₂ emission levels from cities need to be dramatically reduced and, considering that 75% of the entire European building stock is residential, the role of such sector in driving towards post-carbon cities is crucial [4].

The use of energy in residential buildings is mainly due to space heating (SH), space cooling (SC) preparation of domestic hot water (DHW), lighting and appliances [5]. According to the statistics of International Energy Agency [6], SH is the biggest energy use in this sector and it is recognised that a valuable possibility of turning cities into “smart cities” is renovating and retrofitting buildings with low emission heating systems [7][8]. In Italy, as shown in Fig. 1, SH, SC and DHW are estimated to account for more than 80% of final energy consumption in the residential sector. Therefore, major efforts to reduce energy consumption and CO₂ emissions in the residential sector should focus on reducing demand for such uses, increasing the efficiency of heating and cooling systems and maximising the use of renewables [9][10][11].

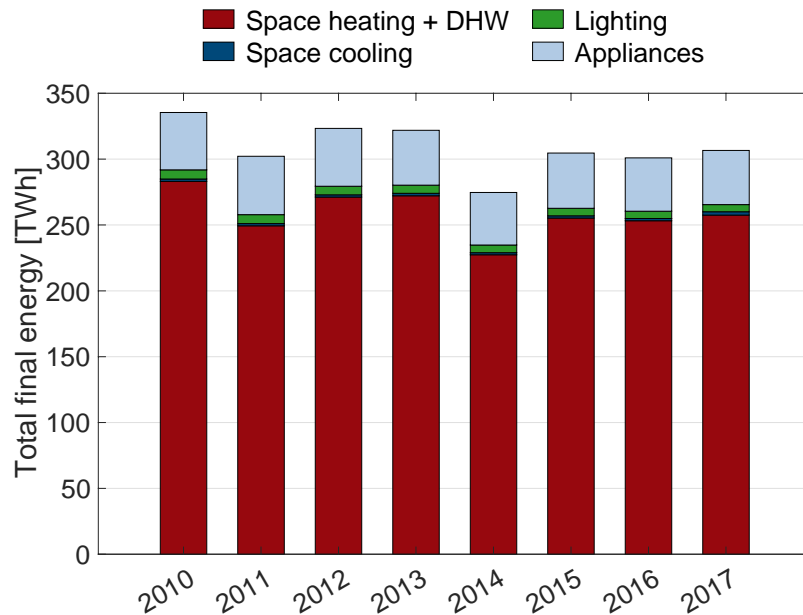

Figure 1. Energy use breakdown in the residential sector in Italy, 2000-2017 (source: IEA [6]).

Some of the technologies that may help in reducing building energy consumptions are already commercially available and cost-effective. Examples include heat pumps [12][13], photovoltaic systems [14][15], solar and hybrid solar-photovoltaic panels [16][17], cogeneration systems [18][19], high-performance windows [20][21], building insulation [22][23], energy efficient appliances and equipment [24][25][26] and efficient control [27][28]. It was also demonstrated that best performances are achieved when the mutual relationships between the different technologies are optimised [29][30].

Among the others, heat pumps may play a central role in driving the transition to the adoption of clean energy technologies, as also envisioned by IEA in its Energy Technology Perspectives studies [31], because of their high technology readiness level and the consequent possibility of large-scale implementation in the short term. This idea is also confirmed by recent review studies on Nearly Zero Energy Buildings design across Europe [32], which has highlighted that the heat pump is a key technology for the cost-optimal design solutions of residential buildings in all climatic zones embracing the European countries, especially those of Southern Europe.

Heat pumps can extract energy from a variety of different sources. With an air-water heat pump, energy is extracted from the outside air to provide heat to warm up the building's water-based heating system and DHW system. This is achieved by allowing the outdoor air to pass across an air coil in the outdoor unit where energy is transferred to the heat pump's low-temperature side. The heat pump can operate reversely to extract heat from the building (cooling energy) that is released to the outside air. However, the performance of air-source heat pumps is strictly related to the fluctuations of outdoor temperature and its performance decreases as the outdoor temperature drops during cold weather or rises during hot weather [33].

With ground source heat pumps, energy can be extracted from several different sources that have higher inertia and are less dependent on the outdoor weather conditions: (a) soil [34][35], (b) groundwater [36], (c) surface water [37][38] and (d) sedimentary rock [39][40]. The most common ground source heat pumps for building's energy needs in cities use the soil or the groundwater as the ambient source. Because of the almost constant temperature that lies in the near-surface geothermal layer or in the groundwater, ground source heat pumps usually are expected to have higher coefficient of performances than air source heat pumps. Further, their performance is ideally more predictable because, once the source temperature of the location is known, it only depends on the estimation of the building loads and the related design operating conditions [41]. However, their installation is often subject to restrictions related to site characteristics and hydrogeological issues, which make their use more cost-effective when implemented at multifamily building scale or even at district level [42].

1.1 Performance indicators

Given this picture, potential benefits of using heat pumps in the residential sector are widely recognised and the latest sustainable development scenarios largely rely on their use [43]. However, a recent study reveals that uncertainty in estimating the performance of such systems when

performing decision making at the design stage can still be high [44], thus leading to a potential mismatch between predicted (as estimated at the design stage) and real (as assessed during operation) performance of the systems and therefore of the building as a whole. In fact, at the preliminary design stage, decision making often relies on preliminary estimation of running energy costs based on rated performance values reported in the equipment technical sheets provided by manufacturers of heat pump systems [45].

It is well known that rated efficiencies do not necessarily reflect the real operating conditions. The so called “ COP_{rated} ”/“ EER_{rated} ” is defined in EN 14511 [46] as “the declared capacity of heating/cooling divided by the rated power input for heating/cooling of a unit providing heating/cooling at the standard rating conditions”. Such conditions are standardised for the purpose of rating and comparing the different units provided by the different manufacturers. Other COP/EER values are usually declared by manufacturers to indicate “the ratio of heating/cooling capacity to the effective power input of the unit” in other operating conditions, among which designers can find the expected performance of the system at the expected design operating conditions. In recent years, for multipurpose units producing heating and cooling as useful effects at the same time, the so-called “total efficiency ratio” (TER) has been introduced in certification rating standards [47] (see details in § 2.4).

In order to account for variable operating conditions and better estimate the average system efficiency over a heating and/or cooling season, seasonal efficiency values (SCOP and/or SEER) were introduced and updated in subsequent versions of Standard EN 14825 [48]. Their calculation is based on considering the system working at different operating conditions for a different amount of time throughout the entire season according to the climate zone.

The Seasonal Performance Factor (SPF) also aims at representing the performance of a system over a period of time and was defined in the EU SEPOMO-Build project [49] as “the ratio of the total useful energy output to the total energy input of a system”. This was embraced in different IEA

programmes (HPT Annexes [50] and SHC Tasks [51]), also studying multipurpose units, and is often used to represent the performance of a system in real operation. This usually follows system monitoring and can be compared to the system performance estimated at the design stage.

1.2 Performance evaluation

When studying large renovation plan at the building stock scale and in any case at the early design stage, designers usually adopted rated efficiencies or, if available, declared COP and/or EER values from manufacturers at the design operating conditions, in order to provide an estimation of the performance of the system (and therefore of the expected energy costs).

When put in operation, what is called a “performance gap” is often experienced as the real performance can be significantly lower than the estimated one, with higher running energy costs than expected and causing the real decarbonisation process to be significantly lower than expected, with important implications on short- and long-term energy policies.

That is why it is crucial that the performance based on which the early design decisions are made result to be realistic and the performance gap is reduced as much as possible. The ongoing process of refinement of seasonal performance indicators in the regulatory systems and of building performance simulation tools, which have been demonstrated to be able to effectively support the design of such systems with a high level of details [52], cannot be done without validation based on real data obtained outside laboratory when systems are put in operation. However, available performance data from a great number of case studies are still hard to find in the literature, especially for large ground source systems in city districts, as also highlighted in recent studies [53]. This need has been also recognised by the IEA HTP programme, which has recently initiated the ongoing Annex 52 [54] on the long term performance measurements of GSHP systems, based on the concept that for understanding the critical issues and delineate strategies for an optimised system integration in

the real operation context it is crucial to collect data about the operation of such systems under real working conditions and get experimental evidence from different contexts and building uses [55]. This is even more crucial for unconventional systems like multi-purpose units.

1.3 Aim and approach

It has been recognised that the effectiveness of carbon emissions reduction related to conventional heating and cooling technologies is firstly dependent on the carbon emission factor of the electricity grid and, secondly, on the efficiency of alternative technologies in realistic operating conditions. Consequently, evidence-based policy and industry practice can benefit from monitoring and analysis of new clean technologies. This is particularly important for multipurpose heat pump that are able to provide with the same system DHW, space heating energy and/or space cooling energy. There is a very limited knowledge of such systems in the literature, especially as regards the long term performance from monitoring.

The primary aim of our research was to collect data that can contribute to this evidence in the case of larger groundwater multipurpose systems used for heating, cooling, and DHW. This work investigates the real performance of a multipurpose groundwater system in a new district of multifamily buildings in the North of Italy, which was considered as representative of the best practice of recent construction of this building typology in the Italian context.

The paper analyses the system performance during real operation by reporting the results of two different monitoring campaigns between 2017 and 2018. The survey includes data about thermal energy consumption for space heating, domestic hot water, space cooling, and electricity consumption for the three operating modes of such multi-purpose groundwater heat pumps (SH+DHW; DHW only; SC+DHW) in order to determine whether and the extent to which the performance during real operation is satisfactory with respect to that estimated at the preliminary design stage. After the first monitoring season, some modifications to the control logic of the system

(groundwater heat pumps and auxiliaries) were made based on the obtained data, so that the impact of different operation strategies on the overall system performance could be assessed through monitoring of the following season.

In the discussion, the importance of delineating new solutions for improving the prediction capability of the design process, optimising the system integration in the operating context, and therefore reducing the performance gap between design and operation have been highlighted.

2. The case study

2.1 The residential district

The case study for the analysis is a set of multifamily buildings composed of more than 300 flats, the buildings are located in Milan (North of Italy, around 2,400 degree days) and consist of 18 blocks of flats, clustered in 7 sectors from A to G as shown in Fig. 2. Their construction was completed in 2014 according to high energy performance standards (the buildings were assigned to class A in their energy performance certificates according to Italian regulation **Error! Reference source not found.**). Because the intervention was coordinated by one of the greatest social housing investors in the area, buildings can be considered as representative of new constructions of the multifamily building typology in the region.

Each sector is connected to a central heating system that relies on multipurpose groundwater heat pumps to supply thermal energy for space heating and/or DHW during the winter season, DHW during the mid-season, and space cooling and/or DHW during the summer season. Table 1 reports for each sector the total area and volume, the conditioned area (CA) and volume (CV) and the occupied conditioned area (OCA) at the end of year 2016.

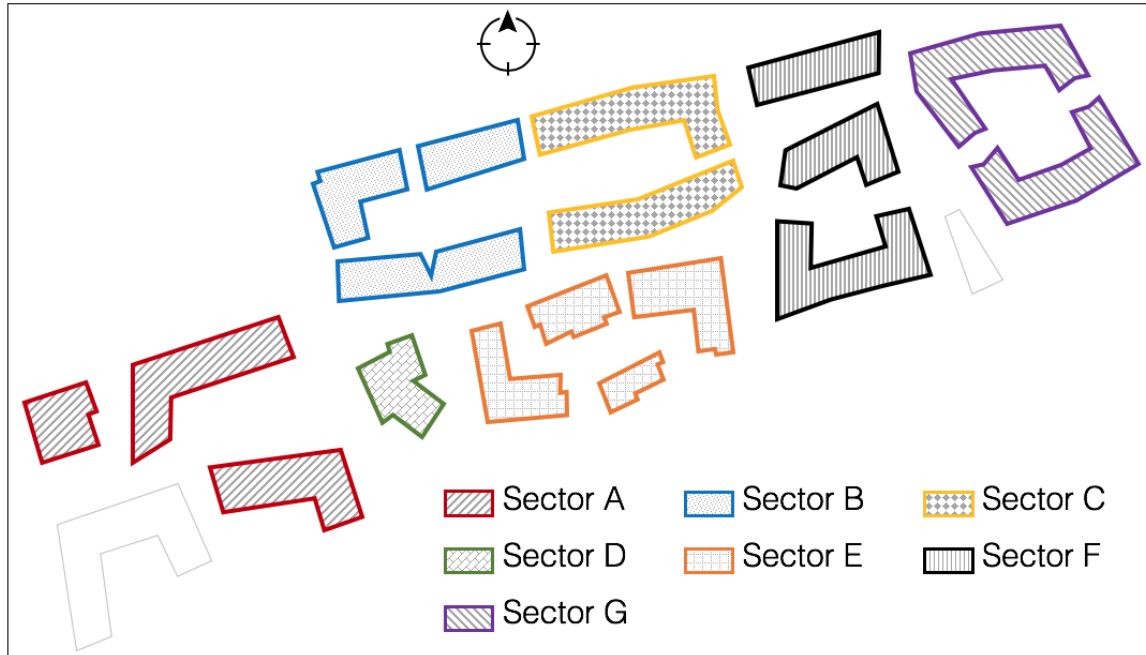

Figure 2. Planimetry of the set of multifamily buildings divided by sectors.

Table 1. Conditioned area (CA) and volume (CV), and occupied conditioned area (OCA) of the multifamily complex per each sector shown in Fig. 2.

Sector	Total area [m ²]	Total volume [m ³]	CA [m ²]	CV [m ³]	OCA in 2016/17 [m ²]
A	6,533	19,599	5,954	16,076	4,374
B	3,562	10,868	3,028	8,176	2,212
C	3,686	11,058	3,134	8,461	1,526
D	677	2,031	575	1,553	n/a
E	3,468	10,404	2,949	7,962	1,806
F	4,574	13,722	3,890	10,503	1,965
G	3,870	11,610	3,291	8,886	2,706

2.2 The heating and cooling plants

Seven heating and cooling plants, one for each sector (Fig. 2), were located in the basement of seven multifamily buildings, and are composed of two groundwater heat pumps, two plate heat exchangers to connect the heat pumps to the groundwater source, two DHW tanks (one as back-up) and one water tank that connects the heat pumps and the DHW tanks. Figure 3 shows mechanic and hydraulic links between each component of the thermal plants. The rated efficiency data for heating and/or cooling operations of the installed groundwater heat pumps are reported in Tables 2 and 3, respectively, for the expected design operating conditions. According to the above-mentioned Standard, only a fraction of the power input (proportional to the static pressure drops) to the pump motor is added to the power absorbed by the heat pump compressor.

Since heat pumps use groundwater as the source for renewable energy, the seven plants are connected in parallel to a groundwater ring loop that communicates with the aquifer by means of two wells; one well is used for water suction from the aquifer while the second one is used for water injection into the aquifer. Since the pH and limestone level of the groundwater could damage and/or obstruct the hydraulic circuit of the heat pump (even after a filtering section), two plate heat exchangers (one as back-up) were installed between the groundwater ring loop and the heat dissipation circuit of the heat pump as reported in Fig. 3.

The installed heat pumps are equipped with two scroll compressors of different size, simultaneously working when the required building thermal load is higher than the 66% of the rate heat pump capacity both for heating and cooling mode. To optimise the energy performance at partial load, the sole small compressor runs when the thermal load does not exceed the 33% of the rate heat pump capacity. In each plant, the two heat pumps cover space heating and/or DHW during the winter season, DHW during the mid-season, and space cooling and/or DHW during the summer season;

moreover, they were set to work in parallel for the purpose of increasing efficiency by running together at part load and for backup in case of failure of one of them.

2.2.1 Heat pumps working configuration

The installed heat pumps are equipped with three onboard flat plate heat exchangers that are connected to three small pumps (also named as onboard auxiliaries) having a power of about 500 W each that guarantee and regulate the water flow rate entering the three heat exchangers. The three pumps run for 100% of the time during the heat pumps' operations (from 5 am to 11 pm), and the monitored water temperature exiting the three heat exchangers allows both the heat pumps and the onboard pumps to be regulated.

The three heat exchangers work as follows:

i) one heat exchanger is hydraulically connected to the manifold that provides hot water to the apartments' radiant panels at around 40 °C for space heating during winter (Fig. 3a). The same manifold is used during summer to provide cold water to the apartments at around 10 °C for space cooling (Fig. 3c). Therefore, such heat exchanger operates as a condenser (named COND in Fig. 3a) during the winter season and as an evaporator (named EVAP in Fig. 3c) during the summer season;

ii) one heat exchanger operates as desuperheater (named DSH in Fig. 3) and is hydraulically connected to the water tank as shown in Fig. 3. The desuperheater recovers heat from the refrigerant exiting the heat pump compressor, thus allowing the water tank to be maintained at a temperature higher than 50 °C. The water tank, installed between the heat pumps and the DHW tanks, helps in maintaining the DHW tanks temperature within the range of 42÷45 °C. The installed water tank and DHW tanks avoid several start-stop phases of the heat pump compressor when the DHW is required for short periods;

iii) the last heat exchanger, hydraulically connected to the two heat exchangers HX1 and HX2 that divide the groundwater ring loop and the heat pumps (Fig. 3), works as an evaporator (named EVAP in Fig. 3a and 3b) during the winter and mid-seasons to absorb heat from the groundwater and as a condenser (named COND in Fig. 3c) during the summer season to discharge heat to the groundwater.

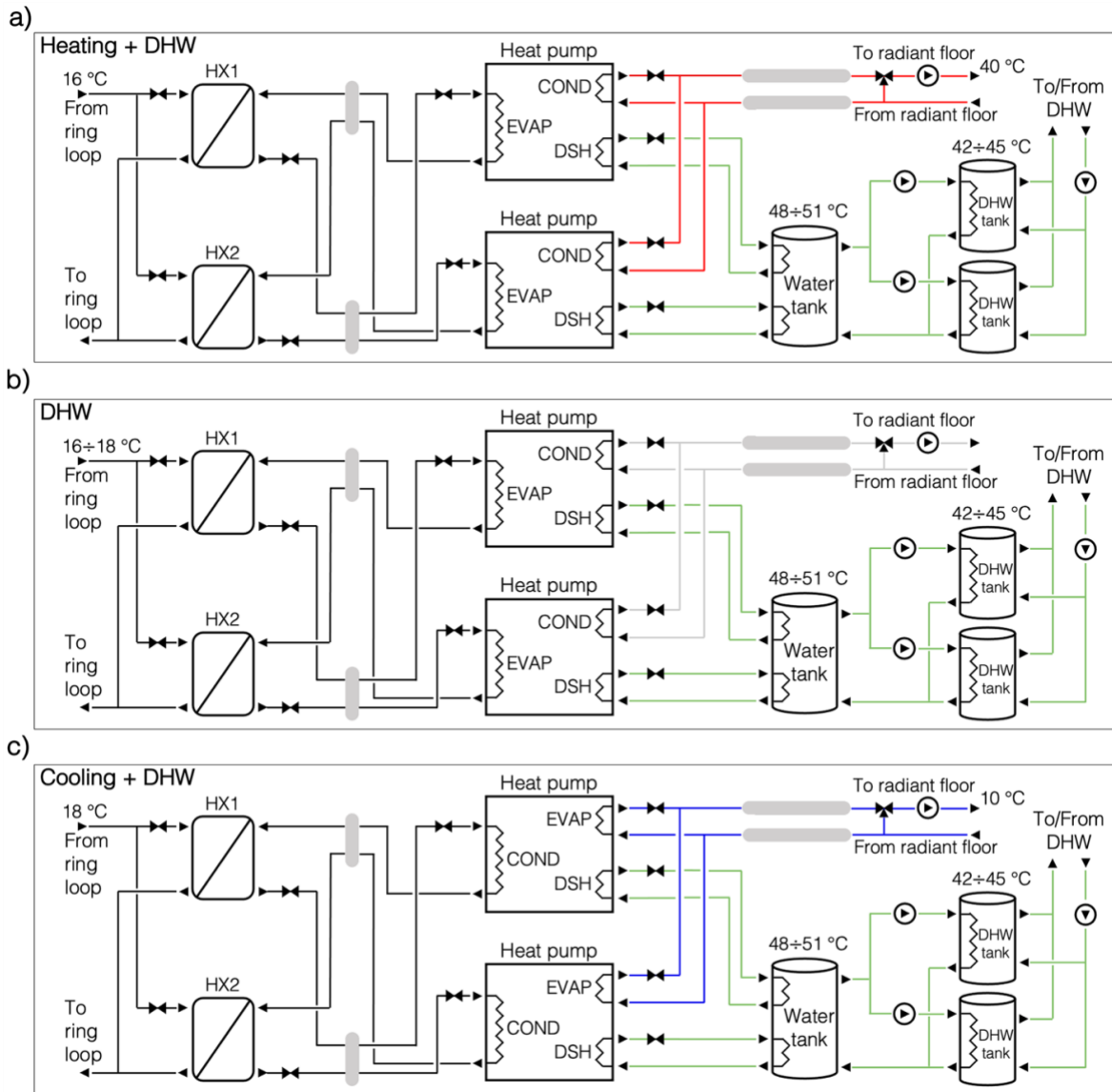

Figure 3. Layout of the thermal plant for each sector of the residential multifamily buildings in the three different operation modes: (a) Space heating + Domestic Hot Water (winter season), (b) Domestic Hot Water-only (mid-season), and (c) Space cooling + Domestic Hot Water (summer season).

During the winter season, the pressure level of the heat pumps thermodynamic cycle is set to be able to supply hot water for space heating at 40 °C. However, when the temperature of the water tank and of DHW tanks reduces due to DHW demand from the users, the working pressure level of the heat pumps thermodynamic cycle increases to supply water at a temperature higher than 50 °C. In the mid-season, the heat pumps only run to supply hot water at high temperature for the DHW demand. During summer, the heat pumps set to provide cold water at 10 °C and hot water for DHW at a temperature higher than 50 °C. When only cooling energy is required, the heat pumps thermodynamic cycle is set to operate at a lower condensing pressure to increase its performance. The rated heating cooling and heating capacities and efficiency values for these operating conditions are reported in Table 2 and 3.

This description of the various operating modes of the same multi-purpose heat pump makes it clear that it is quite difficult, at the initial stage, to estimate accurately the yearly energy performance and the various energy efficiencies of such plants and compare this one with other types of primary plants. At the same time, reliable energy efficiency data in real operating conditions can only be obtained from monitoring, as the ones reported in this paper.

Table 2. Rated heating capacity of the installed groundwater heat pumps in each sector of the residential multifamily buildings (Fig. 2) at the expected operation conditions.

Sector	Groundwater [°C]	Hot water temperature: 45 °C			Hot water temperature: 55 °C		
		Heating [kW]	Electricity [kW]	COP [-]	Heating [kW]	Electricity [kW]	COP [-]
A	16	211.0	42.7	4.94	196.0	52.4	3.74
B	16	101.0	20.5	4.93	93.6	25.1	3.73
C	16	101.0	20.5	4.93	93.6	25.1	3.73
D	16	37.6	7.6	4.93	35.6	9.7	3.68

E	16	101.0	20.5	4.93	93.6	25.1	3.73
F	16	149.0	30.2	4.93	138.0	36.9	3.74
G	16	132.0	26.7	4.94	123.0	32.8	3.75

Table 3. Rated cooling capacity of the installed groundwater heat pumps in each sector of the residential multifamily buildings (Fig. 2) at the expected operation conditions.

Sector	Chilled water temperature: 10 °C							
	Hot water temperature: 30 °C				Hot water temperature: 55 °C			
	Cooling [kW]	Electricity [kW]	EER [-]	Heating [kW]	Cooling [kW]	Electricity [kW]	EER [-]	Heating [kW]
A	190	33.5	5.67	224	143	51.9	2.76	195
B	90	15.4	5.84	105	68.3	24.4	2.80	92.7
C	90	15.4	5.84	105	68.3	24.4	2.80	92.7
D	32.8	5.59	5.87	38.4	23.8	9.93	2.40	33.8
E	90	15.4	5.84	105	68.3	24.4	2.80	92.7
F	134	23.3	5.75	158	102	36.1	2.83	138
G	117	20.6	5.68	138	88.7	32.2	2.75	121

Heating capacity refers to the heat that can be recovered for DHW.

2.3 Monitoring system

A power meter and data logger was installed in each plant in order to measure the electricity consumption of the compressor and onboard auxiliaries of the heat pumps; the power meter was placed in-line prior to the monitored heat pump. The electricity consumption data were collected every fifteen minutes (accuracy of $\pm 1.5\%$).

A thermal energy data logger was also installed in sectors A and B to evaluate the energy performance of the heat pumps. The thermal energy meter consists of a flow measuring section, two connected temperature sensors and an integrated processor which, based on flow rate and temperature differential, calculates the energy consumption. The meter was installed to measure the

thermal energy produced by the heat pump for space heating and DHW during winter, for DHW in the mid-season, and for space cooling and DHW during summer. The meter set to provide data with a step of 1 MWh of produced thermal energy ($\pm 5\%$ accuracy).

Measurements of the thermal energy for space heating, DHW, space cooling and electricity were taken starting from March to June 2017. The monitoring campaigns were planned so to analyse a period of the winter season (the presented case study is located in the Pianura Padana zone in which thermal plant operations for space heating are allowed from 15 October to 15 April (DPR 412/93)), a period of mid-season when only DHW is required and also part of the summer season.

In order to collect operational data under the original design configuration of the heat pumps, no modifications to the hydraulic layout of the plant (Fig. 3) and no changes to the heat pumps setting were done in 2017 after the thermal energy meters being installed. Some modifications to the heat pumps setting were done subsequently during the second monitoring campaign, from January to July 2018.

The data collected from the central unit of the electricity and thermal energy data loggers installed in sectors A and B were examined; cleaning the recorded data was required in some cases due to heat pumps being switched off for maintenance service or occasional faulty periods of monitoring.

2.4 Key performance indicator

The overall performance of the system over the different monitoring periods was assessed based on the concept of the Seasonal Performance Factor, which is to determine “the ratio of the total useful energy output to the total energy input of a system”. In the SPF definition provided by the SEPEMO-BUILD project [49], it is mentioned that for multipurpose systems operating simultaneously in cooling and heating mode, e.g. for heating domestic hot water while providing space cooling, the fraction of heat delivered to the system has to be considered among the useful effect.

With the increasing success of multipurpose systems, this concept has been recently embraced by the third-party certification company Eurovent, which updated certification standards [47] including a new parameter called TER (total efficiency ratio) as a certified performance parameter for multipurpose units.

This parameter considers the sum of the useful effects over the entire system and the total electrical energy expenditure calculated over a defined period of time, as follows

$$TER = \frac{\int_0^T Q_h dt + \int_0^T Q_{dhw} dt + \int_0^T Q_c dt}{\int_0^T P_{el} dt} \quad (1)$$

where

- Q_h is the space heating demand over the defined monitoring the time period T (one week in the presented case study);
- Q_{dhw} is the heating demand for domestic hot water over the time period T ;
- Q_c is the space cooling demand over the time period T ;
- P_{el} is the electricity consumption of the heat pumps compressors + the on-board auxiliaries of the heat pumps over the time period T .

The adoption of TER represents an advanced rating method accounting for the simultaneous production of chilled and hot water where traditional efficiency parameters such as COP or EER would be limiting and has been recently used in scientific literature as a key performance indicator for multipurpose systems [56].

In the system analysed in this paper, space heating and space cooling never occur at the same time and therefore they have been alternatively set to zero in winter or summer, but the condition for simultaneous loads for DHW and space heating/cooling is usual all year long.

3. Results

3.1 First monitoring campaign

Based on valid data of the monitoring campaign conducted in the year 2017, Fig. 4 reports the obtained TER values. In sector A (Fig. 4a), TER values were in the range [1.94, 3.39] and [2.63, 3.46] when the heat pumps operated respectively in the space heating + DHW or space cooling + DHW mode. In sector B (Fig. 4b), TER values were also lower than expected with values ranging from [2.03, 2.98] in the space heating + DHW mode, [1.79, 1.84] in the DHW mode, and [2.45, 3.33] in the space cooling + DHW mode.

The energy performances of the heat pumps were found to vary according to the period the survey was carried out (Fig. 4). The highest TER values were associated with heat pumps being monitored during the winter season (from March to mid-April). The differences were due to the considerable variation between the thermal load required to the heat pumps during winter (space heating + DHW) and the one required during spring (only DHW, end of April and May). Indeed, when the thermal load for space heating is null or very low (in the mid-season, space heating was only required in the morning and/or evening), the heat pumps compressors were found to run at partial load for very short period of time (even lower than 2 minutes) in which unsteady-state phenomena occur causing poor compressor lubrication (several compressors' breakage were detected from 2015 to 2017) and increasing power consumption. The differences are also related to the thermodynamic cycle of heat pumps, which is less efficient since the heat pump only runs to supply hot water at 55 °C. During the summer season, the low TER values could be related to a low space cooling demand (several households declared that they did not turn on the cooling system to save money) which involves a poor performance of the heat pumps compressor when operating at a low partial load (< 30% of the rated capacity).

The relationship between part load ratio (PLR) of the heat pumps of sectors A and B and the obtained TER values can be seen in Fig. 5; data of the winter and mid seasons were plotted in the same chart (Fig. 5a) while data of the summer season were plotted in Fig. 5b. The part loads values were calculated according to the standard system capacities reported in Tables 2 and 3 and the average thermal capacity provided by the heat pumps during the monitored period (thermal energy reported in Fig. 4 to the number of hours in which the heat pumps were running).

Figure 5 shows as the PLR of the heat pumps of sectors A and B was never higher than 0.7, with most of the values being lower than 0.5 and therefore associated to low performances in most of the analysed periods. However, it can be noticed in Fig. 5a as the TER values trend increases with increasing the PLR of the heat pumps ($R^2 > 0.65$); this was not found in the case of TER values during the summer season (Fig. 5b, $R^2 < 0.15$).

Looking at the obtained results reported in Figs. 4 and 5, it can be noticed that there was a very high variation (up to 60%) between how the heat pumps really worked and how they could have theoretically worked according to the rated data. Such difference in energy performances have influenced the energy performance of the multifamily buildings leading to extra running and maintenance costs of the heat pumps. The main explanations of such results could be:

- the rated data of Tables 2 and 3 do not completely take into account the electricity consumption of the auxiliaries (the three onboard pumps) which run continuously even if the heat pump did not provide thermal energy;
- oversizing and setting of the heat pumps; indeed, they were set to work in parallel when the thermal loads exceed 33% of the rate capacity of one heat pump;
- regulation of the loop for DHW in terms of temperature setting of the water tanks (green loop in Fig. 3).

Based on such considerations, some modifications to the settings and control of the heat pumps were made, as explained in the following section, to improve their performances.

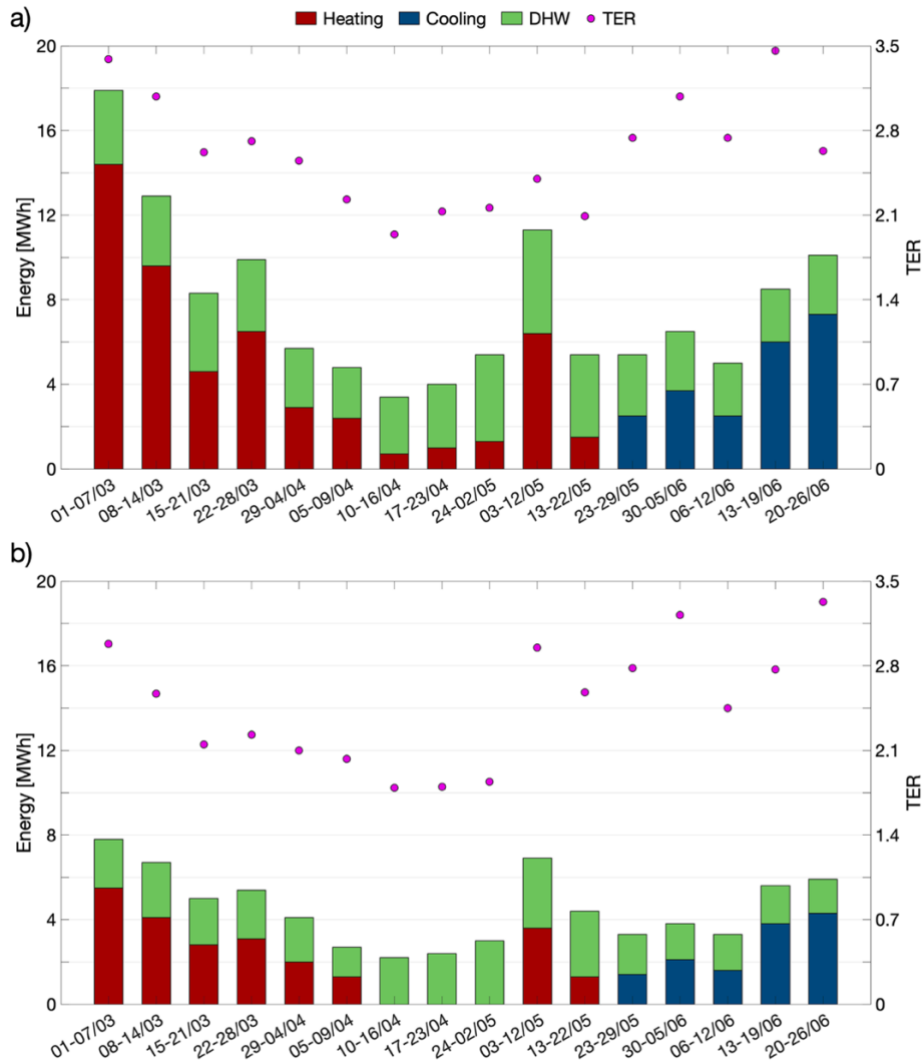

Figure 4. Thermal energy production [MWh] and electricity consumption [MWh] of the first monitoring campaign in sector A (a) and in sector B (b).

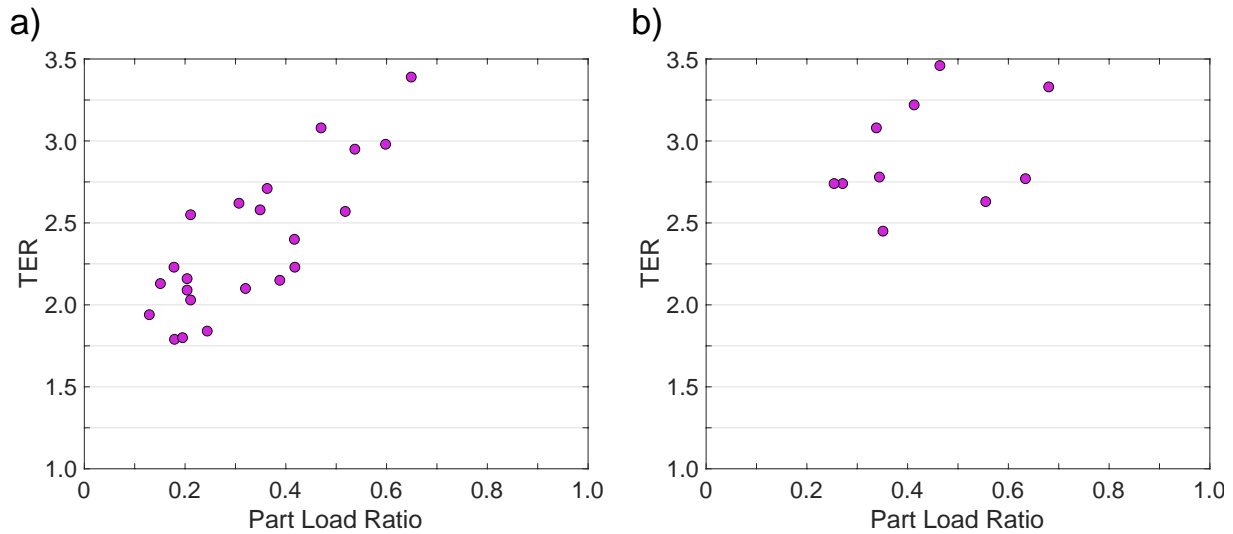

Figure 5. TER and PLR values monitored in sectors A and B during the year 2017 in the winter and mid seasons (a) and in the summer season (b).

3.2 Second monitoring campaign

In light of the low heat pumps' energy performance monitored during the first monitoring campaign (§ 3.1), a second monitoring campaign was done in 2018 modifying the heat pumps' setting. Following the same criteria used for the first campaign, this second experimental campaign was planned to monitor the heat pumps in sectors A and B during:

- winter season (January and February): the heat pumps run to supply both the space heating and the DHW demands;
- mid-season (April): the heat pumps run to only supply the DHW demand;
- summer season (June and July): the heat pumps run to supply both the space cooling and the DHW demands.

The results of the second monitoring campaign are reported in the next paragraphs.

3.2.1 Winter season

Monitoring in the winter season was conducted over a period of three weeks, from 18 January to 7 February 2018. Simultaneous measurements of the electricity consumption, as well as the thermal energy for space heating and DHW were monitored in sectors A and B.

The heat pumps of sector A were set to work in parallel to supply the space heating and DHW demands without changing the setting used in the first monitoring campaign (§ 3.1). On the contrary, to evaluate whether the energy performance could be increased, the setting of the heat pumps in sector B was modified as follows:

- 1) only one heat pump was used to supply both the space heating and the DHW demands;
- 2) the heat pump was set to maintain the hot water tank (Fig. 3a) temperature within the range $47\div 52$ °C, which is different with respect to the one adopted in sector A ($48\div 51$ °C);
- 3) the auxiliary pump that allows and regulates the water flowing between the heat pump desuperheater (§ 2.2.1) and the hot water tank was stopped for 20 minutes once the upper setpoint temperature of the hot water tank (52 °C) was reached. This pump setting was disabled from 7 to 8 am and from 6 to 8 pm to avoid possible disservice when the DHW was high;
- 4) no modifications to the hydraulic layout of the plant were done.

Figure 6 reports the results of the monitoring campaign during winter, from January to February 2018. It can be observed that the TER values in sector B were on average about 19% higher than the ones monitored in sector A. The difference in the energy performance between the two sectors was due to the modified heat pump setting in sector B, which allowed to: (i) avoid the compressor running at very low partial load in unsteady state conditions when poor lubrication and low efficiency occur, (ii) reduce the electricity consumption of the auxiliary pump that regulates the water flow rate

between the heat pump desuperheater and the hot water tank, and (iii) improve the regulation of the loop for DHW.

The use of a single heat pump running, and its modified regulation, were found to be a more efficient configuration than the one with two heat pumps running in parallel at low partial load.

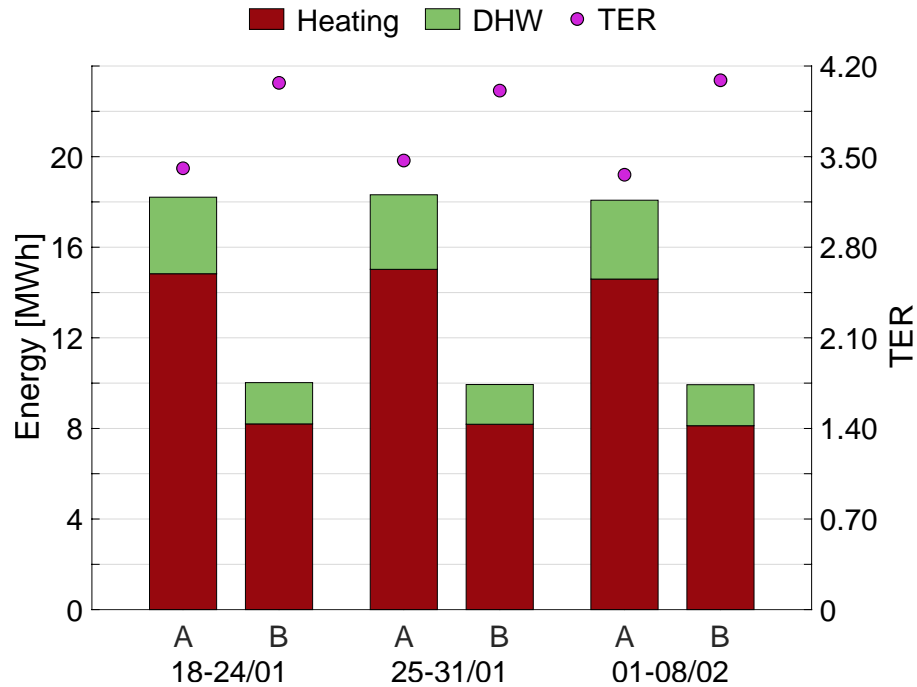

Figure 6. Monitored energy [MWh] for space heating and DHW in sectors A and B during the winter season in the second monitoring campaign.

3.2.2 Mid-season

Monitoring was done in April 2018 to evaluate the energy performance of the heat pumps in sectors A and B for the sole DHW production. No modifications to the setting of the heat pumps installed in sector A were done while the setting of the heat pumps in sector B was modified as follows:

- 1) only one heat pump was used to supply the DHW demand;

- 2) the temperature range of the hot water tank and the auxiliary pump that regulates the water entering the hot water tank were set in accordance with the results obtained in the winter monitoring campaign (§ 3.2.1);
- 3) the pumps installed between the hot water tank and the DHW tank were regulated to maintain the DHW tank temperature within the range $41 \div 45$ °C from 9 am to 6 pm, and within $42 \div 45$ °C from 5 am to 9 am and from 6 pm to 11 pm to avoid disservice. The temperature range in Sector A was $42 \div 45$ °C from 5 am to 11 pm;
- 4) no modifications to the hydraulic layout of the plant were done.

The results of the monitoring campaign during April 2018 are reported in Fig. 7. The TER values in sector B were found to be higher than 2.9 for the entire period the heat pump was monitored. This means that they were on average 35% higher than the values obtained in sector A.

The results reported in Fig. 7 for Sector B were also 65% higher than the values monitored in April 2016/17, which were reported in Fig. 4. This was due to the improved regulation of the DHW loop, such as water tanks temperature set point and pumps start-stop logic, that allowed a reduction in electricity consumption of the heat pump and auxiliaries to be obtained. Moreover, the adoption of only one heat pump increased the energy performance in the DHW production at partial loads.

TER values in Fig. 7 are on average 1 point lower than the values in Fig. 6; this is due to the combination of two phenomena: the thermodynamic cycle efficiency (hot water production at 55 °C is less efficient) and the operation at partial loads.

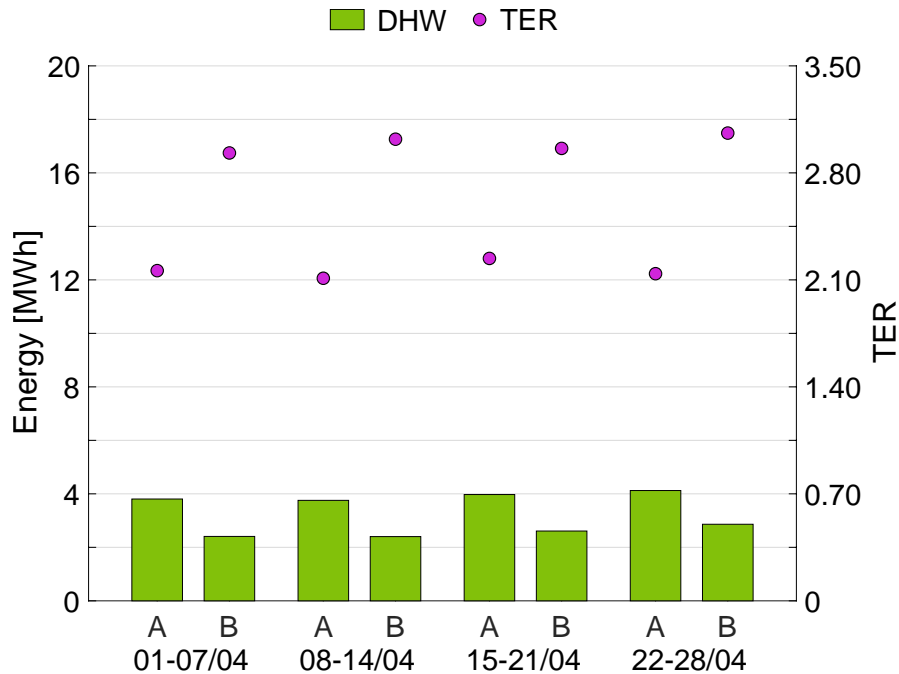

Figure 7. Monitored energy [MWh] for DHW in sectors A and B during the mid-season in the second monitoring campaign.

3.2.3 Summer season

Monitoring in summer season was conducted over a period of 5 weeks, from 13 June to 16 July 2018. Simultaneous measurements of the electricity consumption and thermal energy for space cooling and DHW were monitored in sectors A and B. No modifications to the setting of the heat pumps in sector A were applied while the setting in sector B was modified as follows:

- 1) only one heat pump was used to supply the space cooling and DHW demand;
- 2) the regulation of the loop for DHW was improved as described in § 3.2.2;
- 3) the regulation of the three-way valve, the one installed at the outlet of the discharge manifold (Fig. 3c), was modified. The three-way valve mixes the chilled water exiting the discharge manifold with the water returning from the apartments' radiant panels as a function of the outdoor

- air temperature; such regulation was disabled, and the valve left fully to increase the volume of water to be chilled and consequently the cooling energy demand;
- 4) the set point of the chilled water exiting the heat pump was increased from 10 °C to 12 °C;
 - 5) no modifications to the hydraulic layout of the plant were done.

Figure 8 reports the results referring to the summer season.

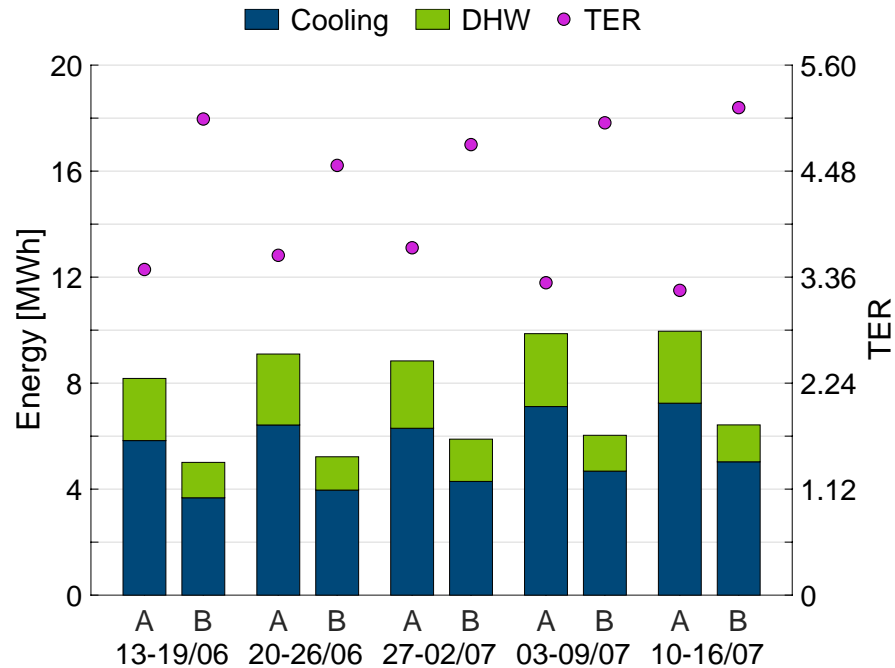

Figure 8. Monitored energy [MWh] for space cooling and DHW in sectors A and B during the summer season in the second monitoring campaign.

TER values were found to be within the range 3.2÷3.7 in sector A and 4.5÷5.2 in sector B. The maximum TER in sectors A and B were 3.67 and 5.15, respectively. There was a significant performance difference, more than 40%, and it was due to: (i) the increased setpoint of the chilled water exiting the heat pump, which increased the thermodynamic cycle efficiency; (ii) the improvement of the DHW loop regulation (see § 3.2.1 and § 3.2.2); (iii) an increase in the running time of the heat pump compressor avoiding unsteady state operations; this allowed the chilled water and, in the meanwhile, DHW to be produced at higher efficiency.

The results reported in Fig. 8 for Sector B were also found to be about 70% higher than the values monitored in June 2017, which were reported in Fig. 4. It was therefore demonstrated that the energy performance of a groundwater heat pump system as the analysed one strictly depends on the regulation of the plant and of auxiliaries' electricity consumption.

4. Discussion and conclusions

Data from a long-term monitoring of a multipurpose groundwater heat-pump system for a set of typical multifamily buildings in the North of Italy were reported. This contributes to give evidence of the real performance of such systems, since the analysed buildings can be considered as representative of the best practice of recent construction of this building typology in the Italian market. The first years of operation resulted in higher running energy costs of the thermal plants than expected from the building owner based on preliminary design estimations, leading to ask for deeper investigation on the reasons causing such lower energy performance.

Results demonstrate that the adopted plant scheme for such heat pump-user loop requires a careful design process, because the system efficiency under real operation can be significantly lower than declared COP and/or EER values, on which most decision making and performance estimation are based at the preliminary design stage. Usually, since declared efficiency values are considered for the design (full load) conditions, it may be expected that real performance is not significantly lower than expected, considering that the operation of new heat pumps equipped with highly efficient compressors at part load conditions, can be similar or higher than that at design conditions. However, evidence from these experimental data demonstrate that this may not be true.

In fact, real efficiencies were found up to 60% lower than expected ones and some modifications to the system control were proposed after one year of operation to improve the system efficiency, leading to a significant increase of the heat pumps performance with respect to the previous season

(on average +20%, +60% and +70% in the winter, mid and summer seasons respectively). In fact, since no changes to the hydraulic system of the heat pump heating and cooling plant could be done nor additional thermal energy storages to increase the heating loop thermal inertia could be installed, the only possibility was to modify the control strategy of some components of the heat pump system. The obtained results (from +20% to +70% in the energy performance after the changes to the control strategy of the heat pumps were applied) are beyond what the authors and the design chief engineer expected, thus proving as the control strategy of such an energy plant may deeply affect the energy performance.

This quantitative evidence confirms the fact that the performance of complex systems greatly depends on their control, which is a well-known concept that still have difficulties in being translated in standard design process. This reinforces the idea that an integrated design process (integrating best available technologies for building envelope and systems and control logic optimisation) that is able to support and optimise integrated design choices from design to operation is strongly needed to reduce the performance gap and drive towards highest efficiency targets.

The potential benefits of the use of detailed numerical simulation since the early design stage and throughout the entire process from design to operation, including the test of different control logics, also emerges from this study, as envisioned by latest updates of EU standards [57].

Concerning the design of the presented system, it was demonstrated that the use of heat pump systems with thermal energy recovery for DHW is not advantageous, as in the presented case study it would be better to use two different heat pumps (one for space heating/cooling and the other for DHW). In fact, in the second case (using two different heat pumps), it would be possible to recover thermal energy (from condenser) for DHW pre-heating, as the low-temperature source for the heat pump dedicated to DHW (like in VRV systems), by means of an intermediate thermal storage. The adoption of a heat pump dedicated to DHW would also allow the oversizing of the plant to be reduced.

Indeed, thermal plants are normally designed considering the worst scenario (winter and/or summer seasons), thus resulting oversized when only DHW is usually required (spring and autumn seasons). Without a doubt, as both investment and maintenance costs increase, running costs which should be lower due to higher system efficiency have to balance the extra costs.

The experimentation carried out on the thermal plants during real operation confirms the fact that heat pumps need thermal storages for maximising their efficiency. Thermal storages avoiding intermittent switching on/off preserve mechanic components from premature degradation with the consequent increase in maintenance costs (e.g. poor lubrication occurs when heat pumps run under unsteady state conditions). It was also observed that poor setting of the integrated system (heat pump + thermal storage + auxiliaries) reduces the system efficiency. Thermal storages are also necessary to optimise the integration with renewables such as solar thermal systems towards the objective of increasing the renewable energy ratio [56].

A further consideration regards the current methods for determination of rated values of COP by manufacturers, which cannot be representative of real operating conditions and do not always include auxiliary energy use (especially those Italian thermal plants which were designed before the incoming new regulations discussed in 2019). Auxiliary systems are mainly represented by circulation pumps, which have a non-neglectable energy demand especially if compared with the reduced heating/cooling demand in spring and autumn as shown by the reported data.

The last issue refers to the availability of data and their active role in decision making. Even if current practice for new buildings includes the possible installation of a monitoring system, many difficulties are often encountered because of the lack of planning of where and what install and how to use the collected data for improving and optimise the real building performance. Ideally, appropriately collected data could feed a calibrated detailed simulation model that could be used for advanced

system control strategies. The analysis of monitored data could be also very useful to heat pump manufactures to improve design solutions and control logic adapted to the specific application.

Acknowledgments

The authors would like to acknowledge Delta Controls SRL for providing energy consumption data of the groundwater heat pumps and Luigi Sgobaro for helping in the technical analysis of the energy system. Also, authors would like to express special thanks to Marco Filippi, Emeritus Professor at the Politecnico of Torino, for his willingness in the support of this research.

References

- [1] Yigit S, Ozorhon B. A simulation-based optimization method for designing energy efficient buildings. *Energy Buildings* 2018;178:216-27. <http://dx.doi.org/10.1016/j.enbuild.2018.08.045>.
- [2] Zhai ZJ, Helman JM. Implications of climate changes to building energy and design. *Sustain Cities Soc* 2019;44:511-9. <http://dx.doi.org/10.1016/j.scs.2018.10.043>.
- [3] Koulamas C, Kalogeras AP, Pacheco-Torres R, Casillas J, Ferrarini L. Suitability analysis of modeling and assessment approaches in energy efficiency in buildings. *Energy Buildings* 2018;158:1662-82. <https://doi.org/10.1016/j.enbuild.2017.12.002>.
- [4] Lisitano IM, Biglia A, Fabrizio E, Filippi M. Building for a Zero Carbon future: trade-off between carbon dioxide emissions and primary energy approaches. *Energy Procedia* 2018;148:1074-81. <https://doi.org/10.1016/j.egypro.2018.08.052>.
- [5] Cao X, Dai X, Liu J. Building energy-consumption status worldwide and the state-of-the-art technologies for zero-energy buildings during the past decade. *Energy Buildings* 2016;128:198-213. <https://doi.org/10.1016/j.enbuild.2016.06.089>.

- [6] <https://www.iea.org/data-and-statistics?country=ITALY&fuel=Energy%20consumption&indicator=Total%20consumption%20by%20end%20use%20-%20Residential> – accessed on April 2020
- [7] Hamid AA, Farsäter K, Wahlström A, Wallentén P. Literature review on renovation of multifamily buildings in temperate climate conditions. *Energy Buildings* 2018;172:414-31. <https://doi.org/10.1016/j.enbuild.2018.04.032>.
- [8] Wei S, Long N, Yang Y. Experimental research on the characteristics of single-well groundwater heat pump systems. *Energy Buildings* 2019;191:1-12. <http://dx.doi.org/10.1016/j.enbuild.2019.02.039>.
- [9] Calero M, Alameda-Hernandez E, Fernández-Serrano M, Ronda A, Martín-Lara MA. Energy consumption reduction proposals for thermal systems in residential buildings. *Energy Buildings* 2018;175:121-30. <https://doi.org/10.1016/j.enbuild.2018.07.028>.
- [10] Ferrara M, Sirombo E, Fabrizio E. Energy-optimized versus cost-optimized design of high-performing dwellings: The case of multifamily buildings. *Science and Technology for the Built Environment* 2018; 24(5): 513-528. <http://dx.doi.org/10.1080/23744731.2018.1448656>.
- [11] Thonipara A, Runst P, Ochsner C, Bizer K. Energy efficiency of residential buildings in the European Union – An exploratory analysis of cross-country consumption patterns. *Energy Policy* 2019;129:1156-67. <http://dx.doi.org/10.1016/j.enpol.2019.03.003>.
- [12] Ni L, Dong J, Yao Y, Shen C, Qv D, Zhang X. A review of heat pump systems for heating and cooling of buildings in China in the last decade. *Renew Energy* 2015;84:30-45. <https://doi.org/10.1016/j.renene.2015.06.043>.
- [13] Coccia G, D'Agaro P, Cortella G, Polonara F, Arteconi A. Demand side management analysis of a supermarket integrated HVAC, refrigeration and water loop heat pump system, *Appl Therm Eng* 2019; 152:543-550. <https://doi.org/10.1016/j.applthermaleng.2019.02.101>.
- [14] Koskela J, Rautiainen A, Järventausta P. Using electrical energy storage in residential buildings – Sizing of battery and photovoltaic panels based on electricity cost optimization. *Appl Energy* 2019;239:1175-89. <http://dx.doi.org/10.1016/j.apenergy.2019.02.021>.

- [15] Osseweijer FJW, van den Hurk LBP, Teunissen EJHM, van Sark WGJHM. A comparative review of building integrated photovoltaics ecosystems in selected European countries. *Renew Sust Energ Rev* 2018;90:1027-40. <http://dx.doi.org/10.1016/j.rser.2018.03.001>.
- [16] Liu J, Chen X, Cao S, Yang H. Overview on hybrid solar photovoltaic-electrical energy storage technologies for power supply to buildings. *Energy Convers Manage* 2019;187:103-21. <https://doi.org/10.1016/j.enconman.2019.02.080>.
- [17] Buonomano A, Forzano C, Kalogirou SA, Palombo A. Building-façade integrated solar thermal collectors: Energy-economic performance and indoor comfort simulation model of a water based prototype for heating, cooling, and DHW production, *Renew Energy* 2019; 137:20-36. <https://doi.org/10.1016/j.renene.2018.01.059>.
- [18] Murugan S, Horák B. A review of micro combined heat and power systems for residential applications. *Renew Sust Energ Rev* 2016;64:144-62. <http://dx.doi.org/10.1016/j.rser.2016.04.064>.
- [19] Biglia A, Caredda FV, Fabrizio E, Filippi M, Mandas N. Technical-economic feasibility of CHP systems in large hospitals through the Energy Hub method: The case of Cagliari AOB. *Energy Buildings* 2017;147:101-12. <http://dx.doi.org/10.1016/j.enbuild.2017.04.047>.
- [20] Casini M. Active dynamic windows for buildings: A review. *Renew Energy* 2018;119:923-34. <http://dx.doi.org/10.1016/j.renene.2017.12.049>.
- [21] Pan S, Han Y, Wei S, Xia L, Xie L, Kong X, et al. A model based on Gauss Distribution for predicting window behavior in building. *Build Environ* 2019;149:210-9. <http://dx.doi.org/10.1016/j.buildenv.2018.12.008>.
- [22] Abu-Jdayil B, Mourad AH, Hittini W, Hassan M, Hameedi S. Traditional, state-of-the-art and renewable thermal building insulation materials: An overview. *Constr Build Mater* 2019;214:709-35. <http://dx.doi.org/10.1016/j.conbuildmat.2019.04.102>.
- [23] Evin D, Ucar A. Energy impact and eco-efficiency of the envelope insulation in residential buildings in Turkey. *Appl Therm Eng* 2019;154:573-84. <http://dx.doi.org/10.1016/j.applthermaleng.2019.03.102>.

- [24] Kavousian A, Rajagopal R, Fischer M. Ranking appliance energy efficiency in households: Utilizing smart meter data and energy efficiency frontiers to estimate and identify the determinants of appliance energy efficiency in residential buildings. *Energy Buildings* 2015;99:220-30. <http://dx.doi.org/10.1016/j.enbuild.2015.03.052>.
- [25] Biglia A, Gemmell AJ, Foster HJ, Evans JA. Temperature and energy performance of domestic cold appliances in households in England. *Int J Refrig* 2018;87:172-84. <http://dx.doi.org/10.1016/j.ijrefrig.2017.10.022>.
- [26] Biglia A, Gemmell AJ, Foster HJ, Evans JA. Energy performance of domestic cold appliances in laboratory and home environments. *Energy* 2020; 204: 117932. <https://doi.org/10.1016/j.energy.2020.117932>.
- [27] Schimidt M, Åhlund C. Smart buildings as Cyber-Physical Systems: Data-driven predictive control strategies for energy efficiency. *Renew Sust Energy Rev* 2018;90:742-56. <https://doi.org/10.1016/j.rser.2018.04.013>.
- [28] Aguilera JJ, Kazanci OB, Toftum J. Thermal adaptation in occupant-driven HVAC control. *Journal of Building Engineering* 2019; 25:100846. <https://doi.org/10.1016/j.jobe.2019.100846>.
- [29] Ferrara, M.; Prunotto, F.; Rolfo, A.; Fabrizio, E. Energy Demand and Supply Simultaneous Optimization to Design a Nearly Zero-Energy House. *Applied Sciences*. 2019, 9, 2261. <https://doi.org/10.3390/app9112261>
- [30] Fabrizio E, Filippi M, Virgone J. Trade-off between environmental and economic objectives in the optimization of multi-energy systems. *Building Simulation* 2009;2:29-40. <http://doi.org/10.1007/S12273-009-9202-4>
- [31] IEA. Energy Technology Perspectives. <https://www.iea.org/topics/energy-technology-perspectives>.
- [32] Ferrara M, Fabrizio F. Cost-optimal nZEBs in future climate scenarios. *Energy Procedia* 2017;122:877-882. <https://doi.org/10.1016/j.egypro.2017.07.377>

- [33] Potočnik P, Vidrih B, Kitanovski A, Govekar E. Analysis and optimization of thermal comfort in residential buildings by means of a weather-controlled air-to-water heat pump. *Build Environ* 2018;140:68-79. <http://dx.doi.org/10.1016/j.buildenv.2018.05.044>.
- [34] Cui Y, Zhu J, Twaha S, Chu J, Bai H, Huang K, et al. Techno-economic assessment of the horizontal geothermal heat pump systems: A comprehensive review. *Energy Conv Manag* 2019;191:208-36. <http://dx.doi.org/10.1016/j.enconman.2019.04.018>.
- [35] Fabrizio E, Ferrara M, Urone G, Corgnati SP, Pronsati S, Filippi M. Performance Assessment of a Solar Assisted Ground Source Heat Pump in a Mountain Site, *Energy Procedia* 2015, 78, Pages 2286-2291. <https://doi.org/10.1016/j.egypro.2015.11.366>
- [36] Zhen J, Lu J, Huang G, Zhang H. Groundwater source heat pump application in the heating system of Tibet Plateau airport. *Energ Buildings* 2017;136:33-42. <http://dx.doi.org/10.1016/j.enbuild.2016.12.008>.
- [37] Schibuola L, Scarpa M. Experimental analysis of the performances of a surface water source heat pump. *Energ Buildings* 2016;113:182-8. <http://dx.doi.org/10.1016/j.enbuild.2015.12.048>.
- [38] Gauard A, Wüest A, Schmid M. Using lakes and rivers for extraction and disposal of heat: Estimate of regional potentials. *Renew Energ* 2019;134:330-42. <http://dx.doi.org/10.1016/j.renene.2018.10.095>.
- [39] Han C, Yu XB. Performance of a residential ground source heat pump system in sedimentary rock formation. *Appl Energ* 2016;164:89-98. <https://doi.org/10.1016/j.apenergy.2015.12.003>.
- [40] Casasso A, Sethi R. Efficiency of closed loop geothermal heat pumps: A sensitivity analysis. *Renew Energy* 2014;62: 737-746. <https://doi.org/10.1016/j.renene.2013.08.019>.
- [41] Daniel Rohde, Trond Andresen, Natasa Nord, Analysis of an integrated heating and cooling system for a building complex with focus on long-term thermal storage, *Appl Therm Eng* 2018: 145, 791-803, <https://doi.org/10.1016/j.applthermaleng.2018.09.044>.

- [42] Fraga C, Hollmuller P, Schneider S, Lachal B. Heat pump systems for multifamily buildings: Potential and constraints of several heat sources for diverse building demands. *Appl Energy* 2018;225:1033-53. <https://doi.org/10.1016/j.apenergy.2018.05.004>.
- [43] Epting J, Müller MH, Genske D, Huggenberger P. Relating groundwater heat-potential to city-scale heat-demand: A theoretical consideration for urban groundwater resource management. *Appl Energy* 2018;228:1499-1505. <https://doi.org/10.1016/j.apenergy.2018.06.154>.
- [44] Zhang Y, Akkurt N, Yuan J, Xiao Z, Wang Q, Gang W. Study on model uncertainty of water source heat pump and impact on decision making. *Energy Buildings* 2020;216:109950. <https://doi.org/10.1016/j.enbuild.2020.109950>.
- [45] UNI/TS 11300 – Italian standards about energy performance of buildings. <https://www.cti2000.eu/la-uni-ts-11300/>
- [46] UNI EN 14511-2013. Air conditioners, liquid chilling packages and heat pumps for space heating and cooling and process chillers, with electrically driven compressors.
- [47] S.A.S. Eurovent Certita Certification, Rating Standard for the Certification of Liquid Chilling Packages and Hydronics Heat pumps, 2019.
- [48] UNI EN 14825-2013. Air conditioners, liquid chilling packages and heat pumps, with electrically driven compressors, for space heating and cooling - Testing and rating at part load conditions and calculation of seasonal performance.
- [49] Zottl A, Nordman R. D4. 2/D 2.4. Concept for evaluation of SPF Version 2.2. Tech. rep.of the SEPOMO-BUILD Project, 2012, Intelligent Energy Europe, contract Nr. IEE/08/776/SI2.529222.
- [50] <https://heatpumpingtechnologies.org>
- [51] <https://www.iea-shc.org>
- [52] Lin Y, Wang H, Hu P, Yang W, Hu Q, Zhu N, Lei F. A study on the optimal air, load and source side temperature combination for a variable air and water volume ground source heat pump system, *Appl Therm Eng* 2020; 178: 115595, <https://doi.org/10.1016/j.applthermaleng.2020.115595>.

- [53] Selvaraj S. Naicker, Simon J. Rees, Performance analysis of a large geothermal heating and cooling system, *Renewable Energy*, Volume 122, 2018, Pages 429-442, ISSN 0960-1481, <https://doi.org/10.1016/j.renene.2018.01.099>.
- [54] <https://heatpumpingtechnologies.org/annex52/>
- [55] Zou PXW, Xu X, Sanjayan J, Wang J. Review of 10 years research on building energy performance gap: Life-cycle and stakeholder perspectives. *Energy Buildings* 2018;178:165-81. <https://doi.org/10.1016/j.enbuild.2018.08.040>.
- [56] Bilardo M, Ferrara M, Fabrizio E. Performance assessment and optimization of a solar cooling system to satisfy renewable energy ratio (RER) requirements in multi-family buildings. *Renew Energy* 2020;155:990-1008. <https://doi.org/10.1016/j.renene.2020.03.044>.
- [57] UNI EN ISO 52016-2017. Energy performance of buildings -- Energy needs for heating and cooling, internal temperatures and sensible and latent heat loads Calculation procedures