

A simplified procedure for the Accurate Frequency Response Identification of Voltage Transformers

Original

A simplified procedure for the Accurate Frequency Response Identification of Voltage Transformers / Crotti, Gabriella; Giordano, Domenico; Letizia, Palma Sara; Delle Femine, Antonio; Luiso, Mario. - (2020), pp. 50-54. (24th IMEKO TC4 International Symposium 22nd International Workshop on ADC and DAC Modelling and Testing IMEKO TC-4 2020).

Availability:

This version is available at: 11583/2890793 since: 2021-05-04T15:46:10Z

Publisher:

IMEKO

Published

DOI:

Terms of use:

This article is made available under terms and conditions as specified in the corresponding bibliographic description in the repository

Publisher copyright

(Article begins on next page)

A simplified procedure for the Accurate Frequency Response Identification of Voltage Transformers

G. Crotti¹, D. Giordano¹, P. S. Letizia^{1,2}, A. Delle Femine³, M. Luiso³

¹ INRIM, strada delle Cacce 91- 10135, Torino – Italy, ([g.crotti](mailto:g.crotti@inrim.it), [d.giordano](mailto:d.giordano@inrim.it), [p.letizia](mailto:p.letizia@inrim.it))@inrim.it

² Politecnico di Torino, c.so Duca degli Abruzzi Torino – Italy

³ Università degli studi della Campania “Luigi Vanvitelli”, Aversa (CE) – Italy, ([antonio.dellefemine](mailto:antonio.dellefemine@mario.luiso@unicampania.it), [mario.luiso](mailto:mario.luiso@unicampania.it))@unicampania.it

Abstract – The paper proposes a simplified and affordable procedure for instrument transformers frequency characterization for medium voltage applications. It consists of a two steps measurement procedure, where both steps involve the generation of sine waves only, so that it can be easily performed in instrument transformers calibration laboratories without requiring additional generation features. In the first step, a 50 Hz measurement of the Voltage Instrument Transformer ratio error at rated voltage is performed. The second step consists of a frequency sweep performed at low voltage up to the first resonance. By these two data sets, an approximated but accurate frequency response can be easily obtained using a non-linear fitted model. In the paper, a commercial voltage instrument transformer for medium voltage grids is characterized by the proposed method; results are shown and validated by comparison with a reference frequency characterization performed at INRIM under rated voltage.

Keywords— Power system measurement, Instrument Transformer, Harmonics, Voltage Measurement.

I. INTRODUCTION

High-frequency power converters, electronic non-linear loads, decentralized renewable energy sources are among the underlying causes of the significant increase of power grid harmonic pollution. As a result, harmonic levels assessment is a matter of growing importance for several power grid applications such as metering, monitoring, protection, and control. In medium voltage (MV) and high voltage (HV) grids, the quantification of the harmonic levels strongly depends on the performance and accuracy of the measurement chain that must always include sensors to reduce voltage and current to amplitude levels compliant with the low voltage input of the harmonic measuring instrumentation. For economic and practical reasons, inductive instrument transformers (ITs) already installed in HV e MV grid for metering and protection applications are often used also for harmonics and, more generally, for Power Quality (PQ)

measurements.

The accuracy performance of inductive ITs is affected by their intrinsic non-linearity, in the particular case of the frequently used ITs, not negligible ratio and phase errors can be introduced both at low and high frequency harmonics [1]-[4], consequently ITs errors should be measured under realistic condition. However, in most cases, ratio and phase errors of the ITs are just evaluated by carrying out a frequency sweep at low voltage under sinusoidal supply, not considering that non-linearity of the device can lead to additional deviations of the order of the percent. For this reason, tests have been identified [5] that involve the generation of non-standardized (non-sinusoidal, distorted) waveforms such as bi-tone or multi-tone signals (fundamental tone at rated amplitude plus one or N superimposed harmonic tones) at MV or HV. However, these tests require quite complex and expensive setups both from the generation and reference measurement chain points of view.

This paper aims to find a tradeoff between complex and expensive test procedures and simpler, but inaccurate low voltage ones.

Authors have already presented SINDICOMP [6], a compensation procedure of the IT non-linearity errors at the first harmonics. Starting from the SINDICOMP results, an approach has been then worked out which allows the construction of an approximated frequency response up to the first frequency resonance by means of two measurement steps involving only sine waves, which consists of: i) a measurement performed at rated voltage and rated frequency, and ii) a low voltage frequency sweep [7]. An approximated frequency response up to the first resonance is then reconstructed. Differently from [6] this procedure can be easily carried out by making use of generation and measurement setups already available in ITs calibration laboratories.

In this paper, a new and simpler, but accurate approach is proposed, which is based on the identification of a suitable fitting curve, always involving only a 50 Hz measurement at rated voltage and a frequency response measured at quite low voltage. Differently from [7], this new approach provides great results also performing the

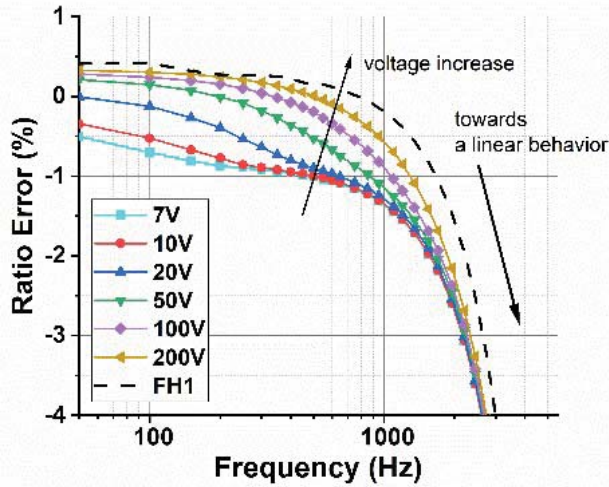

Fig. 1: Ratio errors frequency behavior obtained with various low voltage amplitudes and FH1 response (reference frequency response measured at rated voltage plus harmonic)

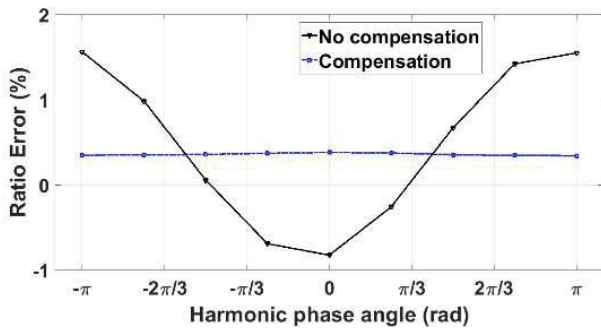

Fig. 2 Ratio error associated with the applied third harmonic versus its phase displacement without and with the compensation method SINDICOMP

low voltage frequency sweep at very low voltage amplitude (i.e. 7 V).

After preliminary consideration in section II, a detailed description of the proposed method is given in section III, in section VI measurement procedure and setup are briefly described. Experimental results, obtained from application of the method to a commercial MV VT, as well as their validation are presented in section V and at last, section VI draws the conclusions.

II. VT NON LINEARITY-PRELIMINARY CONSIDERATIONS

One of the limit of involving conventional inductive VTs in power grid frequency applications, is the non-linearity introduced by their iron-core. Two main consequences of such a non-linearity are briefly discussed in the following. The first one can be observed by comparing the ratio error frequency behavior measured under increasing applied low voltage amplitudes (tens to

some hundreds of volts (Fig. 1) and the behavior obtained with a fundamental tone at rated voltage with a superimposed harmonic frequency sweep (Fig. 1, FH1 curve). When the VT is supplied at low voltage, the magnetization of the iron core is low compared with the rated operating point and such are the iron losses, which depend on the supply voltage and frequency. Iron core effects can be introduced in a common circuitual model of a transformer by selecting, for each supply frequency, a different value of the magnetization inductance and of the resistance that emulates the actual losses. With the increase of the frequency, the effect of the stray capacitances among turns and between windings and ground starts to predominate on the non-linear effects, as shown in Fig. 1 where, beyond a certain frequency, the behavior of the ratio error can be considered independent from the supply voltage. The second consequence is visible up to the first harmonics when the rated supply voltage is applied. We can note that the ratio error obtained by applying the rated 50 Hz supply voltage with a superimposed third harmonic as a function of the phase angle with respect to the fundamental one shows a sinusoidal behavior (see Fig 2). This effect is due to the combination of the harmonic applied to the input of the VT and the harmonic generated by the fundamental tone because of the B-H curve non-linearity of the VT. By SINDICOMP method [6], **Errore. L'origine riferimento non è stata trovata.** such a non-linearity can be quite satisfactorily compensated at the rated supply voltage as shown in Fig 2.

III. APPROXIMATED FREQUENCY RESPONSE

To build the approximated VT frequency response, three different elements are needed: the VT error at power frequency and rated amplitude $\varepsilon_{50 \text{ Hz}}$, the low voltage frequency response $\varepsilon_{LV}(f)$ and the derivative absolute value D of the low voltage frequency response.

A specific frequency range has to be identified, which ranges from f_{Dlim} , that is selected by the study of D curve, up to f_s that depends on the VT first resonance frequency. Previous experimental tests on MV VTs with primary voltage from $10/\sqrt{3}$ kV to 15 kV suggest that the derivative absolute value D of the low voltage frequency response has a repetitive behavior. In particular, after a first quite flat part, the curve begins to increase, because of the increasing weight of the stray capacitances among windings and ground (linear effects) on the frequency dependence of VT errors. Thus, f_{Dlim} is identified as the frequency starting from which the linear effects are predominant over the non-linear ones. This means that for frequencies higher than f_{Dlim} , VT frequency errors can be assumed independent of the primary voltage amplitude. According to previous tests carried out [7] the best value of D_{lim} can be selected in the (0.1 to 0.2) $0.01 \cdot \text{Hz}^{-1}$ range. As regard f_s , it has to be chosen 1 kHz before the first resonance peak.

Consequently, in the selected frequency region from f_{Dlim} to f_s the VT can be considered linear and its frequency

response independent from the applied primary voltage up to the rated one.

The proposed method requires fitting the measured low frequency response values to the following function:

$$y = \frac{\sqrt{(\omega L)^2 + R^2}}{\sqrt{\left(1 - (\omega/\omega_r)^2\right)^2 + \left(\omega/\omega_r^2 \cdot R/L\right)^2}} \quad (1)$$

where:

- ω is the angular frequency,
- ω_r is the angular frequency of the first resonance of the VT frequency response, evaluated from the experimental data;
- R and L are the fit parameters.

The structure of this function is clearly equivalent to the function that describes the impedance frequency behavior of a circuit simply constituted by the parallel connection of an inductor and a capacitor.

The fit function has to be improved to take into account the actual VT response at the lowest frequency, where the VT non-linearities are predominant. This is done by adding an offset correction ε_{OFS} which is computed as the difference between and the error measured by applying the rated primary voltage at 50 Hz, $\varepsilon_{50\text{ Hz}}$, and the value of the ratio error estimated at 50 Hz by the fitting procedure:

$$\varepsilon_{OFS} = \varepsilon_{50\text{ Hz}} - \varepsilon_{FIT}(50\text{ Hz}) \quad (2)$$

The final VT approximated frequency response is then assumed equal to the $\varepsilon_{FIT}(f) + \varepsilon_{OFS}$ curve from power frequency up to a frequency f_L . The f_L value is chosen as the frequency corresponding to the minimum absolute difference between the low voltage measured errors $\varepsilon_{LV}(f)$ and the curve $\varepsilon_{FIT}(f) + \varepsilon_{OFS}$; for frequencies higher than f_L , the $\varepsilon_{LV}(f)$ response is assumed.

A graphical representation of the fitting procedure for the identification of the VT frequency response is shown in Fig. 4, where the involved ratio error curves versus frequency are shown.

IV. MEASUREMENT PROCEDURE AND SETUP

A. Measurement Procedure

According to the method above described two measurement steps are needed and both involve only sine wave generation.

The first step is the determination of the VT ratio and phase errors at 50 Hz, according to standard [8]. It requires the generation of a sinusoidal voltage at power frequency with amplitude from 80% to 120% of VT under test primary rated voltage.

The second step consists in a frequency sweep from power frequency up to the first resonance frequency performed at low voltage, e.g. 7 V. As the output, for each generated frequency the ratio errors is evaluated according to (3)

$$\varepsilon_{h\%} = \frac{k_r V_{s,h} - V_{p,h}}{V_{p,h}} \cdot 100 \quad (3)$$

where:

- $k_r = \frac{V_{p,r}}{V_{s,r}}$ is the rated transformation ratio ($V_{p,r}$ and $V_{s,r}$ are the rated primary and secondary voltages)
- $V_{p,h}$ and $V_{s,h}$ are the root mean square (rms) values of the primary and secondary h -order harmonic voltage.

B. Measurement Setup

Two measurement setups with different generation capabilities are used for step 1 and step 2, respectively.

For step 1, the VT characterization is carried out with the measurement setup shown in Fig. 3. The signal generation is obtained by means of an Arbitrary Waveform Generator (AWG), the NI PXI 5421, with 16 bit, variable output gain, $\pm 12\text{ V}$ output range, 200 MHz maximum sampling rate, 256 MB of onboard memory. It is inserted in a PXI chassis, and the 10 MHz PXI clock is used as reference clock for its high - resolution Phase Locked Loop circuitry. The voltage waveform generated by the AWG is amplified by a Trek high-voltage power amplifier (30 kV_{peak}, 20 mA_{peak}) with wide bandwidth high slew rate and low noise. Applied voltage reference values are obtained by means of a 30 kV wideband reference divider designed, built and characterized at INRIM [9],[10].

For step 2, low voltage frequency sweep is performing using a Fluke 5500A calibrator controlled by remote and no reference sensor is needed since the generated low voltage amplitude is always compliant with the acquisition system.

For both the measurement setup, the acquisition system is obtained through NI cDAQ chassis with four different acquisition modules (from $\pm 500\text{ mV}$ up to $\pm 425\text{ V}$, 24 bit, 50 kHz)

The VT primary and secondary voltage are acquired with a sampling frequency $f_s = 50\text{ kHz}$, the time window chosen is 1 s and 10 iterations are executed for each test.

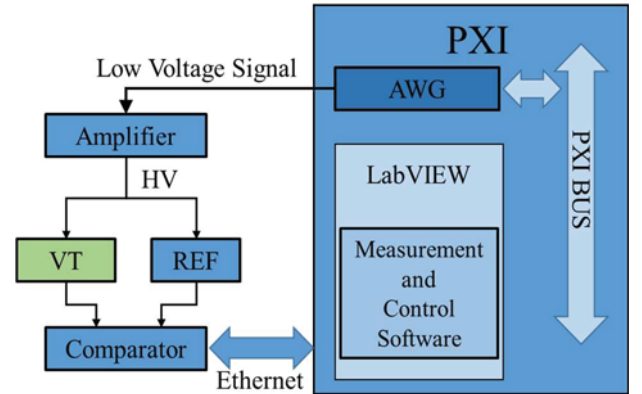

Fig. 3 Block diagram of the setup for step 1 VT characterization

Since there is no synchronization between generation and acquisition, Interpolate Discrete Fourier Transform (IpDFT) is performed on the acquired samples to measure voltage phasors.

V. EXPERIMENTAL RESULTS

As a first application of the method, characterization of a commercial VT is performed using the proposed procedure and preliminary results and their validation are shown in this section for the ratio error. The results are validated by comparison with the reference frequency response obtained by making use of the INRIM reference system for frequency characterization of MV VTs, by applying the FH1 procedure as described in [7].

A. Device under test

The considered VT for this analysis is a commercial resin insulated VT for MV measurement application. The VT main features are summarized below:

- 1) rated primary voltage $20/\sqrt{3}$ kV,
- 2) rated secondary voltage $100/\sqrt{3}$ V,
- 3) rated frequency 50 Hz,
- 4) rated burden 50 VA,
- 5) accuracy class 0.5.

B. Reference test: FH1

INRIM reference test for frequency characterization of VT involves the generation of a distorted voltage signal at MV voltage. The applied voltage is composed of a fundamental tone plus one harmonic tone (FH1), more specifically, the fundamental tone has an amplitude in the range 80% to 120% of VT primary rated voltage, whereas the harmonic tone amplitude is 1% of the fundamental tone. The fundamental tone frequency is fixed at 50 Hz; the harmonic frequency varies from 50 Hz up to 10 kHz. Between the fundamental and the harmonic tone, several phase delays in the range $\pm\pi$ rad can be imposed.

C. Evaluation of the Approximated Frequency Response

Step 1 is performed by applying 100% of rated primary value at 50 Hz with zero burden.

As regard step 2, frequency sweep is carried out at 7 V from 50 Hz up to 200th harmonic and, as for step 1 no burden is employed.

For each frequency test and for each generated voltage amplitude, ratio error is evaluated.

By the study of D , f_{Dim} is fixed to 2.2 kHz while since the first resonance is found at $f_r=5.9$ kHz, f_s is set to 5 kHz. In the identified frequency region, the best fitting curve is achieved setting the parameter R and L at 1.2 Ω and 0.2 mH, respectively. In Fig 5 the frequency response at 7 V and its fitting curve are shown.

The fitting curve (red line in Fig 5) is then shifted by adding an offset of 1.60% to reach the value $\epsilon_{50Hz}=0.41\%$ measured according to step 1.

Lastly, the absolute value of the frequency deviation between the shifted fitting curve and the response at 7 V is evaluated and the minimum value is found at $f=4400$ Hz so from this frequency point, the 7 V ratio error response is assumed.

D. Fitting Procedure Validation

The ratio error frequency response obtained by the low voltage frequency sweep and the one by the proposed method are compared to the reference response FH1 and their deviations are shown in Fig 6. Performing the fitting procedure allows to reduce drastically the ratio error difference with respect to the reference test, for example at 400 Hz the deviation reduces from 1.2% to 0.07%, at 2 kHz from 1.1% to 0.02% and, finally, at 4 kHz from 0.92% to 0.17%.

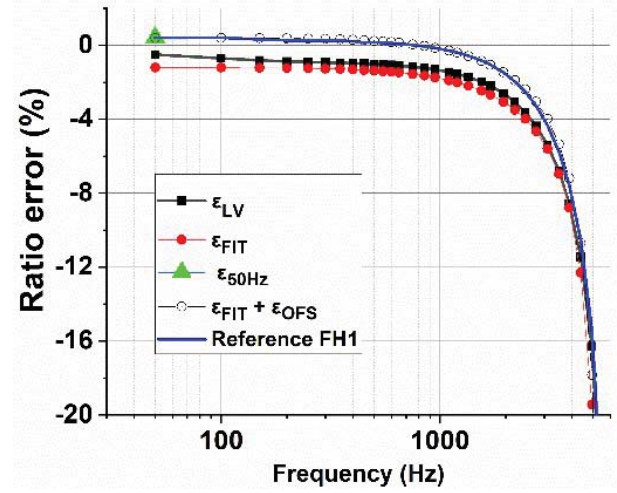

Fig. 4 Graphical description of the fitting procedure for the identification of the VT frequency response

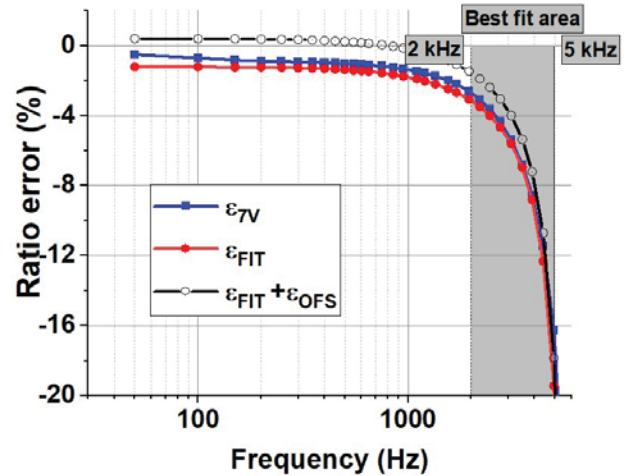

Fig 5 Comparison among the ratio error measured with 7 V frequency sweep, the fitted error and the proposed approximated response

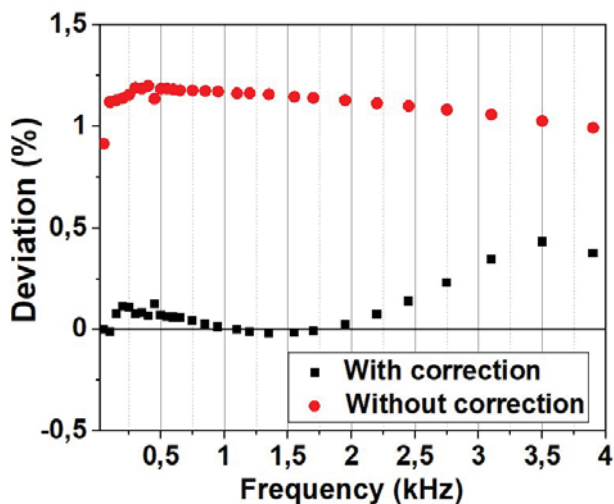

Fig. 6 Ratio error deviation between low voltage response and FHI reference test (red dots) and between approximated response and FHI reference test (black squares)

VI. CONCLUSION

A simplified procedure for the measurement of the frequency response of the voltage instrument has been presented. The developed procedure aims to be a tradeoff between complex and strict test procedures and simple but inaccurate ones. The proposed method is applied for the frequency characterization of a commercial MV VT and is validated by comparison with results obtained at MV by the INRIM reference method. Preliminary results show that even with frequency sweeps performed at very low voltage (7 V), deviations between reference and simplified procedure can be reduced of one order of magnitude. The presented method is still in experimental stage. Future work will include a similar approach for phase error approximation and applications to VTs of different manufactures and sizes.

ACKNOWLEDGMENT

The result here presented are developed in the framework of the 19NRM05 IT4PQ funded by the EMPIR program (European Metrology Program for Innovation and Research) co-financed by the Participating States and the European Union's Horizons 2020 research program.

REFERENCES

[1] R. Stiegler, J. Meyer, J. Kilter and S. Konzelmann, "Assessment of voltage instrument transformers accuracy for harmonic measurements in transmission systems," 2016

- 17th International Conference on Harmonics and Quality of Power (ICHQP), Belo Horizonte, 2016, pp. 152-157.
- [2] M. Faifer, C. Laurano, R. Ottoboni, S. Toscani and M. Zanoni, "Harmonic Distortion Compensation in Voltage Transformers for Improved Power Quality Measurements," in press on IEEE Transactions on Instrumentation and Measurement.
- [3] M. Faifer, C. Laurano, R. Ottoboni, S. Toscani and M. Zanoni, G. Crotti, D. Giordano, L. Barbieri, M. Gondola, P. Mazza, "Overcoming Frequency Response Measurements of Voltage Transformers: An Approach Based on Quasi-Sinusoidal Volterra Models," in IEEE Transactions on Instrumentation and Measurement, vol. 68, no. 8, pp. 2800-2807, Aug. 2019
- [4] A. Cataliotti, D. Di Cara, A. E. Emanuel and S. Nuccio, "A Novel Approach to Current Transformer Characterization in the Presence of Harmonic Distortion," in IEEE Transactions on Instrumentation and Measurement, vol. 58, no. 5, pp. 1446-1453, May 2009
- [5] A. J. Collin, A. D. Femine, D. Gallo, R. Langella and M. Luiso, "Compensation of Current Transformers' Nonlinearities by Tensor Linearization," in press on IEEE Transactions on Instrumentation and Measurement, 68 (10), art. No. 8713410, pp. 3841-3849
- [6] A. Cataliotti, V. Cosentino, G. Crotti, A. Delle Femine, D. Di Cara, D. Gallo, D. Giordano, C. Landi, M. Luiso, M. Modarres, G. Tinè "Compensation of Nonlinearity of Voltage and Current Instrument Transformers," in IEEE Transactions on Instrumentation and Measurement, Vol. 68, no. 5, 2019, pp. 1322, 1332.
- [7] P.S. Letizia, G. Crotti, D. Giordano, A. Delle Femine, D. Gallo, C. Landi, M. Luiso, "Low Cost Procedure for Frequency Characterization of Voltage Instrument Transformers," Proc. of 2019 IEEE International Instrumentation and Measurement Technology Conference
- [8] IEC 61869-3 (2012) Instrument transformers - Part 2: Additional Requirements for Inductive Voltage Transformers.
- [9] G. Crotti, D. Gallo, D. Giordano, C. Landi, M. Luiso, M. Modarres, M. Zucca, Frequency Compliance of MV Voltage Sensors for Smart Grid Application (2017) IEEE Sensors Journal, 17 (23), art. no. 7976280, pp. 7621-7629
- [10] A. Delle Femine, D. Gallo, D. Giordano, C. Landi, M. Luiso, R. Visconte, A Set-up for Static and Dynamic Characterization of Voltage and Current Transducers used in Railway Application (2018) Journal of Physics: Conference Series, 1065 (5), art. no. 052019