

Results of a Feasibility Study of a Prognostic System for Electro-Hydraulic Flight Control Actuators

Original

Results of a Feasibility Study of a Prognostic System for Electro-Hydraulic Flight Control Actuators / Autin, Sylvain; De Martin, Andrea; Jacazio, Giovanni; Socheleau, Jérôme; Vachtsevanos, George. - In: INTERNATIONAL JOURNAL OF PROGNOSTICS AND HEALTH MANAGEMENT. - ISSN 2153-2648. - ELETTRONICO. - 12:3(2021).
[10.36001/ijphm.2021.v12i3.2935]

Availability:

This version is available at: 11583/2884585 since: 2021-04-28T12:06:49Z

Publisher:

PHM Society

Published

DOI:10.36001/ijphm.2021.v12i3.2935

Terms of use:

This article is made available under terms and conditions as specified in the corresponding bibliographic description in the repository

Publisher copyright

default_article_editorial [DA NON USARE]

-

(Article begins on next page)

Results of a Feasibility Study of a Prognostic System for Electro-Hydraulic Flight Control Actuators

Sylvain Autin¹, Andrea De Martin^{2*}, Giovanni Jacazio³, Jérôme Socheleau⁴, and George Vachtsevanos⁵

1,4 Collins Aerospace, Saint-Ouen l'Aumône, 95310, France

sylvain.autin@collins.com

jerome.socheleau@collins.com

2,3 Politecnico di Torino – Department of Mechanical and Aerospace Engineering, Torino, 10129, Italy

andrea.demartin@polito.it

giovanni.jacazio@polito.it

5 Georgia Institute of Technology, Atlanta, GA, 30332, USA

gju@ece.gatech.edu

ABSTRACT

Electro-Hydraulic Servo-Actuators (EHSA) are currently the most used actuation technology for primary flight control systems of civil and military aircrafts. Although some alternatives have emerged in the last decade, such as electro-mechanical or electro-hydrostatic solutions, electro-hydraulic systems are still considered the most effective technology in flight-critical application of new commercial aircrafts. Moreover, the vast majority of aircraft currently in service are equipped with this technology. Considering the number of actuators typically employed in a primary flight control system and the expected service life of a commercial aircraft, the development of an effective PHM system could provide significant benefits to fleet operators and aircraft maintenance. This paper presents the results of a feasibility study of such a system for electro-hydraulic actuators used in fly-by-wire primary flight control systems, considering the actuator of a wide body commercial aircraft as use case. Aim of the research is the implementation of a PHM system without the addition of dedicated sensors, solution which would allow for the application of the proposed prognostic solution on both new and existing platforms. This paper describes the methodology and the results of the feasibility study through simulation and experimental activities, which shows how the novel PHM technologies proposed for a PHM system for the EHSAs of primary flight control actuators can

allow the migration from scheduled to condition-based maintenance.

1. INTRODUCTION

Flight control systems and their associated flight control servo-actuators are one of the safety critical aircraft systems and represent one of the most significant cause of operation disruption in both civil and military aircrafts. The development of an effective Prognostics and Health Management framework for primary flight control actuators, possibly deployable within an Integrated Vehicle Health Monitoring (IVHM) system could lead to a significant technological advancement providing several benefits both at the aircraft and at the fleet level. Successful development of this technology would allow to sensibly improve the aircraft operational reliability and dispatch ability by avoiding unpredicted vehicle on-ground immobilization, and hence reducing, or possibly removing, the additional costs associated with takeoff delays or cancellations, re-routing or in-flight turn back. Moreover, it would allow a reduction of the direct maintenance costs by improving the management of spare parts, maintenance logistics and simplifying the troubleshooting operations. The impact of the costs associated with unnecessary or unpredicted maintenance and with the effects of flight disruption is difficult to precisely evaluate and is heavily dependent on the aircraft type, its usage, the maintenance policies of the airliner and the contingent situation related with the failure occurrence. According to IATA projections, the expected global spending in 2020 for maintenance, repair and overhaul is US\$ 65 billion (International Air Transport Association (IATA),

Sylvain Autin et al. This is an open-access article distributed under the terms of the Creative Commons Attribution 3.0 United States License, which permits unrestricted use, distribution, and reproduction in any medium, provided the original author and source are credited.

<https://doi.org/10.36001/IJPHM.2021.v12i3.2935>

2011), while a recent study on integrated disruption management and flight planning shows that suitable planning can mitigate the effects of flight disruptions and lead to about 6% cost saving for the airline (Marla, Lavanya & Vaaben, Bo & Barnhart, 2012). Although the spending for flight control actuators is expected to be just a fraction of the total, the contribution gained from the introduction of an effective health monitoring system for aircraft flight control actuators will still provide significant cost savings. The development of PHM frameworks for primary flight control systems is still a rather unexplored subject, despite representing one of the critical aircraft systems. This can be mainly attributed to low availability of relevant data, major difficulties in modeling and testing and generally a lack of sound understanding of the failure mechanisms affecting the most common architectures employing Electro-Hydraulic Servo Actuators. Most of the available literature revolves around Electro-Mechanical Actuators, which application to primary flight controls is however limited only to Unmanned Aerial Vehicles (UAVs) by some unresolved technological barriers, including the sensitivity to certain single point of failures that can lead to mechanical jams. For these reasons, Electro-Hydraulic Servo Actuators are still the most used solution for primary flight control systems of new commercial aircraft, while representing the vast majority of the actuation systems of the vehicles already in service and expected to keep operating in the next years. As such, the definition of an effective Prognostics and Health Management system for EHSA would be an attractive goal to improve fleet management for both new and legacy aircrafts. Literature on prognostics for EHSA is so far extremely limited, and mostly focused on a few single faults scenarios; in (Byington et al., 2004), authors presented one of the few research papers focused on the hydraulic actuators for aviation. The authors examine the possibility of developing a PHM system for the F/A-18 stabilizer Electro-Hydraulic Servo-Valves (EHSVs). The data-driven approach developed uses neural network error-tracking techniques, along with fuzzy logic classifiers, Kalman filter state predictors, and feature fusion strategies. In (Guo & Sui, 2019) authors proposed a new resampling scheme based on Hellinger's distance and verified their results on accelerated fatigue tests on a few structural components of the actuator, while a fault diagnosis scheme for electro-hydrostatic actuation system is briefly described in (Chen et al., 2019). The physical and operational complexities typically encountered in critical EHSA systems necessitate new and innovative technologies whose underpinnings take advantage of physics of failure mechanisms, first principle models, novel Condition Indicator (CI) extraction and selection techniques, rigorous diagnostic and prognostic algorithms accompanied by appropriate performance metrics, such as Relative Accuracy and Prognostic Horizon, and extensive seeded fault testing procedures. Each of these tasks come with a set of issues which are not easily resolved a priori and might hinder the development of the PHM system. The feasibility study

described in this paper is aimed at evaluating how an innovative fault diagnosis and failure prognosis framework for EHSAs can successfully be developed by integrating mathematically rigorous and validated signal processing, feature extraction, diagnostic and prognostic algorithms with novel uncertainty representation and management tools in a platform that is computationally efficient and ready to be transitioned on-board an aircraft. The feasibility study was performed taking as a use case the EHSA of a flight control actuator of a commercial aircraft in revenue service whose characteristics and performance are well known and documented. Starting from previously published work from same authors on hydraulic components on a variety of aerospace applications (Autin et al., 2018; Dalla Vedova et al., 2010; Nesci et al., 2020), an extensive failure modes identification and analysis task was carried out to focus on critical/severe, frequent and testable failure modes, such as demagnetization of the servo-valve torque motor, backlash of the servo-valve internal feedback spring, wear of the internal seals of the hydraulic actuator. A high-fidelity mathematical model was developed which accepts the injection and progression of faults described by a physics-based model of the fault development as a function of usage, time, operational and environmental conditions. Data relevant to more than three hundred flights of ten aircrafts were generated with the EHSA in healthy and progressively faulty conditions, with the aim of defining a novel set of features without adding dedicated sensors. Flights along different routes with different and varying environmental and operational conditions were considered, and the faults resulting as most critical from a FMECA analysis were addressed, supported by seeded fault data provided by a dedicated test-bench. The paper is organized as follows. At first, the methodology employed to perform the feasibility analysis is detailed and justified. Hence, the case study is presented in detail, accompanied by a failure analysis investigating the most significant degradation modes. Then, the health monitoring strategy and framework are introduced. Results of feature selection activities are then presented, providing conclusions drawn from simulation activities and experimental effort. Finally, each function of the PHM algorithm is then defined and their performance assessed.

2. APPROACH TO THE DESIGN OF A NOVEL PHM SYSTEM

The theme of designing a novel PHM system and the study its feasibility have been tackled using the approach described in Figure 1 (Autin et al., 2018). The first step is the definition of the use case, which is an in-service Electro-Hydraulic Servo Actuator for primary flight control systems. Hence, an in-depth failure analysis over the chosen case study is performed and used to select the most prominent failure modes to be inserted as input to the definition of a high-fidelity model of the EHSA under analysis, completed with fault evolution models. Real operational data made available by the industrial partners are then used to recreate a shortened

pattern of loads and commands representative of the real-field operational scenario. These realistic conditions are then fed to the high-fidelity model of the EHSA to perform flight simulations in healthy and faulty conditions. The flight data obtained from these simulations are the basis on which the PHM system is developed and evaluated, since they are used to build a large data-base of signals with the aim of selecting the proper set of features representative of the health status of the device. The PHM system development follows the guidelines suggested in (Vachtsevanos et al., 2007) using as inputs the results of the use case definition process, the failure analysis and the simulated flight data. Laboratory tests are then performed by introducing or simulating the effects of a selected number of degradations of different severity on a real actuator, and the results used to validate the usefulness of the features defined through simulated data. The PHM system is then designed step-by-step. At first the post-processing techniques used for the feature extraction are defined, hence the fault diagnosis methodology and finally the failure prognosis algorithm. Hence its performances are assessed according to appropriate metrics.

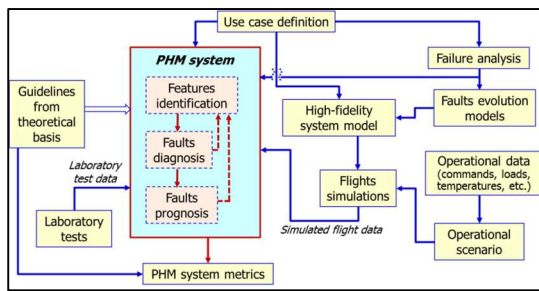

Figure 1: Research flow block diagram

3. THE ACTUATION SYSTEM

The actuation system under analysis is a real primary flight-control architecture employed on a class of currently in-service aircrafts. Depicted in Figure 2, the aerodynamic surface is controlled by the combined effect of two Electro-Hydraulic Servo Actuators, governed by the Flight Control Computers according to the active-stand-by configuration. According to this architecture, only one of the two actuators is used to actively control the position of the tab, while the second actuator is put in by-pass mode and provides a damping effect on the dynamics of the flight control, while at the same time ensuring the appropriate level of safety through the redundancy of the actuation systems. At the beginning of each flight, one actuator is put in active mode, while the other one is kept in by-pass, and is activated only in case of emergency. The roles of the two hydraulic devices are periodically exchanged. Each Electro-Hydraulic Servo actuator follows the schematics provided in Figure 3 (Autin et al., 2018). The hydraulic circuit is made of an electro-hydraulic servovalve, a mode valve operated by a two-position solenoid valve, an accumulator and the hydraulic

cylinder. The servo-valve is of the jet pipe type and it is made up of two stages with the first stage receiving the current command as the input and using the torque motor in order to move the jet projector thus creating a pressure differential between the two sides of the second stage spool, which controls the flow to the hydraulic actuator. The control logic uses a linear position transducer (LVDT) as the feedback sensor to close the position control loop. The EHSA is dual electrical interfacing with two independent electrical lanes. When in the active mode, the solenoid valve is energized and a pressure pilot signal for the mode valve is generated. The spool of the mode valve hence moves and connects the servo-valve control ports to the actuator ports, thereby allowing the actuator to move in response to the electrical signals received by the servo-valve. To achieve the stand-by conditions, the solenoid valve is instead de-energized. The hydraulic lines connected to the servo-valve control ports are hence blocked and the hydraulic fluid passing from one chamber to the other is forced through a damping orifice, providing a resistant force on the actuation system proportional to the actuator velocity. This function avoids the insurgence of possible aero elastic instability (flutter) in case of failure of both EHSAs connected to the same flight control surface. In addition to the linear position transducer on the actuator, each Electro-Hydraulic Servo Actuator is equipped with a number of other sensors, namely: LVDTs measuring the linear position of the servo-valve spool, a differential pressure sensor mounted across the actuators' chambers and another LVDT measuring the position of the mode valve spool. The signals provided by these sensors are used in combination with the control signals to perform the continuous monitoring functions for detection of potentially flight critical failures (C-BIT) and to perform pre-flight checks (P-BIT) to ensure that no failure exists before flight in the existent flight control actuators. The signals generated by the whole array of sensors, together with the servo-valve and solenoid valve currents are considered as available to be exploited by a PHM system and are the foundational basis on which this preliminary study is built.

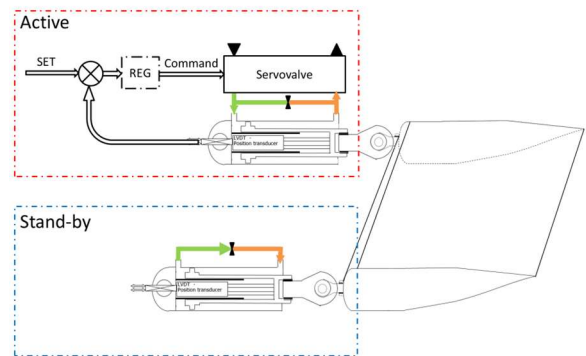

Figure 2. Active-stand-by architecture

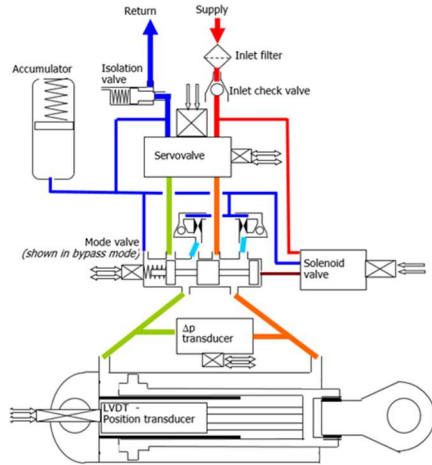

Figure 3. EHSA reference architecture

4. FAILURE ANALYSIS

The first step of the proposed feasibility study is the analysis of the failure modes possibly affecting the actuation system. This operation is critical to any preliminary study of PHM framework and is used to assess which failure modes need to be considered by the Health Monitoring system, which must be prioritized in the study and to anticipate the interaction between two or more failure modes. The tool used to perform this analysis is the Failure Modes and Effects Criticality Analysis (FMECA) in which all possible failures, their criticality and probability of occurrence are considered and compared accordingly (Vachtsevanos et al., 2007). Each of the investigated failure modes described in this section has been prioritized according to the results of the FMECA presented in (Autin et al., 2018).

4.1. Servovalve

The servovalve of the actuation system under analysis belongs to the jet-pipe type and its schematics is reported in Figure 4. In the first stage the torque motor imposes an electro-magnetic torque over the jet-pipe by circulating an electric current of controlled intensity within its windings. The applied torque tends to rotate the jet-pipe, connected to the supply pressure, around its hinge point, causing the growth of a pressure differential between the two channels of the hydraulic amplifier. This pressure differential causes the shift of the spool in one direction, hence connecting the two actuator ports A and B with the supply port P or the tank T. The feedback spring applies then an equilibrating force on the jet-pipe, bringing it back to the neutral position and hence allowing the static equilibrium of the spool in a position different from the neutral one. Both the first and the second stage of the servovalve can be affected by a wide array of degradation modes. The most critical and most delicate component of the servovalve is probably the feedback spring and any issue possibly affecting this part translates into

uncontrolled oscillations of the spool and hence instability of the position control loop of the actuator. Two major failure modes have been recognized for the spring, which are the inception and growth of a crack and the wear at its ends due to the relative motion at its interfaces with both the jet-pipe and the spool. Another critical component is the jet-pipe, which small diameter and delicate mechanical structure makes it subject to mechanical strains and oil contamination. The two failure modes selected for the analysis are the distortion of its structure due to mechanical actions and the partial occlusion of its channel due to contaminated fluid. The final failure mode considered for the servovalve is the degradation of the torque motor performances due to the ageing of its permanent magnets.

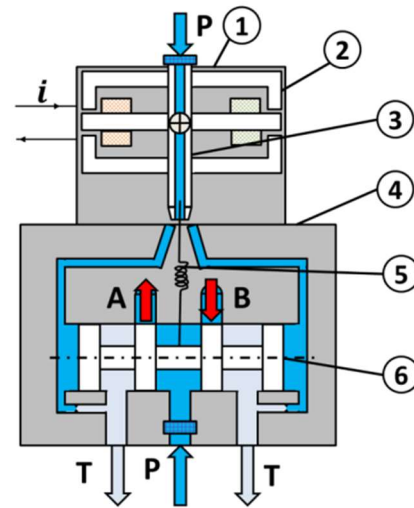

Figure 4. Schematics of a jet-pipe Servovalve. (1) First stage. (2) Torque motor. (3) Jet-pipe. (4) Second stage. (5) Feedback spring. (6) Spool.

4.2. Hydraulic Actuator

The schematics of the hydraulic actuator in the active configuration and in by-pass mode are reported in Figure 5-(a) and Figure 5-(b). The internal seals are responsible for the hydraulic separation between the two chambers of the actuators. Wear of this component is one of the most common degradation modes encountered on in-service actuators, and is responsible for significant performance losses. Another well documented failure mode is the wear in the spherical joints of the rod-ends due to the relative rotation between the actuator's rod and the supports of the aerodynamic surface. Bad lubrication conditions and prolonged usage are the main responsible for this failure mode, which generally lead to the loss of positioning accuracy and possibly fluttering of the aerodynamic surface, albeit of small amplitude. The other

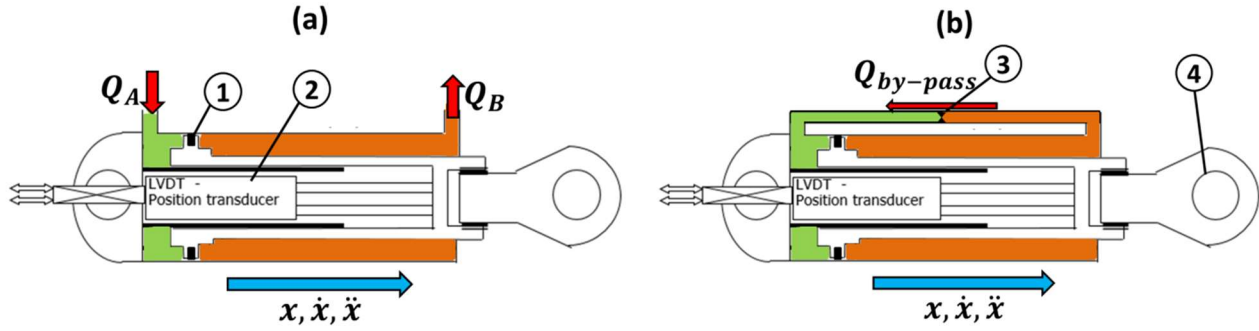

Figure 5. The hydraulic actuator. (a) Active (b) Stand-by. (1) Seals. (2) LVDT. (3) By-pass orifice. (4) Rod end

two failure modes considered in this paper are the loss of sensitivity in the LVDT transducer, possibly due to short circuits in its windings, and the occlusion of the by-pass orifice due to contaminants such as seals debris. Variations of the LVDT sensitivity can be extremely dangerous due to the relevance of this particular sensor within the position control loop, while the partial occlusion of the by-pass channel can lead to significant changes in the damping properties of the actuation system and to sensible decreases of the maximum achievable speed.

5. HEALTH MONITORING STRATEGY

Flight Control actuators, and especially those used in primary flight controls, represent an interesting challenge for Health Monitoring systems; these devices are classified as safety critical, behave following command patterns difficult to predict a priori and their actuation time is limited through most of the mission. These functional characteristics generate a few issues that must be considered when designing a new prognostics system. The first and most prominent one is the uncertainty associated with the features computed from signals coming from in-flight measures. The operational conditions of the actuators can be widely varying, while the aerodynamic load pattern is often unpredictable due to gusts and turbulence. The pilots commands are moreover almost impossible to forecast, since they are heavily influenced by the pilot experience and capability, contingent flight situations and chosen route. The uncertainty associated with these unknown behaviors is further amplified by the difficulties in obtaining localized measures of important physical quantities. The number of sensors available on an in-service actuator is relatively low, and several measures which would be instrumental to the PHM algorithms are usually lacking (i.e. aerodynamic load, flow rates etc.). A possible solution to these issues is the use of dedicated pre or post flight checks based on short, repeatable sequences of commands studied to enhance the effects of a selected number of faults over the available signals (Dalla Vedova et al., 2010; De Martin et al., 2017). This approach has the significant advantage of extracting the features in a semi-

controlled environment, (negligible external load, pre-defined commands). At the same time, a significant drawback is represented by the time scarcity of the obtainable data, since only one acquisition per mission is possible. This makes it difficult to perform an efficient failure prognosis and does not allow to address degradations which last less than the duration of a single mission. As such, data collected through on-ground checks are suitable to help the fault classification routines but not to for long-term prognosis. We opted to use a Health Monitoring strategy based on both data collection methods to exploit the benefits of each possible option. Fault detection and prognosis are hence tackled through in-flight data, while fault classification is pursued through the less-noisy signals obtained during pre-flight checks. The command sequence used for the on-ground acquisition is reported in Figure 6 (Autin et al., 2018). It is made of a sinusoid, a step and a ramp which overall lasts less than 2.5 s. The ground tests are performed with one actuator active and the other in stand-by mode. Movements are then repeated reversing the operating conditions for the two actuators. Since two electrical lanes control the servo-valve and the solenoid valve, each ground test is performed twice, each time with one of the two electrical lanes active Experimental dataset.

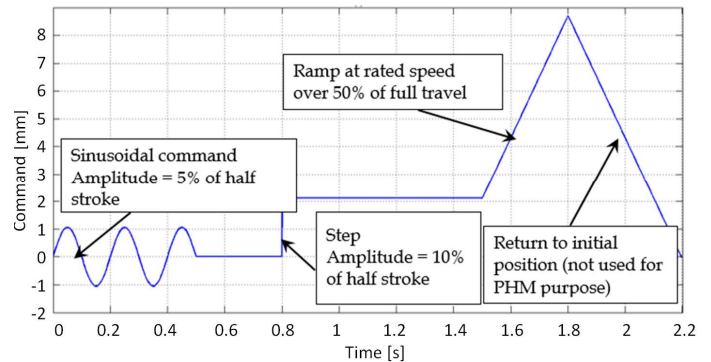

Figure 6: Command sequence for on-ground tests

6. PHM SYSTEM ARCHITECTURE

The structure of the proposed Prognostics and Health Management system is depicted in Figure 7 (Autin et al., 2018) and can be roughly divided in three major sub-functions; feature extraction, fault diagnosis and prognosis. During the feature extraction step the system will be able to filter the signals and extract meaningful health condition indexes by combining the measures coming from the actuators sensors. Features are hence sent to the fault diagnosis module (or reasoner), which collects data and performs the anomaly detection and fault classification. Finally, the output are sent to the prognostic routines and used to estimate the Remaining Useful Life of the device. The PHM framework hereby presented is though as working in parallel with the monitoring procedures currently employed on servo-actuators, which purpose is to determine if a failure is present or not within the actuation system. These procedures provide three different functions, “C-BIT”, “P-BIT” and “I-BIT”. “C-BIT” routines are continuously performed during flight to detect the occurrence of failures which have the potential to be safety critical for the entire aircraft. “P-BIT” are specific checks performed during the pre-flight operations to detect dormant failures which might affect the components used to put in safe mode the actuator whether a failure occurs. Finally, the “I-BIT” are used to check the conditions of a few selected components. Independently from the type of procedure, traditional Health Monitoring is not used to observe a degradation of the health status of the actuator’s components, but only to ensure that the safety requirements are met before and during missions. Moreover, it is not used to isolate and identify faults or failures. On the other hand, the PHM system is not used for safety reasons, but only for maintenance and strategic purposes. Despite the advancements in the fields, prognostics algorithms are still far from being a mature technology and are so far not suitable to successfully pass the rigorous certification procedures required for safety-critical software.

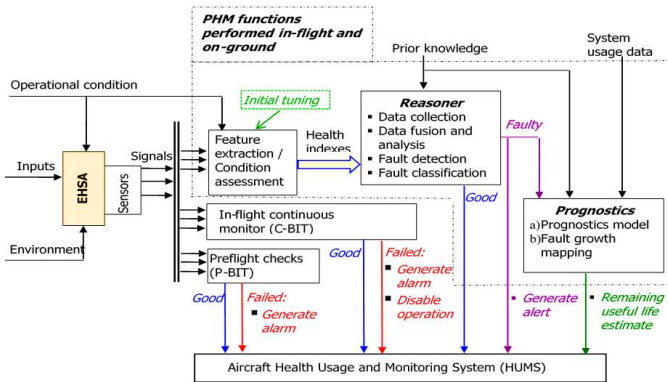

Figure 7: Architecture of the Health Monitoring system

The purpose of the PHM system discussed in this paper is instead to detect an on-going degradation in the actuator components, isolate and identify the nature and the origin of the fault and finally provide a forecast of the fault evolution with the aim of increasing the aircraft availability and provide additional information to the platform holders. The prognostic framework takes advantage of nonlinear process (fault / degradation) model, one for each examined failure modes, a Bayesian estimation method using particle filtering and real-time measurements (Orchard & Vachtsevanos, 2009). Prognosis through particle filtering is achieved by performing two sequential steps, prediction and filtering. Prediction uses both the knowledge of the previous state estimate and the process model to generate the a priori estimate of the state probability density functions (pdfs) for the next time instant,

$$\begin{aligned} p(x_{0:t}|y_{1:t-1}) \\ = \int p(x_t|y_{t-1})p(x_{0:t-1}|y_{1:t-1}) dx_{0:t-1} \end{aligned} \quad (1)$$

This expression usually does not have an analytical solution, requiring Sequential Monte Carlo algorithms to be solved in real-time with efficient sampling strategies (Roemer et al., 2011). Particle filtering approximates the state pdf using samples or “particles” having associated discrete probability masses (often called “weights”) as,

$$p(x_t|y_{1:t}) \approx \tilde{w}_t(x_{0:t}^i)\delta(x_{0:t} - x_{0:t}^i)dx_{0:t-1} \quad (2)$$

where $x_{0:t}^i$ is the state trajectory and $y_{1:t}$ are the measurements up to time t . The simplest implementation of this algorithm, the Sequential Importance Re-sampling (SIR) particle filter (Arulampalam et al., 2007), updates the weights using the likelihood of y_t as:

$$w_t = w_{t-1}p(y_t|x_t) \quad (3)$$

Although this traditional particle filtering technique has limitations, in particular with regards to the description of the distributions tails, and more advanced resampling schemes have been proposed (Acuña & Orchard, 2017), this technique was still deemed valid for a purely preliminary analysis, which main purpose is to assess the feasibility of a PHM system for Electro-Hydraulic Servo Actuators and provide a first benchmark to be progressively improved in further stages of the research programme. Long-term prediction of the fault evolution can be obtained by iterating the “prediction” stage, and are used to estimate the probability of failure in a system given a hazard zone that is defined via a probability density function with lower and upper bounds for the domain of the random variable, denoted as H_{lb} and H_{up} , respectively (Acuña & Orchard, 2018). As shown in Figure 8 (De Martin, Jacazio, et al., 2018), this approach makes use of degradation models that are tuned or their parameters adjusted to compute the current a priori state of the system, $p(x_t|y_{1:t-1})$, and to perform the iterative calculation that leads to the long term prediction $p(x_{t+k}|y_{1:t})$. Auto-tuned

models are required to describe and follow changes in the degradation process and to describe the process and measurement noise.

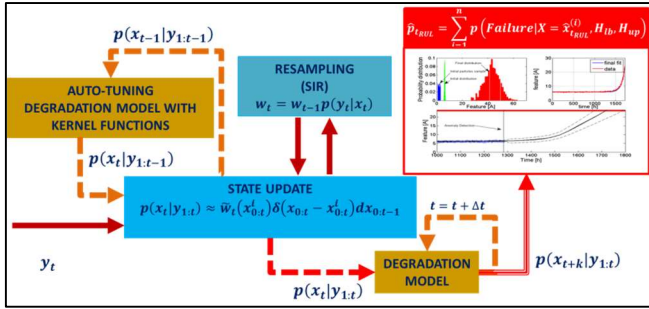

Figure 8 - The prognostic framework

7. THE HIGH-FIDELITY MODEL

The followed approach is based on the definition of an integrated framework for fault diagnosis and failure prognosis relying on systems engineering principles and taking advantage of physics-based failure modeling, state-of-the-art analytics available data from seeded fault tests. One of the most complicated and time-consuming aspects of the design of a PHM system lies in the experimental observation of the fault evolution pattern through extended stress-test campaigns. These tests are usually extremely lengthy and costly, and are usually not able to completely represent all the factors contributing to the uncertainty over the behavior of the available signals during real-flight conditions. To solve this issue and ensure the optimum selection and extraction of features associated with the system health status starting from characteristics signatures of the available signals, we opted to define a high-fidelity model, or virtual test-bench, of the real device under analysis. The model is then validated for nominal health conditions and compared with the results of experimental data derived from tests performed under controlled degradation conditions. The dynamic model of the EHSA, presented in more detail in (De Martin, Dellacasa, et al., 2018), follows a physics-based approach in which sets of differential equations describing the correlations between the state variables of the system are used. The servovalve model is based on the work of Urata (Urata, 2007b, 2007a; Urata & Suzuki, 2011), and (Jelali & Kroll, 2003), considering the presence of leakages within the valve flowing from the high-pressure environments to the tank and consider the variations of the local hydraulic resistances in function of the fluid Reynold's number. Since the Reynold's number is dependent also on the fluid viscosity, the influence of temperature variations over the valve behavior is introduced through a punctual description of the physical properties of the employed oil. The hydraulic actuator is described as a three-degree of freedom system and follows the equations provided in (Autin et al., 2018). The effect of coulomb friction on the cylinder dynamic is modelled according to (Martini, 2018),

where it is presented as a function of the dynamic condition of the rod, of the geometrical and physical data of the seal and of the pressures in the actuator. The aerodynamic surface itself is modelled as an elastic element, taking into account the stiffness of the airframe structure and of the spherical joints which connects it to the two actuators. The aerodynamic force is computed according to the Dryden Turbulence model as a function of the flight conditions and the wind speed, and includes the possible presence of sudden gusts. The whole measurement and control chain is represented as well. Each measure is hence obtained through the physics-based or functional model of each sensor, the A/D and D/A converters, the microprocessors closing the position control loops and the control laws themselves.

7.1. Degraded conditions

The dynamic model of the system allows the injection of a selected number of faults, which can be inserted as degradations of fixed severity (i.e. a crack of a certain length) or as failure mode which can progressively evolve according to the simulated conditions (i.e. a crack progressing up to its critical size). The first component interested by fault injection is the feedback spring of the servo valve. As per Section 4.1, two failure modes are addressed: the growth of a crack within the spring, leading to its rupture, and the generation of an increasing backlash due to the relative motion between the spring ends and the connected components (jet-pipe and spool). The main effect of the presence of a crack in the feedback element is the decrease of the spring stiffness due to the reduction of the area of the resistant cross-section. In first approximation the decrease can be considered proportional to the third power of the crack size. Defect propagation is modelled according to the Paris' Law for mode I opening of the crack (Anderson, 2019; Paris & Erdogan, 1963; Pugno et al., 2006), where the variations of the stress intensity factor are computed starting from the force acting on the feedback spring due to its motion at the considered oil temperature. The occurrence of backlash within the connections of the feedback spring is simply modelled as a dead-band over the feedback spring position. Its evolution in time follows the Archard's model of wear (Archard, 1953). The demagnetization of the torque motor can have multiple causes, but it is mainly driven by thermal fluctuations (Moosavi et al., 2014). Within the model, it is represented as a loss of magnetic properties of the materials, while its evolution is at first described through a modified version of the Arrhenius' Law. Although fairly simplistic, this approach has been widely used in the past to describe in first approximation thermally-driven degradations (De Martin et al., 2017). The last component considered in the analysis of the servo valve is the jet-pipe, where two major fault modes have been isolated: the distortion of the jet-pipe structure and the occlusion of its orifice. Distortion of the jet-pipe channel can be due to the severe vibrational environment, aggravated by the sudden occurrence of gusts. Since a precise evaluation

of the structural behavior of the wing and its vibrational behavior was not within the scope of the research programme, its evolution in time has been modelled as a function of the gust load. In the simulation environment, the distortion is represented by an ever-increasing off-set over the position of the jet-pipe channel. The occlusion of the orifice is modelled as a function of the flow-rate passing through, the contamination level of the oil and the passage area. Within the simulation, it is represented as a progressive decrease of the orifice cross-sectional area, hence causing a reduction of the hydraulic amplifier gain. The faults affecting the hydraulic actuator and selected for this research program are the occurrence of internal leakages due to seals wear, the backlash increase in the rod-end and the loss of sensitivity in the LVDT. The effect of wear of piston seals is modelled as the opening of an equivalent channel connecting the actuator's chambers. The flow is a mix of laminar and turbulent flow, as suggested in (Jelali & Kroll, 2003). Wear progression in time is described as a function of the relative speed between the rod and the cylinder, the oil pressure inside each chamber and the system geometry, as reported by (Bertolino et al., 2018). Increase of the backlash in the actuator rod-end is due to wear associated with the relative motion between the components of the spherical joints connecting the actuator rod with the aerodynamic surface and its kinematics. In this case, an elasto-backlash modelled according to (Gilardi & Sharf, 2002) is used to describe the effects of its occurrence, while its progression is again modelled following the Archard's Law. Loss of sensitivity in the LVDT is modelled in a similar way to the occurrence of turn-to-turn shorts within electric motors (Balaban et al., 2009; Brown et al., 2009). The last failure mode analyzed, the occlusion of the by-pass channel, is modelled as the progressive decrease of the flow passage area, and its evolution in time is described following the same laws adopted for the jet-pipe clogging.

7.2. Simulations

The mathematical models were implemented into Matlab\Simulink code to simulate the system behavior under highly varying operational conditions. Simulations have two main purposes; the first is to characterize the behavior of the investigated Electro-Hydraulic Servo Actuator for healthy and progressively more and more faulty conditions, hence allowing to define a set of features for the studied fault modes. Hence, simulation results were used to test the performances of the PHM routines and obtain a first approximation of their expectable results. Each of these functions is associated to a different database, one referred as the "training" and the other as the "test" database. In building both these datasets, a few rules have been established. Dataset must be representative of the disturbances acting on the EHSA's measurement system and must accurately and realistically describe the whole envelope of operational conditions which the system may face during its real working

life. Moreover, if one of the selected faults is injected within the model, the degradation must be described as a function of the operational parameters present within the simulation and do not follow a fixed degradation path. In this way, prognostic algorithm were tested against degradation patterns which shape was unknown a priori, simulating the real conditions in which they could potentially operate. To streamline the generation of data, an operational scenario was developed to simulate the EHSA behavior during in-flight and on-ground situations, where the environmental conditions were variable within fields compatible with real-life values. This operational scenario was built starting from data such as commands, loads, aircraft altitude and attitude collected during several flight and synthesized in a sequence of signals representing the position commands provided to the actuator, the load acting on it and the environmental conditions. In particular, the sequence of commands x_{ref} was described as the sum of three terms,

$$\begin{aligned} x_{ref}(t) \\ = x_{flight,c}(t) + x_{flight,v}(t) + x_{flight,g}(t) \end{aligned} \quad (4)$$

Where $x_{flight,c}(t)$ is a basic sequence of position commands given during a prototypical flight, $x_{flight,v}(t)$ is a component variable for each flight and function of the route, while $x_{flight,g}(t)$ represents the commands provided by the Flight Control Computers in response to disturbances to the aircraft attitude due to unforeseen aerodynamic loads such as gusts or heavy turbulence. Gusts can occur randomly during flight, while turbulence is described through the Dryden model employed in the dynamic simulation of the control surface. Moreover, the operational scenario includes models of the in-flight variation of the hydraulic fluid temperature, supply and return pressures of the EHSA circuit, vibration level and electrical noise on the sensors outputs. All the physical characteristics of the system properties (i.e. viscosity vs. temperature and air quantity) have been described through well-known models available in literature with the addition of normal noise to include the uncertainty of the models themselves within the simulation results. These same disturbances are introduced even during operations pursued on-ground, such as pre or post-flight checks and maneuvers. The defined operational scenario was used to perform flight simulations representative of ten different aircrafts with the same Electro-Hydraulic Servo Actuator type working under healthy conditions. The geometrical and mechanical parameters describing each device were randomly drawn from a pool of normal tolerance bands around the expected nominal values to simulate the small differences between nominally equal components due to the production and assembly process. In total, more than 100 flights were simulated for each aircraft under variable environmental conditions, counting more than 5000 flight hours. This database was then considered as a comprehensive representation of the EHSAs behavior under healthy condition. Then, each fault type was introduced within the

model, and for each fault type the flight simulations were performed up until reaching the failure conditions. This led to a database of sequences of flight of variable duration, unknown a priori. It must be underlined again that the fault evolution from small defect to catastrophic failure of the system was not dictated a priori, but was the result of the application of well-known degradation model to the variables computed through each simulation cycle. In example, the loss of the feedback spring in the servovalve due to crack propagation was modelled computing at each time step the expected stresses acting at the tip of the introduced defect, dependent on the pressure conditions and the provided command, the length of the crack and its effect on the spring performances. It is clear that some degree of approximation was needed, since these problems have been described through lumped models, although extremely detailed. Only one degradation at a time was introduced within the system, due to the preliminary nature of this study and due to the very low probability of multiple-faults situations. This same methodology could be however applied to cases of multiple or concurrent degradations.

8. EXPERIMENTAL ACTIVITIES

The experimental activities have been performed as a multiple-stage process; at first, we pursued the validation of the simulation environment working under healthy conditions, that is with no introduced degradations, by testing the behavior of a real actuator for a selected array of movement and load conditions. Hence, these operations are repeated introducing on a certain number of degradations on a few available actuators, selected from those presented in Section 4 according to practical feasibility. In this section we present the employed set-up, its most important characteristics and its application to the model validation for healthy conditions. Hence we present the modifications inserted in the test bench to physically or virtually inject a selected number of faults within the actuator. Finally, a discussion of the results and limitations of the presented experimental process is presented.

8.1. Set-up for healthy conditions

The set-up used for model validation is the modified production test-bench depicted in Figure 9. The actuator under analysis can be controlled in position while acting over an equivalent translating mass, simulating the inertia of the aerodynamic surface. On the other end of the equivalent inertia, a load hydraulic actuator can be used to impose a resistant or a driving action over the tested device. The acquisition and control module is in charge of processing the signals coming from the available sensors, store them in an external memory and define the profile of position

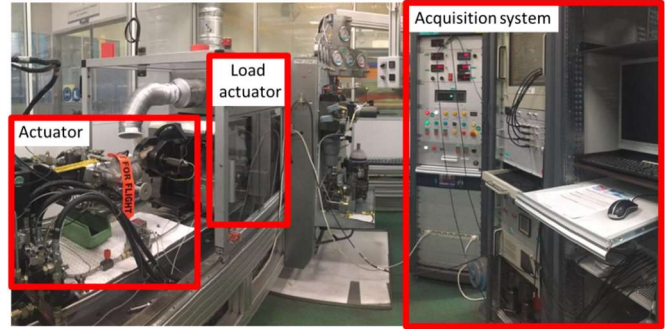

Figure 9. The experimental set-up.

command fed to the actuator. The test bench manages a number of signals, which can be roughly divided into three major categories. The first is made of those signals normally present within the Electronic Control Unit of the the Electro-Hydraulic Servo Actuator under analysis. An LVDT integral with the actuator rod is used to measure its position and infer its speed, pressure sensors are present in both actuator's chambers and another LVDT measure the position of the servovalve spool. In this category we can also consider all the signals of the position control loop (set, feedback and error), as well as the intensity of the currents injected in the first stage of the servovalve. Signals present on the test-bench and possibly available in the real application within other aircraft systems belong to the second category; here we find the measures of the supply and return channels' pressures, the temperature of the oil and of the test environment. The third and final category addresses the additional "monitoring" sensors, employed during the tests for degraded conditions to monitor the size of the injected defect. The test bench is covered by a safety glass during the tests, while cold air pumped by the conditioning system of the test facility can be used to avoid overheating due to prolonged usage.

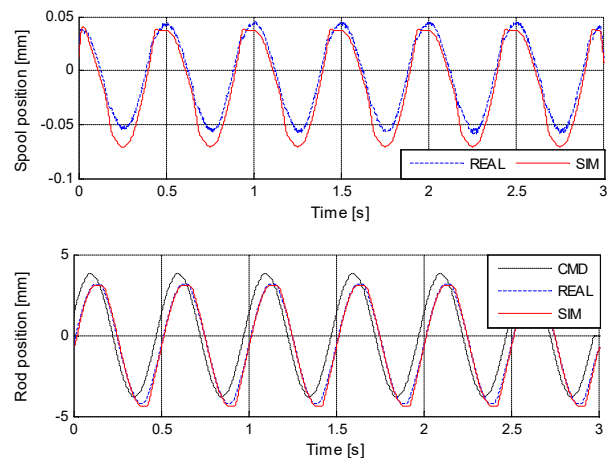

Figure 10: Comparison between experimental and simulated actuator

The set-up finally allows to impose variations over the supply pressure sent to the actuator by manually acting on the pressure reducer valve interposed between the test bed and the remote hydraulic power generator. The system was at first tested with no additional modifications with an array of sinusoidal, step and ramp commands mimicking the on-ground dedicated sequence defined in Section 5, while the load actuator was put to tank pressure. Tests were repeated under different supply pressure setting while monitoring the oil temperature. By properly tuning the model parameters, it is possible to achieve an appreciable convergence between simulation results and experimental data, as shown in Figure 10.

8.2. Physically injected degradations

The most rigorous approach to validate the model under degraded conditions is to physically inject degradations of known severity or to introduce modifications to the test bench able to reproduce the effects of the presence of one or more faults. Due to technological difficulties it was not feasible to physically inject all the fault mode described in Section 4 on the test bench. One of the most critical aspects of physically introducing a degradation within an existent system is to ensure that no additional data dispersion is introduced because of the mounting or dismounting operations and that mechanical zero of the servo-actuator remains the same after the modifications. This is extremely difficult to guarantee when dealing with components such as the servo-valve, which are directly responsible for the system behavior. Due to these reasons and the technological issues that arise when trying to access their inner parts, no physical degradation where introduced on the servovalve. We focused our attention on two failure modes affecting the hydraulic actuator: the wear of the piston seals and the occlusion of the by-pass orifice. Two other failure modes of the servovalve, the degradation of the magnetic performance of the torque motor and the occlusion of the first stage filter were addressed but did not provide useful results. The main effect of wear within the seals separating the chambers of the hydraulic actuator is the generation of an internal. To replicate this phenomenon, the test bench was modified by inserting an external by-pass between the actuator's ports. A manually-variable restrictor was interposed and a flow-meter used to measure the flow-rate by-passing the actuator, as shown in Figure 11. Then multiple tests were run while progressively opening the manually operated valve to increase the amount of leaking flowrate. Tests have been repeated varying the supply pressure between the 85% and 100% of its nominal value, while oil temperature was monitored but not controlled. The same command signals used for nominal conditions were imposed for the degraded conditions. The second failure mode considered for physically induced tests is the occlusion of the by-pass orifice which recirculates the fluid between the two actuator's chambers while operating in stand-by mode.

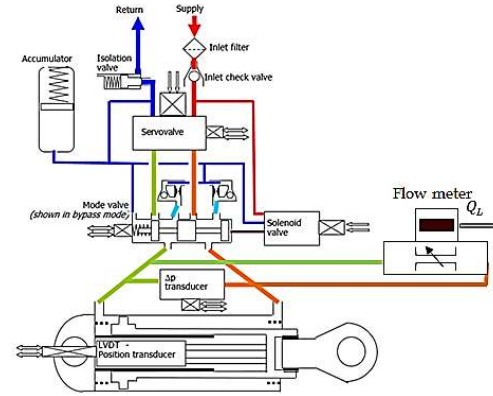

Figure 11: Modified set-up for internal leakage tests

Since this portion of the hydraulic circuit is active only when the actuator operates passively, the tests were performed by forcing the system in by-pass mode by deactivating the solenoid valve. The load actuator is then activated and used to generate a varying force acting on the tested actuator, which hence begins to operate as a damper. The behavior of the actuator under these conditions is governed by the by-pass orifice, which size determine the actuator speed in response to the pressure differential generated by the over imposed external force. We used an array of calibrated orifices of decreasing diameters to simulate the presence of a growing occlusion within this small passage. For each orifice size, several tests were performed varying the loading conditions; after each sequence, the actuator was dismantled, and the orifice replaced with a smaller one. After each replacement operation, an extensive recalibration procedure was carried out to ensure that no variations in the mechanical zero of the actuator were introduced and to guarantee that no external leakages remain. The demagnetization of the servovalve was simulated on the test-bench by rapidly commuting a big electro-valve in the near proximity of the servovalve coils. The idea in this case was to disturb the magnetic field of the torque motor with the electric field produced by the rapidly varying currents within the electro-valve windings. Unfortunately, this experiment did not provide significant results, probably due to the quality of the servovalve shielding. The last tested failure mode, the occlusion of the first stage filter within the servovalve, was injected by wrapping the cylindrical filter with polymeric material, covering the 100%, 66% and 33% of the component during each of the three tests cycles. Unfortunately, no appreciable variations of the servovalve behavior can be noticed, unless for the completely covered case. This is probably due to the value of the pressure drop across the filter, which is only a small fraction of the pressure drop caused by the narrow turns and restrictions of the circuit in the first stage of the servovalve, hence resulting almost non-influent on the valve behavior until failure conditions are reached.

8.3. Software-injected degradations

The test-bench allowed the injection of two defect by simulation, whereby simulation it is intended that the faults can be introduced acting on the software managing the measures acquisition and the actuator control. Two fault modes have been simulated this way, the generation of null-bias within the servo valve coils and the variation of the LVDT sensitivity due to shorts in the windings. Null-bias is more of a symptom of an asymmetry condition within the servovalve (i.e., due to jet-pipe distortion) more than a failure mode in itself; however, since it was extremely difficult to access the inner parts of the employed servovalve, the decision of simulating this specific behavior was the only possibility to replicate on the test-bench a well-known and frequently occurring issue. To introduce null-bias, a signal was over imposed to the current command provided to the servovalve, hence causing a variation of the neutral position of the servovalve spool compatible with that required to cause the same amount of null-bias current. The same tests performed for the leakage fault mode were performed and signals were acquired to be further analyzed. Variation of the LVDT sensitivity was introduced by manually changing the value of the gains in the measurement acquisition chain. The gain was progressively decreased up to the 85% of its nominal value, which is usually deemed as a failure condition for aeronautic applications.

8.4. Discussion on the experimental activities

The results of the experimental activities were used to better tune the high-fidelity model and evaluate the system performance in response to different degradation conditions. More importantly, experimental activities provided a database of expected behaviors of the system, where particular combinations of signals would exhibit clear correlation with the severity of the injected fault, and these observations constituted a valuable comparison term to evaluate the results coming from the simulations. At the same time, the experimental activities also come with some approximation which prevents them to completely validate the simulation results; for once, it was not possible to replicate the variations of the external temperature typical of in-flight conditions, since it was not possible to reach -54°C with the available set-up, nor it was possible to represent the whole range of static and dynamic loads affecting the actuator during real usage. At the same time, it was not possible to recreate on the test bench every fault type investigated during simulation, and some were not physically introduced but only obtained by acting on the acquisition and control software. However, despite its limits, the performed experimental activity still generated meaningful data and drove the features selection process, providing more confidence to the results of the feasibility study object of this paper.

9. FEATURE SELECTION

For each selected fault case, a feature was extracted starting from the simulated data coming from the high-fidelity model and, where possible, confirmed through the experimental results. In each case, the study started by looking at the results of the pre-flight simulations and the observation of the physical consequences of the fault injection. Hence, a few feature candidates were proposed and tested against in-flight simulations. Finally, when a few feature candidates were made available for each considered fault mode, the final features were selected according to correlation and signal-to-noise ratios, studied through Two Samples Z-tests when dealing with different faults (Vachtsevanos et al., 2007). In particular, the chosen features were the ones respecting the following criteria: maximum correlation with the severity of the associated fault and minimum correlation with every other degradation, highest signal-to-noise ratio for the associated fault and lowest against other faults. Results are reported in Table 1, where indications were provided whether simulation results were experimentally confirmed. A partial confirmation means that results were obtained from simulating the fault on the test bench or from sources different than the set-up described in Section 8. In this section we will analyze each fault mode, providing examples coming from both the simulated and the experimental results. All the experimental signals and simulation results are presented in non-dimensional form as the ratio of their maximum value for nominal health conditions.

Table 1: Features and associated faults

Component	Fault type	Features definition	Experimental confirmation
Servovalve	Cracked feedback spring/		No
	Backlash at the feedback spring attachments	$f(x_{sv}, i_{sv})$	Partial
	Torque motor degradation/ jet-pipe occlusion		No
	Jet pipe distortion	$f(i_0, i_{max})$	Partial
Actuator	Seals wear	$f(x_{sv}, \Delta p_a)$	Yes
	Occlusion of the by-pass restrictor	$f(\Delta P_{sby}, \dot{x}_a, \dot{x}_{th})$	Yes
	Rod-end wear	$f(x_a, x_{sby})$	Partial
Measurement system	LVDT loss of sensitivity	$f(V_A, V_B, V_I)$	Partial

9.1. Faults in the servovalve

Faults within the servovalve are the most difficult to successfully disambiguate through feature selection since most of them provide similar effects on the system performances. We can roughly divide the selected fault modes in three major categories. Faults which mainly cause the increase of the mechanical gain of the servovalve (the ratio between the spool displacement x_{sv} and the supplied current i_{sv}) belongs to the first. Faults like the presence of a crack in the feedback spring or an increasing backlash between the spring and its attachments are in fact likely to cause an increase in the amplitude of the spool oscillation given a certain value of currents, as depicted in Figure 12. Unfortunately, these faults provide also similar effects on other indexes, making their disambiguation difficult. The other fault modes providing similar effects on their most correlated feature candidates are those causing the decrease of the mechanical gain of the servovalve. In this second category we may list the degradation of the permanent magnets of the torque motor and the occlusion of the jet-pipe. Luckily though, these two failure modes provide different outcomes on the behavior of another index, the pressure gain of the actuator, allowing for a relatively easy classification under the hypothesis of one-fault scenarios. The final category includes faults causing the generation of an asymmetric behavior of the servovalve and hence null-bias, such as the jet-pipe distortion. This particular fault, as depicted in Figure 13, causes the generation of an off-set in the current signal (i_0), which can be easily estimated by studying the currents behavior in still-actuator conditions.

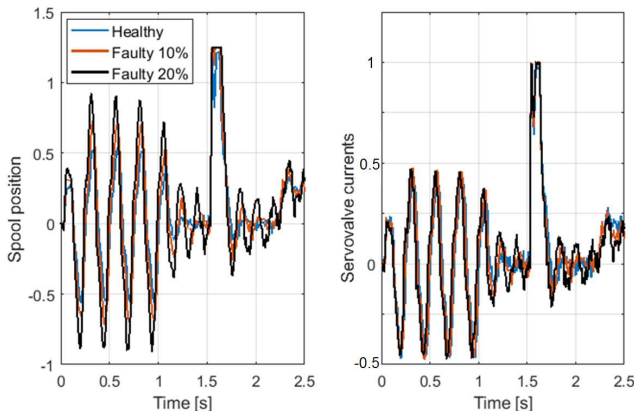

Figure 12: Effect of the progression of a crack in the servovalve feedback spring

9.2. Faults in the actuator and in the measurement system

The remaining faults can be studied through a different set of signals, which help in the definition of more unique health indexes. The primary outcome of the wear in the piston seals is the generation of leakage. As depicted in Figure 14 (a), and (b), these leakages affect the pressure

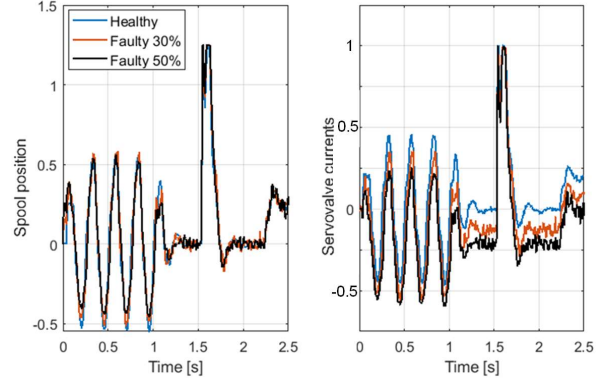

Figure 13: Effect of increasing deflection of the jet-pipe

gain of the servosystem, defined as the ratio between the pressure drop across the actuator chambers Δp_a and the spool displacement in the servovalve x_{sv} . By taking the inverse of this parameter, a positively correlated feature can be observed. Similarly, the progressive occlusion of the by-pass channel in the stand-by actuator can be observed as an increase of the pressure drop across the stand-by actuator chambers ΔP_{sby} given a certain speed of the active actuator \dot{x}_a , where the speed signal can be obtained by numerically differentiating in time the position signal provided by the LVDT. This feature can be computed only when the actuator is moving at a speed overcoming a certain threshold, as the behavior in other conditions is highly non-linear and associated with low values of signal-to-noise ratio. As shown in Figure 15 (a) and (b), this is verified through both simulation and experimental activities. Finally, the loss of sensitivity in the LVDT can be tracked by considering the ratio between the voltages V_A and V_B of its two windings with respect to the supply voltage V_I . Theoretically this value should remain constant under healthy conditions and its variation is directly correlated to the insurgence of issues in the sensor.

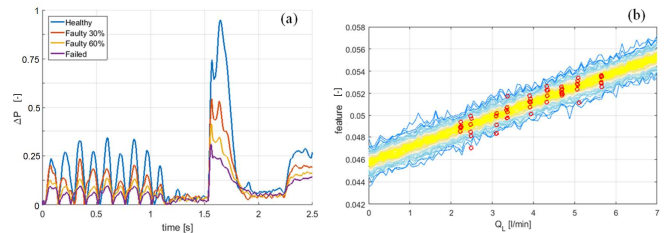

Figure 14: Internal leakages in the actuator. (a) Effect on pressure drop. (b) Experimental features (in red) vs. simulated features

10. PHM ROUTINES: RESULTS AND DISCUSSION

The PHM framework proposed in Section 6 was hence applied to the database of data coming from the simulated flights to assess a first approximation of the results potentially obtainable if such a system were applied to a real case scenario.

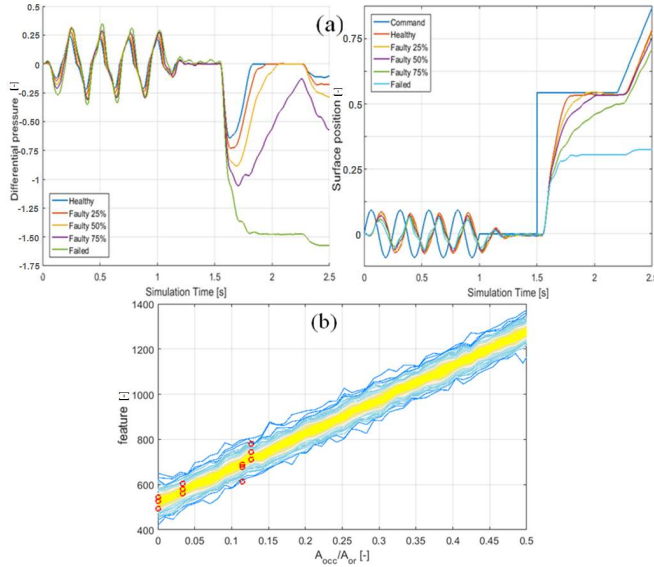

Figure 15: Occlusion of the by-pass channel. (a) Effect on pressure drop and actuator position. (b) Experimental features (red) against simulated values

Each step of the Fault Detection and Identification (FDI) process and of the prognostic analysis was studied and evaluated through metrics traditionally employed in preliminary PHM studies (Saxena et al., 2008).

10.1. Fault detection

The fault detection routine described in Section 6 was applied to several flight simulation sequences, where each sequence was affected by only one fault type. An example of the output of this analysis is reported in Figure 16, where the features distributions for healthy (in white), current (in yellow) and at fault declaration (in red) conditions are depicted for each fault

type. The system also provides in output the expected confidence associated with the fault declaration and the eventual presence of a fault alarm. The fault detection routine was able to successfully detect the early insurgence of the selected degradations in all the presented test cases; the degree of success depends on the fault type and on the behavior of the associated features. Except for the jet-pipe occlusion, which is detected on average at 42% of its critical severity, the other faults are all detected well below the 30% of their critical extension, corresponding to failure conditions.

10.2. Fault classification

The fault classification was performed through a linear Support Vector Machine and it was trained and tested on two different databases. Two different approaches were proposed and compared. The first is to train and apply the algorithm on data coming from simulated dedicated pre-flight checks performed on ground. The second is to train and apply the algorithm on data obtained through in-flight situations. Results are summarized in Table 2 and Table 3. Results are proposed for two different health conditions; the “low degradation” ones are associated with classifications performed at the first available possibility after a fault is detected, while the “mild degradation” is associated with classifications performed when the running distribution of the feature associated with the detected fault is completely divided from the healthy baseline (that is, when the confidence associated with the fault declaration becomes 100%). Results associated with in-flight conditions are provided for the “low degradation” condition only. Moreover, we divided results between correct identifications of the single fault mode, percentage of correct isolations of the fault within each sub-component and percentage of correct isolations for each component.

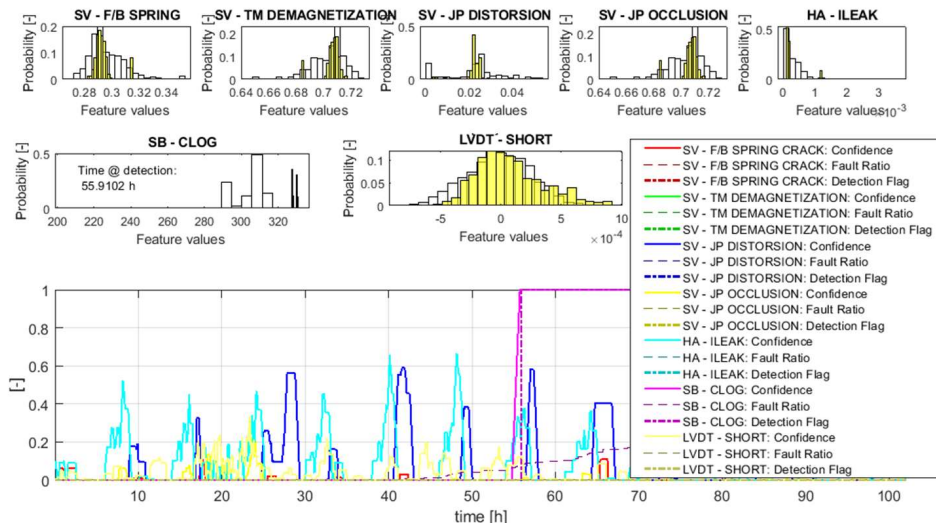

Figure 16: Example of the fault detection routine output

Table 2: Classification True Positive rate – preflight checks

Component	Element	Fault type	Low degradation	Mild degradation
Servovalve	f/b spring	Backlash	86%	98%
		Crack	60%	69%
	jet pipe	Distortion	86%	93%
		Contamination	81%	96%
	torque motor	demagnetization	55%	78%
Actuator LVDT	windings	short	85%	98%
Actuator	piston seals	wear	88%	100%
	bypass orifice	contamination	88%	96%
	Rod-end	Wear	100%	100%

The first key consideration on these results is that the classification process works better in the semi-controlled on-ground conditions rather than during the heavily disturbed in-flight operations. Delving into the results associated with the dedicated pre-flight checks, it is observable that most of the miss-classification occurs between faults affecting the same sub-component or the same component, and that the classification outcome is more and more accurate as the degradation progress. To better explain the results reported in Table 2 and Table 3, we may refer to the case of a crack in the feedback spring. Of the test data set, only the 60% of cases is correctly classified.

Table 3: Classification True Positive rate – in-flight monitoring

Component	Element	Fault type	Low degradation	Mild degradation
Servovalve	f/b spring	backlash	62%	96%
		crack	50%	67%
	jet pipe	Distortion	77%	92%
		contamination	59%	95%
	torque motor	demagnetization	50%	77%
Actuator LVDT	windings	short	85%	98%
Actuator	piston seals	wear	81%	100%
	bypass orifice	contamination	79%	96%

Rod-end	Wear	100%	100%
---------	------	------	------

However, most of the misclassification are attributed to the “backlash” fault mode; hence, the 83% of faults affecting the feedback spring are anyway attributed to this component, while the remaining are associated to other sub-components. Then, the 93% of the faults affecting the servovalve are recognized as progressive degradations acting on that component, while the remaining 7% is attributed to other components. Of particular interest is to notice that the system can successfully identify the faulted component or sub-component more than 90% of the times for each examined mild-level fault modes apart from the degradation of the torque motor.

10.3. Failure prognosis

Failure prognosis was evaluated by applying a SIR particle filter on the in-flight simulated data for each degradation scenario, where a different set of non-linear degradation model describing the feature-fault size relation and non-linear, time-dependent fault evolution model were provided to the algorithm depending on the degradation type identified by the classification algorithm. Thresholds for failure declarations were obtained through simulation and are probability distributions representative of the possible size of the defect when failure occurs (i.e. possible critical lengths of a developing crack) and of the value of the associated features. Results were then analyzed through metrics traditionally employed in the preliminary analysis of PHM systems like the mean relative accuracy (RA), Cumulative Relative Accuracy (CRA) and the definition of a prognostic horizon (PH) associated with a certain relative accuracy threshold (Saxena et al., 2008). Although more rigorous metrics can be found in literature, mainly assessing the capability of the prognostic routine of estimating the probability distribution of the real Remaining Useful Life of the component (Acuña & Orchard, 2017), the presented study is focused on a first assessment of the feasibility and the benefit of a prognostic system for this particular application and not on the research for a new, more accurate technique for prognosis, which is to be pursued in other stages of the development process. An example of the output of the particle-filter based routine can be found in Figure 17, referring to the occlusion of the by-pass channel within the actuator in stand-by mode. The histograms represent the estimated distributions for the fault size (hidden state) and the feature during the particle filter initialization, at fault detection and at the time of prediction, while past estimates of both the fault size and the computed features are represented as a function of time along their long-term forecast. Results for the analyzed fault conditions and a relative accuracy margin of $\pm 20\%$ are reported in Table 4. Results are averaged over each considered degradation pattern. Most of the simulated degradation modes provides reasonably acceptable results during prognosis, allowing to

obtain fairly accurate estimates of the remaining useful life which are in-line with the expectations, given the preliminary nature of this study. The exception being the occlusion (contamination) of the jet-pipe, which features is heavily disturbed in-flight, making it not suitable for long-range aircrafts. It must be underlined that these results are obtained assuming that the occurring faults are correctly classified by the fault diagnosis routine. If such event would occur, the prognostic algorithm would load the wrong set of process and state models, hence providing largely inaccurate results. However, as discussed in section 10.2, the diagnostic performances are expected to improve as the degradation progresses, and the feature distribution further separates from the classification boundaries.

10.4. Discussion and preliminary design assessment

Results of the preliminary evaluation of the performances of a PHM system to the electro-hydraulic servo actuator have provided positive results concerning the feasibility of the work and its merits; some critical points however emerged. The first is the difficulty in extracting features insensitive to the presence of faults different from the one they are associated to. This is in part due to the high-level of detail utilized in the description of the failure modes within the servo valve, but it is for the most imputable to the lack of some localized measures within the EHSA components, especially in the first stage of the servovalve. The missing information are however extremely difficult to obtain in the current landscape and are surely not available in legacy equipment. Despite this lack of uniqueness, the selected features were still suitable to build a classification tool, which provided reasonably positive results, especially when used on data coming from semi-controlled operating conditions such as the dedicated pre-flight checks. Finally, results of the prognostic routine were encouraging, but further work is due before porting the proposed PHM technique to a real case scenario.

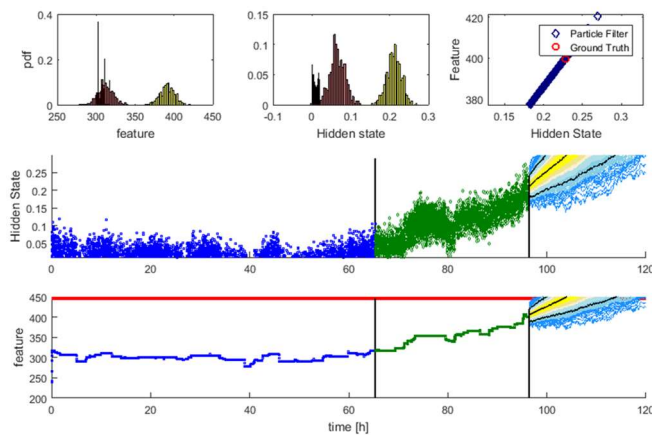

Figure 17: Example of the output of the prognostic algorithm

Table 4: Results of the prognostics algorithm

Component	Element	Fault type	RA	CRA	PH
Servo valve	feedback spring	backlash	74 %	76%	80 h
		crack	88 %	89%	36 h
	jet pipe	distortion	83 %	86%	29 h
		contamination	64 %	72%	2 h
	torque motor	demagnetization	83 %	88%	42 h
Actuator LVDT	Winding	short	80 %	82%	30 h
Actuator	piston seals	wear	88 %	88%	44 h
	bypass orifice	contamination	68 %	73%	15 h
	Rod-end	Wear	89 %	91%	100 + h

Under these considerations, the optimal strategy to achieve an effective fault diagnosis and failure prognosis on electro-hydraulic servo actuators for flight control system should be based around a combination of fault detection and prognosis based on in-flight data, while fault classification should make use of signals coming from dedicated movement of the actuators during on-ground operations.

11. CONCLUSIONS

The feasibility study presented in this paper is focused on demonstrating the possibility of creating an effective PHM system for EHSAs used in primary flight control systems, considering the results coming from both theoretical and experimental activities. Starting from previously published work and expanding the theoretical analysis to consider other major failure modes, a rigorous and fully comprehensive approach was undertaken for describing the faults and their progression based on physics models, identifying the most significant features, simulating aircraft flights in a realistic environment, collecting data, processing them, and developing data-driven fault detectors capable of detecting the occurrence of faults in their incipient stages for a safety critical aircraft actuation system. A set of novel features was derived from the simulated data set without the need of additional sensors. Furthermore, a new dedicated experimental setup was prepared and used to extract meaningful data to strengthen the simulation results. Results of this activity were positive, although they highlighted a few characteristics of the currently operating EHSAs that limit the effectiveness of current health monitoring techniques. Hence, the study was further advanced through the definition and

evaluation of a fault classification routine based upon linear SVMs. To complete the study, a particle filtering algorithm was employed to estimate the probability distribution of the remaining useful life of the EHSA. Overall, the research programme provided promising results highlighting the merits associated with the design of a PHM system for EHSAs; additional work is however needed to discuss its practical implementation and related issues. Finally, the feasibility study is focused on a specific application, the presented PHM architecture and the employed methodology can be applied to other aeronautic systems and application domains.

REFERENCES

- Acuña, D. E., & Orchard, M. E. (2017). Particle-filtering-based failure prognosis via sigma-points : Application to Lithium-Ion battery State-of-Charge monitoring. *Mechanical Systems and Signal Processing*, 85, 827–848. <https://doi.org/10.1016/j.ymssp.2016.08.029>
- Acuña, D. E., & Orchard, M. E. (2018). A theoretically rigorous approach to failure prognosis. *Proceedings of the 10th Annual Conference of the Prognostics and Health Management Society 2018 (PHM18)*.
- Anderson, T. L. (2019). Linear Elastic Fracture Mechanics. In *Fracture Mechanics*. <https://doi.org/10.1201/9781315370293-2>
- Archard, J. F. (1953). Contact and rubbing of flat surfaces. *Journal of Applied Physics*. <https://doi.org/10.1063/1.1721448>
- Arulampalam, M. S., Maskell, S., Gordon, N., & Clapp, T. (2007). A tutorial on particle filters for online nonlinear/nongaussian bayesian tracking. In *Bayesian Bounds for Parameter Estimation and Nonlinear Filtering/Tracking*. <https://doi.org/10.1109/9780470544198.ch73>
- Autin, S., Socheleau, J., Dellacasa, A., De Martin, A., Jacazio, G., & Vachtsevanos, G. (2018). Feasibility Study of a PHM System for Electro-hydraulic Servo-actuators for Primary Flight Controls. *Annual Conference of the Prognostic and Health Management Society*, 1–19.
- Balaban, E., Saxena, A., & Goebel, K. (2009). Experimental data collection and modeling for nominal and fault conditions on electro-mechanical actuators. *Annual Conference of the Prognostics and Health Management Society*, 1–15.
- Bertolino, A. C., Gentile, R., Jacazio, G., Marino, F., & Sorli, M. (2018). EHSA primary flight controls seals wear degradation model. *ASME International Mechanical Engineering Congress and Exposition, Proceedings (IMECE)*. <https://doi.org/10.1115/IMECE2018-87080>
- Brown, D. W., Georgoulas, G., & Bole, B. M. (2009). Prognostics Enhanced Reconfigurable Control of Electro-Mechanical Actuators. *Annual Conference of the Prognostics and Health Management Society*.
- Byington, C. S., Watson, M., & Edwards, D. (2004). Data-driven neural network methodology to remaining life predictions for aircraft actuator components. *IEEE Aerospace Conference Proceedings*. <https://doi.org/10.1109/AERO.2004.1368175>
- Chen, Y., Mo, Z., Xie, L., & Miao, Q. (2019). Fault Detection and Diagnosis of Aircraft Electro Hydrostatic Actuator Control System. *Proceedings - 2018 Prognostics and System Health Management Conference, PHM-Chongqing 2018*. <https://doi.org/10.1109/PHM-Chongqing.2018.00172>
- Dalla Vedova, M., Maggiore, P., Jacazio, G., & Sorli, M. (2010). Identification of Precursors of Servovalves Failures for Implementation of an Effective Prognostics. *4th International Conference on Recent Advances in Aerospace Actuation Systems and Components*.
- De Martin, A., Dellacasa, A., Jacazio, G., & Sorli, M. (2018). High-Fidelity Model of Electro-Hydraulic Actuators for Primary Flight Control Systems. *Proceedings of the 2018 Bath/ASME Symposium on Fluid Power and Motion Control FPMC2018 September 12-14, 2018, University of Bath, United Kingdom, 4, V001T01A058*. <https://doi.org/10.1115/fPMC2018-8917>
- De Martin, A., Jacazio, G., & Sorli, M. (2018). Enhanced Particle Filter framework for improved prognosis of electro-mechanical flight controls actuators. *PHM Society European Conference*, 4(1).
- De Martin, A., Jacazio, G., & Vachtsevanos, G. (2017). Windings fault detection and prognosis in electro-mechanical flight control actuators operating in active-active configuration. *International Journal of Prognostics and Health Management*, 8(2).
- Gilardi, G., & Sharf, I. (2002). Literature survey of contact dynamics modelling. *Mechanism and Machine Theory*. [https://doi.org/10.1016/S0094-114X\(02\)00045-9](https://doi.org/10.1016/S0094-114X(02)00045-9)
- Guo, R., & Sui, J. (2019). Remaining Useful Life Prognostics for the Electro-Hydraulic Servo Actuator Using Hellinger Distance-Based Particle Filter. *IEEE Transactions on Instrumentation and Measurement*. <https://doi.org/10.1109/tim.2019.2910919>
- International Air Transport Association (IATA). (2011). *Airline Maintenance Cost Executive Commentary - An exclusive benchmark analysis (FY2009 data) by IATA's Maintenance Cost Task Force*.
- Jelali, M., & Kroll, A. (2003). *Hydraulic Servo-systems*. Springer. <https://doi.org/10.1007/978-1-4471-0099-7>

- Marla, Lavanya & Vaaben, Bo & Barnhart, C. (2012). Integrated Disruption Management and Flight Planning to Trade Off Delays and Fuel Burn. *51st AGIFORS Annual Proceedings - Annual Symposium and Study Group Meeting, AGIFORS 2011*. 1. 10.1287/Trsc.2015.0609.
- Martini, L. J. (2018). Practical Seal Design. In *Practical Seal Design*. Taylor & Francis. <https://doi.org/10.1201/9780203744109>
- Moosavi, S. S., Djerdir, A., Amirat, Y. A., & Khaburi, D. A. (2014). Demagnetization fault investigation in permanent magnet synchronous motor. *PEDSTC 2014 - 5th Annual International Power Electronics, Drive Systems and Technologies Conference, Pedstc*, 617–623. <https://doi.org/10.1109/PEDSTC.2014.6799448>
- Nesci, A., De Martin, A., Jacazio, G., & Sorli, M. (2020). Detection and Prognosis of Propagating Faults in Flight Control Actuators for Helicopters. *Aerospace*, 7(3), 20. <https://doi.org/10.3390/aerospace7030020>
- Orchard, M. E., & Vachtsevanos, G. J. (2009). A particle-filtering approach for on-line fault diagnosis and failure prognosis. *Transactions of the Institute of Measurement and Control*. <https://doi.org/10.1177/0142331208092026>
- Paris, P., & Erdogan, F. (1963). A critical analysis of crack propagation laws. *Journal of Fluids Engineering, Transactions of the ASME*. <https://doi.org/10.1115/1.3656900>
- Pugno, N., Ciavarella, M., Cornetti, P., & Carpinteri, A. (2006). A generalized Paris' law for fatigue crack growth. *Journal of the Mechanics and Physics of Solids*. <https://doi.org/10.1016/j.jmps.2006.01.007>
- Roemer, M. J., Byington, C. S., Kacprzynski, G. J., Vachtsevanos, G., & Goebel, K. (2011). Prognostics. In *System Health Management: With Aerospace Applications*. <https://doi.org/10.1002/9781119994053.ch17>
- Saxena, A., Celaya, J., Balaban, E., Goebel, K., Saha, B., Saha, S., & Schwabacher, M. (2008). Metrics for evaluating performance of prognostic techniques. *2008 International Conference on Prognostics and Health Management, PHM 2008*. <https://doi.org/10.1109/PHM.2008.4711436>
- Urata, E. (2007a). Influence of unequal air-gap thickness in servo valve torque motors. *Proceedings of the Institution of Mechanical Engineers, Part C: Journal of Mechanical Engineering Science*. <https://doi.org/10.1243/09544062JMES709>
- Urata, E. (2007b). On the torque generated in a servo valve torque motor using permanent magnets. *Proceedings of the Institution of Mechanical Engineers, Part C: Journal of Mechanical Engineering Science*. <https://doi.org/10.1243/09544062JMES584>
- Urata, E., & Suzuki, K. (2011). Stiffness of the elastic system in a servo-valve torque motor. *Proceedings of the Institution of Mechanical Engineers, Part C: Journal of Mechanical Engineering Science*. <https://doi.org/10.1177/0954406211403072>
- Vachtsevanos, G., Lewis, F., Roemer, M., Hess, A., & Wu, B. (2007). Intelligent Fault Diagnosis and Prognosis for Engineering Systems. In *Intelligent Fault Diagnosis and Prognosis for Engineering Systems*. <https://doi.org/10.1002/9780470117842>

Biographies

Sylvain Autin Sylvain Autin is a Systems Performance Engineer at UTAS Actuation Systems in France; Sylvain has a Master's Degree in Electrical Engineering and Signal Processing from the "Institut National des Sciences Appliquées" French Engineering School in Lyon. He started his career in navigation systems in 2008. Since 2012, Sylvain has been working in Aircraft Primary Flight Controls domain at UTAS. He participated actively to the development of primary flight control actuation systems for More Electrical Aircraft involving state of the art "Fly By Wire" and EHA technologies He developed advanced systems monitoring and led the development of flight controls virtual test bench to support aircraft certification. Sylvain is currently leading the development of PHM Technology for Primary Flight Control Actuators for UTC Aerospace Systems.

Andrea De Martin is assistant professor at Politecnico di Torino, Italy. He graduated from the same university in 2013 and has since been member of the Mechatronics and Servosystems research group, where he pursued a PhD in Mechanical Engineering. His main research interests are in the area of Prognostics and Health Management for industrial and aerospace applications, with a major focus on the development of new PHM schemes for flight control systems.

Giovanni Jacazio has been full professor of Applied Mechanics and lecturer of control systems at Department of Mechanical and Aerospace Engineering, Politecnico di Torino, Turin, Italy, until 2015, now retired. He is lecturing courses on fly-by-wire flight control systems and PHM in the Doctoral School of Politecnico di Torino and consulting for UTAS. His main research activities are in the areas of flight control systems for aerospace applications and of prognostics and health management. He has been Research Leader for several European and national research programs, Coordinator of research and consulting activities for several engineering industries. He is member of the SAE A-6 committee on Aerospace Actuation Control and Fluid Power Systems, and fellow of the Prognostics and Health Management Society.

Jérôme Socheleau currently serves as Head of Systems Group at UTAS Actuation Systems in France; he is also involved in Technology Programs Execution. Prior to these roles, Jérôme led the Performance Department at Goodrich Saint-Ouen l'Aumône, France. Jérôme has been working for more than 20 years in Aircraft Primary Flight Controls domain; he developed several primary flight control actuation systems for new aircraft involving state of the art "Fly By Wire" technology. Between 2001 and 2006, he led the introduction and the certification of first EHAs on commercial aircraft (A380). Then, he participated to the development of several innovative primary flight control actuator prototypes in the field of Research and Technology projects, these include hybrid Electrically Assisted Hydraulic Actuator (EAHA) and ElectroMechanical Actuator (EMA). Jérôme received a Master's Degree in Aeronautics at the French Engineering School "Ecole Nationale Supérieure de Mécanique et d'Aérotechnique" at Poitiers.

George Vachtsevanos is a Professor Emeritus of Electrical and Computer Engineering at the Georgia Institute of Technology. He was awarded a B.E.E. degree from the City College of New York in 1962, a M.E.E. degree from New York University in 1963 and the Ph.D. degree in Electrical Engineering from the City University of New York in 1970. He directs the Intelligent Control Systems laboratory at Georgia Tech where faculty and students are conducting research in intelligent control, neurotechnology and cardiotechnology, fault diagnosis and prognosis of largescale dynamical systems and control technologies for Unmanned Aerial Vehicles. His work is funded by government agencies and industry. He has published over 300 technical papers and is a senior member of IEEE. Dr. Vachtsevanos was awarded the IEEE Control Systems Magazine Outstanding Paper Award for the years 2002-2003 (with L. Wills and B. Heck). He was also awarded the 20022003 Georgia Tech School of Electrical and Computer Engineering Distinguished Professor Award and the 20032004 Georgia Institute of Technology Outstanding Interdisciplinary Activities Award.