

Analysis of the energy consumption of a rotary harrow

Original

Analysis of the energy consumption of a rotary harrow / Raparelli, Terenziano; Ivanov, Alexander; Pepe, Giuseppe; Eula, Gabriella. - In: JOURNAL OF AGRICULTURAL ENGINEERING. - ISSN 2239-6268. - ELETTRONICO. - (2021), pp. 1-21. [10.4081/jae.2021.1132]

Availability:

This version is available at: 11583/2875526 since: 2021-03-22T11:52:03Z

Publisher:

Pavia : Pagepress

Published

DOI:10.4081/jae.2021.1132

Terms of use:

This article is made available under terms and conditions as specified in the corresponding bibliographic description in the repository

Publisher copyright

(Article begins on next page)

Analysis of the energy consumption of a rotary harrow

Terenziano Raparelli, Alexandre Ivanov, Giuseppe Pepe, Gabriella Eula

Department of Mechanical and Aerospace Engineering, Politecnico di Torino, Torino, Italy

Correspondence: Gabriella Eula, Department of Mechanical and Aerospace Engineering, Politecnico di Torino, Torino, Italy. E-mail: gabriella.eula@polito.it

Key words: Harrow tines and soil interaction; harrow tines during the soil operation analysis; harrow tines and soil models; energy consumption in a rotary harrow; harrow tines functioning simulation.

Acknowledgements: this study was carried out as part of the PRIN project: (Progetti di ricerca di Rilevante Interesse Nazionale - bando 2015 “*Ottimizzazione di macchine operatrici attraverso l’analisi del profilo di missione per un’agricoltura più efficiente*” durata 2017-2020) (Research projects of significant national interest - notification 2015 “*Optimization of operating machinery through analysis of the mission profile for more efficient agriculture*” duration 2017-2020).

Abstract

This paper shows the development and study of a FEM model of a rotary harrow. A proper use of a rotary harrow depends on its geometry and on the working parameters, such as: drag speed and angular speed. The aim of this work is to develop a rotary harrow model in the ANSYS environment in order to analyze and to optimize its geometric parameters. The model, validated through comparison with some experimental data, was then used to analyze the forces exchanged between the tines and the soil as a function of the drag speed, the angular speed and the working depth. Different tine orientations and three different types of terrain were considered.

Introduction

The rotary harrow is a tool brought by the tractor, used to refine the soil before sowing or for the weed control. It is driven by means of a power take-off (PTO) and it is characterized by a series of vertical axis rotors each rotating opposite to the rotor nearby and equipped with vertical tines. The motion from the PTO is transmitted to the rotors by means of a reduction gear and a series of gear wheels.

This study considers that the tillage involves many factors that often modify the physical properties of the soil, such as: texture, structure, bulk density, porosity, soil moisture, modifying them following the tillage (Cavazza, 1981; Terzaghi et al., 1996). Large amounts of energy are consumed during tillage operations because of the high draft forces required (Kushwaha et al., 1993). In fact, tillage is a procedure of breaking and loosening of soil, and it fragments the soil into small aggregates (Berntsen and Berre, 2002).

Soil preparation by means of a rotary harrow is a complex process and must satisfy various needs. Three main problems can be highlighted: reliability of a harrow structure, energy efficiency of the process, quality of soil preparation. The present study focused on the problem of the energy

consumption of a rotary harrow. As already mentioned, during the tillage phase each rotor is subjected to two movements: a horizontal dragging movement and a rotation around its own vertical axis. These movements, according to the speeds, create a complex movement of the rotary tines, mounted on the rotor (Raparelli et al., 2020). To overcome the resistance of the soil, subjected to tillage, and to maintain the drag and the angular speeds, it is necessary to apply a certain power. This power depends both on the geometry of the harrow tines and on the tillage parameters. As parameters of the tillage it is necessary to consider: the two speeds; the depth of the tillage; the characteristics of the soil. To calculate this power it is necessary to simulate the interaction between the tines and the soil, that is to the more general case of the tool-soil interaction. The studies conducted in this area are numerous and have led to the development of models that can be essentially classified into three categories: analytical models (Terzaghi, 1947; Swick and Perumpral, 1988; Kushwaha and Linke, 1996), empirical models (Luth and Wismer, 1971; Harrigan and Rotz, 1995) and numerical models (Yong and Hanna, 1977; Plouffe et al., 1999; Shinde et al., 2011; Chen et al., 2013).

The analytical models provide data related to the tool-soil interaction in a very fast way, but with high approximation. The empirical models provide data closer to physical reality, but require numerous and complex experimental measurements, with a high expense of resources and time. The numerical models also provide very accurate results as long as you are able to realistically define the properties of the involved materials, the interface conditions and the constraint and load conditions. However, these models require experimental validation. Finite element numerical models (FEM) are very widespread. Their application to the study of harrow - soil interaction is however limited. A first approach to the study harrow - soil interaction was addressed by the same authors in (Raparelli et al., 2019).

The approach to studying the interaction of the harrow and soil using numerical modeling was considered by the same authors in (Raparelli et al., 2019), when the kinematics of the process was mainly considered. To obtain dynamic characteristics, it is necessary to use other computational

schemes, among which the main ones are numerical models using finite elements (FEM). This work is devoted to the creation of a numerical model that would allow determining the dynamic characteristics of the rotary harrow, force and power consumption, as a function of its geometric dimensions and some operating parameters such as the speed and depth of soil cultivation. Obviously, the use of this model in practice should take place with the simultaneous control of other parameters, since the model describes only the reaction of the soil to the harrow tine, and does not provide detailed information about the state of the soil after passing the tine. The model may be used in the design and optimization of the rotary harrow along with other tools that would provide control over the quality of soil cultivation, strength, manufacturability etc..

The use of the model together with data on the quality of tillage under a particular regime or a particular choice of the type of harrow tines could also make it possible in the future to develop recommendations for reducing energy consumption during agricultural work.

Materials and methods

Development of the rotary harrow tine FEM model

Generally a rotary harrow has a series of rotors, having two tines; that are moved by means of a series of gear wheels. They received the movement from the tractor PTO with a Cardan shaft drive interposed, (Raparelli et al., 2018). Therefore, the rotor of the rotary harrow was modeled as two tines, positioned on a disk, as this is the effective geometry used by the constructors. Figure 1 shows a view of the model of a rotor. This choice is justified by the standard geometry used in this implement and by the model used in the numerical simulations by the Authors (Raparelli et al., 2019, 2020). Considering that during the tillage operation the soil interacts only with the tines of the rotor, it is possible to simplify the shape of the rotor.

The shape of the tine and its position on the rotor has been modeled in the SOLIDWORKS environment, which allows to easily design the geometry: for example, in this case, it is possible to vary without great difficulty the orientation of the tines on the rotor. In the study, a rotor with a diameter of 0.25 m was chosen. The angle of the position of the tine on the rotor is a variable. Figure 2 shows the schema of a part of the rotor, viewed from above. The rotation speed is here considered counterclockwise, and the α angle is the rotation angle of the tine respecting the axis of the rotor. The α angle is positive in case of counterclockwise rotation and negative in case of clockwise rotation.

The tine shape was chosen from the models of the commercial used tines. The tine shape with its specific dimensions is shown in Figure 3. This tine has high stiffness: this allows to neglect the flexibility of the tines and its length allows to neglect the interference between the rotor body and the soil. The numerical model of the study was built in the ANSYS Explicit Dynamics module. The model must have to allow performing the rotor movement with a certain configuration of the tines in a block of soil. To avoid the excessive forces that are developed in the beginning of the rotor movement, the rotor penetrates the soil block on one side with constant linear speed and angular speed and with a constant working depth. Figure 4 shows the initial step of the simulation. The linear trajectory of the rotor drag movement imposed is equal to about two of its diameters: this allows to stabilize its movement. During the movement the forces were recorded, acting on the rotor in the direction of its linear movement and the total work done.

This makes it possible to determine the total power consumption P_{tot} , and the power required to move the harrow P_{mov} . Obviously, the power taken from the PTO for the rotation of the harrow P_{rot} is equal to the difference between P_{tot} and P_{mov} .

Developing a FEM model, one of the main problems is to choose a soil material model. Unfortunately, this choice cannot be made on the basis of knowledge of the chemical properties and composition of the soil, for example, using the triangular diagram of soils (Giordano, 1999). The percentage of substances in the soil does not directly determine the characteristics of the model material, and

different soil models may be required for different tasks. One of the recommended models is the model MO Granular (Laine and Sandvik, 2001). MO Granular model is an extension of the Drucker-Prager model that takes into account effects associated with granular materials such as powders, soil and sand. It combines compaction EOS model with the Moxnes and Ødegardstuen granular strength model. In addition to pressure hardening, the model also represents density hardening and variations in the shear modulus with density. The yield stress is made up of two components, one dependent on the density and one dependent on the pressure. The unload/reload slope is defined by the shear modulus which is defined as a function of the zero pressure density of the material. The yield stress is defined by a yield stress - pressure and a yield stress - density curve and the shear modulus is defined by a shear modulus - density curve.

Three types of standard materials from the ANSYS material library were used as material which represents the soil: Silty Sand, Sandy Clay and Sand. Simulations of the rotor movement were carried out. The choice of Sand as one of the model soil materials was made due to the fact that its characteristics are well studied and it is the limiting case for the triangular diagram of soils when the content of other components is zero (Giordano, 1999).

The working parameters of the harrow were selected based on their characteristic values. The maximum tillage depth for the selected tine geometry (Fig. 3) does not exceed 23 cm, and should actually be less. Rotary harrow processing at depths of less than 10 cm seems impractical. Therefore, three working depths were chosen equal to 10, 15 and 20 cm. The drag speed of the rotor and the angular speed of the rotor were selected based on average values, tractor speed about 4.3 km / h, PTO angular speed 540 rpm, gear ratio 0,6. Thus, drag speed of the rotor and the angular speed of the rotor were set at 1.2 m/s and 35 rad/s, respectively.

Simulations of the rotor movement were carried out varying the angle of the knife α . The angle α , according to Figure 2, was varied from + 10 ° (with the most "closed" tines), to -10 ° (with the most "open" tines).

Validation of the FEM model of the soil

To verify the applicability of the standard soil models, a series of preliminary numerical simulations dedicated to the study of the soil behavior were performed. In the simulation of the interaction between the tines of the harrow and the soil, the rotor can be assumed as a rigid body, because its stiffness is greater than that of the soil.

Since the standard soil models from ANSYS were supposed to be used in the construction of the harrow model, the validity of their application for the conditions of the developed model was initially checked.

To do this, the other ANSYS model was chosen using a soil model under similar conditions, but the parameters calculated with the ANSYS model could be easily measured.

In the model, the mass falls on the block (that simulates the soil) at a speed similar to that of the tillage operation, and the velocities and the accelerations of the soil was measured at a certain distance from the point of fall. The model was made with the ANSYS Explicit Dynamics. Figure 5 shows the results for the speed and the acceleration along the direction of propagation of the impact (the Y axis) and normal to the direction of propagation (the Z axis), 3 milliseconds after the impact. As can be seen, the speed values are very low while the acceleration in the deep zone of the block is remarkable and could be easily measured. For the tests was chosen the geometry as shown in Figure 6. To better highlight the measurement point, a small "wells" was used.

The calculations have shown that the absolute acceleration values depend slightly on the impact parameters, i.e. body speed and mass, but the characteristics do not change its behavior. Figure 7 presents some graphs of the calculation of the normalized acceleration a for the three soil models, Sand (S), Silty Sand (Ss) and Sandy Clay (Sc).

The experimental test was carried out according to the scheme in Figure 6b. To more accurately detect the time of signal propagation, two accelerometers were used, located in a straight line with the place of impact. The signal transit time was defined as the difference between the times recorded by the two sensors. This also made it possible to eliminate any delays in the signal from the accelerometers. In experiments, two accelerometers were usually used to measure accelerations along the Y and Z coordinates. Figure 8 presents two experimental results for Sand and Silty soil.

The comparison between Figures 7 and 8 highlights the similarity of the behavior between the theoretical model for Silty Sand and the result of the experimental tests: this similarity is less evident for the Sand model. This discrepancy can be caused by the moisture content of the sand.

Results of the tine-soil interaction simulation

After the preliminary analyzes concerning the impact propagation, simulations of the interaction soil tillage were carried out. The variable parameters are: the depth h and the angle α of the tine positioning. Figures 9 and 10 show some results of the calculations for Silty Sand (Ss). The working depth is 15 cm, the angle α is 0° . Figure 9 shows the graph of the force F which acts on the rotor in the direction of its displacement, as a function of the time. Figure 10 shows the graph of the energy of the system as a function of the time. The part of the power corresponding to the linear displacement was calculated by multiplying the average force with the drag speed, which was equal to 1.2 m/s.

In the first series of tests, simulations of the rotor movement were made at the three previously defined depths with α angle value equal to 0° , varying the material of the soil block. Figure 11 shows the results for the average power calculated for the three types of soil: Sand (S), Silty Sand (Ss) and Sandy Clay (Sc). In the graphs, $P_{mov.}$ (kW) is the average power required to move the rotor and $P_{tot.}$ (kW) is the total average power. The total average power is the sum of the power required for the linear movement of the rotor and the power for its rotation. The power was calculated for the last two

turns of rotor to eliminate the influence of the impact of the tine on the soil block which take place in the first moment of movement. As it may be seen, the powers for Silty Sand and Sandy Clay do not differ much from each other, and, as expected, are much more the power required when processing Sand. The results of numerical simulations have shown that the total power needed could be expressed according to the formula:

$$P_{tot} = P_0(AH^2 + BH + C) \quad (\text{Eq.1})$$

where: P_0 - power in kW at a working depth of 1 dm; H - working depth in dm; A, B and C are constant. For Silty Sand and Sandy Clay the same values of the coefficients can be used. The values of the coefficients A, B and C are shown in Table 1.

In the second series of tests, the angles of the orientation of the tines on the rotor were varied, according to Figure 2. The modeling results are presented in Figure 12, for the soil model Silty Sand (Ss) above and below for the Sand (S). As before, the reported powers are the average powers relative to the last two rotor turns without the influence of the first impact. Figure 12 shows that a slight increase in the angle α decreases the power required, both for Sand and Silty Sand. The "closing" of the tines at 5-10 degrees allows to decrease the necessary power, according to the depth and type of the soil, up to 10%. To evaluate the dynamic behavior of the power in the time the trace of rotor was divided in four parts. Each part is corresponding to the average power during a half turn, for the two turns there are four values of the average powers (for the movement of the rotor and the total one). Figures 13 and 14 show the results for the tests, Figure 13 refers to Silty Sand (Ss) and Figure 14 to Sand (S). In both cases, the creation of soil accumulations can be noted, which cause an increase in power, but for Sand the results refer to the first half turn, and for Silty Sand to the last. In any case, the use of "closed" tines, mounted at a larger angle, presents a more uniform recall of power.

Conclusions

A FEM model has been built to describe the power characteristics of the harrow rotor. This model contains a rotor with two tines, which rotates at a constant angular velocity and linear moves at a constant speed. In this case, the rotor tines interact with the soil material. During the movement of the rotor, the applied forces are fixed. This makes it possible to determine the necessary powers for its rotation and movement. The model allows to investigate the influence of speed, tillage depth, shape and position of tines on power consumption.

The same powers are applied to the ground in which the rotor tines rotate, changing its state. The description of soil transformations is a very important independent task, but this goal was not pursued in this work.

When constructing the model for soil characterization, three standard materials from the ANSYS materials library, Silty Sand, Sandy Clay and Sand soil models were used, all three types MO granular. Before investigating the characteristics of the model, a preliminary part of the study was carried out, aimed at checking the possibility of using this model of material in this task. This study, which includes the construction of a FEM model of the propagation of a mass impact on the soil at a speed similar to the speed of tillage, and the measurement of the accelerations generated by this, were compared with experimental results.

The theoretical results for the Silty Sand soil model are similar to the experimental ones, but the Sand soil model requires adjustment of some of its parameters. The obtained data, on the one hand, showed the possibility for further use of the MO granular model in the developed model, and on the other hand, revealed the need for accurate measurements of the characteristics of the cultivated soil.

For a chosen rotor geometry, the values of the required power for the Silty Sand, Sandy Clay and Sand soil models for three different working depths were examined and compared.

Based on the results of numerical modeling, a generalized formula was obtained for the power consumed by the rotary harrow for three applied soil models. The formula for the necessary power with variation of the working depth for Sand and for Silty Sand and Sandy Clay has slightly different coefficients.

Numerical tests with different positioning angles and different depth of treatment were carried out for two soil models, the Silty Sand and Sand models, because their behavior in the developed model was significantly different. These tests have shown that a slight increase in the angle decreases and uniforms the required power and decreases the energy consumption for both models.

The practical use of the elaborated model provides for a series of full-scale tests both to verify the model as a whole and to determine the characteristics of the soils used for the models. In this case, it provides an additional tool for developers of new technology. The obtained analytical dependence, in the case of its spread to a wide range of agricultural soils, can be used at the farmer's level to optimize costs, for example, by selecting the appropriate tractor capacity.

References

- Berntsen R., Berre B. 2002. Soil fragmentation and the efficiency of tillage implements. *Soil and Tillage Research*. 64. 137-147.
- Cavazza L, 1981. *Fisica del terreno agrario*. UTET, Torino, Italy
- Chen Y., Munkholm L.J., Nyord T. 2013. A discrete element model for soil-sweep interaction in three different soils. *Soil & Tillage Research*. 126:34-41.
- Giordano A. 1999. *Pedologia*. Edizioni UTET, Torino ISSN 8802053936.
- Harrigan T.M., Rotz C.A. 1995. Draft Relationships for Tillage and Seeding Equipment. *Applied engineering in agriculture*. 11(6):773-783.

- Kushwaha R.L., Chi L., Shen J. 1993 Analytical and numerical models for predicting soil forces on narrow tillage tools - a review. *Canadian Agricultural Engineering* 35(3): 183-193.
- Kushwaha R.L., Linke C. 1996. Draft-speed relationship of simple tillage tools at high operating speeds. *Soil and Tillage Research*. 39(1-2):61-73.
- Laine L., Sandvik A. 2001. Derivation of mechanical properties for sand. The Proceedings of the 4th Asia-Pacific Conference on Shock and Impact Loads on Structures, CI-Premier PTE LTD, Singapore, November 2001,,: 361-368.
- Luth H. J., Wismer R. D. 1971. Performance of plane soil cutting blades in sand. *Transactions of the ASAE*, 15(2):0211-0216.
- Plouffe C., Lague C., Tessier S., Richard M. J., McLaughlin N. B. 1999. Moldboard plow performance in a clay soil: simulation and experiment. *Transactions of the ASAE*, 42(6):1531-1539.
- Raparelli T., Eula G., Ivanov A., Pepe, G. 2018. Analisi della catena cinematica per la trasmissione del moto dal trattore a un erpice rotativo. *Organi Di Trasmissione*. ISSN 0030-4905-: 10-14.
- Raparelli T, Eula G, Ivanov A, Pepe G, Ricauda Aimonino D. 2019. Preliminary analysis of interaction among gears, tines and soil in a rotary harrow. *International Journal of Mechanics and Control*. 20(1):81-91.
- Raparelli T., Pepe G., Ivanov A., Eula G. 2020. Kinematic analysis of rotary harrows. *Journal of Agricultural Engineering*, 51(1), 9-14. <https://doi.org/10.4081/jae.2019.976>
- Shinde G.U., Potekar J.M., Shinde R.V., Kajale S.R. 2011. Design Analysis of Rotary Tillage Tool Components by CAD-tool: Rotavator. 2011 International Conference on Environmental and Agriculture Engineering IPCBEE vol.15. IACSIT Press, Singapore.
- Swick W. C., Perumpral J. V. 1988. A model for predicting soil-tool interaction. *Journal of Terramechanics*, 25(1):43-56.
- Terzaghi K. 1947. *Theoretical Soil Mechanics*. 4th ed. Chapman and Hall Wiley. London and New York.

Terzaghi K., Peck R.B. and Mesri G. 1996. Soil Mechanics in Engineering Practice. 3rd Edition. John Wiley & Sons, New York.

Yong R. N., Hanna A. W. 1977. Finite element analysis of plane soil cutting. Journal of Terramechanics, 14(3):103-125.

Accepted paper

Table 1. Coefficients for determining the power needed for the tillage.

	A (kW/dm ²)	B (kW/dm)	C (kW)
Silty Sand - Sandy Clay	1,45	-2,6	2,15
Sand	1,2	-2,6	2,4

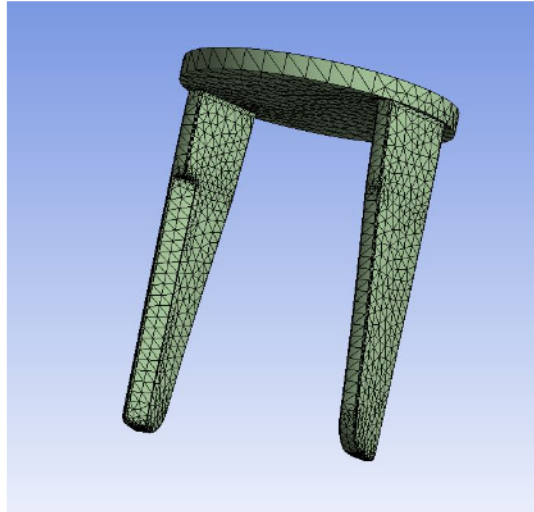

Figure 1. Model of a rotor.

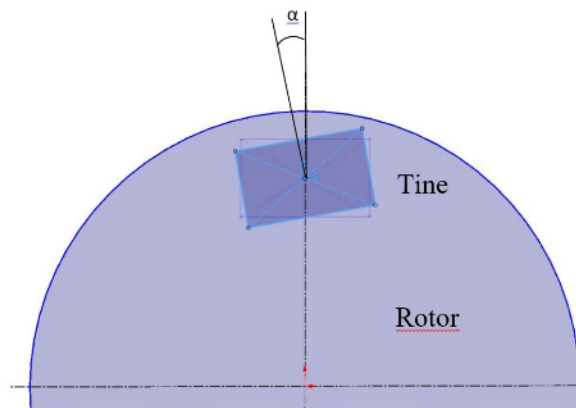

Figure 2. Schema of the position of the tine on the rotor.

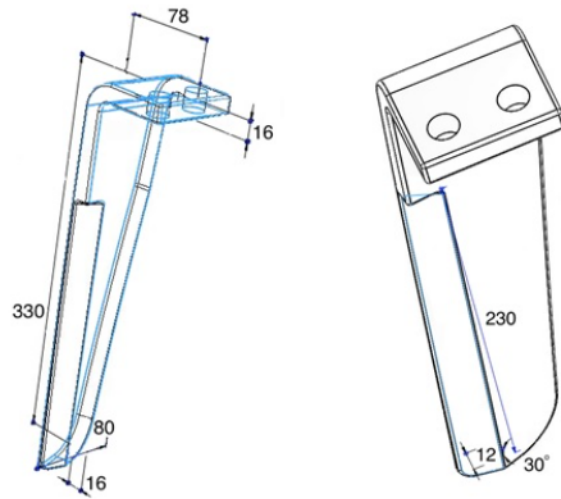

Figure 3. Tine shape with its specific dimensions.

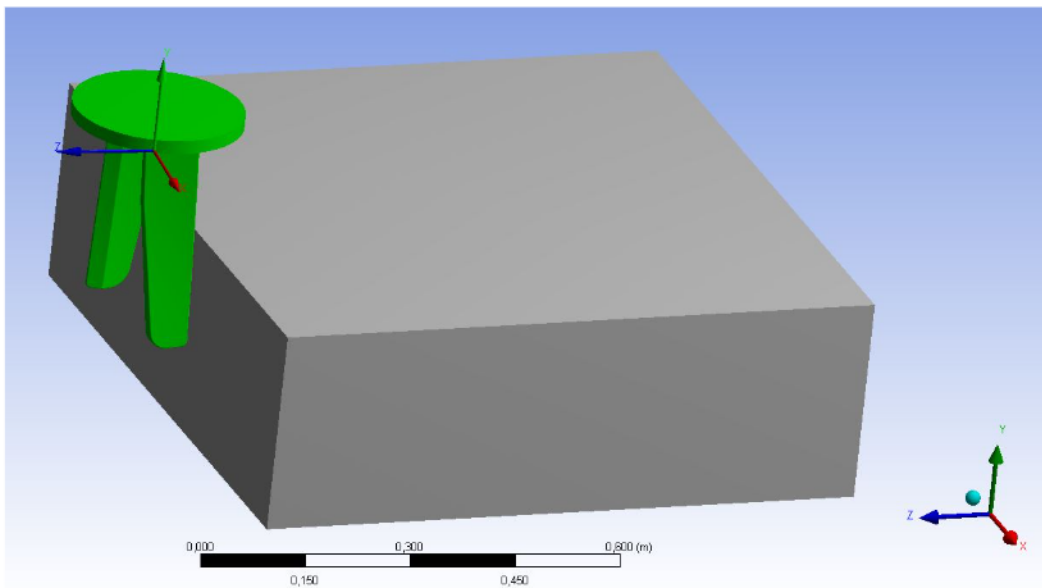

Figure 4. Initial geometry of the model.

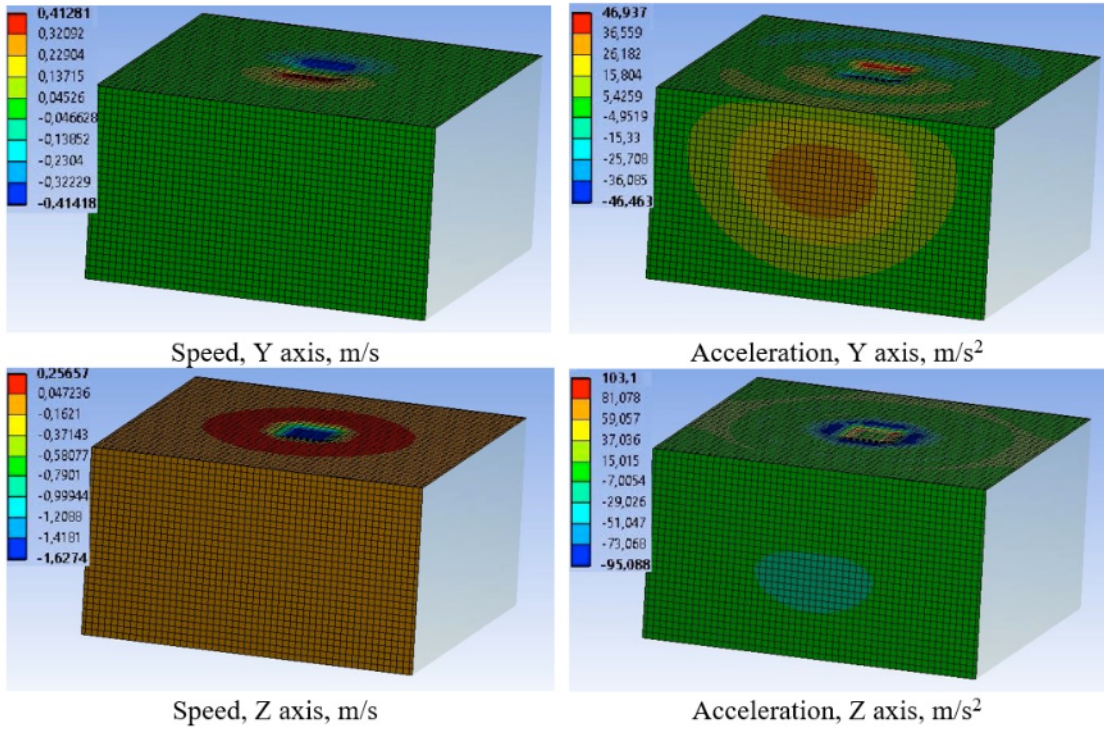

Figure 5. Speed and acceleration. Silty Sand, $t = 3$ ms.

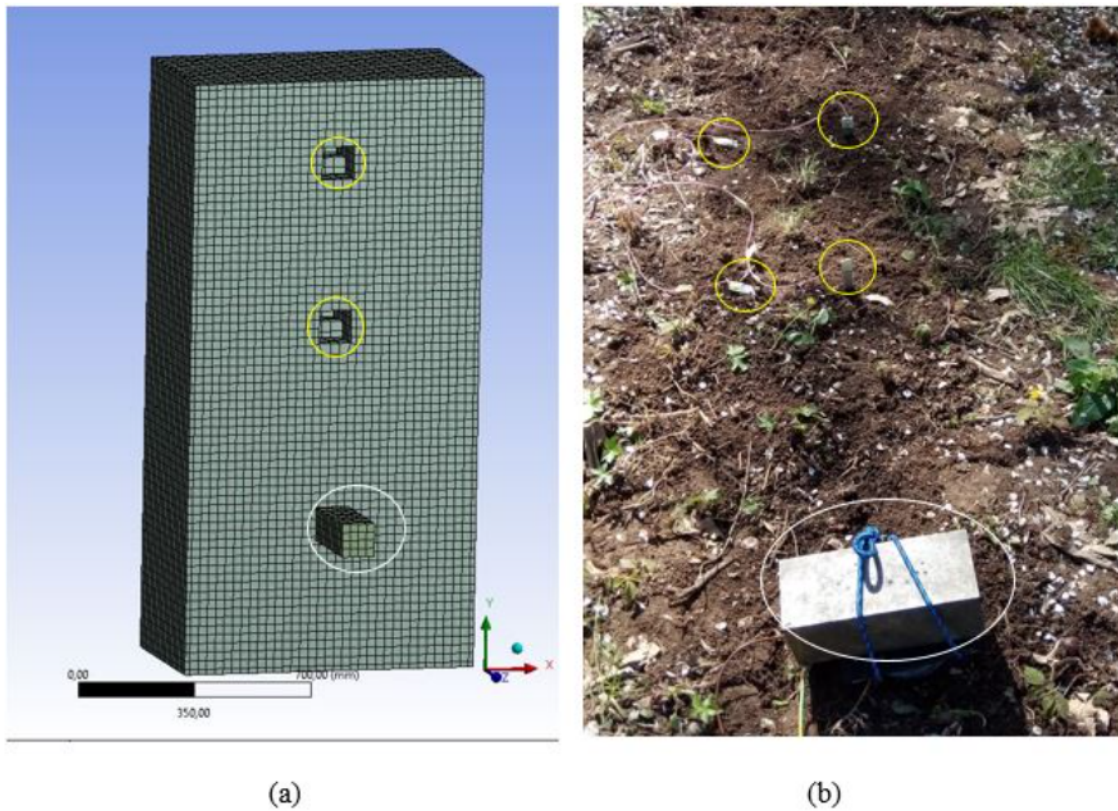

Figure 6. Model geometry for the study of the soil behavior. (a) the ANSYS model, (b) the field test. The yellow circles indicate the location of the sensors, and the white circles indicate the location of the body.

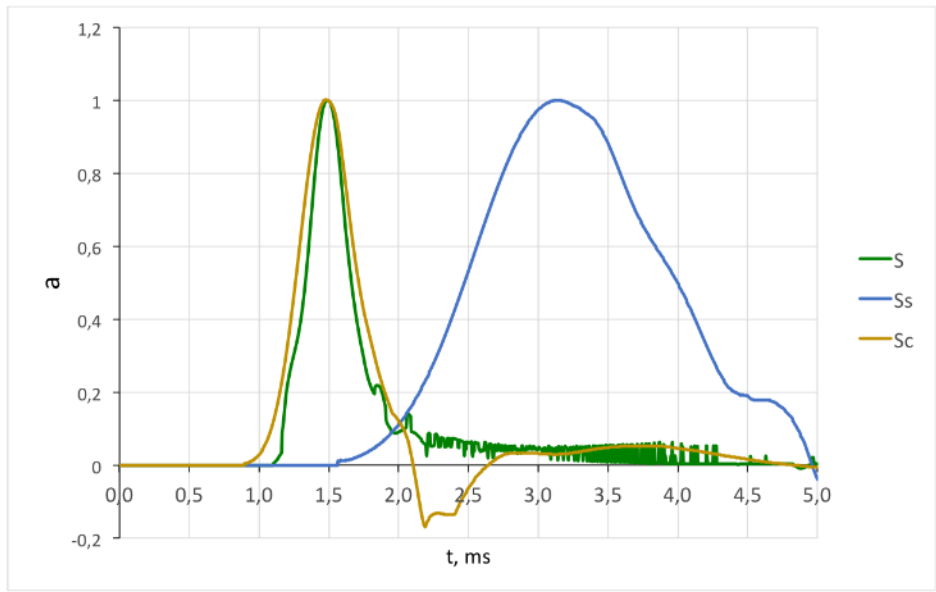

Figure 7. Acceleration for Sand (S), Silty Sand (Ss) and Sandy Clay (Sc).

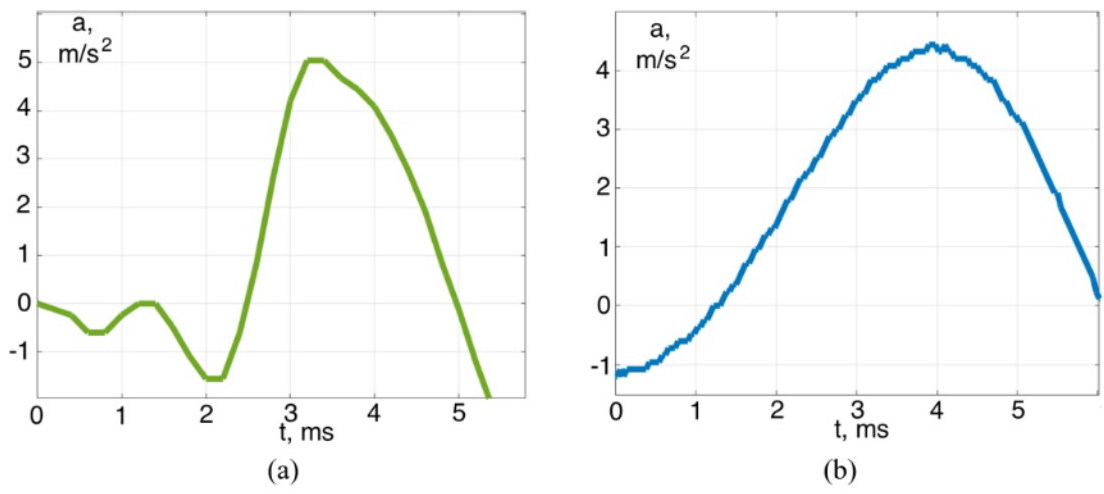

Figure 8. Experimental results of measurement of the acceleration a for Sand (a) and for Silty Soil (b).

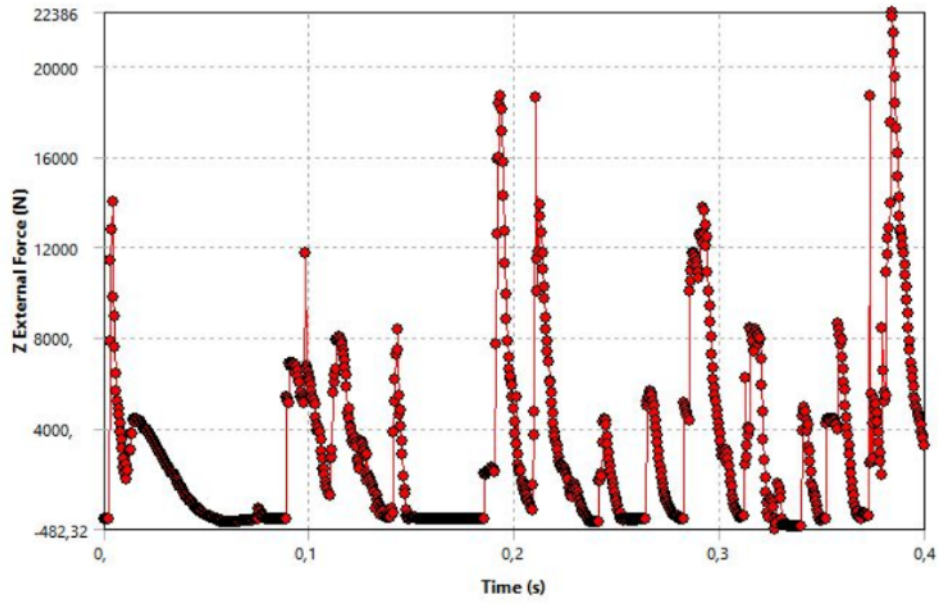

Figure 9. Force along the direction of displacement.

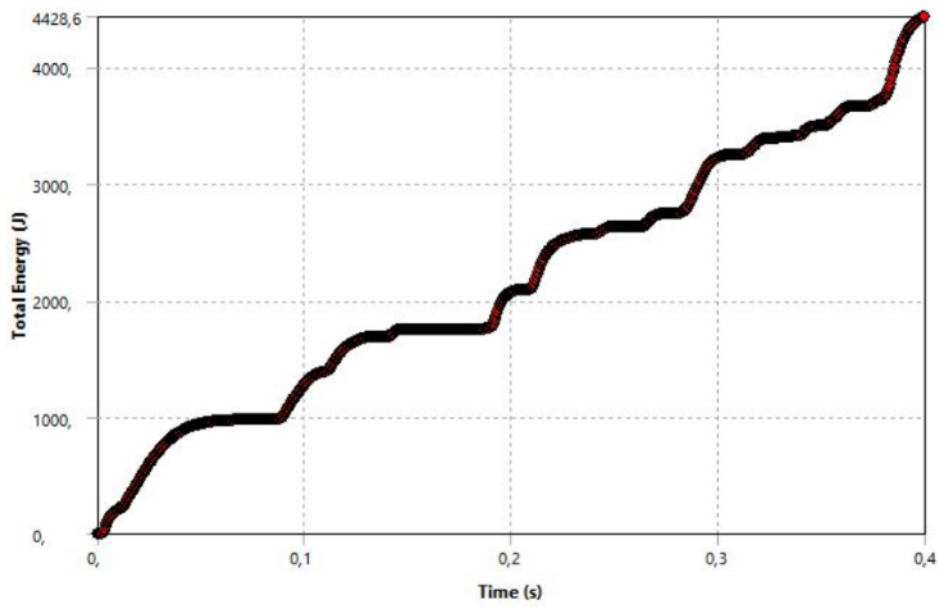

Figure 10. Energy for the work done.

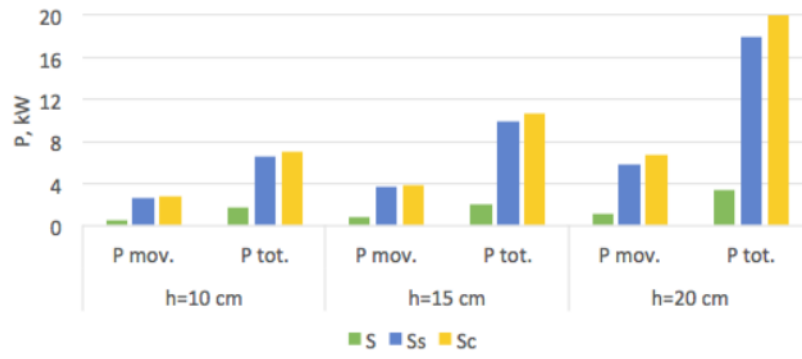

Figure 11. The average power for the three types of soil: Sand (S), Silty Sand (Ss) and Sandy Clay (Sc).

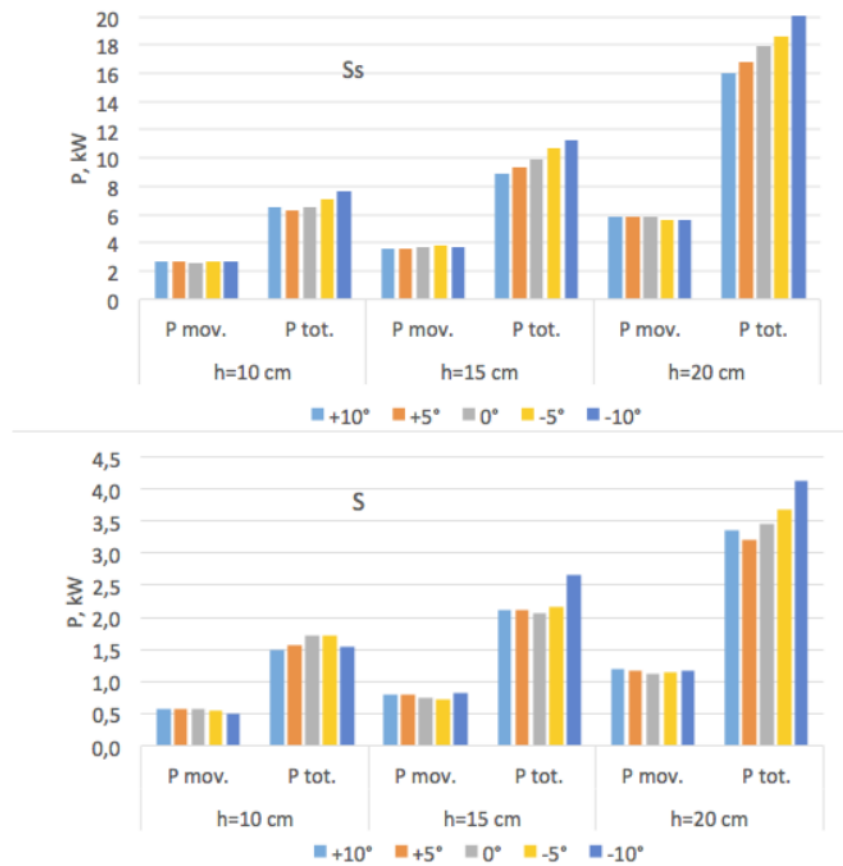

Figure 12. The average powers as a function of the angle of the tine for soil models of Silty Sand (Ss) and Sand (S).

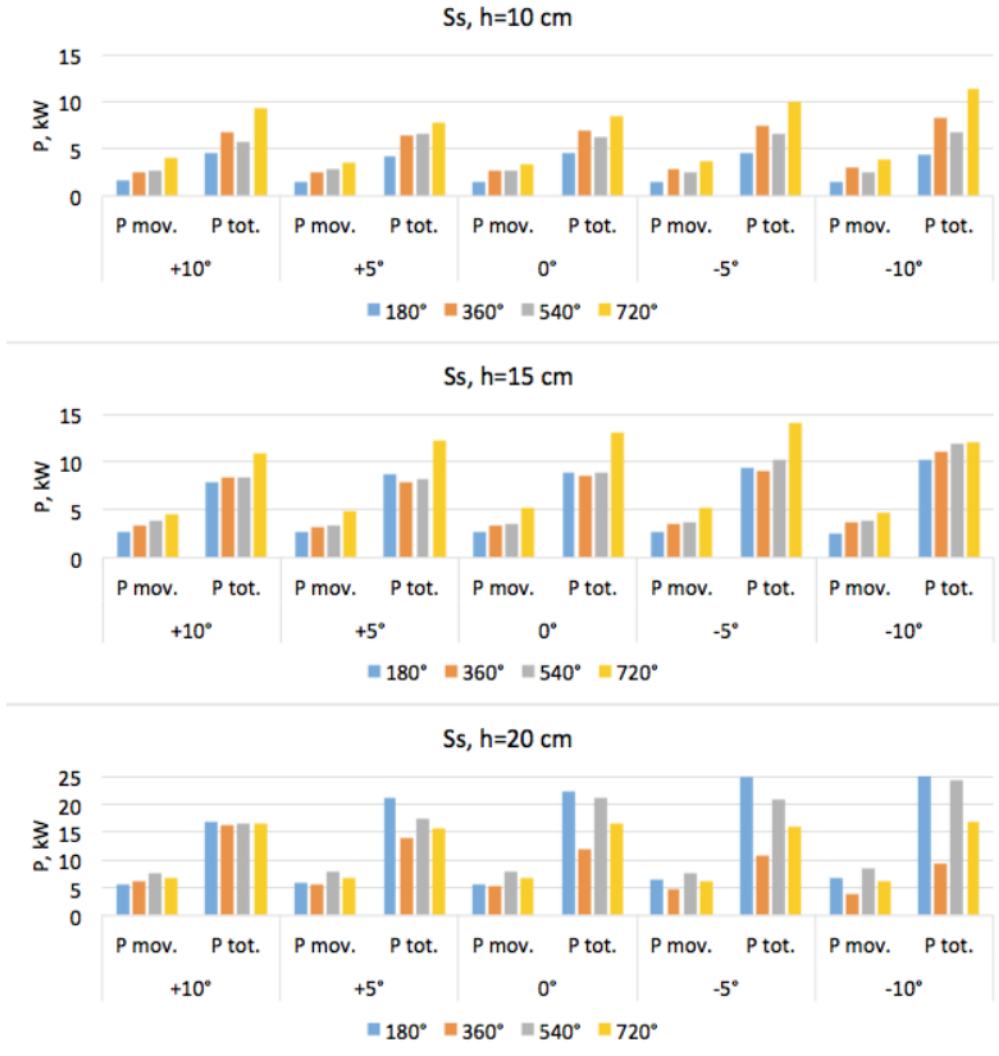

Figure 13. The average powers as a function of the angle of the tine for soil model of Silty Sand (Ss).

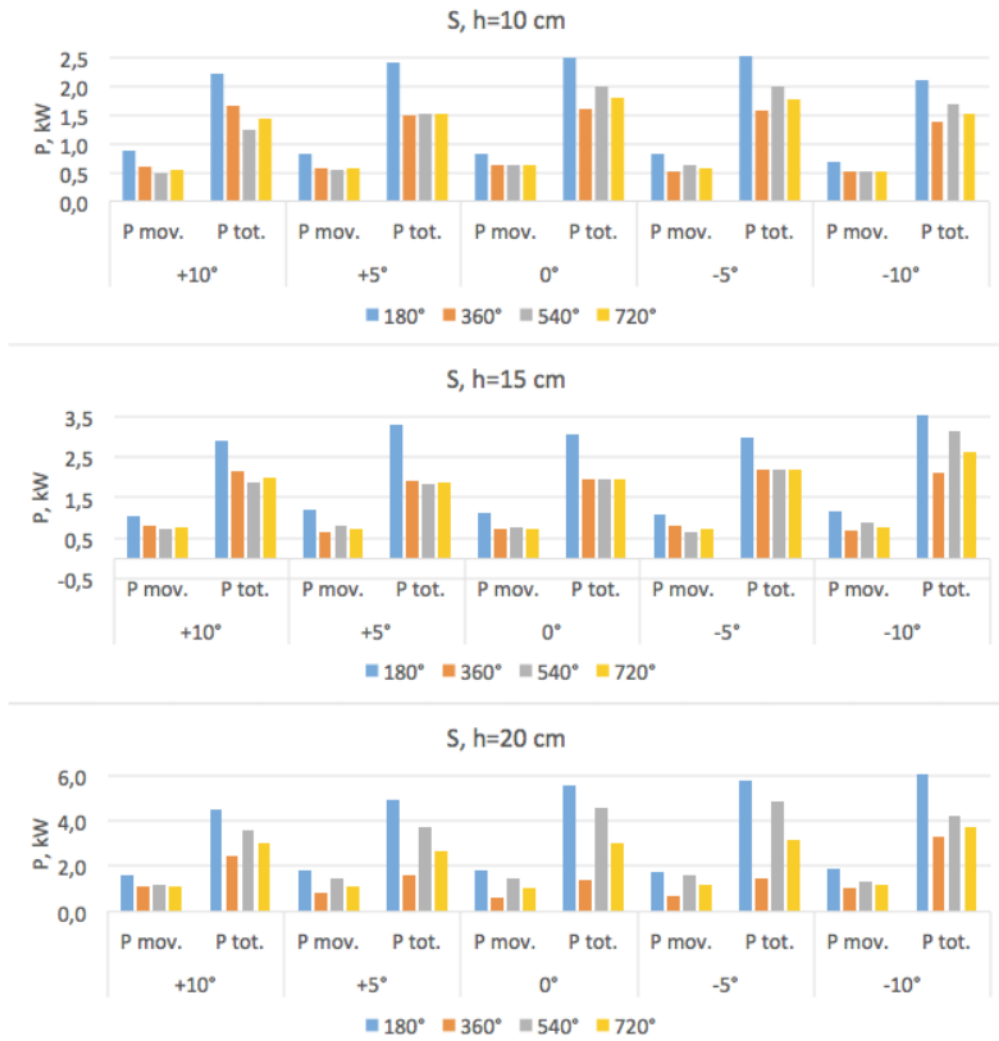

Figure 14. The average powers as a function of the angle of the tine for Sand soil model (S).