

Control of locomotion systems and dynamics in relative periodic orbits

*Original*

Control of locomotion systems and dynamics in relative periodic orbits / Fasso, F.; Passarella, S.; Zoppello, M.. - In: JOURNAL OF GEOMETRIC MECHANICS. - ISSN 1941-4889. - 12:3(2020), pp. 395-420. [10.3934/jgm.2020022]

*Availability:*

This version is available at: 11583/2865472 since: 2021-01-22T11:42:13Z

*Publisher:*

American Institute of Mathematical Sciences

*Published*

DOI:10.3934/jgm.2020022

*Terms of use:*

This article is made available under terms and conditions as specified in the corresponding bibliographic description in the repository

*Publisher copyright*

(Article begins on next page)



# Control of locomotion systems and dynamics in relative periodic orbits

Francesco Fassò, Simone Passarella, Marta Zoppello

► **To cite this version:**

Francesco Fassò, Simone Passarella, Marta Zoppello. Control of locomotion systems and dynamics in relative periodic orbits. 2020. hal-02546098v2

**HAL Id: hal-02546098**

**<https://hal.archives-ouvertes.fr/hal-02546098v2>**

Preprint submitted on 9 Jun 2020

**HAL** is a multi-disciplinary open access archive for the deposit and dissemination of scientific research documents, whether they are published or not. The documents may come from teaching and research institutions in France or abroad, or from public or private research centers.

L'archive ouverte pluridisciplinaire **HAL**, est destinée au dépôt et à la diffusion de documents scientifiques de niveau recherche, publiés ou non, émanant des établissements d'enseignement et de recherche français ou étrangers, des laboratoires publics ou privés.

# Control of locomotion systems and dynamics in relative periodic orbits

Francesco Fassò\*, Simone Passarella† and Marta Zoppello‡

(Version 3 — June 7, 2020)

*Dedicated to James Montaldi*

## Abstract

The connection between the dynamics in relative periodic orbits of vector fields with non-compact symmetry groups and periodic control for the class of control systems on Lie groups known as ‘(robotic) locomotion systems’ is well known, and has led to the identification of (geometric) phases. We take an approach which is complementary to the existing ones, advocating the relevance—for trajectory generation in these control systems—of the *qualitative* properties of the dynamics in relative periodic orbits. There are two particularly important features. One is that motions in relative periodic orbits of noncompact groups can only be of two types: either they are quasi-periodic, or they leave any compact set as  $t \rightarrow \pm\infty$  (‘drifting motions’). Moreover, in a given group, one of the two behaviours may be predominant. The second is that motions in a relative periodic orbit exhibit ‘spiralling’, ‘meandering’ behaviours, which are routinely detected in numerical integrations. Since a quantitative description of meandering behaviours for drifting motions appears to be missing, we provide it here for a class of Lie groups that includes those of interest in locomotion (semidirect products of a compact group and a normal vector space). We illustrate these ideas on some examples (a kinematic car robot, a planar swimmer).

*Keywords:* Robotic locomotion systems. Relative periodic orbits. Geometric phases. Reconstruction. Equivariant dynamics. Scallop theorem. Trajectory generation.  
*MSC:* 37N35, 37C80, 34H05, 70Q05, 70E60.

## 1 Introduction

**1.A. Aim of the paper.** This paper deals with trajectory generation for a class of driftless control systems on Lie groups known as *(robotic) locomotion systems*, from a dynamical system perspective.

The configuration space  $M$  of these systems is the product of an  $n$ -dimensional Lie group  $G$ , called the *position* or *group space*, and of an  $m$ -dimensional manifold  $S$  which is assumed to be parallelizable (e.g., an open set in an Euclidean space, or the product of one such set and a torus)

---

\*Università di Padova, Dipartimento di Matematica “Tullio Levi-Civita”, Via Trieste 63, 35121 Padova, Italy.  
(E-mail: [fasso@math.unipd.it](mailto:fasso@math.unipd.it))

†Università di Padova, Dipartimento di Matematica “Tullio Levi-Civita”, Via Trieste 63, 35121 Padova, Italy.  
(E-mail: [simone.passarella@math.unipd.it](mailto:simone.passarella@math.unipd.it))

‡Politecnico di Torino, Dipartimento di Scienze Matematiche, Corso Duca degli Abruzzi 24, 10129 Torino, Italy.  
(E-mail: [marta.zoppello@polito.it](mailto:marta.zoppello@polito.it))

called the *shape space*. If  $G$  is a matrix Lie group, then the governing equations for a given control  $t \mapsto s(t) \in S$  have the form

$$\dot{g} = g \sum_{i=1}^m \dot{s}_i(t) A_i(s(t)), \quad g \in G, \quad (1)$$

with maps  $A_i : S \rightarrow \mathfrak{g}$ , the Lie algebra of  $G$  (here, in writing  $\dot{s}_i$ , it is understood that an identification of  $TS$  with  $S \times \mathbb{R}^m$  has been chosen).

Systems of this type emerge in the locomotion of various types of robotics and living organisms. The literature on the subject is too extensive to be exhaustively accounted for, so we limit ourselves to a very limited (perhaps even almost random) choice which includes, besides some classics, some works which we perceive, at least under some respect, as closer to ours [43, 40, 42, 31, 38, 32, 13, 7, 34, 44]. The mathematical study of the control of these systems was initiated in the 1970's in the context of control systems on Lie groups [9, 30]. These control problems are also related to the theory of mechanical systems controlled through moving constraints, which was initiated around 1980 [4, 35] (see also [3] and references therein), where the control is achieved by assigning the evolution of some of the coordinates—here the shape  $s \in S$ . The literature on the controllability of systems of type (1) is very broad as well, so we limit ourselves to quote, in addition to the above pioneering works, the textbooks [10, 1, 6] where comprehensive informations can be found. Many of these studies do not take into account a cost functional, and following them we do the same here; indeed, for many locomotion systems, including the examples reported in this paper, the first question that arises is their controllability regardless the presence of a cost functional—namely if, given an initial and a final configuration, it is possible to find a control which drives the system between them.

Special attention has been devoted to control through *periodic* shape changes, which in this context are called *gaits* (see e.g. [31, 28]). Each  $T$ -periodic gait defines an element  $\gamma \in G$  such that each initial position  $g_0 \in G$  is changed, after the execution of the gait, to  $g_0\gamma$ . The group element  $\gamma$  is called the *phase*, or the *geometric phase*, associated to the considered gait [37, 31]. Its geometric origin—as holonomy of the connection  $\mathcal{A}$ —has been clarified and emphasized, see e.g. [37, 31, 6]. A certain attention has been given to the search of classes of ‘elementary’ gaits, that may produce a variety of planned motions [31], and to gaits optimization [5]. Geometric techniques to compute the phases are developed e.g. in [11].

Here, we take a somewhat different, complementary approach. Trajectory generation through periodic shape changes for system (1) is linked to reconstruction from a reduced periodic orbit of a  $G$ -invariant dynamical system on a trivial principal bundle  $\bar{M} \times G \rightarrow \bar{M}$ , with the action of  $G$  on  $\bar{M} \times G$  given by left translations on the factor  $G$ . (See e.g. [26, 28] for general introductions to equivariant dynamics). Indeed, assuming again that  $G$  is a matrix group, any such system has the form

$$\dot{\bar{m}} = \bar{X}(\bar{m}), \quad \dot{g} = g\mathcal{A}(\bar{m}) \quad (\bar{m}, g) \in \bar{M} \times G \quad (2)$$

with some map  $\mathcal{A} : \bar{M} \rightarrow \mathfrak{g}$  and some vector field  $\bar{X}$  on  $\bar{M}$ . If the ‘reduced’ system given by the vector field  $\bar{X}$  on  $\bar{M}$  has a periodic orbit  $t \mapsto \bar{m}(t)$ , then the set of all points in  $\bar{M} \times G$  that project onto it, which is diffeomorphic to  $S^1 \times G$ , is called a *relative periodic orbit* of system (2).

The dynamics in a relative periodic orbit is determined by the ‘reconstruction equation’  $\dot{g} = g\mathcal{A}(\bar{m}(t))$ , which is exactly of the form (1) if one takes  $\bar{M} = TS = S \times \mathbb{R}^m \ni (s, \dot{s})$  and  $\mathcal{A}(s, \dot{s}) = \sum_{i=1}^m \dot{s}_i A_i(s)$ . The difference between the two cases is that in the control case the periodic map  $t \mapsto \bar{m}(t)$  is assigned by the controller, but clearly, all results that apply to a relative periodic orbit apply to equation (1) with a periodic control as well. This analogy is well known in the control theory community. Nevertheless, it seems to us that the *qualitative* informations on control problems that may be drawn from this analogy have not yet been fully identified and exploited.

The description of the dynamics in a relative periodic orbit of an equivariant vector field is due to Krupa and Field [24, 33, 25] for compact groups and to Ashwin and Melbourne [2] for

noncompact groups (for further developments and some applications see also [29, 17, 15, 22, 18, 19] and references therein). Their results show that, in the case of a noncompact group, which is the one of interest in control theory, orbits in a relative periodic orbits may be of two types: either they remain inside a compact set, and in that case are quasi-periodic with a certain number  $k + 1$  of frequencies (namely, conjugate to a linear flow on  $\mathbb{T}^{k+1}$ ), with  $0 \leq k \leq \text{rank}(G)$ , or they ‘drift’ away leaving any compact set as  $t \rightarrow \pm\infty$ .

There are two features of the reconstruction process that, in our opinion, are relevant to trajectory generation, and are the focus of the present article.

The first is the fact that, for a given noncompact group, one of the two behaviours—either quasi-periodicity or drifting—may, in a sense that can be made precise, be “predominant” [2, 22]. For instance, among the groups that typically arise in the control of locomotion systems, quasi-periodicity is predominant for  $SE(2)$  while drifting is predominant for  $SE(3)$ . This may be relevant for trajectory generation with periodic controls: if the group is such that the predominant behavior is quasi-periodicity, then the choice of the periodic gait acquires an important role, because generic gaits will not produce a drift.

The second is the fact that motions in a relative periodic orbit exhibit ‘spiralling’, or ‘meandering’, behaviours. These behaviours are revealed in numerical integrations and have been investigated in a number of works, particularly oriented towards infinite dimensional systems and having many applications (see e.g. [2, 22, 23, 21, 20, 14] and references therein). In the case of quasiperiodic motions, the origin of these behaviours is clarified by the reconstruction procedure of Krupa and Field: one frequency is due to the periodicity of the gait in shape space, while the remaining  $k$  are produced by the action of a compact abelian subgroup of  $G$ , isomorphic to a torus. Instead, the group-theoretical origin of these behaviours does not seem to have been clarified in the case of drifting motions, perhaps because considered more or less self-evident in examples. We shall thus begin such an analysis here, by considering a class of Lie groups that contains the groups of interest in locomotion.

Specifically, we shall consider the case in which  $G$  is the semidirect product of a compact subgroup  $G_*$  and of a normal subgroup  $V$  isomorphic to a vector space,<sup>1</sup> which contains  $SE(n)$ . In such a case, the reduction can be performed in two stages, first under the normal subgroup  $V$  and then after the compact subgroup  $G_*$ . We will show that it is possible to consistently define as frequencies of the  $G$ -relative periodic orbit the frequencies of the  $G_*$ -relative periodic orbit, to which the theory of Krupa and Field applies. In particular, we show that the frequencies defined in this way coincide with those of the  $G$ -relative periodic orbit whenever the latter carries quasi-periodic motions. When instead the  $G$ -relative periodic orbit carries unbounded motions, then the action of  $G_*$  on  $V$  due to the semidirect product structure of the group translates the quasi-periodicity in  $G_*$  into spiralling, or meandering, patterns of the motion in the group  $G$ . The case of more general groups will be considered elsewhere.

We will illustrate these ideas on simple locomotion systems—a car robot and a microswimmer—for which  $G$  is  $SE(2)$ ,  $SE(2) \times S^1$ ,  $SE(3)$ .

**1.B Structure of the paper.** Section 2 is devoted to the qualitative properties of the dynamics in relative periodic orbits. We describe some known results, and present our new treatment of the frequencies of drifting motions for a class of semidirect products.

Section 3 is devoted to locomotion control systems. We focus on the case of periodic controls and its link with the dynamics in relative periodic orbits. We also give a detailed description of some properties of the phase for these systems. The material here is essentially known, but the presentation has some elements of novelty.

Section 4 is devoted to the examples. A short section of Conclusions follows.

---

<sup>1</sup>Equivalently, the semidirect product of a compact group  $G_*$  and of a vector space  $V$  on which  $G_*$  acts by linear maps.

In the Appendix we give a proof of the reconstruction result for quasi-periodic motions, which may help understanding the origin of the frequencies of the reconstructed motions.

**Acknowledgements.** The authors are grateful to Andrea Giacobbe, Paolo Rossi and Nicola Sansonetto for some very useful conversations on the topics of this article. FF has been partially supported by the MIUR-PRIN project 20178CJA2B *New Frontiers of Celestial Mechanics: theory and applications*. MZ gratefully acknowledges support from the MIUR grant *Dipartimenti di Eccellenza 2018-2022* (CUP: E11G18000350001).

## 2 The dynamics in a relative periodic orbit

**2.A Dynamical systems with symmetry.** Consider a free and proper action  $\Psi : G \times M \rightarrow M$  of a Lie group  $G$  on a manifold  $M$ . A vector field  $X$  on  $M$  is *equivariant* under the action  $\Psi$  if

$$X = \Psi_g^* X \quad \forall g \in G.$$

For general information on equivariant dynamics see e.g. [36, 26, 15, 28]. It is well known that the quotient manifold  $\bar{M} := M/G$  is a smooth manifold, the canonical projection  $\pi : M \rightarrow \bar{M}$  is a smooth submersion, and  $\pi : M \rightarrow \bar{M}$  is a principal  $G$ -bundle. We will assume that this bundle is trivial, so we may identify  $M$  with  $\bar{M} \times G \ni (\bar{m}, g)$ . From now on, thus, we take

$$M = \bar{M} \times G$$

and the action  $\Psi$  of  $G$  on  $\bar{M} \times G$  is by left translations in the factor  $G$ ,  $\Psi_h(\bar{m}, g) = (\bar{m}, hg)$ .

A vector field  $X$  on  $M = \bar{M} \times G$  which is equivariant under the action  $\Psi$  has the structure

$$X(\bar{m}, g) = (\bar{X}(\bar{m}), T_e L_g \cdot \xi(\bar{m}))$$

with  $\bar{X}$  a vector field on  $\bar{M}$  and  $\xi : \bar{M} \rightarrow \mathfrak{g}$  a smooth map. (As usual,  $\mathfrak{g}$  or  $\text{lie}(G)$  denotes the Lie algebra of  $G$  and  $L_g : G \rightarrow G$  denotes the left translation by  $g$  in  $G$ , namely  $L_g h = gh$  for all  $h \in G$ ). Thus, its dynamics is given by the system of differential equations

$$\dot{\bar{m}} = \bar{X}(\bar{m}), \quad \dot{g} = T_e L_g \cdot \xi(\bar{m}) \quad (3)$$

on  $\bar{M} \times G$ . The first equation is the reduced equation and the second is the reconstruction equation. If  $G$  is a matrix group, the latter takes the form  $\dot{g} = g \xi(\bar{m})$  with  $\xi(\bar{m})$  now a matrix in  $\mathfrak{g} \subset L(n)$ , the space of all  $n \times n$  real matrices.

Assume that, for a given point  $m_0 = (\bar{m}_0, g_0)$  in  $\bar{M} \times G$ , the integral curve  $t \mapsto \bar{m}(t)$  of the reduced equation with initial datum  $\bar{m}(0) = \pi(m_0) = \bar{m}_0$  is known. The determination of the solution  $t \mapsto m(t)$  of system (3) with initial datum  $m_0$  reduces to the determination of the solution of the reconstruction equation

$$\dot{g}(t) = T_e L_{g(t)} \cdot \xi(\bar{m}(t)) \quad (4)$$

with initial datum  $g_0$ .

The qualitative properties of the solutions of the reconstruction equation (4) have been studied in the case of relative equilibria ( $t \mapsto \bar{m}(t)$  is constant) and of relative periodic orbits ( $t \mapsto \bar{m}(t)$  is periodic). We are interested in the latter case.

**2.B Relative periodic orbits.** Assume that the reduced equation  $\dot{\bar{m}} = \bar{X}(\bar{m})$  in  $\bar{M}$  has a periodic solution  $t \mapsto \bar{m}(t)$  of minimal period  $T > 0$ . Let  $\bar{R} := \bar{m}(\mathbb{R}) \subset \bar{M}$  be its image. Then, the preimage

$$P := \pi^{-1}(\bar{R}) = \bar{R} \times G$$

of  $\bar{R}$  under the projection  $\pi : \bar{M} \times G \rightarrow \bar{M}$ ,  $\pi(\bar{m}, g) = \bar{m}$ , is called a *relative periodic orbit*.

Consider an integral curve  $t \mapsto (\bar{m}(t), \mathcal{G}(t)) \in P$  of (3) with initial datum  $(\bar{m}_0, e) \in P$ . Such an integral curve intersects the  $G$ -orbit through  $(\bar{m}_0, e)$  at every period  $T$ , at the points  $(\bar{m}_0, \mathcal{G}(pT))$ ,  $p \in \mathbb{Z}$ . The *phase of the relative periodic orbit*  $P$  (relative to the point  $\bar{m}_0$ ) is the group element

$$\gamma := \mathcal{G}(T)$$

(other names are geometric phase, shift, monodromy). By the periodicity of the reduced motion and the  $G$ -invariance of the system,  $\mathcal{G}(pT) = \gamma^p$  and the integral curve intersects the  $G$ -orbit  $\{\bar{m}_0\} \times G \subset P$  at the points  $(\bar{m}_0, \gamma^p)$ ,  $p \in \mathbb{Z}$ .

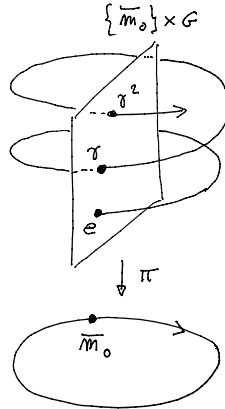

Figure 1: The phase

For any  $g \in G$ , the *subgroup of  $G$  generated by  $g$*  is the closed, abelian subgroup  $H(g)$  of  $G$  defined as

$$H(g) := \overline{\{g^p : p \in \mathbb{Z}\}},$$

where the bar denotes the topological closure. If  $G$  is not compact, then the reconstruction theory of [33, 25, 2] shows that the qualitative properties of the integral curves of  $X$  in the relative periodic orbit depend to a large extent on whether the subgroup  $H(\gamma)$  generated by the phase  $\gamma$  is compact or not:<sup>2</sup>

- i. If  $H(\gamma)$  is compact, then the flow of  $X$  in  $P$  is quasi-periodic with  $k + 1$  frequencies for some  $k \leq \text{rank}(G) + 1$ .
- ii. If  $H(\gamma)$  is not compact, then the integral curves of  $X$  leave any compact subset of  $P$  as  $t \rightarrow \pm\infty$  [2, 15].

We call ‘quasi-periodic’ the motions in case i. and ‘drifting’ those in case ii. Greater details on them are given in the next two Sections.

*Remark:* The phase defined above depends on the choice of the initial point  $(\bar{m}_0, e)$ . The integral curve of (3) with initial datum  $(\bar{m}_0, g_0)$  is  $t \mapsto (\bar{m}(t), g_0 \mathcal{G}(t))$  and has phase  $g_0 \mathcal{G}(T) g_0^{-1}$ . Given any  $t_0 \neq 0$ , the  $X$ -orbit of  $(\bar{m}(t_0), e)$  intersects the  $G$ -orbit  $\pi^{-1}(\bar{m}(t_0))$  at the points  $\mathcal{G}(t_0 + pT) = \mathcal{G}(t_0) \mathcal{G}(T)^p$ , and has phase  $\mathcal{G}(t_0) \mathcal{G}(T) \mathcal{G}(t_0)^{-1}$ . Thus, properly speaking, the phase of a relative periodic orbit is a conjugacy class of  $G$ . All the relevant properties of the phases are common to all phases in a conjugacy class.

<sup>2</sup>A compact, connected, abelian subgroup of a Lie group  $G$  is called a *torus* of  $G$ , and is diffeomorphic to  $\mathbb{T}^k$  for some  $k$ . The maximal dimension of its tori is the *rank* of a Lie group. Thus, for instance,  $SE(2)$  and  $SE(3)$  have both rank one.

**2.B Quasi-periodic motions.** In case i., the relative periodic orbit is foliated by ‘invariant tori’  $\mathcal{T}_g$ ,  $g \in G$ . These are  $X$ -invariant submanifolds diffeomorphic to  $\mathbb{T}^{k+1} = S^1 \times \mathbb{T}^k \ni (\langle \alpha_0 \rangle, \langle \alpha \rangle)$ ,<sup>3</sup> and the restriction of the dynamics to each one of them is conjugate to the linear flow

$$(t, (\langle \alpha_0 \rangle, \langle \alpha \rangle)) \mapsto (\langle \alpha_0 + \omega_0 t \rangle, \langle \alpha + \omega t \rangle) \quad (5)$$

on  $S^1 \times \mathbb{T}^k$ . Here,  $\omega_0 = 2\pi/T$  is the frequency of the reduced periodic orbit and  $\omega = (\omega_1, \dots, \omega_k) \in \mathbb{R}^k$  is a vector determined by the phase. Thus, all motions in  $P$  have the same frequencies  $\omega_0, \dots, \omega_k$ . For completeness, we give a precise statement and a proof of this fact in the Appendix, even though under a simplifying assumption. The proof fully explains the origin of the frequencies  $\omega_1, \dots, \omega_k$ , but to make the article independent of it, we quickly introduce these frequencies here.

To keep things simple, assume that there exists an element  $\eta$  in the Lie algebra  $\mathfrak{g}$  of  $G$  such that

$$\gamma = \exp(T\eta) \quad (6)$$

(this certainly happens if the exponential map of  $G$  is surjective, as in the case of  $SE(n)$ ). This element generates the closed, abelian, connected subgroup

$$K(\eta) := \overline{\{\exp(t\eta) : t \in \mathbb{R}\}} \quad (7)$$

of  $G$ , where the bar denotes the topological closure. Being closed, the subgroup  $K(\eta)$  is a Lie subgroup of  $G$ . Clearly  $H(\gamma) \subseteq K(\eta)$ , and it is not difficult to see that  $K(\eta)$  is compact if and only if  $H(\gamma)$  is compact. (One implication is obvious. For the other, note that the curve  $t \mapsto \exp(t\eta)$  intersects  $K(\eta)$  at the times  $qT$ ,  $q \in \mathbb{Z}$ , and use the compactness of  $H(\gamma)$  and of the intervals  $[(q-1)T, qT]$ ).

Therefore, if  $H(\gamma)$  is compact, then  $K(\eta)$  is a torus of  $G$  of some dimension  $k$ ,  $0 \leq k \leq \text{rank}(G)$ . We will denote by  $\text{lie}(K(\eta))$ ,  $e_{K(\eta)}$ ,  $\exp_{K(\eta)}$  etc. the Lie algebra, the identity element, the exponential map etc. of  $K(\eta)$  (and we will use below a similar notation for other groups). Choosing a basis of  $\text{lie}(K(\eta))$  formed by vectors  $\xi^1, \dots, \xi^k$  which after multiplication by  $2\pi$  generate  $\ker(\exp_{K(\eta)})$  (namely,  $\exp_{K(\eta)}(\xi) = e_{K(\eta)}$  if and only if  $\xi = \sum_j 2\pi c_j \xi^j$  with all  $c_j \in \mathbb{Z}$ ) gives a diffeomorphism  $\langle \alpha \rangle \mapsto \exp_{K(\eta)}(\sum_{i=1}^k \alpha_i \xi^i)$  of  $\mathbb{T}^k$  to  $K(\eta)$ . The frequencies  $\omega_1, \dots, \omega_k$  of motions (5) are the components of the Lie algebra vector  $\eta$  in the chosen basis:

$$\eta = \sum_{i=1}^k \omega_i \xi_i. \quad (8)$$

Clearly, motions in  $P$  exhibit spiralling, or ‘meandering’, paths produced by the embedding in  $P$  of the spirals (5) in  $\mathbb{T}^{k+1}$ . (The embedding is built in the Appendix).

*Remarks:* (i) If only  $p < k+1$  of the frequencies are nonresonant (namely, linearly independent over  $\mathbb{Q}$ ), then the closure of each motion (5) is a  $p$ -dimensional torus. In such a situation, the construction described above could be repeated with  $K(\eta)$  replaced by a torus of dimension  $p-1$  (see [2, 15] and, for an analogous case, [18]). In this way,  $p$ -dimensional ‘invariant tori’  $\mathcal{T}_g$  are constructed that are minimal sets for the flow of  $X$ .

(ii) The choice of the ‘logarithm’  $\eta$  of the phase is unique up to an element of  $\ker(\exp_{K(\eta)})$ . Even though this choice does not affect the phase, it may change the dimension of  $K(\eta)$  (an example will be met in Section 4.C).

(iii) Even if the dimension of  $K(\eta)$  is kept fixed, the indeterminacy of  $\eta$  and of the basis of  $\text{lie}(K(\eta))$  implies that the frequency vector  $\omega = (\omega_1, \dots, \omega_k)$  is determined up to an automorphism of  $\mathbb{Z}^k$  (a linear transformation with integer entries and determinant  $\pm 1$ ).

<sup>3</sup>For  $x \in \mathbb{R}$ , we write  $\langle x \rangle$  to mean  $x \pmod{2\pi}$ .



**2.D Frequencies of drifting motions for certain semidirect products.** The description of drifting motions in a relative periodic orbit  $\bar{R} \times G$  is less detailed than that of quasi-periodic motions. As already mentioned, their  $G$ -component leaves any compact set of  $G$  as  $t \rightarrow \pm\infty$  (and this is basically their known dynamical characterization).

To show that this is indeed the case note that, if  $H(\gamma)$  is not compact, then certainly the points  $\mathcal{G}(nT) = \gamma^n$  leave any preassigned compact subset of  $G$  for  $n$  tending to at least one between  $\pm\infty$ . Assume, e.g., that this happens for  $n \rightarrow +\infty$ . Since the action of  $G$  on itself by left translations is proper, the map  $f : G \times G \rightarrow G \times G$ ,  $(g, h) \mapsto (gh, h)$  is proper. If the points  $\gamma^{-n}$ ,  $n > 0$ , remain inside a compact subset of  $G$ , then the subset  $f^{-1}(\{(e, \gamma^{-n}) : n \in \mathbb{Z}_+\}) = \{(\gamma^n, \gamma^{-n}) : n \in \mathbb{Z}_+\}$  of  $G \times G$  is compact, against the hypothesis that the  $\gamma^n$ 's leave any compact set in  $G$ .

The possibility of defining frequencies and spiralling for drifting motions does not seem to have been considered before (even though frequencies make, at least implicitly, their appearance in some examples involving  $SE(2)$  or other simple groups [2, 22]). We leave a general analysis of this topic for a future work and, as a first step in this direction, we restrict our attention to a family of Lie groups including  $SE(n)$  and other common groups in locomotion.

Specifically, in this Section we assume that  $G$  is the semidirect product of a compact subgroup  $G_*$  and of a (normal) vector subgroup  $V$ :

$$G = G_* \ltimes V$$

(a “vector subgroup” of a Lie group is a closed subgroup isomorphic to a vector space). As a manifold,  $G$  is diffeomorphic to  $G_* \times V$ , but the group multiplication is

$$(g_*, u)(h_*, v) = (g_*h_*, u\phi_{g_*}(v))$$

where  $\phi : G_* \times V \rightarrow V$  is a (left) action of  $G_*$  on  $V$  such that, for each  $g_* \in G_*$ ,  $\phi_{g_*}$  is an automorphism of  $V$ . We will identify  $G$  with the product  $G_* \times V$  and write any element  $g \in G$  as  $(g_*, u)$  with unique  $g_* \in G_*$  and  $u \in V$ . Correspondingly, we will identify the phase space  $M = \bar{M} \times G \ni (\bar{m}, g)$  with

$$M_0 := \bar{M} \times G_* \times V$$

so that the action of  $G$  on  $M$  becomes the action of  $G_* \times V$  on  $M_0$  given by

$$\Psi_{(g_*, u)}(\bar{m}, h_*, v) = (\bar{m}, L_{g_*}h_*, (L_u \circ \phi_{g_*})(v)).$$

The Lie algebra  $\mathfrak{g}$  of  $G$ , as a vector space, is the direct sum of the Lie algebras  $\text{lie}(G_*)$  of  $G_*$  and  $\text{lie}(V)$  of  $V$ , and any  $\xi \in \mathfrak{g}$  can thus be uniquely written as  $(\xi_*, \xi_V)$  with  $\xi_* \in \text{lie}(G_*)$  and  $\xi_V \in \text{lie}(V)$ . We will denote by  $e_G$ ,  $e_*$  and  $e_V$  the identity elements of  $G$ ,  $G_*$  and  $V$ , and similarly write  $\exp_G$ ,  $\exp_{G_*}$ ,  $\exp_V$  etc.

In order to define frequencies for the drifting motions we use the fact that, for a semidirect product, the reduction procedure under  $G$  can be performed in two stages: first under the normal subgroup  $V$ , then under  $G_*$ . Indeed, it is immediate to check that a  $G$ -invariant vector field  $X$  on  $M_0 \ni (\bar{m}, g_*, u)$  has the form

$$\dot{\bar{m}} = \bar{X}(\bar{m}), \quad \dot{g}_* = T_e L_{g_*} \cdot \xi_*(\bar{m}), \quad \dot{u} = T_e(L_u \circ \phi_{g_*}) \cdot \xi_V(\bar{m}) \quad (9)$$

with  $\bar{X}$  a vector field on  $\bar{M}$  and, for any  $\bar{m} \in \bar{M}$ ,  $\xi_*(\bar{m}) \in \text{lie}(G_*)$  and  $\xi_V(\bar{m}) \in \text{lie}(V)$ . In agreement with the fact that  $V$  is normal, the quotient  $G/V$  is a group isomorphic to  $G_*$  and the quotient projection  $G \rightarrow G_*$  is a Lie group isomorphism. Hence, taking the quotient under  $V$  gives a “first-reduced” system on the phase space  $M_1 := \bar{M} \times G_*$ , with quotient map  $\pi_1 : M_0 \rightarrow M_1$  given by the projection  $\pi_1(\bar{m}, g_*, u) = (\bar{m}, g_*)$ . The first-reduced vector field  $\bar{X}_1$  on  $\bar{M} \times G_*$ , as a differential equation, is

$$\dot{\bar{m}} = \bar{X}(\bar{m}), \quad \dot{g}_* = T_e L_{g_*} \cdot \xi_*(\bar{m})$$

and is  $G_*$ -invariant. Its reduction under the action  $(g_*, (\bar{m}, h_*)) = (\bar{m}, L_{g_*} h_*)$  of  $G_*$  on  $M_1$  gives the vector field  $\bar{X}$  on  $\bar{M}$ , and coincides with the reduction of the full system from  $M_0$  to  $M_2 := \bar{M}$  under the action of  $G$ . If  $\pi_2 : M_1 \rightarrow M_2$  and  $\pi : M_0 \rightarrow M_2$  are the projections associated to these two other quotients, then  $\pi = \pi_2 \circ \pi_1$ .

Consider now a reduced periodic orbit  $\bar{R} \subset M_2$  of period  $T$ . Reconstructing it with the full  $G$ -action gives a  $G$ -relative periodic orbit  $P_0 = \pi^{-1}(\bar{R}) \subset M_0$  with a certain phase  $\gamma = (\gamma_*, \gamma_V) \in G$ . Since  $\gamma^{n+1} = (\gamma_*^{n+1}, \gamma_V \phi_{\gamma_*}(\gamma_V)^n)$  for all  $n \geq 1$ , the compactness of the subgroup  $H(\gamma) := \{\gamma^n : n \in \mathbb{Z}\}$  of  $G$  generated by  $\gamma$  depends jointly on the two components  $\gamma_* \in G_*$  and  $\gamma_V \in V$  of the phase; for  $H(\gamma)$  to be noncompact it is obviously necessary that  $\gamma_V \neq e_V$ , but this is not sufficient; for some examples, see Sections 2.E and 4. On the other hand, reconstructing  $\bar{R}$  with the action of  $G_*$  produces a  $G_*$ -relative periodic orbit  $P_1 = \pi_2^{-1}(\bar{R}) \subset M_1$ .

**Lemma 1.** *The phase of  $P_1$  coincides with the  $G_*$ -component of the phase of  $P$ .*

*Proof.* From the fact that the vector field  $X$  is  $\pi_1$ -related to the vector field  $X_1$  in  $P_1$  it follows that  $\pi_1 \circ \Phi_T^X = \Phi_T^{X_1} \circ \pi_1$  and therefore  $\Phi_T^{X_1}(\bar{m}_0, e_*) = \Phi_T^X \circ \pi_1(\bar{m}_0, e_*, e_V) = \pi_1 \circ \Phi_T^X(\bar{m}_0, e_*, e_V) = \pi_1(\bar{m}_0, \gamma_*, w) = (\bar{m}_0, \gamma_*)$ .  $\square$

Thus, if  $\gamma = (\gamma_*, \gamma_V)$  is the phase of  $P$ ,  $\gamma_*$  is the phase of  $P_1$ . Since  $G_*$  is compact, the subgroup  $H_*(\gamma_*) := \{\gamma_*^n : n \in \mathbb{Z}\}$  of  $G_*$  generated by  $\gamma_*$  is compact. Therefore, the dynamics in  $P_1$  is quasiperiodic, and has a set of frequencies  $(\omega_0, \omega) \in \mathbb{R} \times \mathbb{R}^k$ , for some  $0 \leq k \leq \text{rank}(G_*)$ , with  $\omega_0 = 2\pi/T$  and a vector  $\omega \in \mathbb{R}^k$  which is unique up to an automorphism of  $\mathbb{Z}^k$ .

**Definition 1.** *Under the hypotheses of this section, we define as frequencies of the  $G$ -relative periodic orbit  $P$  the frequencies of the  $G_*$ -relative periodic orbit  $P_1$ .*

This definition applies to both compact and noncompact subgroups  $H(\gamma) \subset G$ , namely to both quasi-periodic and drifting motions in the  $G$ -relative periodic orbit  $P$ . Even though the case of interest is that of drifting motions, we note that, in the case of quasi-periodic motions, this definition leads to the right frequencies.

**Proposition 1.** *In the hypotheses of this section, assume that  $H(\gamma)$  is compact. Then, the reconstruction procedures described in Section 2.C for the  $G$ -action and for the  $G_*$ -action can be performed so as to produce the same frequencies.*

*Proof.* We use a few elementary facts about Lie groups, which can be found in any textbook (e.g. [8, 16]).

Under the current hypotheses, as a manifold,  $G$  can be identified with  $G_* \times V$  and, as a vector space,  $\text{lie}(G) := \mathfrak{g}$  is isomorphic to  $\text{lie}(G_*) \oplus \text{lie}(V)$ . We thus write  $g = (g_*, g_V) \in G_* \times V$  the elements of  $G$  and  $\xi = (\xi_*, \xi_V) \in \text{lie}(G_*) \times \text{lie}(V)$  those of  $\text{lie}(G) := \mathfrak{g}$ . Let  $p_1 : G_* \times V \rightarrow G_*$ ,  $p_1(g_*, u) = g_*$ , be the projection onto the first factor. Because of the semidirect product structure of  $G = G_* \ltimes V$ , as a map from  $G$  to  $G_*$  the projection  $p_1$  is a Lie group homomorphism. Therefore, its differential  $T_{e_G} p_1 : \text{lie}(G_*) \times \text{lie}(V) \rightarrow \text{lie}(G_*)$ ,  $(\xi_*, \xi_V) \mapsto \xi_*$ , as a map from  $\text{lie}(G)$  to  $\text{lie}(G_*)$ , is a Lie algebra homomorphism. Hence,  $p_1 \circ \exp_G = \exp_{G_*} \circ T_{e_G} p_1$ .

If  $\gamma = (\gamma_*, \gamma_V)$  is the phase of  $P$  then, as already noticed,  $\gamma_*$  is the phase of  $P_1$ . Pick up an  $\eta = (\eta_*, \eta_V) \in \text{lie}(G)$  such that  $\gamma = \exp_G(T\eta)$ . Then,  $\gamma_* = p_1 \circ \exp_G(\eta) = \exp_{G_*}(\eta_*)$ .

Consider now the two subgroups  $K := \exp_G(\mathbb{R}\eta)$  of  $G$  and  $K_* := \exp_{G_*}(\mathbb{R}\eta_*)$  of  $G_*$ , which are both tori. From the relationship between  $p_1$  and  $T_e p_1$ , using also the compactness of  $K$  and the continuity of  $p_1$ , it follows that

$$K_* = p_1(K).$$

Hence  $\dim K_* \leq \dim K$ . We now show that  $\dim K_* = \dim K$ .

Let  $k = \dim K$ . Since  $p_1 : K \rightarrow K_*$  is a group homomorphism,  $\text{lie}(K_*) = T_e p_1(\text{lie}(K))$ . Since  $K$  is a  $k$ -dimensional torus, its Lie algebra has a basis  $\{\xi^1, \dots, \xi^k\}$  which generates  $\ker(\exp_K)$ .

Write, as above,  $\xi^i = (\xi_*^i, \xi_V^i)$ . The vectors  $\xi_*^i = T_{ep_1} \cdot \xi^i$  belong to  $\text{lie}(K_*)$  and so, if they are linearly independent,  $\dim K_* = k$ . If they are not linearly independent then, possibly after a reordering,  $\xi_*^k = \sum_{i=1}^{k-1} c_i \xi_*^i$  with  $c_i \in \mathbb{R}$ . Hence  $\xi^k - \sum_{i=1}^{k-1} c_i \xi^i = (0, w) \in \text{lie}(K)$  with some nonzero (in view of the linear independence of  $\xi^1, \dots, \xi^k$ ) vector  $w \in \text{lie}(V)$ . Note now that  $\exp_K(t(0, w)) = (e_{G_*}, \exp_V(tw))$  for all  $t \in \mathbb{R}$  and thus

$$\overline{\exp_K(\mathbb{R}(0, w))} = \{e_{G_*}\} \times \overline{\exp_V(\mathbb{R}w)}.$$

But this is impossible because  $\overline{\exp_K(\mathbb{R}(0, w))}$ , being a closed subgroup of the compact group  $K$ , is compact, while  $\overline{\exp_V(\mathbb{R}w)}$  is noncompact because the vector subgroup  $V$  contains no nontrivial compact subgroups. Thus, by contradiction,  $\dim(K_*) = \dim(K)$ . Moreover,  $\{\xi_*^1, \dots, \xi_*^k\}$  is a basis of  $\text{lie}(K_*)$  that exponentiate to the identity.

As explained in Section 2.C, the choice of the basis  $\{\xi^1, \dots, \xi^k\}$  of  $\text{lie}(K)$  and of the ‘logarithm’  $\eta = \sum_i \omega_i \xi^i$  of the phase  $\gamma = (\gamma_*, \gamma_V)$  leads to the frequencies  $\omega_0, \omega_1, \dots, \omega_k$  of the  $G$ -relative periodic orbit  $P$ . In the basis  $\{\xi_*^1, \dots, \xi_*^k\}$  of  $\text{lie}(K_*)$ , the phase  $\gamma_*$  of the  $G_*$ -relative periodic orbit  $P_1$  has ‘logarithm’  $\eta_* = T_{ep_1} \cdot \eta = \sum_i \omega_i \xi_*^i$  which leads to the same frequencies.  $\square$

Definition 1 allows to attach a set of  $k + 1$  frequencies to drifting motions, with some  $0 \leq k \leq \text{rank}(G_*)$ . One of these frequencies comes from the reduced period, while the remaining  $k$  are produced from the reconstruction procedure of the reduced periodic orbit with the action of  $G_*$ . In the identification (as a manifold) of the  $G$ -relative periodic orbit  $P$  with  $\bar{R} \times G_* \times V$ ,  $(\omega_0, \omega)$  are the frequencies of the projections of motions to the  $\bar{R} \times G_*$  factor of  $P$ , which are quasi-periodic.

However, due to the semidirect product structure of the group, which couples the  $V$ -component of motions to their  $G_*$ -component, the frequencies may affect also the evolution of the  $V$ -component of motions, producing meandering behaviours. In practice, the observability of these frequencies and meandering depends on the possibility of identifying the components  $\bar{R} \times G_*$  and  $V$  of the relative periodic orbit in the system’s phase space. We will illustrate this situation in the examples—from control theory—of Section 4.

*Remarks:* (i) While the quasiperiodicity or drifting of a motion is determined by both components of the phase in  $G_*$  and  $V$ , its frequencies—as defined here—are determined only by the former.

(ii) The analysis of the frequencies of unbounded motions made here applies as well to relative equilibria of noncompact groups.

**2.E The effect of the group on the prevalence of quasi-periodicity or drifting.** Ashwin and Melbourne in [2] make the interesting remark that, in a given group  $G$ , there may be a ‘preferred’ behaviour between quasi-periodicity and drifting, which is due to a prevalence of elements  $g \in G$  that generate either a compact or a noncompact subgroup (see also, for the case of  $SE(n)$ , [22]). In fact,  $G$  decomposes as the union of the two disjoint subsets

$$\begin{aligned} G_{\text{QP}} &:= \{g \in G : H(g) \text{ is compact}\} \\ G_{\text{D}} &:= \{g \in G : H(g) \text{ is not compact}\} \end{aligned}$$

and, if one of them is significantly ‘larger’ than the other, then the corresponding dynamical behaviour may be expected to be preferred. In [2], this fact is characterized at the Lie algebra level, but we prefer to work in  $G$ .

Specifically, [2] points out that the two subsets

$$\begin{aligned} \mathfrak{g}_{\text{QP}} &:= \{\eta \in \mathfrak{g} : K(\eta) \text{ is compact}\} \\ \mathfrak{g}_{\text{D}} &:= \{\eta \in \mathfrak{g} : K(\eta) \text{ is not compact}\} \end{aligned}$$

(where  $K(\eta)$  is defined as in (7)) of the Lie algebra  $\mathfrak{g}$  are semialgebraic sets (namely, closed sets defined by polynomial equations and inequalities). We recall that a semialgebraic subset  $A$  of a vector space  $E$  contains a dense subset which is a submanifold of  $E$ , and whose dimension (codimension) defines the dimension (codimension) of  $A$ .

It is elementary to translate these facts to  $G$  if—as we do assume—the exponential map  $\exp : \mathfrak{g} \rightarrow G$  is surjective. If  $g = \exp(\eta)$ , then as already noticed  $H(g)$  is compact if and only if  $K(\eta)$  is compact. Therefore,

$$G_{\text{QP}} = \exp(\mathfrak{g}_{\text{QP}}), \quad G_{\text{D}} = \exp(\mathfrak{g}_{\text{D}}).$$

If the group  $G$  is not a matrix group, then  $G_{\text{QP}}$  and  $G_{\text{D}}$  cannot be regarded as semialgebraic sets. However, since the exponential map is a local diffeomorphism, each of the two sets  $G_{\text{QP}}$  and  $G_{\text{D}}$  contains a maximal submanifold (the image of the maximal submanifold of  $\mathfrak{g}_{\text{QP}}$  and  $\mathfrak{g}_{\text{D}}$ ) which is dense in it, whose dimension equals the dimension of  $\mathfrak{g}_{\text{QP}}$  and  $\mathfrak{g}_{\text{D}}$ . We may thus define  $\dim G_{\text{QP}} := \dim \mathfrak{g}_{\text{QP}}$  and  $\dim G_{\text{D}} := \dim \mathfrak{g}_{\text{D}}$ . And it may happen that, in a given group, the dimension of either  $G_{\text{QP}}$  or  $G_{\text{D}}$  exceeds the other.

It is instructive, in this regard, to compare  $SE(n)$ , namely the semidirect product  $SO(n) \ltimes \mathbb{R}^n$ , to the direct product  $SO(n) \times \mathbb{R}^n$ . These two Lie groups have the same differentiable structure as manifolds, but different group structures, with products  $(R, r)(S, s) = (RS, r + Rs)$  in the former and  $(R, r)(S, s) = (RS, r + s)$  in the latter.

- In  $G = SE(n)$ ,  $\text{codim} G_{\text{QP}} = 0$  and  $\text{codim} G_{\text{D}} = 1$  if  $n$  is even, the opposite if  $n$  is odd ([2, 22]).
- In  $G = SO(n) \times \mathbb{R}^n$ , instead, the prevailing behaviour is always drifting. In fact,  $(R, r)^n = (R^n, nr)$  and  $H((R, r))$  is compact if and only if  $r = 0$ . Thus,  $G_{\text{D}} = SO(n) \times \{r \neq 0\}$  is an open submanifold of  $SO(n) \times \mathbb{R}^n$  while its complement  $SO(n) \times \{0\}$  is a submanifold of dimension  $n(n-1)/2$ . It follows that  $\text{codim} G_{\text{D}} = 0$  and  $\text{codim} G_{\text{QP}} = n$ .

At least at the Lie group or Lie algebraic level, therefore, it may happen that one of the two behaviours—quasiperiodicity or drifting—is generic and the other exceptional. In such a situation, unless peculiarities of the dynamics select phases that belong to the exceptional subset of the Lie group, the prevalent behaviour is *a priori* expected to take place.

### 3 Phases and frequencies in robotic locomotion

**3.A Control systems for robotic locomotion.** The class of *locomotion* control systems that we consider is formed by control systems of the form

$$\dot{s}(t) = u(t), \quad \dot{g}(t) = \sum_{i=1}^m X_i(s(t), g(t))u_i(t),$$

where: (1) The configuration space is the product  $M = S \times G \ni (s, g)$  of a connected  $n$ -dimensional Lie group  $G$  and of an  $m$ -dimensional manifold  $S$ , which is assumed to be parallelizable (so that  $TS \approx S \times \mathbb{R}^m$  and it is meaningful to consider the components  $u_i$  of its tangent vectors). (2) The  $u$ 's are the controls. (3) The vector fields  $X_1, \dots, X_m$  on  $G$  are assumed to be (for each fixed  $s$ ) left-invariant, so that  $X_i(s, g) = T_e L_g \cdot A_i(s)$  with smooth maps  $A_i : S \rightarrow \mathfrak{g}$ ,  $i = 1, \dots, m$ . Thus, a locomotion control system is given by

$$\dot{s} = u, \quad \dot{g} = \sum_{i=1}^m T_e L_g \cdot A_i(s)u_i \quad (s, g) \in S \times G. \quad (10)$$

The points of  $S$  are often interpretable as ‘shapes’ of the system, and the elements of  $G$  as its ‘configurations’ or ‘positions’. For instance, for a planar system formed by two articulated rigid rods immersed in a viscous fluid, such as the ‘scallop’ considered in [40], the configuration space  $G$

is  $SE(2)$  (position and orientation of one rod) while the shape space  $S$  is  $S^1$  (mutual orientation of the two rods).

In view of the first equation (10), the controls  $t \mapsto u(t) \in \mathbb{R}^m$  assign the *velocities* of the shape changes as a function of time. General theorems on non-smooth ordinary differential equations (see e.g. [1]) ensure that, given any measurable map  $u : \mathbb{R} \rightarrow \mathbb{R}^m$ , any  $t_0 \in \mathbb{R}$  and any  $(s_0, g_0) \in S \times G$ , there is a unique map  $(s, g) : \mathcal{J} \rightarrow S \times G$  which is defined on a maximal interval  $\mathcal{J}$  that contains  $t_0$ , is absolutely continuous,<sup>4</sup> satisfies  $(s(t_0), g(t_0)) = (s_0, g_0)$  and satisfies (10) at almost any  $t \in \mathcal{J}$ . Furthermore, this map depends in an absolutely continuous way on  $t_0$  and smoothly on  $(s_0, g_0)$ .

One may prefer to regard the curve  $\mathbb{R} \ni t \mapsto s(t) \in S$ , rather than its derivative, as the control—and we will do this way. Since any absolutely continuous map is almost everywhere differentiable with a measurable derivative, the previous results imply that, given any absolutely continuous curve  $\mathbb{R} \ni t \mapsto s(t) \in S$ , any  $t_0 \in \mathbb{R}$  and any  $g_0 \in G$ , there exists a unique map  $t \mapsto g(t) \in G$  which is defined in a maximal interval  $\mathcal{J} \ni t_0$ , satisfies  $g(t_0) = g_0$ , is absolutely continuous and satisfies

$$\dot{g}(t) = T_e L_{g(t)} \cdot \sum_{i=1}^m A_i(s(t)) \dot{s}_i(t) \quad (11)$$

at almost all  $t \in \mathcal{J}$ . Furthermore, this map (that we will call the solution of the control system (11) with initial datum  $g_0$  at time  $t_0$  relative to the given control  $t \mapsto s(t)$ ) depends in an absolutely continuous way on  $t_0$  and is smooth in  $g_0$ .

We will assume that all solutions of (11) exist for all times. Thus, for any absolutely continuous control  $\hat{s} : \mathbb{R} \rightarrow S$  there is an absolutely continuous nonautonomous flow map

$$\Phi^{\hat{s}} : \mathbb{R} \times \mathbb{R} \times G \rightarrow G, \quad (t_0, t, g_0) \mapsto \Phi_{t, t_0}^{\hat{s}}(g_0) \quad (12)$$

such that  $\Phi_{t, t_0}^{\hat{s}}(g_0)$  is the value at time  $t$  of the solution of (11) with initial datum  $g_0$  at time  $t_0$  relative to the control  $\hat{s}$ . By the left-invariance of (11),

$$\Phi_{t, 0}^{\hat{s}}(g_0) = g_0 \Phi_{t, 0}^{\hat{s}}(e) \quad \forall t \in \mathbb{R}, g_0 \in G.$$

Furthermore,  $\Phi_{t_2, t_1}^{\hat{s}} \circ \Phi_{t_1, t_0}^{\hat{s}} = \Phi_{t_2, t_0}^{\hat{s}}$  for all  $t_0, t_1, t_2 \in \mathbb{R}$ . It follows that  $\Phi_{t, t_0}^{\hat{s}} : G \rightarrow G$  is a diffeomorphism with inverse  $\Phi_{t_0, t}^{\hat{s}}$  for all  $t_0, t \in \mathbb{R}$ .

*Remark:* The configuration space  $M = S \times G$  can be interpreted as the total space of a trivial principal bundle with base  $S$ , fiber  $G$  and projection  $\pi : S \times G \rightarrow S$ ,  $\pi(s, g) = s$ . Correspondingly, the map

$$\mathcal{A} : TS \rightarrow \mathfrak{g}, \quad \mathcal{A}(s, \dot{s}) = \sum_{i=1}^m A_i(s) \dot{s}_i \quad (13)$$

can be regarded as a principal connection on this principal bundle. This interpretation has been emphasized, e.g., in [42, 37, 31]. We will not need this interpretation, but we will use this terminology.

**3.B Phases and dynamics for periodic controls.** We are interested in periodic controls. For any  $s_0 \in S$  and  $T > 0$ , let  $\mathcal{L}_{s_0}^T$  be the space of all absolutely continuous (parametrized) curves  $\ell : \mathbb{R} \rightarrow S$  which are periodic with minimal period  $T$  and satisfy  $\ell(0) = \ell(T) = s_0$ . We call these curves  $T$ -periodic *gaits* with basepoint  $s_0$ . Next, we define the space  $\mathcal{L}_{s_0}$  of gaits of any period with basepoint  $s_0$ , the space  $\mathcal{L}^T$  of gaits of period  $T$  with any basepoint, and the space  $\mathcal{L}$  of all gaits in  $S$ :

$$\mathcal{L}_{s_0} := \bigcup_{T>0} \mathcal{L}_{s_0}^T, \quad \mathcal{L}^T := \bigcup_{s_0 \in S} \mathcal{L}_{s_0}^T, \quad \mathcal{L} := \bigcup_{s_0 \in S} \mathcal{L}_{s_0} = \bigcup_{T>0} \mathcal{L}^T.$$

<sup>4</sup>We assume that a Riemannian metric has been chosen on  $S \times G$ , so as to give a meaning to the absolute continuity of curves in  $S \times G$ .

Note that we do not require the restriction to the interval  $[0, T)$  of a  $T$ -periodic gait to be injective. Therefore, the image of a gait may have self-intersection points (Figure 2.b), may contain closed subgaits ran more than once (Figure 2.c), and may even be a non-closed curve ran twice in opposite directions (Figure 2.d). (The reason for not requiring injectivity is for the concatenation of gaits to be a gait, see below).

To any gait  $\ell \in \mathcal{L}$  we associate its nonautonomous flow map  $\Phi^\ell$  as in (12). Clearly, if  $\ell \in \mathcal{L}^T$ , then  $\Phi_{t+T, t_0+T}^\ell = \Phi_{t, t_0}^\ell$  for all  $t_0, t$ .

**Definition 2.** *The phase map for the control problem (11) is the map  $\gamma : \mathcal{L} \rightarrow G$  which to any gait  $\ell \in \mathcal{L}^T$  of period  $T > 0$  associates the group element  $\gamma(\ell) := \Phi_{T, 0}^\ell(e)$ .*



Figure 2: Images of gaits

Equation (11) has the same form as the reconstruction equation (4) in a relative periodic orbit of an equivariant vector field on  $TS \times G$ , but with two differences. One is that, at variance with reduced periodic orbits, control gaits may have self-intersections; in such a case the phase can be defined through an obvious composition process. The other is that solutions of (11) need not be smooth. Thus, all conclusions of Section 2 and of the Appendix apply to equation (11), with the only difference that the conjugation to quasi-periodic motions is absolutely continuous rather than smooth. With this caveat, we have that, given a gait  $\ell \in \mathcal{L}$ :

- i. If the subgroup  $H(\gamma(\ell))$  is compact, then  $t \mapsto ((\ell(t), \ell'(t)), \Phi_{t, 0}^\ell(e))$  is a quasi-periodic curve with  $k + 1$  frequencies, for some  $0 \leq k \leq \text{rank}(G)$ . Its component  $t \mapsto \Phi_{t, 0}^\ell(e)$  is contained in a compact subset of  $G$ .
- ii. If the subgroup  $H(\gamma(\ell))$  is not compact, then  $t \mapsto ((\ell(t), \ell'(t)), \Phi_{t, 0}^\ell(e))$  is a drifting curve. Its component  $t \mapsto \Phi_{t, 0}^\ell(e)$  leaves any compact subset of  $G$  as  $t \rightarrow \pm\infty$ .

In case i., the frequencies  $\omega_0, \omega_1, \dots, \omega_k$  can be computed as explained in Sections 2.C. If  $G$  is the semidirect product of a compact group and of a vector space, as explained in Section 2.D frequencies can be attached to drifting motions as well.

From a trajectory generation perspective, one might be interested in determining which gaits have phases that belong to  $G_D$  or  $G_{QP}$ , namely, in determining the sets  $\gamma(\mathcal{L}) \cap G_D$ ,  $\gamma(\mathcal{L}^T) \cap G_D$  etc. A first information comes from the knowledge of  $G_D$  and  $G_{QP}$  themselves, particularly if one of the two is prevalent. On top of that, in any given system, the specificities of the connection  $\mathcal{A}$  that appears in equation (11) may play a role—in particular, the phase map might not be surjective, and only subsets of the two sets  $G_D$  and  $G_{QP}$  might be reached.

In conclusion we note that, in practice, there is a difference between the control problem and the dynamics in a relative periodic orbit. In a control problem the interest is on the motion  $t \mapsto \Phi_{t, 0}^\ell(e) \in G$ , which takes place in the group  $G$ , not on the motion  $t \mapsto ((\ell(t), \ell'(t)), \Phi_{t, 0}^\ell(e))$  which is the analogous of the motion in a relative periodic orbit. Therefore, what is actually observed in a control system is the analogous of the *projection* to  $G$  of the motion in the relative



periodic orbit  $\bar{R} \times G$ , and the projected motion may lose one frequency. We will illustrate this fact in the examples of Section 4.

### 3.C Behaviour of the phase under gaits' concatenation and time-reparametrization.

We point out now two properties of phases of locomotion systems.

1. *Gaits concatenation.* The space  $\mathcal{L}_{s_0}$  of all gaits based at a point  $s_0$  can be equipped with a product ("concatenation") defined as follows: if  $\ell_1 \in \mathcal{L}_{s_0}^{T_1}$  and  $\ell_2 \in \mathcal{L}_{s_0}^{T_2}$ , then  $\ell_1 \star \ell_2$  is the  $(T_1 + T_2)$ -periodic curve defined by

$$\ell_1 \star \ell_2(t) := \begin{cases} \ell_1(t) & \text{if } 0 \leq t \bmod(T_1 + T_2) \leq T_1 \\ \ell_2(t) & \text{if } T_1 \leq t \bmod(T_1 + T_2) \leq T_1 + T_2. \end{cases}$$

If, as we will always assume,  $\ell_1$  and  $\ell_2$  have different images, then  $\ell_1 \star \ell_2 \in \mathcal{L}_{s_0}^{T_1+T_2}$ . (If they have the same image, then  $T_1 + T_2$  is not the minimal period of  $\ell_1 \star \ell_2$ ). Obviously:

**Proposition 2.**  $\gamma(\ell_1 \star \ell_2) = \gamma(\ell_1)\gamma(\ell_2)$  for all  $\ell_1, \ell_2 \in \mathcal{L}_{s_0}$ .

This has the consequence that, if  $G_{QP}$  is not a subgroup of  $G$ , it may happen that  $\gamma(\ell_1 \star \ell_2) \in G_D$  even if  $\gamma(\ell_1), \gamma(\ell_2) \in G_{QP}$ . Thus, it may be possible to build gaits that produce drifting motions by concatenating gaits that, individually, produce quasiperiodic motions. The opposite may happen to the products of gaits whose phase is in  $G_D$  (which is never a subgroup, because  $e \notin G_D$ ).

For a generic group  $G$ , there are no explicit algorithms to design the individual gaits  $\ell_1$  and  $\ell_2$  so as to produce a desired phase  $\gamma(\ell_1 \star \ell_2)$ . However, this is elementary for  $G = SE(2)$  and  $SE(3)$ . If we regard  $SE(n)$  as  $SO(n) \times \mathbb{R}^n \ni (R, r)$  with product  $(R, r)(S, s) = (RS, r + Rs)$  and write  $\gamma = (\gamma_*, \gamma_V)$  with  $\gamma_* \in SO(n)$  and  $\gamma_V \in \mathbb{R}^n$  (see Section 2.B), then

$$\gamma(\ell_1 \star \ell_2)_* = \gamma(\ell_1)_* \gamma(\ell_2)_*, \quad \gamma(\ell_1 \star \ell_2)_V = \gamma(\ell_1)_V + \gamma(\ell_1)_* \gamma(\ell_2)_V.$$

When  $n = 2$ , if each  $\gamma(\ell_i)_*$  is a rotation of angle  $\theta_i$ , then  $\gamma(\ell_1 \star \ell_2)_*$  is a rotation of angle  $\theta_1 + \theta_2$ . When  $n = 3$ , the axis and angle of the rotation  $\gamma(\ell_1 \star \ell_2)_*$  can be read off those of  $\gamma(\ell_1)_*$  and  $\gamma(\ell_2)_*$  using e.g. quaternions.

2. *Gaits reparametrization.* Second, for locomotion systems, the linearity in  $\dot{s}$  of the connection (13) has the consequence that the phase of a control gait is independent of its time-parametrization. This follows from the following known fact, whose proof is immediate (see also [12], which however considers only time-reparametrizations of class  $C^1$ ).

**Lemma 2.** Consider an interval  $\mathcal{J} \subseteq \mathbb{R}$  and let  $g : \mathcal{J} \rightarrow G$  be the solution with initial datum  $g_0$  at time  $t_0$  of equation (10) with a certain absolutely continuous map  $s : \mathcal{J} \rightarrow S$ . Consider an interval  $\tilde{\mathcal{J}} \subseteq \mathbb{R}$  and a homeomorphism  $\tau : \tilde{\mathcal{J}} \rightarrow \mathcal{J}$  which is absolutely continuous together with its inverse. Then,  $\tilde{g} := g \circ \tau$  is the solution of equation (10) with the map  $s$  replaced by  $s \circ \tau$  and initial datum  $g_0$  at time  $\tau^{-1}(t_0)$ .

Given  $T, \tilde{T} > 0$  and  $\tilde{t}_0 \in \mathbb{R}$ , consider an absolutely continuous homeomorphism  $\tau_0 : [\tilde{t}_0, \tilde{t}_0 + \tilde{T}] \rightarrow [0, T]$  and lift it to a map  $\tau : \mathbb{R} \rightarrow \mathbb{R}$  by defining

$$\tau(t + p\tilde{T}) := \tau_0(t) + pT \quad \forall t \in [\tilde{t}_0, \tilde{t}_0 + \tilde{T}], p \in \mathbb{Z},$$

which is an absolutely continuous homeomorphism as well. Clearly, if  $\ell \in \mathcal{L}_{s_0}^T$ , then  $\tilde{\ell} := \ell \circ \tau \in \mathcal{L}_{s_0}^{\tilde{T}}$  with base point  $\tilde{s}_0 = \ell(\tau(0))$ .

**Proposition 3.** For any absolutely continuous homeomorphism  $\tau : \mathbb{R} \rightarrow \mathbb{R}$  of the type just introduced there exists  $g_\tau \in G$  such that, for all  $\ell \in \mathcal{L}^T$ ,  $\gamma(\ell \circ \tau) = g_\tau \gamma(\ell) g_\tau^{-1}$  if  $\tau$  is orientation preserving and  $\gamma(\ell \circ \tau) = g_\tau \gamma(\ell)^{-1} g_\tau^{-1}$  if  $\tau$  is orientation reversing.

*Proof.* Let  $\tilde{\ell} = \ell \circ \tau$ . By Lemma 2,  $\Phi_{\tilde{t}, \tilde{t}_0}^{\tilde{\ell}} = \Phi_{\tau(\tilde{t}), \tau(\tilde{t}_0)}^{\ell}$  for all  $\tilde{t}, \tilde{t}_0 \in \mathbb{R}$ . Therefore, using the periodicity of  $\tilde{\ell}$  and the link between the two nonautonomous flows,

$$\gamma(\tilde{\ell}) = \Phi_{\tilde{T}, 0}^{\tilde{\ell}}(e) = \Phi_{\tilde{T}, \tilde{T} + \tilde{t}_0}^{\tilde{\ell}} \circ \Phi_{\tilde{T} + \tilde{t}_0, \tilde{t}_0}^{\tilde{\ell}} \circ \Phi_{\tilde{t}_0, 0}^{\tilde{\ell}}(e) = \Phi_{0, \tilde{t}_0}^{\tilde{\ell}} \circ \Phi_{\tau(\tilde{T} + \tilde{t}_0), \tau(\tilde{t}_0)}^{\ell} \circ \Phi_{\tilde{t}_0, 0}^{\tilde{\ell}}(e).$$

Hence, by equivariance,  $\gamma(\tilde{\ell}) = \Phi_{\tilde{t}_0, 0}^{\tilde{\ell}}(e) \Phi_{\tau(\tilde{T} + \tilde{t}_0), \tau(\tilde{t}_0)}^{\ell}(e) \Phi_{0, \tilde{t}_0}^{\tilde{\ell}}(e) = g_{\tau} \Phi_{\tau(\tilde{T} + \tilde{t}_0), \tau(\tilde{t}_0)}^{\ell}(e) g_{\tau}^{-1}$  with  $g_{\tau} = \Phi_{\tilde{t}_0, 0}^{\tilde{\ell}}(e)$ . The proof is now concluded observing that  $\Phi_{\tau(\tilde{T} + \tilde{t}_0), \tau(\tilde{t}_0)}^{\ell}(e) = \Phi_{T, 0}^{\ell}(e)$  if  $\tau$  preserves the orientation and  $\Phi_{\tau(\tilde{T} + \tilde{t}_0), \tau(\tilde{t}_0)}^{\ell}(e) = \Phi_{0, T}^{\ell}(e) = \Phi_{T, 0}^{\ell}(e)^{-1}$  if it reverses the orientation.  $\square$

This implies that, unless a gait contains closed subgaits (as in Figure 2.c), its phase is a property of its (oriented) image alone.

**3.D Example: The scallop theorem.** An extreme case is that of a gait of period  $T$  whose image is an arc of a non-closed curve which is ran twice, first in a direction, then in the other, as in Figure 2.d.

It is well known (Purcell’s “scallop theorem” [40]) that the phase of any such gait is trivial, namely, it is the group identity. Within our setting, the proof of this fact is immediate. We may reparametrize time so that the gait satisfies  $\ell(t) = \ell(T - t)$  for all  $t \in [0, T]$ . Thus, if  $\tau(t) = T - t$ ,  $\ell \circ \tau = \ell$  and hence, by Lemma 2,  $\Phi_{T, T/2}^{\ell} = \Phi_{T, T/2}^{\ell \circ \tau} = \Phi_{0, T/2}^{\ell} = (\Phi_{T/2, 0}^{\ell})^{-1}$  so that  $\gamma(\ell) = \Phi_{T, T/2}^{\ell} \circ \Phi_{T/2, 0}^{\ell}(e) = e$ ; the conclusion now follows from Proposition 3.

Hence, if the shape space  $S$  is one-dimensional and diffeomorphic to  $\mathbb{R}$ , then the phase map  $\gamma$  maps  $S$  onto the group identity. Non-trivial phases are instead possible if the shape space is diffeomorphic to a circle  $S^1$ . The consequences of these facts on the self-propulsion of micro swimmers have been extensively discussed by Purcell himself [40].

*Remark:* There is an extensive literature on the scallop theorem, which has been reconsidered from a variety of perspectives. The statement and proof above seem to us to be exactly in the spirit of Purcell’s ideas (who did not formalize his theorem): the gaits which are ran twice formalize the “reciprocal motions” of [40] and the time reparametrization formalizes Purcell’s statement that “Time, in fact, makes no difference—only configuration”.

## 4 Examples from locomotion systems

We provide now some examples, chosen from locomotion systems, to illustrate the theory and the considerations of the previous sections. We focus mostly on the simple but typical case of  $G = SE(2)$ , but we very shortly consider also the cases of  $SE(2) \times S^1$  and  $SE(3)$ . All these groups have the semidirect product structure of Section 3.C, and we may speak of frequencies of drifting motions in the sense specified there.

Reconstruction for  $SE(2)$ -invariant systems appear in various works, see particularly [22, 21], and the results in Section 4.A are known, except for the introduction of the frequencies of unbounded motions.

**4.A Phases and frequencies in  $SE(2)$ .** We regard  $SE(2)$  as the semidirect product  $S^1 \ltimes \mathbb{R}^2 \ni (\langle \alpha \rangle, r)$  with product

$$(\langle \alpha \rangle, r) \cdot (\langle \beta \rangle, s) = (\langle \alpha + \beta \rangle, r + R_{\alpha} s).$$

Here  $S^1 = \mathbb{R}/(2\pi\mathbb{Z})$  and, for any real  $x$ ,  $\langle x \rangle = x \pmod{2\pi}$  and  $R_x = \begin{pmatrix} \cos x & -\sin x \\ \sin x & \cos x \end{pmatrix}$ . The group identity is  $e = (\langle 0 \rangle, 0) \in S^1 \times \mathbb{R}^2$  and the inverse of an element  $(\langle \alpha \rangle, r)$  is  $(\langle -\alpha \rangle, -R_{-\alpha} r)$ .



Correspondingly, the Lie algebra  $\mathfrak{se}(2)$  is identified with  $\mathbb{R} \oplus \mathbb{R}^2$  and the  $S^1$ -component of the exponential map  $\exp : \mathbb{R} \oplus \mathbb{R}^2 \rightarrow S^1 \times \mathbb{R}^2$  is that of  $S^1$ . Thus,

$$\exp(\dot{\theta}, \dot{r}) = (\langle \dot{\theta} \rangle, \star) \quad \forall (\dot{\theta}, \dot{r}) \in \mathbb{R} \oplus \mathbb{R}^2; \quad (14)$$

the expression of the  $\mathbb{R}^2$ -component of  $\exp$ , here denoted  $\star$ , is not important for us because, as pointed out before, the frequencies in the relative periodic orbits are independent of it. In this identification, a basis of  $\mathbb{R} = \mathfrak{s}^1$  which, after multiplication by  $2\pi$ , generates  $\ker(\exp_{S^1})$  is formed by the number 1.

As already mentioned, the generic behaviour for  $SE(2)$  is quasi-periodicity [2, 22]. In detail,  $(\langle \alpha \rangle, r)^n = (\langle n\alpha \rangle, \sum_{k=0}^n R_{k\alpha} r)$  for all  $n > 0$ , and a similar formula for  $n < 0$ . Therefore, if  $\langle \alpha \rangle = 0$  and  $r \neq 0$  then the  $\mathbb{R}^2$ -component of  $(\langle \alpha \rangle, r)^n$  moves along a straight line, and  $H(\langle \alpha \rangle, r)$  is not compact. In all other cases such a component moves on a circle (if  $\langle \alpha \rangle \neq 0, r \neq 0$ ) or is a point (if  $\langle \alpha \rangle = 0, r = 0$ ), and  $H(\langle \alpha \rangle, r)$  is compact. Hence,

$$SE(2)_D = \{\langle 0 \rangle\} \times (\mathbb{R}^2 \setminus \{0\}), \quad SE(2)_{QP} = \{(\langle 0 \rangle, 0)\} \cup ((S^1 \setminus \{\langle 0 \rangle\}) \times \mathbb{R}^2).$$

Note that  $SE(2)_D$  is a two-dimensional submanifold of  $SE(2)$  while  $SE(2)_{QP}$  is the union of a point and of a three-dimensional submanifold. Thus,  $SE(2)_D$  has codimension one and  $SE(2)_{QP}$  has codimension zero.

Consider now a locomotion system with group  $SE(2) \ni (\langle \theta \rangle, r = (x, y))$  and an  $m$ -dimensional shape space  $S$ ,  $m \geq 1$ . If  $\eta = (\dot{\theta}, \dot{r}) \in \mathbb{R} \oplus \mathbb{R}^2 = \mathfrak{se}(2)$  then  $T_{(\langle 0 \rangle, 0)} L_{(\theta, v)} \cdot \eta = (\dot{\theta}, R_{\theta} \dot{r})$ . Therefore, if for every  $i = 1, \dots, m$  we write

$$A_i(s) =: (A_i^*(s), A_i^V(s)) \in \mathbb{R} \times \mathbb{R}^2$$

(where the “\*” and the “V” have the meaning of Section 2.C, with now  $G_* = S^1$  and  $V = \mathbb{R}^2$ ), then equation (11) takes the form

$$\dot{\theta}(t) = \sum_{i=1}^m A_i^*(s(t)) \dot{s}_i(t), \quad \dot{r}(t) = \sum_{i=1}^m R_{\theta(t)} A_i^V(s(t)) \dot{s}_i(t). \quad (15)$$

These equations have the structure (9) of semidirect products, with that for  $\theta$  being the ‘first reduced’ equation in  $S^1$ . Correspondingly, they allow to determine the phase of a gait with two consecutive integrations. Specifically, if for any  $\ell \in \mathcal{L}^T$  we define

$$\theta^\ell(t) := \sum_{i=1}^m \int_0^t A_i^*(\ell(\tau)) \ell'_i(\tau) d\tau$$

then  $\gamma(\ell) = (\gamma_*^\ell, \gamma_V^\ell)$  with

$$\gamma_*^\ell = \langle \theta^\ell(T) \rangle, \quad \gamma_V^\ell = \sum_{i=1}^m \int_0^T R_{\theta^\ell(t)} A_i^V(\ell(t)) \ell'_i(t) dt.$$

Hence (see also [22, 21]):

**Proposition 4.**  $\gamma(\ell) \in SE(2)_D$  if and only if

$$\theta^\ell(T) = 0 \pmod{2\pi} \quad \text{and} \quad \gamma_V^\ell \neq 0.$$

We now consider the frequencies of motions in the relative periodic orbit. As discussed in Section 2.D, they are the frequencies produced by reconstructing the gait with the action of  $S^1$ ,

namely, with the first equation (15). Since  $S^1$  has rank one, motions may have at most two frequencies, one of which is the frequency  $\omega_0 = \frac{2\pi}{T}$  of the control gait. The other frequency, if present, is determined by the  $S^1$ -component  $\gamma_*^\ell = \langle \theta^\ell(T) \rangle$  of the phase. According to (14) we have  $\gamma_*^\ell = \exp(T\eta_*^\ell)$  with, for instance,  $\eta_*^\ell = \frac{\theta^\ell(T)}{T}$ , or else  $\eta_*^\ell = \frac{\theta^\ell(T)+2\pi q}{T} = \frac{\theta^\ell(T)}{T} + q\omega_0$  with any  $q \in \mathbb{Z}$ . The first choice leads to the second frequency

$$\omega_1 = \frac{\theta^\ell(T)}{T}.$$

Thus:

1. In a drifting motion  $\langle \theta^\ell(T) \rangle = 0$  and we may choose  $\eta_*^\ell = 0$ . Motions have the single frequency  $\omega_0$ . This means that the projection of the motion in  $\bar{R} \times S^1$  is periodic with the period  $T$  of the gait. Note that if  $\theta^\ell(T) = 2\pi q$  for some  $q \neq 0$ , then  $t \mapsto \theta(t)$  increments itself of an integer multiple of  $2\pi$  in each gait's period.
2. Quasi-periodic motions are met in two cases:
  - 2.1.  $\langle \theta^\ell(T) \rangle = 0$ ,  $\gamma_V^\ell = 0$ . This is the trivial case where the phase is the identity. Choosing  $\eta_*^\ell = 0$  does not produce a second frequency. Here too, the projection of motions in  $\bar{R} \times S^1$  is  $T$ -periodic.
  - 2.2. If  $\langle \theta^\ell(T) \rangle \neq 0$  (and either  $\gamma_V^\ell \neq 0$  or  $\gamma_V^\ell = 0$ ) then motions are quasi-periodic with the two frequencies  $\omega_0$  and  $\omega_1$ . If  $\omega_1/\omega_0 = \frac{\theta^\ell(T)}{2\pi}$  is irrational, then the projection of the motion in  $\bar{R} \times S^1$  fills it densely; otherwise, it is periodic.

As already pointed out, even if the frequency  $\omega_1$  arises in the reconstruction of the  $S^1$ -component of the motion, it may affect also the evolution of the  $\mathbb{R}^2$ -component. Moreover, the motion  $t \mapsto (\theta(t), r(t))$  in the group might lose one frequency.

We now illustrate this situation on two control systems with shape spaces  $S$  of dimensions two and three, respectively. (If  $S$  is one-dimensional, and simply connected, then by the scallop theorem  $SE(2)_D$  is always empty).

*Remark:* In cases 1. and 2.1, choosing  $\eta_*^\ell = 2\pi q$  with  $q \in \mathbb{Z}$  gives  $\omega_1 = q\omega_0$ ; hence, the number of independent frequencies remain 1, consistently with the fact that the projection of motions in  $\bar{R} \times S^1$  is periodic.

**4.B A car robot.** We consider here a simplified model of a car that moves on a horizontal plane. This is a slightly modified version of a model studied in [39] and reconsidered in other works, e.g. in the textbook [10] (for the differences see section 4.C). The car is formed by three articulated rigid bodies: the rear and front wheels attached to the car's frame—say, a rod of length  $\lambda$  that connects the center  $C_1$  of the front wheel to the center  $C_2$  of the rear wheel. The wheels are modelled as rigid disks of equal radius  $a\lambda$  with some  $a < 1/2$ , which are free to rotate about their horizontal axes and are constrained to touch the plane and stand vertically. The front wheel is also free to rotate about its vertical axis, which allows to steer the car. See figure 3 (where for convenience the car is depicted more like a bike).

The configuration manifold of this (holonomically constrained, so far) mechanical system is  $M = S^1 \times \mathbb{R}^2 \times S^1 \times S^1 \times S^1 \ni (\theta, (x, y), \psi_1, \psi_2, \phi)$ , where  $(x, y)$  are the coordinates of the projection in the plane of a chosen point of the frame, say the center  $C_2$  of the rear wheel, the angle  $\theta$  fixes the orientation of the frame in the plane,  $\psi_1$  and  $\psi_2$  are rotation angles of the front and rear wheels about their horizontal axes, respectively, and  $\phi$  is the steering angle of the front wheel. (To simplify the notation, we now specify that angles are to be taken mod  $2\pi$  only where this might cause ambiguities).

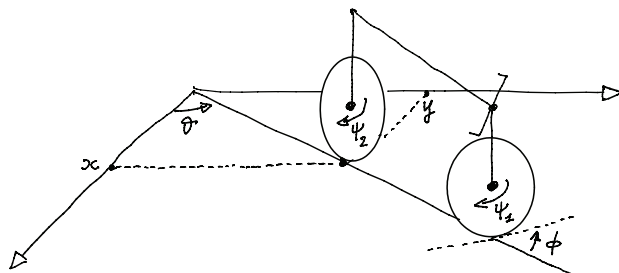

Figure 3: The car robot

The system is also subjected to the non-holonomic constraint that the two wheels cannot slide on the plane, so that the velocities of their contact points with the plane are zero. These conditions are

$$\begin{aligned} \dot{x} - a\lambda\dot{\psi}_2 \cos \theta &= 0, & \dot{y} - a\lambda\dot{\psi}_2 \sin \theta &= 0, \\ \dot{x} - \lambda\dot{\theta} \sin \theta - a\lambda\dot{\psi}_1 \cos(\theta + \phi) &= 0, & \dot{y} + \lambda\dot{\theta} \cos \theta - a\lambda\dot{\psi}_1 \sin(\theta + \phi) &= 0 \end{aligned}$$

and define a distribution on  $M$  of constant rank 2. All the fibers of this distribution, but those on points with  $\phi = \pm \frac{\pi}{2}$ ,<sup>5</sup> can be parametrized with  $(\psi_2, \phi) \in \mathbb{R}^2$  as

$$\dot{\theta} = a\dot{\psi}_2 \tan \phi, \quad \dot{x} = a\lambda\dot{\psi}_2 \cos \theta, \quad \dot{y} = a\lambda\dot{\psi}_2 \sin \theta, \quad \dot{\psi}_1 = \frac{\dot{\psi}_2}{\cos \phi}. \quad (16)$$

Assume now that the controller can assign the rotation angle  $\psi_2$  of the rear wheel and the steering angle  $\phi$  of the front wheel; in order to keep the two controls independent, we assume that the steering angle can only assume values  $|\phi| < \frac{\pi}{2}$  (see the previous footnote). Equations (16) can be viewed as a robotic locomotion system with group  $G = SE(2) \times S^1$ , the direct product of  $SE(2) \ni (\theta, x, y)$  and of  $S^1 \ni \psi_1$ , and shape space  $S = S^1 \times (-\frac{\pi}{2}, \frac{\pi}{2}) \ni (\psi_2, \phi)$ . The product in  $SE(2) \times S^1$  is  $(\theta, r, \psi_1) \cdot (\theta', r', \psi_1') = ((\theta + \theta'), r + R_\theta r', \psi_1 + \psi_1')$ . If we identify the Lie algebra with  $\mathbb{R} \times \mathbb{R}^2 \times \mathbb{R}$ , then the connection of the locomotion system (16) has components

$$A_{\psi_2}(\psi_2, \phi) = (a \tan \phi, (a\lambda, 0), 1/\cos \phi), \quad A_\phi(\psi_2, \phi) = 0. \quad (17)$$

In the notation of (15),  $A_{\psi_2}^* = (a \tan \phi, 1/\cos \phi)$  and  $A_{\psi_2}^V = (a\lambda, 0)$ . The vanishing of the  $\phi$ -component of the connection reflects the fact that equations (16) are invariant under translations of  $\dot{\phi}$ ; nevertheless, the connection depends on the angle  $\phi$ .

**4.C The car robot with  $G = SE(2)$ .** Ref. [39] considers a slightly different model, in which the drive wheel is the front one. Moreover, ref. [39] ignores the rotational configuration of the rear wheel (as if, e.g., the rear wheel was replaced by a point touching the plane) and focuses on the motion of the frame of the car, which is parametrized by  $(\theta, x, y) \in SE(2)$ . We can do something similar here, ignoring the rotational configuration of the *front* wheel, namely the angle  $\psi_1$  (as if the front wheel were replaced by a knife's blade), because the connection (17) is independent of that angle. In this way we obtain a locomotion system (11) given by the first three equations (16), namely

$$\dot{\theta} = a\dot{\psi}_2 \tan \phi, \quad \dot{x} = a\lambda\dot{\psi}_2 \cos \theta, \quad \dot{y} = a\lambda\dot{\psi}_2 \sin \theta, \quad (18)$$

<sup>5</sup> If  $\phi = \pm \frac{\pi}{2}$ , then the rear wheel must have zero rotation speed  $\dot{\psi}_2$ . There is also a global parametrization of all the fibers of the distribution with  $(\dot{\psi}_1, \dot{\phi}) \in \mathbb{R}^2$ , which reflects the fact that the rotation speed of the front wheel is free when  $\phi = \pm \frac{\pi}{2}$ . This parametrization could be advantageously used if the drive wheel were the front one, as in [39] (who however neglects the rotation of the rear wheel).

on the group  $G = SE(2) \ni (\theta, x, y)$ , with shape space  $S = S^1 \times (-\frac{\pi}{2}, \frac{\pi}{2}) \ni (\psi_2, \phi)$  and connection  $A_{\psi_2}(\psi_2, \phi) = (a \tan \phi, (1, 0))$ ,  $A_\phi = 0$ .

From Proposition 4 it follows that a gait  $\ell = (\psi_2^\ell, \phi^\ell) \in \mathcal{L}^T$  leads to a drifting phase in  $SE(2)$  if and only if

$$\langle \theta^\ell(T) \rangle = 0 \quad \text{and} \quad \int_0^T \begin{pmatrix} \dot{\psi}_2^\ell(t) \cos(\theta^\ell(t)) \\ \dot{\psi}_2^\ell(t) \sin(\theta^\ell(t)) \end{pmatrix} dt \neq \begin{pmatrix} 0 \\ 0 \end{pmatrix} \quad (19)$$

with

$$\theta^\ell(t) = a \int_0^t \dot{\psi}_2^\ell(\tau) \tan(\phi^\ell(\tau)) d\tau.$$

Thus, a necessary condition for a gait  $\ell$  to generate drifting motions is that it takes the spatial orientation  $t \mapsto \langle \theta(t) \rangle$  of the car's frame back to its initial value. If any such gait is not too special—so that the second condition (19) is satisfied—then it does actually generate a drifting phase.

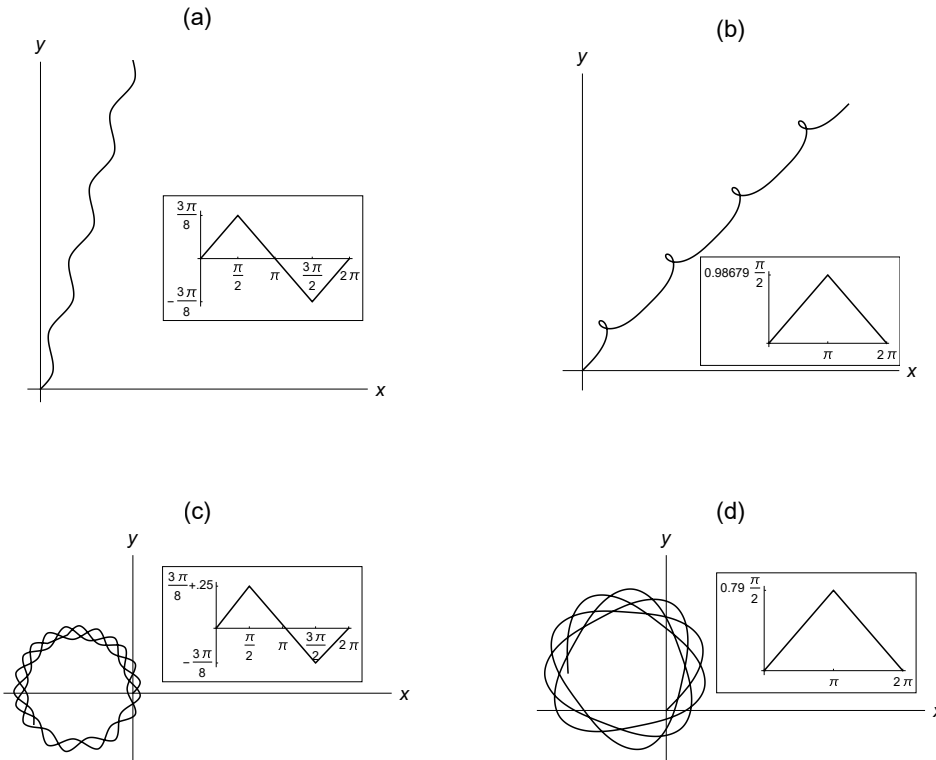

Figure 4: Four trajectories of a point of the car's frame in the  $(x, y)$ -plane. The gaits have  $\dot{\psi}_2^\ell = 1$  and  $\phi^\ell$  as shown in the insets. The coordinates in the insets' plots are time (horizontal) and  $\phi^\ell$  (vertical). In all cases  $\lambda = 2.5$ ,  $a = 0.4$  and the initial configuration of the car is  $(\theta_0, x_0, y_0) = (\pi/4, 0, 0)$ . The value of  $\theta^\ell(T)$  is 0 in (a),  $2\pi$  in (b), approximately  $0.262\pi$  in (c) and approximately  $0.727\pi$  in (d).

We now discuss a few examples. Note that it follows from Lemma 2 that, if the controls are such that the drive wheel does not reverse or stop its spinning, it is always possible—with a reparametrization of time—to reduce to a constant  $\dot{\psi}_2$ , and even to  $\dot{\psi}_2 = 1$ . We thus consider only  $2\pi$ -periodic gaits with

$$\dot{\psi}_2^\ell(t) = \langle t \rangle$$

and specify the gait giving  $\phi^\ell$  alone. Even though the drifting behaviour is not generic, it is easy to design gaits that produce it. For instance:

0. A trivial example of a gait that satisfies both conditions (19) is given by  $\phi^\ell(t) = 0$  for all  $t$ : by (19), the car runs straight forward.
1. Any absolutely continuous, odd,  $2\pi$ -periodic function  $\phi^\ell : \mathbb{R} \rightarrow (-\frac{\pi}{2}, \frac{\pi}{2})$  gives a gait with  $\theta^\ell(T) = 0$ .
2. Suitably designed periodic functions  $\phi^\ell : \mathbb{R} \rightarrow (-\frac{\pi}{2}, \frac{\pi}{2})$  are needed to produce drifting phases with  $\theta^\ell(T) = 2\pi q$ ,  $q \in \mathbb{Z} \setminus \{0\}$ .

Generic gaits—including generic small perturbations of the previous ones—give however quasi-periodic behaviours. Figures 4.a-4.d show the trajectories of a point of the car's frame in the plane (only the  $(x, y)$  coordinates are shown) as a result of gaits of the types above. The first two refer to drifting motions and the last two to quasi-periodic motions.

We do not show in the Figure the trajectory relative to a gait of type 0., which is simply a straight line. However, we note that in case 0. the absence of any quasi-periodic or periodic behaviour is an example of the fact that the projection in the group can lose one of the frequencies. In this specific case, this happens because the  $\mathfrak{s}^1$ -component of the Lie algebra element  $A_{\psi_2}$  is zero if  $\phi^\ell = 0$ .

In each example in the Figure the function  $t \mapsto \phi^\ell(t)$  is a triangle wave, shown in the inset. The non-constancy of  $\phi^\ell$  makes the  $\mathfrak{s}^1$ -component of the Lie algebra element  $A_{\psi_2}$  non-zero, and the gait gives its frequency to the motion in the group. As we know from Section 4.A, this is the only frequency for drifting motions, while pure quasi-periodic motions may get an extra frequency. This is clearly visible in the Figures:

- In Figure 4.a,  $\phi^\ell$  is an odd function, as in case 1., and  $\theta^\ell(T) = 0$ . The motion is drifting, and the wobbling of the trajectory of the car's frame reflects the periodicity of the gait.
- In Figure 4.b  $\phi^\ell$  has been (carefully) chosen so that  $\theta^\ell(T) = 2\pi$ . Not shown is the orientation of the car, which makes a full turn in each gait's period.
- Figures 4.c and 4.d refer to 'generic' gaits, for which  $\langle \theta^\ell(T) \rangle \neq 0$ . The reconstruction introduces a second frequency to the motion, which is thus quasi-periodic with two frequencies. The appearance of a second, longer period is evident in the pictures.

Since  $SE(2)_{QP}$  is not a subgroup of  $SE(2)$ , drifting phases may also be produced by suitably concatenating gaits that individually produce the generic quasi-periodic behaviour. For instance, the gait in Figure 4.a is the concatenation of two  $\pi$ -periodic gaits which, individually, produce quasi-periodic motions. Other examples are easily built.

**4.D The car robot with  $G = SE(2) \times S^1$ .** In the previous example the rank of the group  $G = SE(2)$  is 1. Hence, the reconstruction can contribute at most one frequency to the motions (and in fact, this happens only for the quasi-periodic motions). If, as in Section 4.B, the car robot is regarded as a control system with group  $G = SE(2) \times S^1$ , which has rank two, then the reconstruction can contribute two frequencies to the motions. In particular, drifting motions may have two frequencies, and quasi-periodic motions may have three frequencies. However, the extra frequency corresponds to the rotation of the front wheel and no new frequency is observed in the trajectory of the car on the plane.

**4.E A planar amoeba-like swimmer.** An example with group  $SE(2)$  and a three-dimensional shape space is provided by the amoeba-like planar swimmers [38, 32, 44]. In a particular model, the swimmer is modeled as a set in  $\mathbb{R}^2$  whose boundary is a smooth curve that depends on three shape parameters  $s = (s_1, s_2, s_3) \in \mathbb{R}^3$  and is given, in polar coordinates  $(\rho, \sigma)$ , by the equation

$$\rho = \rho_0(1 + s_1 \cos(2\sigma) + s_2 \cos(3\sigma) + s_3 \sin(3\sigma))$$

with a constant  $\rho_0 > 0$ . The configuration manifold of the control problem is thus  $SE(2) \times \mathbb{R}^3 = S^1 \times \mathbb{R}^2 \times \mathbb{R}^3 \ni (\theta, (x, y), s)$ , with  $(\theta, x, y)$  that fix position and orientation of a (suitably defined) swimmer's reference frame. Under hypotheses discussed in [38, 44], which include the fact that the swimmer starts with zero linear momentum, the control system is

$$\dot{\theta} = -\mu s_3 \dot{s}_2 + \nu s_2 \dot{s}_3, \quad \begin{pmatrix} \dot{x} \\ \dot{y} \end{pmatrix} = R_\theta \begin{pmatrix} -\mu s_2 \dot{s}_1 + s_1 \dot{s}_2 \\ -\mu s_3 \dot{s}_1 + s_1 \dot{s}_3 \end{pmatrix}$$

where  $\mu$  and  $\nu$  are two positive parameters that depend on the mass of the swimmer and on the density of the fluid. These equations are of the form (15).

It thus follows from Proposition 4 that a  $T$ -periodic gait  $t \mapsto \ell(t) = (s_1^\ell(t), s_2^\ell(t), s_3^\ell(t))$  produces drift if and only if

$$\langle \theta^\ell(T) \rangle = 0 \quad \text{and} \quad \int_0^T R_{\theta^\ell(t)} \begin{pmatrix} \mu s_2^\ell(t) \dot{s}_1^\ell(t) - s_1^\ell(t) \dot{s}_2^\ell(t) \\ \mu s_3^\ell(t) \dot{s}_1^\ell(t) - s_1^\ell(t) \dot{s}_3^\ell(t) \end{pmatrix} dt \neq \begin{pmatrix} 0 \\ 0 \end{pmatrix} \quad (20)$$

with, now,

$$\theta^\ell(t) = \int_0^t (\nu s_2^\ell(\tau) \dot{s}_3^\ell(\tau) - \mu s_3^\ell(\tau) \dot{s}_2^\ell(\tau)) d\tau. \quad (21)$$

Since the group is  $SE(2)$ , the predominant behaviour is quasi-periodicity. Let us thus focus on gaits that produce the exceptional drifting behaviour.

Trivial examples are given by the two classes of gaits with either  $s_2^\ell = 0$  and any  $s_1^\ell, s_3^\ell$  such that  $\int_0^T (\mu s_3^\ell(t) \dot{s}_1^\ell(t) - s_1^\ell(t) \dot{s}_3^\ell(t)) dt \neq 0$  (which produce translation in the direction  $\begin{pmatrix} -\sin \theta^\ell \\ \cos \theta^\ell \end{pmatrix}$ ) or  $s_3^\ell = 0$  and any  $s_1^\ell, s_2^\ell$  such that  $\int_0^T (\mu s_2^\ell(t) \dot{s}_1^\ell(t) + s_1^\ell(t) \dot{s}_2^\ell(t)) dt \neq 0$  (which produce a translation along the direction  $\begin{pmatrix} \cos \theta^\ell \\ \sin \theta^\ell \end{pmatrix}$ ).

More generally, any  $s_2^\ell \in \mathcal{L}^T$  and  $s_3^\ell = (s_2^\ell)^{\mu/\nu}$  give  $\theta^\ell(t) = 0$  for all  $t$  and therefore, if they satisfy (20), produce a drifting motion. The same happens if  $s_2^\ell = c s_3^\ell$  with a real constant  $c \neq 0$ . But there are also other possibilities. For example, if the  $T$ -periodic functions  $s_2^\ell$  and  $s_3^\ell$  are both odd or both even, then the integrand in (21) averages to zero, so again  $\theta^\ell(T) = 0$  and drifting motions can be produced.

The discussion of the frequencies of these motions is analogous to that of the car robot.

**4.F 3D swimmers.** There are interesting examples also with  $G = SE(3)$ , such as the three dimensional swimmers immersed either in an ideal or in a viscous fluid presented in [13, 34]. As already noticed, for this group the generic case is drifting [2, 22].

Indeed, let us write the elements of  $SE(3) = SO(3) \ltimes \mathbb{R}^3$  as  $(\exp \hat{\omega}, r)$  with  $\omega, r \in \mathbb{R}^3$  (here, as usual,  $\hat{\omega}$  is the antisymmetric matrix that represents the cross product  $\omega \times \cdot$  in  $\mathbb{R}^3$ ). Note that  $(\exp(\hat{\omega}), r)^n = (\exp(n\hat{\omega}), \sum_{k=0}^{n-1} \exp(k\hat{\omega})r)$  if  $n > 0$ , and a similar expression for  $n < 0$ . If  $\omega \neq 0$  the component of  $\sum_{k=0}^{n-1} \exp(k\hat{\omega})r$  parallel to  $\omega$  grows linearly with  $n$ , while its component in the plane orthogonal to  $\omega$  rotates. Remembering the case of  $SE(2)$ , one concludes that

$$SE(3)_{QP} = \{(\exp(\hat{\omega}), r) : \omega \cdot r = 0 \text{ except } (\omega = 0, r \neq 0)\} \\ SE(3)_D = \{(\exp(\hat{\omega}), r) : \omega \cdot r \neq 0 \text{ or } (\omega = 0, r \neq 0)\}.$$

Thus  $SE(3)_{QP}$  has codimension one and  $SE(3)_D$  has codimension zero.

We do not treat these examples here, but we limit ourselves to note that, since  $SE(3)$  has rank one, motions may have at most two frequencies as in the case of the planar swimmer.

## 5 Conclusions

In this paper we highlighted the relevance of the qualitative properties of the dynamics in relative periodic orbits of equivariant dynamical systems for control theory. Specifically, this was done for trajectory generation via periodic controls in a class of driftless control systems on Lie groups called robotic locomotion systems.

From the perspective of dynamical systems with symmetry, we identified the frequencies of drifting motions in relative periodic orbits for groups which are the semi-direct product of a compact group and of a vector space, among which  $SE(n)$  is one of the most representative examples. An extension of this result to more general non-compact Lie groups is an interesting problem that will be the subject of future work.

A point to stress is that in our study we did not take into account any optimization problem. Instead, our focus is on trajectory generation, which is more closely related to controllability, i.e. the possibility of finding control functions that steer the system between two given configurations. However, optimization is central to control theory. In a recent work [27] it is shown that, for a quadratic optimization problem for an equivariant locomotion system with two controls, the optimal controls are periodic. Thus, a possible future research direction is to apply the ideas highlighted in this paper to the study of the relative periodic orbits obtained from such periodic optimal controls.

Finally, we mention that our qualitative approach has been recently applied [41] to trajectory generation for a nonholonomic system known as the hydrodynamic Chaplygin sleigh [21], whose governing equations, even if  $SE(2)$ -invariant, are not of the form (1). Specifically, the  $SE(2)$ -reduced space is the product of the shape space  $S$  and of the momentum space  $\mathfrak{g}^*$ . Not every periodic control of the shape produces a periodic reduced orbit in  $S \times \mathfrak{g}^*$ . However, in this case, for certain classes of shape controls the reduced equations become linear non homogeneous in the momenta, and via Floquet theory it is possible to prove that there exist periodic controls of the shape which produce periodic reduced orbits. The reconstruction procedure can thus be applied to them. This same approach could be easily extended to the class of nonholonomic systems forming the so called *pure transport case* [6], whose reduced equations are also linear non homogeneous in the momenta. More challenging would be to study more general classes of shape-controlled nonholonomic systems, whose reduced equations are nonlinear in the momenta and Floquet theory does not apply.

## 6 Appendix: Quasi-periodic motions

For completeness, we describe here in some detail the known results from [25, 2, 15] about the quasi-periodic dynamics in a relative periodic orbit.

**Proposition 5.** *Let  $X$  be a  $G$ -invariant vector field on  $M = \bar{M} \times G$ . Assume that the solution  $t \mapsto \bar{m}(t)$  of the reduced equation  $\dot{\bar{m}} = \bar{X}(\bar{m})$  with initial datum  $\bar{m}_0$  is periodic with minimal period  $T$ . Let*

$$P = \bar{R} \times G,$$

with  $\bar{R} = \bar{m}(\mathbb{R})$ , be the corresponding relative periodic orbit and  $\gamma$  be its phase. Assume that  $H(\gamma)$  is compact.

Then there exist an integer  $k$ ,  $0 \leq k \leq \text{rank}(G)$ , a smooth embedding

$$\mathcal{P} : S^1 \times \mathbb{T}^k \hookrightarrow \bar{R} \times G = P$$

and, if  $k > 0$ , a vector  $\omega \in \mathbb{R}^k$  which are such that<sup>6</sup>

$$\Phi_t^X(\bar{m}_0, g) = \Psi_g \circ \mathcal{P}\left(\left\langle \frac{2\pi}{T}t, \langle \omega t \rangle \right\rangle\right) \quad \forall g \in G, t \in \mathbb{R}. \quad (22)$$

---

<sup>6</sup>Recall that  $G$  acts on  $P = \bar{R} \times G$  by left translations on the factor  $G$ , namely  $\Psi_g(\bar{m}, h) = (\bar{m}, gh)$ .



Moreover, the sets

$$\mathcal{T}_g := \Psi_g \circ \mathcal{P}(S^1 \times \mathbb{T}^k), \quad g \in G,$$

are diffeomorphic to  $\mathbb{T}^{k+1}$ ,  $\Phi^X$ -invariant and are the fibers of a  $G$ -principal fibration of  $P$ .

*Proof.* For simplicity, assume that there exists  $\eta \in \mathfrak{g}$  such that  $\gamma = \exp(T\eta)$  and define  $K(\eta)$  as in (7). We write  $K$  for  $K(\eta)$ . As noticed in Section 4.C, if  $H(\gamma)$  is compact then  $K$  is a torus of  $G$  of some dimension  $k$ .

Choose a basis  $\{\xi_1, \dots, \xi_k\}$  of  $\text{lie}(K)$  formed by vectors which after multiplication by  $2\pi$  generate  $\ker(\exp_K)$ . Then, the map

$$J_1 : S^1 \times \mathbb{T}^k \times \mathbb{R} \rightarrow S^1 \times K, \quad (\langle \tau \rangle, \langle \alpha \rangle) \mapsto (\langle \tau \rangle, \exp_K(\sum_{i=1}^k \alpha_i \xi_i)).$$

is a diffeomorphism. Consider the map

$$\hat{J}_2 : S^1 \times G \rightarrow \bar{R} \times G, \quad (\langle \tau \rangle, g) \mapsto \left( \bar{m}\left(\frac{\tau}{\omega_0}\right), g \exp_G\left(-\frac{\tau}{\omega_0}\eta\right) \mathcal{G}\left(\frac{\tau}{\omega_0}\right) \right).$$

A computation shows that it is well defined (namely, independent of the choice of  $\tau$  in the equivalence class), injective and immersive (see e.g. the proof of Proposition 2 in [17] for a similar computation in the case of compact  $G$ ). Moreover it is surjective: a point  $(\bar{m}^\circ, g^\circ) \in \bar{R} \times G$  is the image of  $(\langle \tau^\circ \rangle, g^\circ) \in S^1 \times G$  with  $\langle \tau^\circ \rangle$  such that  $\bar{m}(\tau^\circ/\omega_0) = \bar{m}^\circ$  and  $g^\circ = g^\circ \exp_G(-\frac{\tau^\circ}{\omega_0}\eta)\mathcal{G}(\frac{\tau^\circ}{\omega_0})^{-1}$ .

Thus,  $\hat{J}_2$  is a diffeomorphism.

Being a closed subgroup of  $S^1 \times G$ ,  $S^1 \times K$  is an embedded submanifold of it. Therefore, the restriction  $J_2 := \hat{J}_2|_{S^1 \times K}$  of the diffeomorphism  $\hat{J}_2$  to  $S^1 \times K$  is an embedding, and so is  $\mathcal{P} := J_2 \circ J_1 : S^1 \times K \rightarrow \bar{R} \times G$ . Explicitly,

$$\mathcal{P}(\langle \tau \rangle, \langle \alpha \rangle) = \left( \bar{m}\left(\frac{\tau}{\omega_0}\right), \exp_K\left(\sum_{i=1}^k (\alpha_i - \frac{\tau}{\omega_0}\omega_i)\xi_i\right) \mathcal{G}\left(\frac{\tau}{\omega_0}\right) \right)$$

where  $\omega_1, \dots, \omega_k \in \mathbb{R}$  are the components of  $\eta$  in the basis  $\xi_1, \dots, \xi_k$  of  $\text{lie}(K)$ , see (8). Hence

$$\mathcal{P}(\langle \omega_0 \tau \rangle, \langle \omega t \rangle) = (\bar{m}(t), \mathcal{G}(t)) = \Phi_t^X(\bar{m}_0, e_G).$$

Equality (22) follows from here because, by equivariance, for any  $g_0 \in G$  the integral curve with initial datum  $(\bar{m}_0, g_0)$  is  $t \mapsto (\bar{m}(t), g_0 \mathcal{G}(t)) = \Psi_{g_0}(\Phi_t^X(\bar{m}_0, e_G))$ .

Since  $S^1 \times K$  is a closed subgroup of  $S^1 \times G$ , its action by right translations on  $S^1 \times G$ , which is given by

$$\Psi_{(\langle \sigma \rangle, h)}(\langle \tau \rangle, g) = (\langle \tau + \sigma \rangle, gh),$$

is free and proper and its orbits  $S^1 \times gK$ ,  $g \in G$ , are the fibers of a principal bundle  $p : S^1 \times G \rightarrow (S^1 \times G)/(S^1 \times K)$  (see e.g. [16], section 1.11), and are diffeomorphic to  $\mathbb{T}^{k+1}$ . The base of this bundle can be identified with  $G \backslash K$ . Thus,  $p \circ \hat{J}_2^{-1} : P \rightarrow G \backslash K$  is a locally trivial fibration with fibers  $\hat{J}_2(S^1 \times gK) = \Psi_{(\langle 0 \rangle, g)} \circ J_2(S^1 \times K) = \Psi_{(\langle 0 \rangle, g)} \circ \mathcal{P}(S^1 \times \mathbb{T}^k) = \mathcal{T}_g$ .  $\square$

## References

- [1] A.A. Agrachev and Y.L. Sachkov, *Control Theory from the Geometric Viewpoint*. Encyclopaedia of Mathematical Sciences **87**. (Springer-Verlag, Berlin, 2004)
- [2] P. Ashwin and I. Melbourne, *Noncompact drift for relative equilibria and relative periodic orbits*. Nonlinearity **10** (1997), 595-616.
- [3] Alberto Bressan, *Impulsive Control of Lagrangian Systems and locomotion in fluids*. Discrete Contin. Dyn. Syst. **20** (2008), 1-35.
- [4] Aldo Bressan, *Hyper-impulsive motions and controllizable coordinates for Lagrangean systems*, Atti Accad. Naz. Lincei, Memorie, Serie VIII, XIX (1990), 197-246.



- [5] B. Bittner, R.L. Hatton and S. Revzen, *Geometrically optimal gaits: a data-driven approach*. Nonlinear Dynamics **94** (2018), 1933-1948.
- [6] A.M. Bloch, *Nonholonomic Mechanics and Controls*. Interdisciplinary Applied Mathematics **24**, Systems and Control. (Springer-Verlag, New York, 2003).
- [7] A.V. Borisov, A.A. Kilin and I.S. Mamaev, *How to Control the Chaplygin Ball Using Rotors II*. Regul. Chaotic Dyn. **18** (2013) 144-158.
- [8] T. Bröcker and T. tom Dieck, *Representations of Compact Lie Groups*. Graduate Texts in Mathematics 98. (Springer, New York, 1985).
- [9] R.W. Brockett, *Systems theory on group manifolds and coset spaces*. SIAM J. Control **10** (1972), 265-284.
- [10] F. Bullo and A.D. Lewis, *Geometric control of mechanical systems. Modeling, analysis, and design for simple mechanical control systems*. Texts in Applied Mathematics **49** (Springer-Verlag, New York, 2005).
- [11] A. Cabrera, *Base-controlled mechanical systems and geometric phases*. Journal of Geometry and Physics **58** (2008), 334-367.
- [12] T. Chambrion and A. Munnier, *Generalized scallop theorem for linear swimmers*. Preprint INRIA-00508646 (2010).
- [13] T. Chambrion and A. Munnier, *Generic controllability of 3D swimmers in a perfect fluid*. SIAM J. Control Optim. **50** (2012), 2814-2835.
- [14] G. Cicconofri and A. DeSimone, *Modelling biological and bio-inspired swimming at microscopic scales: Recent results and perspectives*. Computers and Fluids **179** (2019) 799-805.
- [15] R. Cushman, J.J. Duistermaat and J. Śnyaticki, *Geometry of Nonholonomically Constrained Systems* (Advanced Series in Nonlinear Dynamics vol 26) (World Scientific, Singapore, 2010).
- [16] J.J. Duistermaat and J.A.C. Kolk, *Lie Groups*. (Springer, Berlin, 2000).
- [17] F. Fassò and A. Giacobbe, *Geometry of invariant tori of certain integrable systems with symmetry and an application to a nonholonomic system*. SIGMA Symmetry Integrability Geom. Methods Appl. **3** (2007), Paper 051, 12 pp.
- [18] F. Fassò, L.C. García-Naranjo and A. Giacobbe, *Quasi-periodicity in relative quasi-periodic tori*. Nonlinearity **28** (2015), 4281-4301.
- [19] F. Fassò, L.C. García-Naranjo and J. Montaldi, *Integrability and dynamics of the n-dimensional symmetric Veselova top*. Journal of Nonlinear Science **29** (2019), 1205-1246.
- [20] V. Fedonyuk and P. Tallapragada, *Sinusoidal control and limit cycle analysis of the dissipative Chaplygin sleigh*. Nonlinear Dynamics **93** (2018), 835-846.
- [21] Y.N. Fedorov, L.C. García-Naranjo and J. Vankerschaver, *The motion of the 2d hydrodynamical Chaplygin sleigh in the presence of circulation*. Discrete Continuous Dynamical Systems **33** (2013), 4017-4040.
- [22] B. Fiedler, B. Sandstede, A. Scheel and C. Wulff, *Bifurcation from relative equilibria of noncompact group actions: skew products, meanders, and drifts*. Doc. Math. J. DMV **1** (1996), 479-505.
- [23] B. Fiedler and D. Turaev, *Normal Forms, Resonances, and Meandering Tip Motions near Relative Equilibria of Euclidean Group Actions*. Arch. Rational Mech. Anal. **145** (1998) 129-159.
- [24] M.J. Field, *Equivariant dynamical systems*. Trans. Am. Math. Soc. **259** (1980), 185-205.
- [25] M.J. Field, *Local structure for equivariant dynamics*. In *Singularity Theory and its Applications. Part II*, ed. M. Roberts and I. Stewart, 142-166. Lecture Notes in Mathematics 1463 (Springer, Berlin, 1991).
- [26] M.J. Field, *Dynamics and Symmetry*. (Imperial College Press, London, 2007).
- [27] L. Giraldi and F. Jean, *Periodical body's deformations are optimal strategies for locomotion*. (2019) hal-02266220.

- [28] M. Golubitsky and I. Stewart, *The Symmetry Perspective. From Equilibrium to Chaos in Phase Space and Physical Space*. (Birkhäuser, Basel, 2002).
- [29] J. Hermans, *A symmetric sphere rolling on a surface*. Nonlinearity **8** (1995), 493-515.
- [30] V. Jurdjevic and H. Sussmann, *Control systems on Lie groups*. J. Differential Equations **12** (1972), 313-329.
- [31] S.D. Kelly and R.M. Murray, *Geometric phases and robotic locomotion*. Journal of Robotic Systems **12** (1995), 417-431.
- [32] V.V. Kozlov and S.M. Ramodanov, *On the motion of a variable body through an ideal fluid*. J. Appl. Math. Mech. **65** (2001), 579-587.
- [33] M. Krupa, *Bifurcations of relative equilibria*. SIAM J. Math. Anal. **21** (1990), 1453-1486.
- [34] J. Lohéac and A. Munnier, *Controllability of 3D low Reynolds number swimmers*. ESAIM Control Optim. Calc. Var. **20** (2014), 236-268.
- [35] C.M. Marle, *Géométrie des systèmes mécaniques à liaisons actives*, in “Symplectic Geometry and Mathematical Physics”, 260-287, P. Donato, C. Duval, J. Elhadad and G. M. Tuynman Eds. (Birkhäuser, Boston, 1991).
- [36] J.E. Marsden and T.S. Ratiu, *Introduction to Mechanics and Symmetry* (Springer, New York, 1999).
- [37] J.E. Marsden, R. Montgomery and T. Ratiu, *Reduction, symmetry and phases in mechanics*. Memoirs of the American Mathematical Society **88** (1990), number 436.
- [38] R. Mason and J. Burdick, *Propulsion and control of deformable bodies in a Ideal fluid*. Proceedings of the 1999 IEEE International Conference on Robotics & Automation, Detroit, Michigan, 773-780 (IEEE, 1999).
- [39] R.M. Murray and S.S. Sastry, *Nonholonomic Motion Planning: Steering Using Sinusoids*. IEEE Transactions on Automatic Control **38** (1993), 700-716.
- [40] E. M. Purcell, *Life at low Reynolds number*. American Journal of Physics, **45** (1977), 3–11.
- [41] N. Sansonetto and M.Zoppello *On the Trajectory Generation of the Hydrodynamic Chaplygin Sleigh*. IEEE Control System Letters DOI: 10.1109/LCSYS.2020.2996763
- [42] A. Shapere and F. Wilczek, *Geometry of self-propulsion at low Reynolds number*. J. Fluid Mech. **198** (1989), 557-585.
- [43] G.I. Taylor, *Analysis of the swimming of microscopic organisms*. Proc. R. Soc. Ser. A **209** (1951), 447-461.
- [44] M. Zoppello and F. Cardin, *Swim-like motion of bodies immersed in an ideal fluid*. ESAIM Control, Optimisation and Calculus of Variations **25** (2019), Art. 16, 38 pp.