

Experimental and numerical investigation of a porous receiver equipped with Raschig Rings for CSP applications

Original

Experimental and numerical investigation of a porous receiver equipped with Raschig Rings for CSP applications / Savoldi, L., Allio, A., Bonvento, A., Cantone, M., Fernandez Reche, J.. - In: SOLAR ENERGY. - ISSN 0038-092X. - ELETTRONICO. - 212:(2020), pp. 309-325. [10.1016/j.solener.2020.11.006]

Availability:

This version is available at: 11583/2859327 since: 2020-12-31T10:17:33Z

Publisher:

Elsevier Ltd

Published

DOI:10.1016/j.solener.2020.11.006

Terms of use:

This article is made available under terms and conditions as specified in the corresponding bibliographic description in the repository

Publisher copyright

Elsevier postprint/Author's Accepted Manuscript

© 2020. This manuscript version is made available under the CC-BY-NC-ND 4.0 license
<http://creativecommons.org/licenses/by-nc-nd/4.0/>. The final authenticated version is available online at:
<http://dx.doi.org/10.1016/j.solener.2020.11.006>

(Article begins on next page)

Experimental and numerical investigation of a porous receiver equipped with Raschig Rings for CSP applications

Laura Savoldi ^{1*}, Andrea Allio ¹, Antonio Bonvento ¹, Marco Cantone ¹, Jesus Fernandez Reche ²

¹ Dipartimento Energia "Galileo Ferraris", Politecnico di Torino, Torino (Italy);

² CIEMAT, Plataforma Solar de Almería, Tabernas-Almería (Spain)

* Corresponding author: laura.savoldi@polito.it; Tel.: +39 011 090 4559

Abstract: In the context of central solar tower systems, tubular receivers are among the most appealing absorber solutions: the absorbed solar radiation is transferred from the tube external surface to the heat transfer fluid (HTF) flowing within the absorber. In the case of air as HTF, very high temperatures of the coolant can be obtained in principle, thus increasing the efficiency of the downstream thermodynamic cycle. To explore the possible applicability of a porous medium made of Raschig Rings (RRs), already successfully adopted in the heat removal from the resonant cavity of a technological device, the gyrotron, where the heat flux can go up to 20-25 MW/m² and removed by subcooled water, a mock-up of a planar receiver equipped with RRs has been tested in a solar furnace, using air as coolant. The test results are presented here and analyzed¹. Furthermore, a numerical model of the mock-up, where the RRs are modeled in detail by the Discrete Element Method, is presented and its capability to reproduce the measured data demonstrated. The model shows, for the tested configuration, an enhancement of the heat transfer of a factor of ~ 5 with respect to a plain channel with the same envelope, and a Performance Evaluation Criteria of 2-2.5 when the device is compared to the same receiver configuration, but without RRs.

Keywords: CSP, Tubular receiver, CFD, Raschig Rings, Porous matrix, DEM

1. Introduction

In the context of concentrated solar power (CSP), tubular receivers for central solar tower systems can largely benefit from the use of porous matrices to enhance the heat transfer to the coolant. This paper focuses on the analysis of a porous medium never investigated so far for solar applications, i.e. the Raschig Rings, originally invented and developed for packed-bed reactors (Sella, 2008) and adopted in the removal of high heat fluxes in niche applications in the Nuclear Fusion field, namely the gyrotron resonant cavity.

CSP technologies use different mirror configurations to concentrate the sunlight energy onto a receiver and convert it into heat. The sun's rays are used to heat a medium, usually a fluid or a gas, that is then used in a heat engine process (steam or gas turbine) to drive an electrical generator and produce electricity or used as industrial process heat. CSP uses only the beam component of solar radiation (direct normal irradiance), and so its maximum benefit tends to be restricted to a limited geographical range (European Commission, 2019). Among the CSP systems, Solar Central Tower, with their single receiver placed on top of a tower surrounded by many heliostats and very high concentration ratios, can reach higher temperatures and greater thermodynamic cycle efficiency than other systems. This technology can produce utility-scale electricity, offering dispatchable power on demand by integrating thermal energy storage.

¹ Based on experiments carried out at the Plataforma Solar de Almería

43 In the context of solar towers, tubular receivers are probably the most appealing absorber
44 solutions (Conroy et al., 2019). At the commercial level, tubular receivers adopt liquid heat transfer
45 fluid, like water and molten salts; however, they can easily work also with pressurized gases, as
46 demonstrated for example in the SOLHYCO project (European Commission, 2011). The use of a
47 gaseous working fluid (typically pressurized air) could improve effectively the tubular receiver
48 performance since the gas has no upper temperature limit by itself, whereas the limit is set by the
49 thermo-mechanics of the pipes. In addition, when air is used as a working fluid, a gas turbine could
50 be directly driven by the solar field, allowing the implementation of a solar-driven combined cycle.
51 The advantages of air, however, are counterbalanced by the lower heat transfer coefficient (HTC)
52 with respect to liquids, which leads to higher temperatures of the tube wall and consequently higher
53 thermal stresses, which limit the applicable solar incident heat flux on the absorber surface. At the
54 same time, the wetted surface to transfer a given thermal power needs to be increased to compensate
55 for the low HTC, if the same temperature of liquid coolant is targeted at the outlet of the receiver.

56 The enhancement of the convective heat transfer between the tube wall and the coolant could
57 help reducing the peak temperature. That target can be achieved then by increasing the HTC or by
58 increasing the heat transfer surface, or both.

59 The first option was already explored in several studies, both experimentally and numerically,
60 investigating different possible alternatives. In the above mentioned SOLHYCO project (European
61 Commission, 2011), developed in 2006-2010 at the Plataforma Solar de Almeria, a profiled multilayer
62 tube receiver was demonstrated to enhance the heat transfer from the irradiated tube wall to the gas
63 and to reduce the temperature difference over the circumference of the tube. Tubes with an enhanced
64 heat transfer obtained through internal periodic ribs were experimentally investigated in (Yang et al.,
65 2010), using molten salt as cooling fluid, under a uniform heat flux to the pipe obtained using an
66 electric heater, demonstrating that the heat transfer of the tube equipped with helical ribs was three
67 times higher than that of the corresponding smooth pipe. In (Uhlig et al., 2015), corrugated tubes
68 equipped with helical ribs were analyzed numerically, without any experimental validation,
69 demonstrating that helical ribs reduce both the maximum and the average tube wall temperature. In
70 (Cantone et al., 2020), 3D-printed Inconel® tubes equipped with helical ribs or annular rings were
71 manufactured and tested within the SFERA II project at the Plataforma Solar de Almeria as solar
72 tubular receivers. The experimental and numerical (CFD) investigation of the one-side heated tubes
73 led to the conclusion that turbulence promoters allow reducing the thermal gradients between the
74 irradiated and the non-irradiated (back) side of the tube.

75 A way of enhancing the convective heat transfer from the wall to the fluid, alternative to any
76 attempt to increase directly the HTC, is to insert a porous medium under the irradiated surface.
77 Porous media are widely applied in industry to enhance the heat transfer rate from catalyst carriers
78 in chemistry, thermal exchange in electrical cooling, thermal insulation in buildings and astronautics,
79 low emission combustion technologies and receivers for concentrating solar power. The adoption of
80 porous media typically increases the useful heat transfer surface: a reduction of both convective and
81 radiative heat losses is expected, as well as the thermal stresses of the tube.

82 In the CSP field, porous media could be adopted either into the pipes of tubular receivers or as
83 receivers themselves. In the first case, it is easy to compare the performance to that of a “plain”
84 tubular receiver: the maximum applicable solar incident heat flux on the absorber surface could be
85 increased or the absorber area could be reduced for the same incident solar power, typically at the
86 cost of increased pressure drop across the tube. If the porous medium itself is adopted as a receiver,
87 we face a “volumetric receiver”, which is a thermal system where the concentrated radiation is
88 absorbed directly on the surface of a (porous) material, that transfers heat to a working fluid (typically
89 air). Different materials and shapes (ceramic structure of silicon carbide honeycomb (Hoffschimdt et
90 al., 1999), (Hoffschimdt et al., 2003), foams made out of aluminum oxide, coated with black paint to
91 increase the solar absorption (Skocypec et al., 1989) were designed and tested, reaching outlet
92 temperatures up to 700°C - 800°C (Hoffschimdt et al., 2003). Several numerical investigations were
93 also carried out on the volumetric receivers, focusing both on flow/pressure drop, see for instance
94 (Becker et al., 2006) and (Wu et al., 2010) and heat transfer, as in (Zhu et Xuan, 2018)). In (Cagnoli et

95 al., 2019), a coupled CFD and optical analysis allowed identifying the best configuration (e.g., pore
96 size) to maximize the receiver efficiency.

97 Considering the convective heat transfer enhancement obtained by porous media inserted *into*
98 tubular receivers, tests and analyses have been performed by different authors considering tubes
99 totally or partially filled by a porous matrix. Kumar (Kumar et al, 2009) presented a numerical
100 analysis of porous disc receiver for solar parabolic trough collectors, concluding from simulations
101 that the insertion of a porous medium in tubular solar receiver enhances the system performance
102 significantly (~64.3% in terms of Nusselt number Nu) with respect to the same tubular receiver in the
103 smooth configuration. Lim (Lim et al, 2014) performed a design optimization of a solar tubular
104 receiver filled with a metal foam, considering length, porosity and thermal conductivity of the metal
105 matrix as design factors. The authors of (Mwesigye et al., 2014) numerically investigated the thermal
106 and thermodynamic performance of a tubular receiver with perforated plate inserts for a parabolic
107 trough solar collector, with fixed porosity equal to 0.65. It was shown that the receiver temperature
108 gradients reduced significantly with the use of inserts; correlations for Nu and the friction factor f
109 were also derived from the numerical database. In (Zheng et al., 2017), the authors investigated a
110 tubular receiver, cooled with molten salts, partially filled with a metal foam matrix under a non-
111 uniform heat flux distribution. The optimized design resulted from a trade-off between improved
112 heat transfer and increased pressure drop, showing that the enhanced receiver tube (ERT) with
113 down-filling porous inserts (i.e., the porous medium fills only half of the cross-section, where the heat
114 flux is hitting the pipe) and in-filling porous inserts (i.e., the porous medium fills only an inner circle
115 of the pipe) has good thermal performance when the ratio of thermal conductivity of porous medium
116 to working fluid is less than 1000. In (Alkam et Al-Nimr, 1997) the authors numerically investigated
117 the problem of transient forced convection flow in a concentric annulus partially filled with porous
118 substrates located either on the inner or the outer cylinder. An increase of up to 12 times in Nu was
119 reported in comparison with the clear annuli case and the superiority in thermal performance of the
120 case when the porous substrate was emplaced to the inner cylinder was outlined. Based on those
121 results, in (Alkam et Al-Nimr, 1999) further investigations were carried out on the thermal
122 performance of a conventional concentric-tube heat exchanger by emplacing porous substrates on
123 both sides of the inner cylinder. Their numerical results showed that porous substrates of optimum
124 thickness leads to the maximum improvement in the heat exchanger performance with a moderate
125 increase in the pumping power. More recently, Mohamad (Mohamad, 2003) numerically investigated
126 the heat transfer augmentation for flow in a pipe or a channel partially or fully filled with porous
127 material emplaced at the core of the channel. It was shown that partially filling the channel with
128 porous substrates can reduce the thermal entrance length by 50% and increase the rate of heat transfer
129 from the walls.

130 In this study, the adoption of Raschig Rings (RR) (Sella, 2008) is investigated for the first time,
131 both experimentally and numerically, in applications within tubular receivers in the CSP field. A
132 receiver mock-up equipped with RRs, formerly used to assess thermal-hydraulic performance in a
133 forced flow of water for heat flux conditions in the range 10-30 MW/m² (Rozier, 2015), has been tested
134 at the Plataforma Solar de Almeria (PSA) in 2019, under different heat load and flow rate conditions
135 using pressurized air as a cooling fluid, in the framework of the SFERA III European Project.

136 Thermal experimental tests (as opposed to hydraulic tests, see (Allio et al., 2020)) on devices
137 equipped with RRs are not extensively documented in the literature, neither in the applications
138 related to the packed-bed reactors nor in those related to gyrotrons and their resonator cavity cooling.
139 Some numerical works have been performed in the past on RRs but related to other fields. Moghaddam
140 and coauthors (Moghaddam et al., 2020) studied the *hydrodynamics* of random packings
141 of RRs using the Rigid Body Dynamics (RBD) method and CFD simulations, demonstrating that the
142 ring orientation largely influences the velocity distribution, and greater azimuthal and axial
143 inhomogeneities occur with respect to spherical and cylindrical packings. In (Allio et al., 2020), an
144 alternative model, based on the generation of a random distribution of RR using the Discrete Element
145 Method (DEM) technique has been developed and validated against experimental results against
146 pure hydraulic experimental data. As far as the thermal aspects are concerned, Dong and coauthors
147 (Dong et al., 2017) improved innovative experimental techniques for high-quality temperature

148 measurement to validate DEM-CFD simulations of heat transfer in a fixed-bed reactor for both
149 spherical and RRs packings in moderate flow conditions and high-temperature ranges. There, the
150 model of *pure heat conduction* in the solid, subject to *uniform* heat flux, was proven to be correct. Marek
151 (Marek, 2017) carried out a numerical study of *laminar* gas flow in a real geometry of a random packed
152 bed of RRs, showing a good agreement with empirical correlations where pressure drop is expressed
153 as a function of the gas velocity. No modeling of turbulent flow or conjugate heat transfer is found in
154 the published literature. We address here for the first time the modeling and validation against
155 experimental data of the conjugate heat transfer problem in a turbulent fluid flow within a RR matrix.

156 After describing the sample, the test setup and presenting the hydraulic and thermal-hydraulic
157 test results obtained during the test campaign at PSA, we develop a suitable computational fluid
158 dynamic (CFD) model for the receiver mock-up, where the RR geometrical random distribution is
159 based on the DEM already used in (Allio et al., 2020). Even if the DEM strategy has been widely used
160 in solar projects, particularly for solar particle receivers, where solid particles are used as the heat
161 transfer medium, see (Zanino et al, 2016) and (Ho et al., 2017), this is the first time, to the best of our
162 knowledge, that the DEM is applied to generate the model of a porous media inside a receiver,
163 following what has already been done for the modeling of packed-beds and gyrotron resonators. The
164 validation of the model against the experimental data collected during the experimental campaign at
165 the PSA provides, within the error-bar, added value with respect to both (Allio et al., 2020), capturing
166 the conjugate heat transfer to the fluid, and (Marek, 2017), modeling the turbulent flow of the coolant.
167 The validated numerical model allows then to assess and quantify the increase of the thermal
168 performance with respect to a plain receiver not equipped with the RR porous matrix.

169 2. Mock-up and test facility

170 The Raschig Rings, used as a porous medium in the mockup under consideration in this work,
171 are hollow cylinders, approximately equal in length and diameter, used in large numbers often as a
172 packed bed within columns for distillations or other chemical engineering processes (Sella, 2008).
173 They are usually made of ceramic or metallic material and provide a large surface area within the
174 given volume. In the current work, the RRs are made of copper, coated with a gold alloy and brazed
175 together. The brazing process might modify some RRs thermal properties such as their thermal
176 conductivity, so that the effective conductivity of the porous matrix is unknown. The sketch of the
177 geometry of the single RR adopted here is shown in **Figure 1**. Even if the RR cavity cooling system is
178 patented by Thales, the precise dimension of the rings cannot be disclosed.

179
180

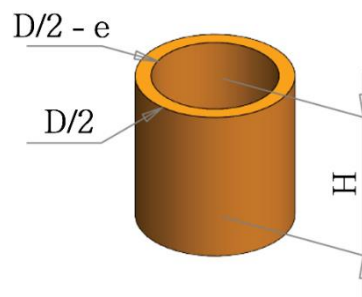

181

182 **Figure 1** - Schematic view of a single RR: the external diameter D and height H are in the order of few mm,
183 while the thickness e is such to allow making a foil cylinder.

184

185 In 2015, a planar mock-up of the gyrotron resonator has been manufactured by Thales Electronic
186 Devices SAS and tested at the Areva Premises under the surface heat load in the range 10 MW/m^2 -
187 30 MW/m^2 , obtained with an electron gun, using subcooled water as cooling fluid. The mock-up is
188 made of two different materials, copper and Glidcop, a family of copper-based metal matrix
189 composite (MMC) alloys mixed primarily with small amounts of aluminum oxide ceramic particles.

190 **Figure 2** shows a schematic representation of the Raschig Rings mock-up and the detail of the

191 instrumentation that was used to assess the temperature increase (thermocouple insertions below the
192 target area). The mock-up was designed and manufactured to have heat flux focused on the target
193 surface. A collection of pictures, taken in the workshop before the installation of the sample in the
194 solar furnace, are reported in **Figure 3**.
195

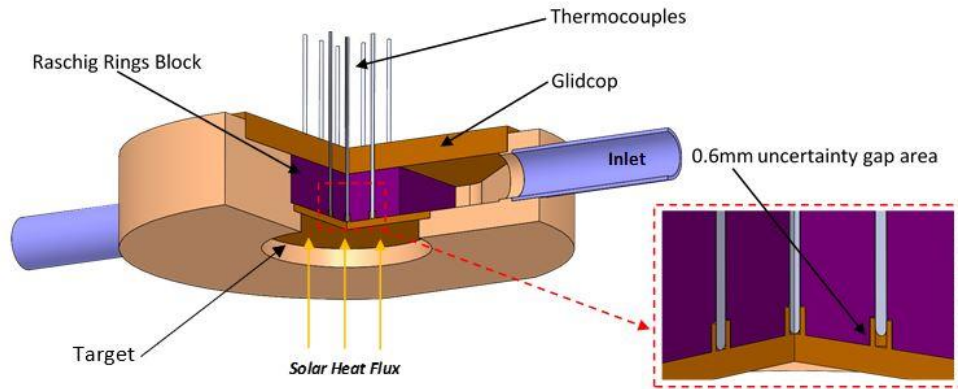

196
197 **Figure 2** - Schematic view of the RRs planar mock-up: the light-brown volume is made of copper, while the
198 brown one is made of Glidcop. The purple volume represents the portion of the volume filled with Raschig
199 Rings. On the right, a detail of the thermocouples shows the 0.6 mm uncertainty insertion gap space.
200

201 The RRs mock-up is equipped with 11 thermocouples (TCs) (**Figure 4**) of the K-type, Class
202 Tolerance I ($\pm 1.5^{\circ}\text{C}$ in range -40 to 375°C and $0.004 \times |T|$, where T is the measured temperature in
203 Celsius ($^{\circ}\text{C}$), in the range 375 - 1000°C). Specifically, it has one TC positioned at the inlet, before the
204 RRs section, one TC located at the outlet into the mixing chamber after the RRs section, i.e. upstream
205 and downstream of the heated zone, respectively, as well as the others 9 TCs which are inserted into
206 the RRs block. For these 9 TCs, installed behind the 2 mm thick target area, see **Figure 4b**, the sensible
207 zone was inserted into dedicated housings, nominally put in contact with the back (wetted) surface
208 of the heated target, with only a gap positioning uncertainty of 0.6 mm, see the inset in **Figure 2**.
209 Therefore, their readings contain some uncertainty as it is not known exactly if each thermocouple
210 measuring tip only touches the copper RRs, the air or both at the same time. A sketch with the
211 reference number for the TCs installed on the sample is reported in **Figure 4a**. Unfortunately, the TC#4
212 and TC#11 came out broken from the previous experimental campaign at the Areva NP Technical
213 Centre in 2015 and 2016. In addition, two thermocouples of the K-type were placed at the inlet and
214 outlet of the whole mock-up, respectively, to collect a more realistic air bulk temperature upstream and
215 downstream of the mixing chambers, respectively.
216



217
218 **Figure 3** - Details of the RRs Mock-up welding to the connection pipes of the solar furnace: (a) before welding,
219 (b) after welding, (c) view of the inside of the two connected pipes.
220

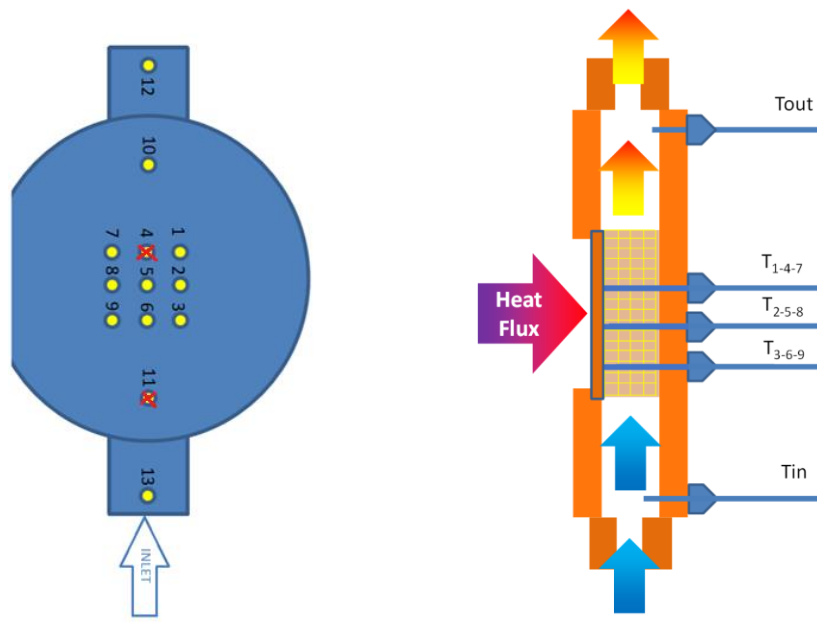

221 (a) (b)
222 **Figure 4** – (a) Sketch map of the thermocouples installed in the sample, with the corresponding identification
223 number; (b) longitudinal section of the mock-up, cutting the sample along its axis.
224

225 The experimental campaign of the mock-up was carried out in September 2019, financed by the
226 European Union’s Horizon 2020 research and innovation program SFERA III, in the 0.6 MW_{th} High-
227 Flux Solar Furnace (SF60) at the Plataforma Solar de Almeria (PSA), which belongs to the Department
228 of Energy of the Centro de Investigaciones Energéticas, Medioambientales y Tecnológicas (CIEMAT),
229 a public research organization under the Spanish Ministry of Economy and Competitiveness
230 (CIEMAT, 2019).

231 The SF60 operates since 1991, consisting of a 120 m² flat heliostat that reflects the solar beam onto
232 a 100 m² parabolic concentrator which, in turn, concentrates the incoming rays on the focus of the
233 parabola, where the testbed is placed. A test table movable on three axes is used to place the mock-
234 up with great precision in the focal area. When these components are operating with the shutter fully
235 opened (100%) and a Direct Normal Irradiance (DNI) of 1000 W/(m² K), a gaussian shaped solar heat

236 flux with a peak irradiance at the focus of about 3 MW/m^2 , a total power of 69 kW and a focal diameter
237 of 26.2 cm occur (CIEMAT, 2019). The SF-60 focal diameter is quite higher than the external diameter
238 of the target of the RRs mock-up, which is only 4.5 cm. Since the Raschig Rings block is located only
239 below the target area of the sample to remove the high heat flux, an alumina sheet was put in place to
240 act as a shield for the sample and block part of the concentrated flux reflected by the parabolic
241 concentrator. A hole was made into the Alumina sheet with a diameter of 38 mm, smaller than the target
242 diameter (45 mm), to avoid the solar rays with the highest solid angle with respect to the target area to
243 reach the circular crown of the mock-up instead. **Figure 5a** and **Figure 5b** show a side and front view
244 of the Alumina Shield, while **Figure 5c** shows its back view.
245

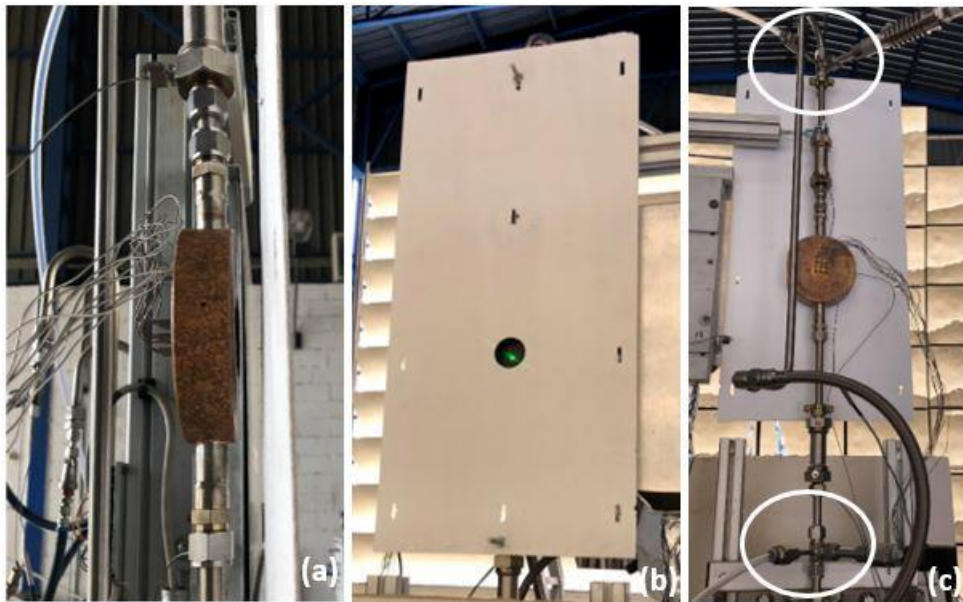

246

247 **Figure 5** - Alumina shield, (a) side view, (b) frontal view, (c) back view: differential pressure taps positioning.

248

249 The final testing circuit, represented in a sketch in **Figure 6**, included primary and secondary
250 loops, with the main following components:

- 251 • A 7.5 kW air compressor needed to increase the air pressure of the entire circuit to the value of
252 10 bar (absolute pressure). The circuit is open, as it sucks air from the ambient;
- 253 • A cooler needed to cool down the hot air coming from the primary mock-up test circuit. The
254 cooling working fluid is the water pumped by the pump from the secondary circuit;
- 255 • A pump (HP -1) needed to pump the water into the secondary circuit. The pumped water goes
256 into the cooler and into some pipes placed underneath the white table where the radiometer is
257 located, in order to refrigerate it;
- 258 • Control valves needed to adjust and control the flow of both air and water into the different
259 pipes;

260

261 Beside the thermocouples mounted on the mock-up, the instrumentation installed in the
262 experimental apparatus included:

- 263 • A flow-meter needed to check that the air flow-rate during each test remains constant and close
264 enough to the target value. Its nominal accuracy can be split in a baseline component, which is
265 $\pm 0.1\%$ of the full scale of the instrument (1650 l/m), and in a variable component, equal to $\pm 0.5\%$
266 of the actual flowrate reading. Additionally, another $\pm 0.1\%$ of the full-scale error is to be added
267 due to some uncertainty related to the control stability, plus another $\pm 5 \text{ mbar}$ as the instrument
268 can only read a variation of 10 mbar. In the case of reading for a test duration of few minutes,
269 the uncertainty related to the full scale increases up to 2%, while most accurate measurements
270 require 30 minutes at least;

- 271 • A differential pressure drop sensor needed to measure the pressure drop across the RRs Mock-up. A PRE-28 transmitter was used, with an accuracy of $\pm 0.40\%$ of the actual reading, plus
 272 another $\pm 0.2\%$ /year instability error, which returns an additional uncertainty of $\pm 1.4\%$, as the
 273 instrument has been operating for 7 years at the PSA. In addition to this, another $\pm 0.3\%/10^\circ\text{C}$
 274 should be added to the total error to take into the effect of the warm air, bringing the total value
 275 to a global accuracy of $\pm 2.40\%$. Note that, starting from the measured pressure drop across the
 276 testing section, which includes also the major and minor losses across the piping and connection
 277 at both ends of the mockup, see **Figure 5c**, it is possible to compute the experimental “net”
 278 pressure drop across the sample;
 279
 280 • A pyrhelimeter, for the instantaneous DNI in W/m^2 , needed to check if the operating conditions
 281 were suitable (almost constant DNI) to test;
 282

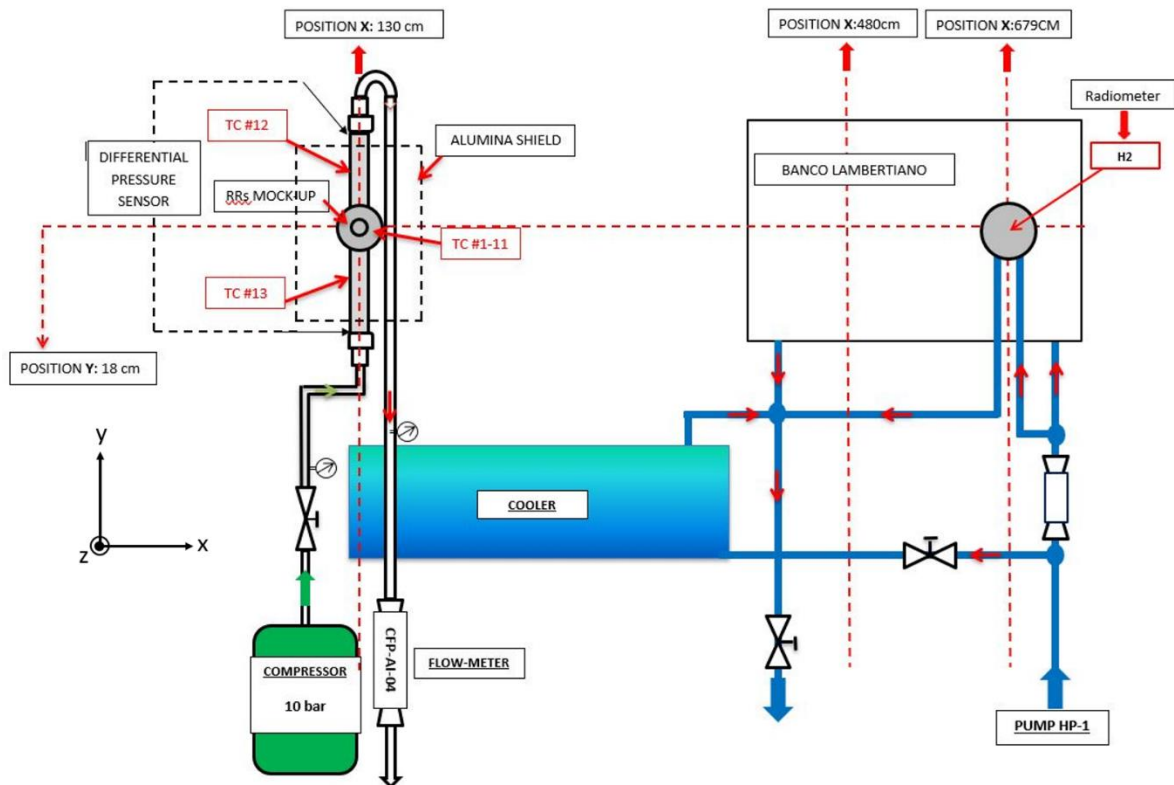

283
 284 **Figure 6** - Sketch of the hydraulic circuit where the sample was inserted for the tests at the PSA.
 285

- 286 • A radiometer needed to measure the amplitude of the solar peak flux. To estimate the peak heat
 287 flux, the target in the focus of the parabolic collector is moved from the sample to a Lambertian
 288 target, through the movement of the mobile testbed. The radiometer adopted at the SF60 has an
 289 accuracy of $\pm 3\%$ (Ballestrin et al., 2003). The incident heat flux, used as boundary condition
 290 in the computational model, can be then calculated according to the Gaussian distribution (Roldán
 291 and Monterreal, 2014) reported in Eq.(1).

$$\varphi = \varphi_{peak} \cdot e^{-0.5 \left[\left(\frac{x}{s_x} \right)^2 - \left(\frac{y}{s_y} \right)^2 \right]} \quad (1)$$

292 where φ_{peak} is the concentrated solar radiation estimated at the focus point (i.e. the peak value)
 293 and s_x and s_y are the standard deviations, in x and y direction respectively, both equal to 0.064
 294 (Ballestrin et al., 2003). On top of the given accuracy, other possible sources of inaccuracies may
 295 occur: the peak load could change while the measurement panel shifts from the sample to the
 296 radiometer, for instance, or the local focus of the flux on the sample could be, instantaneously,
 297 in a different position since the heliostat, tracking the sun, is moved by the wind coming from

298 any possible direction. Unfortunately, it is not possible to quantify this error, which has then
299 been neglected.

300 3. Test campaign and experimental results

301 During the two weeks experimental campaign, two different kinds of tests were performed.
302 First, pure hydraulic tests were run by measuring the pressure drop across the sample with different
303 flowrate and, then, thermohydraulic tests were carried out by irradiating the target area of the sample
304 with different heat flux at several flowrates and collecting the readings of the thermocouples in it.

305 Pure hydraulic tests were performed to investigate the hydraulic properties of the porous media
306 (i.e. the Raschig Rings block) placed below the target area of the sample when using air as a working
307 cooling fluid. The main purpose was to measure the hydraulic characteristic of the mock-up, to
308 provide additional data with respect to those measured on a cylindrical sample in (Allio et al., 2020)
309 for the validation of our computational model. The hydraulic tests have been performed with no heat
310 flux incoming into the target area of the sample (typically during cloudy days), with an inlet pressure
311 of ~10 bar, an air flow rate ranging from 200 NI/min up to 800 NI/min and an ambient temperature
312 of about 20°C. After letting the flowmeter running for at least 30 minutes, in order to minimize as
313 much as possible its reading uncertainty, the tests have been performed according to the following
314 guidelines to minimize the experimental uncertainties:

- 315 • The duration of the test should be ~ 2 minutes;
- 316 • The pressure drop measurements should vary of $\pm 2.40\% + 5$ mbar, at maximum;
- 317 • The flow-meter readings should vary of $\pm 2.00\%$, at maximum.

318 To process the hydraulic experimental data, a time average of the data measured for each flow rate
319 value has been performed. The total raw averaged pressure drop measurement, reported in **Table 1**,
320 has been offset subtracting the pressure drop deriving from both the minor and major pressure loss
321 of the circuit between the two pressure taps, as sketched in **Figure 7**, evaluated by a simple
322 axisymmetric 2D CFD model. The result is reported in the column “mock-up pressure drop” in **Table**
323 **1**, showing that, unfortunately, the largest part of the pressure loss occurs outside of the mock-up,
324 resulting in a poor measurement accuracy, especially at the lowest flow rates.

325

326 **Table 1** - Summary of the hydraulic tests performed during the experimental campaign.

Test ID	Flow rate	Total pressure drop	Mock-up pressure drop
	[NI/min]	[mbar]	[mbar]
#H1	200 ± 4.3	10 ± 5.2	5.7 ± 5.2
#H2	300 ± 4.8	20 ± 5.5	7.8 ± 5.5
#H3	400 ± 5.3	40 ± 6.0	19.2 ± 6.0
#H4	500 ± 5.8	60 ± 6.4	26.9 ± 6.4
#H5	600 ± 6.3	90 ± 7.2	41.8 ± 7.2
#H6	700 ± 6.8	130 ± 8.1	62.7 ± 8.1
#H7	800 ± 7.3	180 ± 9.3	92.7 ± 9.3

327

328 To investigate the thermal properties of the Raschig Rings block, thermal-hydraulic tests were
329 performed in “quasi-steady-state” tests, because of the intrinsic variability of the solar heat source.
330 First, the shutter was regulated to obtain the desired peak heat flux. Then, the mobile test table was
331 moved to place the sample under the focus point. Before the radiometer was positioned a second time
332 under the focus to measure the peak heat flux to compare it with the initial one, to be sure that the
333 heat flux had not varied during the test, the tests were kept running until all the temperature traces
334 got to a quasi-steady state, established based on the following criteria:

- 335 • Minimum duration of the quasi-steady state test of 2 minutes;

- 336 • Maximum variation of the readings of all the thermocouples within $\pm 3.00\%$, as this is the major
337 instrumentation error;
- 338 • Maximum variation of the flow-meter reading within $\pm 2.00\%$;
- 339 • Maximum variation of the peak heat load within $\pm 3.00\%$ (that translated into a check on the
340 radiometer output before and after the test is performed);
- 341 • Check on the wind velocity, which makes the focus position significantly unstable: for safety
342 reasons, the limit provided by the PSA staff of the wind velocity which forced to move back the
343 heliostat in horizontal positions (and therefore to stop any test), was set to the value of 30 km/h.
344

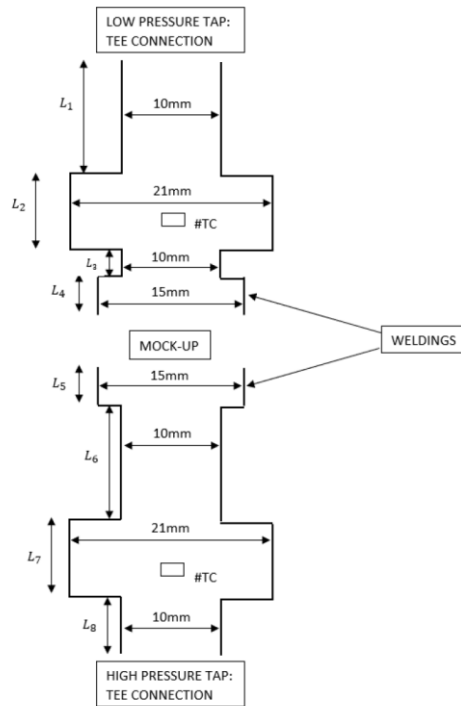

345
346 **Figure 7** – Sketch of the primary loop connections to the sample, highlighting the main geometrical dimensions
347 relevant for the evaluation of the major and minor losses. For the test of the mock-up: $L_1 = L_6 = 12$ cm, $L_2 = L_7 =$
348 8 cm, $L_3 = 3$ cm, $L_4 = L_5 = 4$ cm, $L_6 =$ cm.

349
350 A summary of all the thermo-hydraulic tests considered in the present analysis, after the above-
351 mentioned checks, is reported in **Table 2**.
352

353 **Table 2** - Summary of all the thermo-hydraulic tests performed during the experimental campaign.

Date	Test ID	Flow rate	Inlet Pressure	Ambient Temperature	Peak Heat Flux	Shutter Aperture
dd/mm/yy		[l/min]	[bar]	[°C]	[kW/m ²]	[%]
13/09/2019	#1-TH1	300 ± 4.8	9.7	20.1 ± 1.5	107 ± 3.2	11.5
13/09/2019	#2-TH1	200 ± 4.3	9.7	21.0 ± 1.5	112 ± 3.4	11.5
16/09/2019	#1-TH2	100 ± 3.8	9.6	22.3 ± 1.5	131 ± 3.9	16.0
16/09/2019	#2-TH2	100 ± 3.8	9.6	27.5 ± 1.5	308 ± 9.2	26.0
16/09/2019	#3-TH2	200 ± 4.3	9.7	27.6 ± 1.5	502 ± 15	32.5
16/09/2019	#5-TH2	100 ± 3.8	9.6	29.1 ± 1.5	500 ± 15	31.0

16/09/2019	#6-TH2	300 ± 4.8	9.7	29.4 ± 1.5	702 ± 21	40.0
17/09/2019	#1-TH3	300 ± 4.8	9.7	25.0 ± 1.5	500 ± 15	25.5
18/09/2019	#2-TH4	300 ± 4.8	9.7	27.0 ± 1.5	298 ± 9.0	21.5
19/09/2019	#1-TH5	200 ± 4.3	9.6	23.6 ± 1.5	299 ± 9.0	24.2
19/09/2019	#2-TH5	200 ± 4.3	9.6	31.1 ± 1.5	727 ± 22	39.4
19/09/2019	#3-TH5	200 ± 4.3	9.6	33.2 ± 1.5	102 ± 3.1	7.00

354

355

356

357

358

359

360

361

362

363

364

365

366

367

368

369

370

371

372

373

374

375

376

A summary of the measured temperature increase ΔT_{in-out} across the mock-up, for the different flow and heat load conditions, is reported in **Figure 8**, showing that for a given heat load, ΔT_{in-out} is inversely proportional to the flow rate, and for a given flow rate ΔT_{in-out} is directly proportional to the heat load, as expected. Note that the uncertainty associated with each bar comes from the inaccuracy of the thermocouple ($\pm 1.5^\circ\text{C}$), plus the standard deviation calculated from the two minutes or more “quasi-steady-state” period needed to validate the test.

When the calorimetry is performed using the measured ΔT_{in-out} , assuming steady-state condition, the picture represented in **Figure 9** is found: when plotting the absorbed power as a function of the incident power in all cases the thermal efficiency, defined as the ratio between the two quantities, is around 50%. At the lowest flow rate, the efficiency is slightly below 50%, while it is slightly above that value, and comparable within the error-bars for the two highest flow rates. The lower absorbed power for the lowest flow rate can be explained considering that the highest temperature values reached for the lowest flow rate, see **Figure 8**, drives higher losses that, for a given incident power, reduce the absorbed power if compared to the case at highest flow rates.

The overall readings of the thermocouples in the RR block are condensed in **Figure 10** (some of the TC were malfunctioning during certain periods of time, namely TC #6 and TC #8, so that their readout has been omitted when their signal was completely flat). It is clear that the temperature measured by the TC increases along the fluid path due to the heating from the target. Unfortunately, the TC #4, which is the thermocouple located under target downstream, on the symmetry plane, that should correspond to the highest temperature, was broken. Moreover, the expected left-right symmetry in the temperature measurement is only roughly met, but that could be due to the uncertainty in the positioning of the TC heads, see also above.

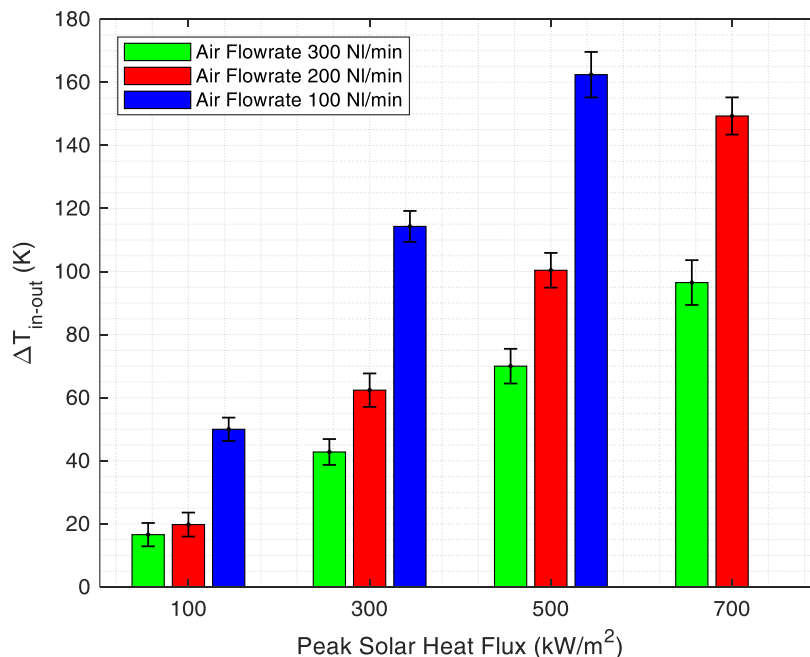

377

378
379

Figure 8 – Temperature difference ($T_{\text{outlet}} - T_{\text{inlet}}$) measured across the sample at different values of the peak heat flux, for the different tests values of the air flow rates.

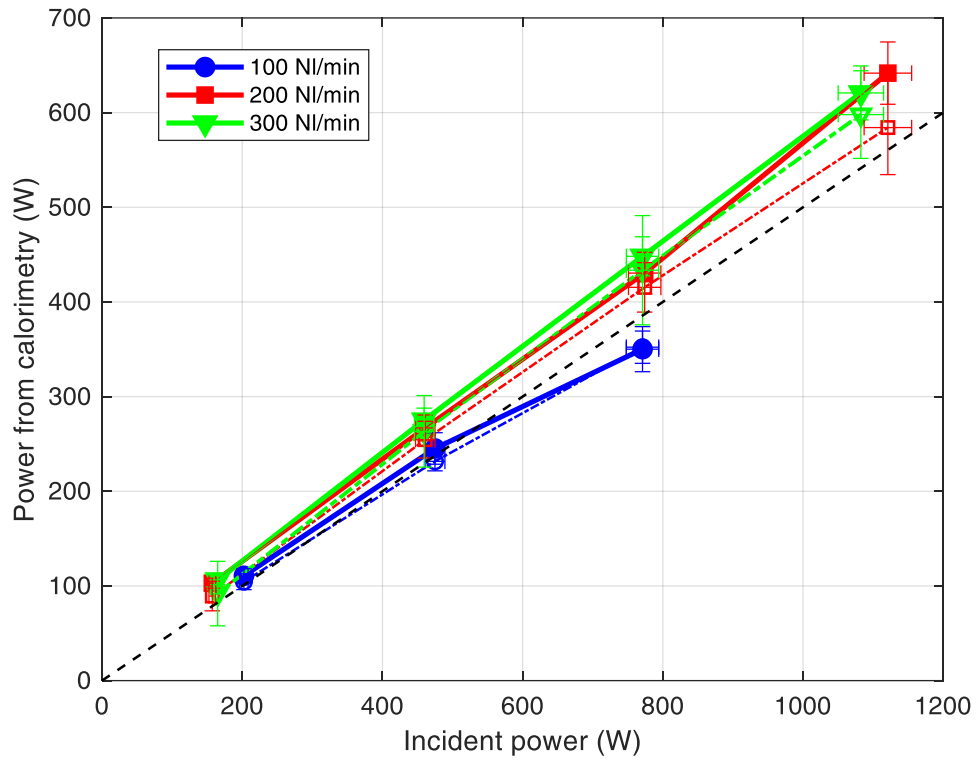

380
381
382
383
384

Figure 9 – Power computed by calorimetry as a function of the incident power, for the different tested flow rates: experimental values (solid lines and symbols) and computed values (thin dash-dotted line with open symbols). The dashed line represents the 50% efficiency.

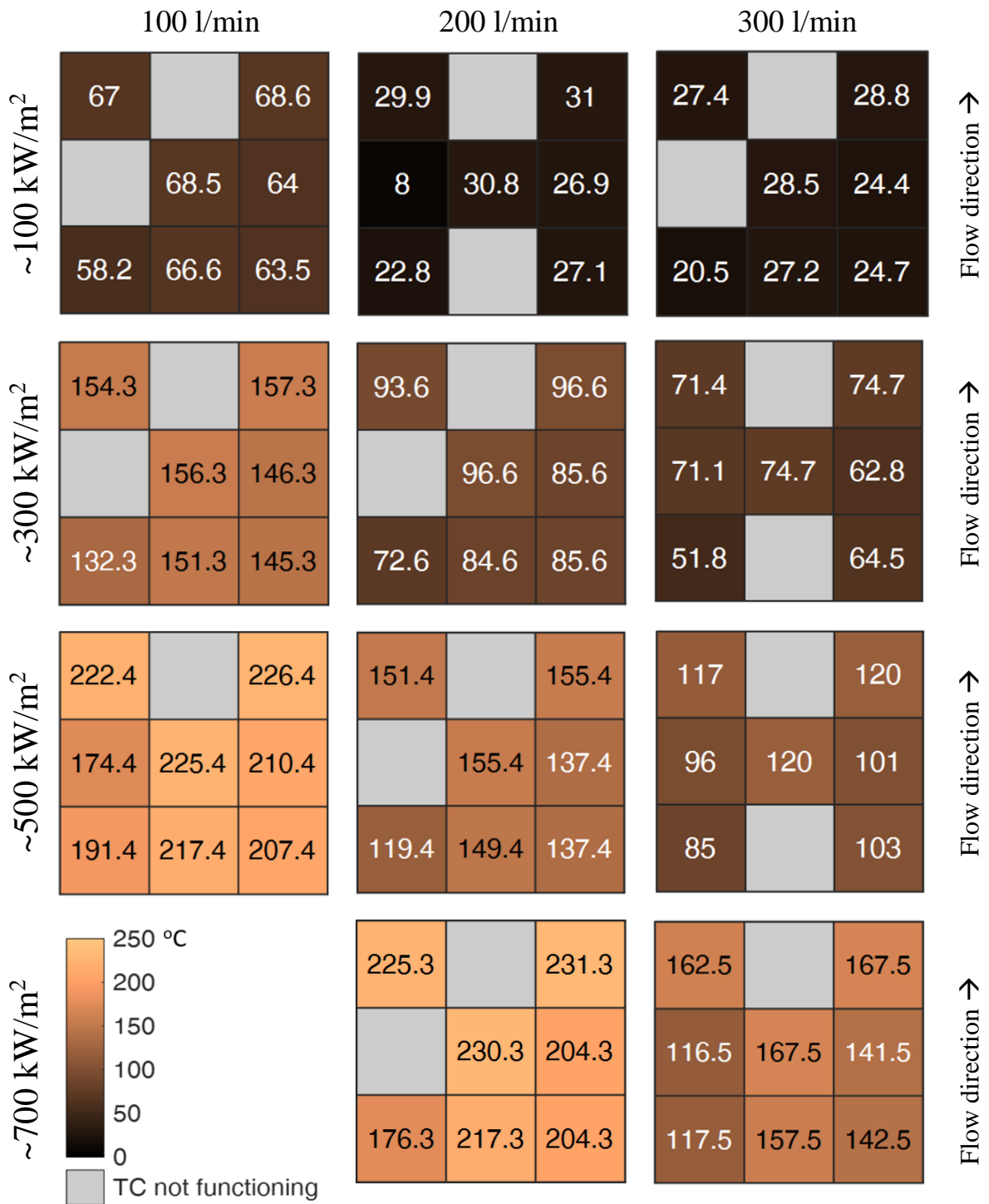

Figure 10 –Temperature increase (with respect to the air inlet conditions) measured in the RR block during the thermal-hydraulic tests in Table 2.

389 4. Development and validation of a numerical model for the mock-up

390 4.1. Simulation model and setup

391 The 3D CFD steady-state conjugate heat transfer problem with a non-uniform heat flux of the
392 mock-up model has been solved with the aid of the commercial software STAR-CCM+ v.10 and v.14
393 (CD-adapco, 2018).

394 The geometry used in the simulations is shown in **Figure 11** and will be used for both pure
395 hydraulic and thermohydraulic simulations. Thanks to the symmetry of geometry, boundary
396 conditions and thermal driver, it has been possible to reduce the domain to just half of it, thus
397 significantly reducing the computational cost of each simulation (Bertinetti et al., 2018).

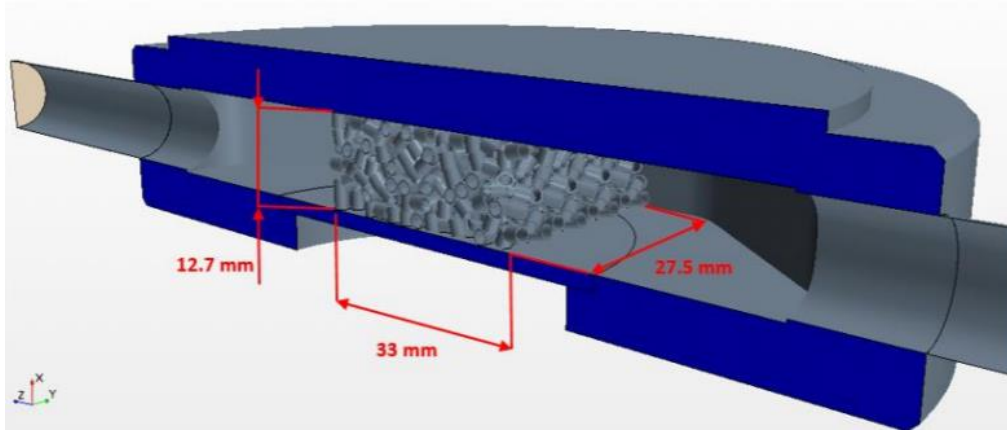

398

399 **Figure 11** - View of the simulated domain.

400

401 The computational domain is subdivided into two regions, one being the solid of the sample
402 (Glidcop) and the other one being the fluid (air). The solid volume of the 11 thermocouples is not
403 included in the simulations.

404 The driver for the simulations of the thermal-hydraulic tests is the heat flux, having a Gaussian
405 distribution as in Eq. (1), applied to the circular target area (external surface) of the mock-up. The
406 peak flux ranged from 100 kW/m² up to 700 kW/m², depending on the simulation. The Gaussian
407 function (see Eq. 1) is applied in such a way that the peak of the flux corresponds to the center of the
408 target area, while the minimum value corresponds to the border of the same area. The absorptivity
409 coefficient for the solar radiation α was set to 0.64 (Toolbox, 2019), applied to the target area of the
410 sample, for all the simulations. The surface heat load is then let free to diffuse in the mock-up
411 envelope, as well as in the porous medium.

412 The fluid boundary conditions for all simulations include the inlet mass flowrate and the inlet
413 air temperature T_{in} , both depending on the test simulated. For the outlet section, a uniform value of
414 the pressure p_{out} was set equal to 10 bar.

415 The solid boundary conditions for the thermal-hydraulic simulations include thermal losses by
416 free convection and radiation to the environment, applied to every surface facing the open
417 environment. The convective losses are computed according to Newton's cooling law, as a function
418 of the wall surface temperature (computed by CFD), the ambient temperature and the heat transfer
419 coefficient. The ambient temperature was monitored during the test sessions, while the heat transfer
420 coefficient has been estimated using the empirical correlation in Eq. (2) (Incorpera et al, 2006);

$$Nu = \left[0.825 + \frac{0.387 \cdot Ra^{1/6}}{\left[1 + (0.492/p_r)^{9/16} \right]^{8/27}} \right]^2 \quad (2)$$

421 The radiative heat losses computed using an emissivity $\varepsilon = 0.78$ (Toolbox, 2003) are also applied
422 on every dispersing surface.

423 For the solid region, the steady-state heat conduction equation, with temperature-dependent
424 thermophysical properties, is solved not only for the external envelope of the mock-up but also for
425 each RR. The discrete element model (DEM) approach was adopted to generate the geometry random
426 distribution of rings, as done in previous works on the same topic (Allio et al., 2020), (Savoldi et al.,
427 2018). DEM is typically used for complex modeling of particulate material behavior in chemical, food,
428 metallurgical, mining, and other industries. It is used for instance to simulate deposition of particles
429 under gravity, particles mixing applications, particle-fluid interaction to trace the granular material
430 in a continuous fluid flow. Notwithstanding its great potential, the DEM is also very suited to just
431 generate complex geometrical domains where many particles with the same geometrical
432 characteristics are present, without any particle motion during the simulation of interest. The RR
433 matrix generation procedure consisted of three steps: 1) generation of the volume of the RR matrix,
434 2) actual DEM simulation, consisting of a time-dependent study in which, at each time step, a certain
435 number of solid cylindrical particles of the same outer size of the RR, were injected into the volume
436 where the porous matrix should be built, 3) replacement of the solid cylinders by the hollow
437 cylinders. The resulting computational domain is shown in **Figure 11**. For the RR matrix, the effective
438 value of the heat conductivity is set to 2600 W/m/K (Bertinetti, 2019), which is quite larger than the
439 Glidcop or copper conductivity, because it accounts for the fact that the contact between the brazed
440 rings is much wider than the contact point present in the model. For the Glidcop density and specific
441 heat, the copper values are adopted. Once the computational domain is built, including the solid
442 volume of the RRs, the conjugate heat transfer problem is solved, simulating not only the solid matrix
443 but also the flow field within them.

444 As far as the selection of computational models is concerned, for the fluid region, where the air
445 turbulent flow is compressible and all its thermo-physical properties are temperature-dependent, a
446 segregated flow solver was chosen. The flow is in turbulent conditions in the inlet/outlet pipes for all
447 the simulated values of the flow rates, with the value of the Reynolds number (Re) varying between
448 2.4×10^4 and 1.1×10^5 . The flow conditions in the RR region is evaluated looking at the so-called
449 “pellet Reynolds number” Re_p , which is defined using the mean velocity at the inlet of the RR region
450 and the characteristic length computed as the diameter of the sphere equivalent to the volume of a
451 single ring. When $Re_p > 600$ turbulent conditions are met (Allio et al., 2020); in the case at hand, Re_p
452 varies between 600 and 2400.

453 Following the Reynolds-Averaged Navier-Stokes approach with two-equations to deal with
454 turbulence, the $k-\omega$ SST (Menter) turbulence closure (Malalasekera and Versteeg, 2007) was selected
455 here, with an all- y^+ wall treatment, as already successfully done in (Allio et al., 2020). It is well known
456 that the $k-\epsilon$ model is unsatisfactory in predicting separating and rotating flows in the near-wall
457 region, resulting in an overestimation of turbulent kinetic energy κ and of the turbulent viscosity; this
458 is mainly due to the empirical nature of the constants used in the equation for the dissipation rate ϵ
459 (Mohammadi and Pironneau, 1994). On the other hand, the $k-\omega$ model has improved performance in
460 modeling the boundary layers under adverse pressure gradients, which is a critical feature of the case
461 under study: indeed, the presence of the RR induces a tortuous flow pattern for the coolant. Our
462 selected turbulence model, the SST-Menter $k-\omega$ is able to work as a standard $k-\omega$ in the near-wall
463 region, inside the RR block, and as the $k-\epsilon$ model in the main core of the fully turbulent region at the
464 inlet/outlet of the RR block. The energy conservation was also solved with a segregated fluid
465 temperature model.

466 The mesh for the simulations is a polyhedral cells-based mesh with around 8.9 million of
467 elements. It is built with a general base size of 1.2 mm that has been refined to the value of 0.7 mm
468 for the fluid region and down to the value of 0.2 mm for the portion of the volume that contains the
469 Raschig Rings. A number of 5 prism layers has been chosen for the mesh. This final mesh has been
470 chosen through a grid independence study and a total computational inaccuracy of $\sim 0.5\%$ is obtained
471 with a Richardson extrapolation (Ferziger and Peric, 2002). A selection of the grid independence
472 analysis results is shown in **Figure 12**. The analysis has been performed computing the main thermal
473 and hydraulic quantities of interest using three different meshes. In the abscissa of the plots a
474 normalized cell base size computed using the total number of the cells is reported. A generic view of

475 the meshed geometry utilized for the simulations is shown in **Figure 13a**, while in **Figure 13b** a detail
 476 of the mesh in the RRs region is shown.
 477

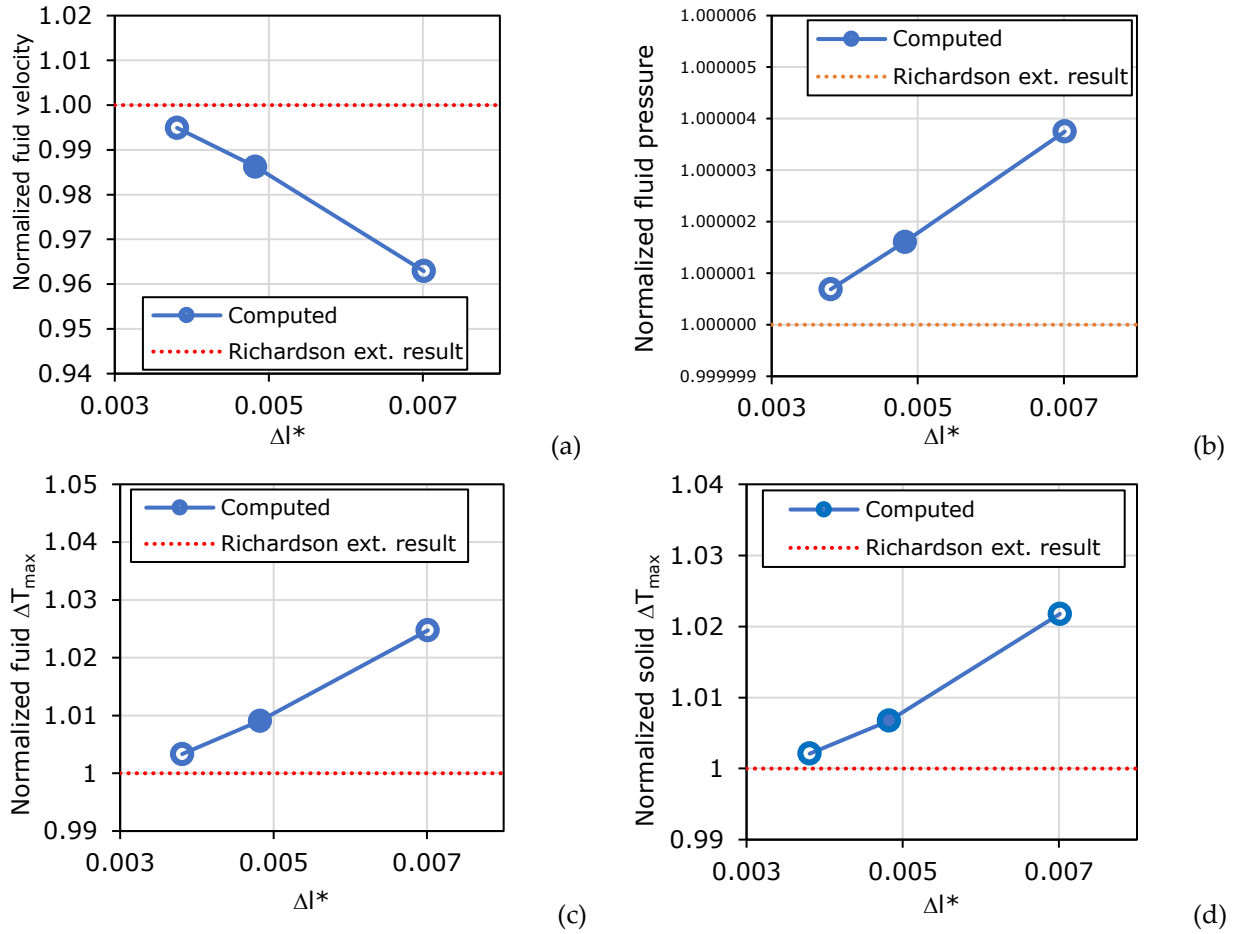

478 **Figure 12** - Grid independence analysis varying the base size of the mesh, for a flow rate of 200 NI/min and a
 479 heat flux of 500 kW/m². (a) Mean velocity in the outlet manifold (section at $z = 35$ mm); (b) pressure in the outlet
 480 manifold (section at $z = 35$ mm); (c) maximum temperature difference of the fluid with respect to the inlet
 481 condition; (d) maximum temperature difference of the solid with respect to inlet condition (d) All the quantities
 482 are normalized to the asymptotic solution evaluated through a Richardson extrapolation. The filled circles
 483 highlight the mesh selected for the simulations in the present analysis. $\Delta l^* = \sqrt[3]{1/N_{cell}}$ is the normalized base
 484 size of the grid cells calculated on the total number of the mesh cells.

485
 486 The computational cost of the complete model can be subdivided in the cost for the generation
 487 of the porous matrix, through the DEM simulation, the cost for the mesh generation and the cost for
 488 the actual simulation. The DEM generation weighs about 5% of the total cost, while the mesh
 489 generation, particularly challenging in the porous region, weighs 10% of the total. The thermal-
 490 hydraulic simulation can be further subdivided into pure hydraulic simulation, which represents
 491 about 5% of the total cost and requires about 3000 iterations to achieve convergence of fluid physics,
 492 and the conjugate heat transfer simulation, with thermal driver and temperature-dependent material
 493 properties, which represents the remaining 80% of the cost and requires about 35000 iterations to
 494 achieve a satisfactory convergence.

495 4.2. Hydraulic characteristic

496 The accuracy of a similar CFD model in reproducing the pressure drop across a cylindrical mock-
 497 up of a gyrotron cavity has been recently demonstrated using water as the process fluid (Allio et al,

498 2020). The suitability of the numerical model in reproducing the measured pressure drop across the
499 planar mock-up in the case of a compressible fluid (air) is assessed here. Note that also a limited
500 number of pressure drop tests performed on the same sample at the AREVA and THALES premises,
501 respectively, using water as process fluid, were also available to us (Rozier, 2015), so that a
502 comprehensive validation of the numerical model as far as its capability to compute the hydraulic
503 characteristic of the flow through the RR region is possible here, after the detailed analysis of the
504 computed flow and pressure field.

505

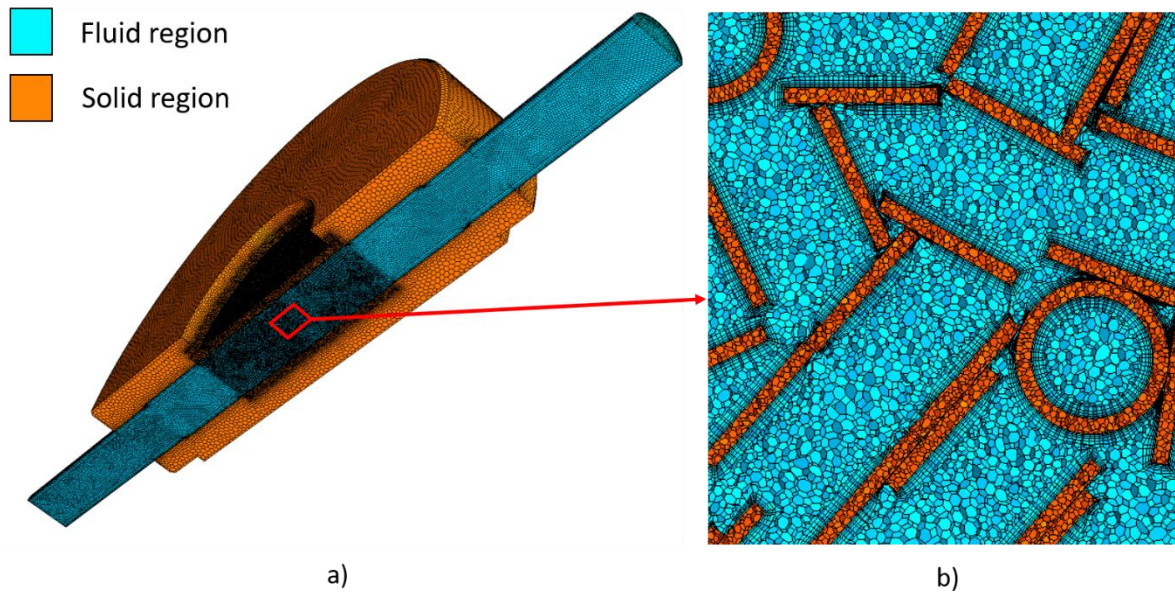

506

507 **Figure 13** - Mesh view, (a) general view; (b) detail of the mesh in the RRs region.

508

509 The analysis of the flow field in random packing structures has been the topic of several
510 experimental and numerical studies, as it has a relevant effect on pressure drop and heat transfer
511 enhancement. The velocity scene is presented in **Figure 14**, showing strong inhomogeneities in both
512 directions and the generation of primary vortices at the end of the inlet pipe. In addition, the detail
513 on the RRs region reveals a dependency of the velocity on the orientation of the RRs: stagnation points
514 occur when the ring is perpendicular to the main flow, while a parallel orientation produces a
515 significant increase in the local velocity.

516

517

518

519

520

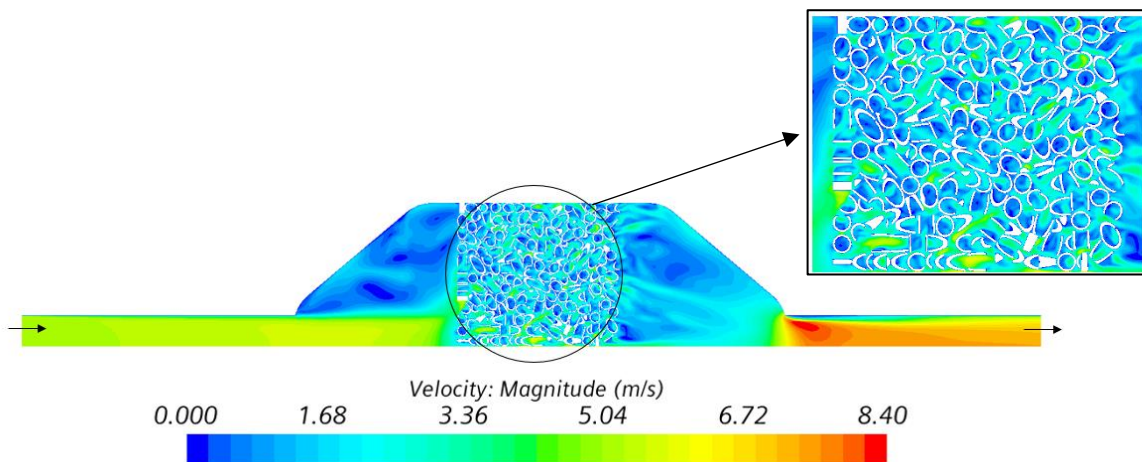

521

522 **Figure 14** – Computed flow field on the y-z plane passing through the axis of the inlet/outlet pipes, for the
523 simulation at 300 l/min and 500 kW/m². Inset: zoom of the flow field in the RR region.

524

525 As a consequence of the generation of stagnation points, the number of streamlines that enters
 526 the RRs region is higher than the one exiting it, as reported in **Figure 15**, where the streamlines are
 527 associated with the scalar velocity. The vortex in the entrance region is highlighted as well.
 528 Furthermore, the pattern of the fluid particles appears to be tortuous, increasing the pressure drop
 529 across the RRs region. The pressure field in the y-z direction is presented in **Figure 16**, showing the
 530 drawback of random packing beds: the pressure decreases as the air flows inside the RRs, for a total
 531 drop of approximately 1000 Pa for the flow rate of 300 l/min. The RRs block accounts for 82% of that.

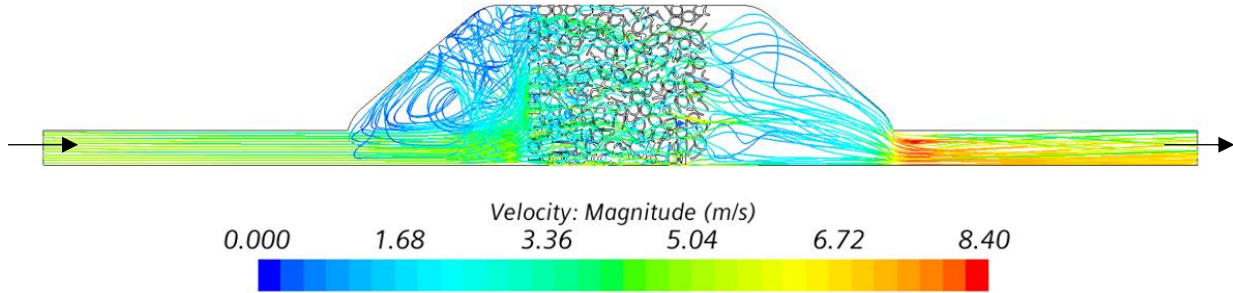

532 **Figure 15** – Computed streamlines of the fluid on the y-z plane passing through the axis of the inlet/outlet
 533 pipes, for the simulation at 300 l/min and 500 kW/m².
 534
 535
 536

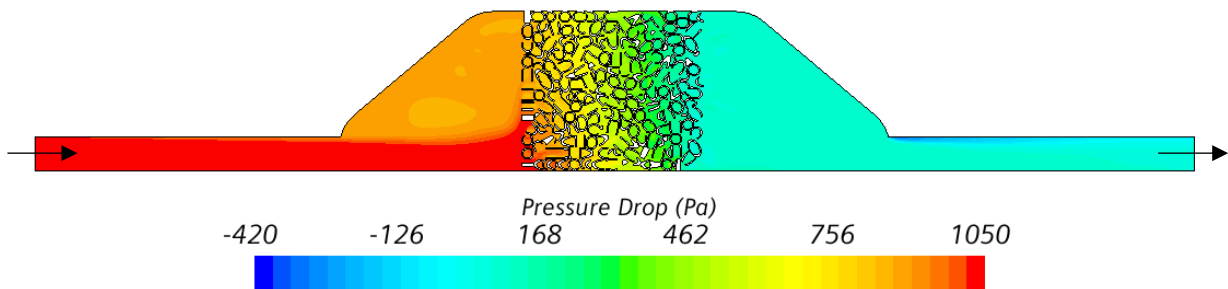

537 **Figure 16** - Computed pressure drop on the y-z plane passing through the axis of the inlet/outlet pipes, for the
 538 simulation at 300 l/min and 500 kW/m².
 539

540 The comparison between the experimental and the computed characteristic, represented in
 541 **Figure 17**, shows a very good agreement at mass flow rates below 15 g/s (600 NI/min), while the
 542 computed results tend to underestimate the measurements at the highest values of the measured flow
 543 rate. The error-bar attributed to simulated values resulted from the uncertainty on the flow rate,
 544 combined with the uncertainty due to the porosity of the RR matrix, as discussed in (Allio et al., 2020),
 545 and with the error on the simulated pressure. Note that the quadratic fit in Eq. (3):
 546
 547

$$\Delta p = 0.2351 \cdot \dot{m}^2 + 0.225 \cdot \dot{m} \quad (3)$$

548 where Δp is the pressure drop along the mock-up in mbar, and \dot{m} is the air mass flow rate, perfectly
 549 fits the computed points with $R^2 = 1$. That peculiarity can be qualitatively explained referring to the
 550 theory of the porous media (Bejan, 2013), where Darcy's law describes surface drag through a linear
 551 dependence of the pressure gradient on the (seepage) velocity through a coefficient that depends on
 552 the porous medium permeability. A non-linear (quadratic) term breaks the linear dependence when
 553 the form drag due to the solid obstacles in the porous matrix becomes comparable to the surface drag,
 554 see Eq. (4).
 555
 556

557

$$\nabla p = -\frac{\mu}{K}v - c_F K^{-1/2} \rho_f |v|v \quad (4)$$

558

In Eq (4), ∇p is the pressure gradient, μ and ρ_f are the fluid viscosity and density, respectively, K is the porous medium permeability, c_F is a dimensionless form-drag constant and v is the seepage velocity (i.e., the average velocity taken with respect to a volume of the medium, and not only of the fluid).

562

However, the portion of the mock-up containing the porous medium is limited in extension, while the rest of it contains plane channels, with a non-negligible contribution to the pressure drop, the quantitative use of Eq. (4) to derive, for instance, the RR permeability and the form coefficient is not straightforward.

563

564

565

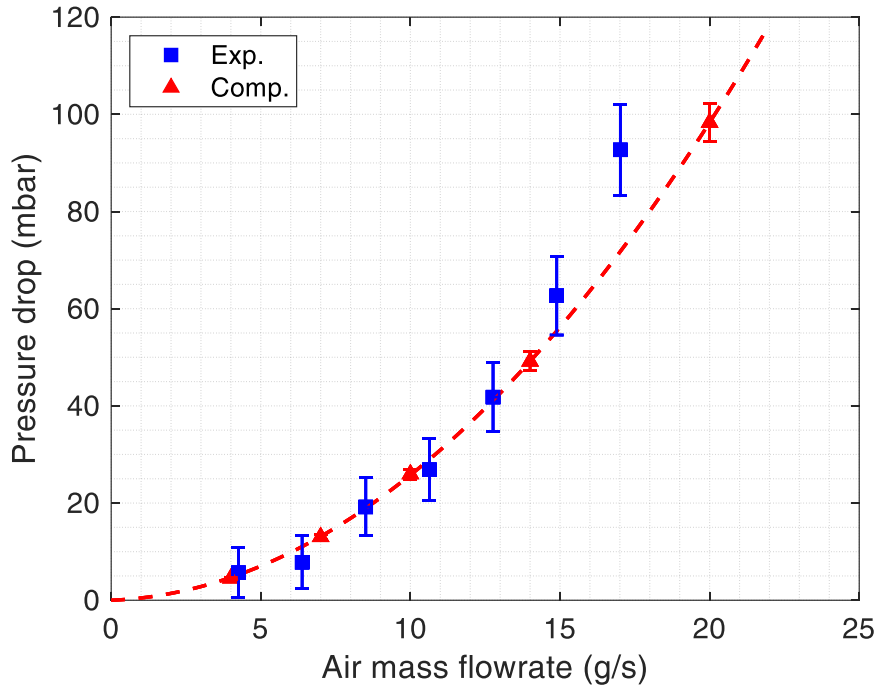

566

Figure 17 – Hydraulic characteristic of the mock-up: experimental (solid squares) vs. computed (solid triangles). The fit of the computed points is also reported (dashed line).

567

568

569

570

To investigate further the behavior of the mock-up at high values of the flow rates, where the simulation deviates from the experimental measurements, we should try to take advantage from the pressure drop measurements which have been performed on the same mock-up at the AREVA and THALES premises, respectively, few years ago. Since those tests have been performed using water as process fluid, a dimensional comparison of the hydraulic characteristic of the mock-up in the different tests is meaningless in view of the very different thermophysical properties of the fluid. A fair comparison could be attempted in terms of the dimensionless quantity (Re , f), where Re is the Reynold number and f is the friction factor, but that would require the introduction of a characteristic length (the hydraulic diameter), whose definition is not trivial for the geometry of the mock-up. For this reason, we use here a reformulation of Re and f , already extensively used in other problems (Rizzo et al., 2012),(Rizzo et al, 2013), where the core flow velocity in the standard definition of Re and f have been substituted by the mass flow rate and no geometrical dimensions are involved. The new pseudo-dimensionless quantities Re^* and f^* are defined in Eqs. (5) and (6), respectively.

571

572

573

574

575

576

577

578

579

580

581

582

583

584

$$Re^* = \frac{\dot{m}}{\mu} \quad (5)$$

585

$$f^* = \frac{\Delta p \cdot \rho_f}{\dot{m}} \quad (6)$$

586

587

588

589

590

591

592

593

594

595

596

597

598

599

600

601

602

Note that Re^* has the dimensions of a length (m) and f^* those of (m^{-4}). The introduction of Re^* and f^* allows the comparison of data obtained using different fluids, without the need of defining a characteristic length. The overall picture of the experimental pseudo-dimensionless pressure drop along with the mock-up, measured in the different experimental campaigns using water and air, is collected in **Figure 18**. Although the error-bar on the water measurement was no available, the comparison between the two different water sets gives an idea of the accuracy of those measurements. The data measured using air show clearly an agreement, within the error bar, with the data measured using water, at least for low Re^* . For the two points in air at highest Re^* , an increasing trend is shown, which is different from the data measured using water, confirming the odd behavior of the measurement data there, already visible in **Figure 17**. Note that the points computed both using water and air are well in agreement with the measured data points in water at high Re^* , and within the error-bar of the measured data points in air at low Re^* . Globally, **Figure 18** confirms the suitability of the numerical model developed here to assess the pressure drop of the mock-up equipped with RR. The model, as far as the hydraulic behavior is concerned, might be used with confidence for the design of a porous tubular cavity receiver prototype with RRs used as a heat transfer matrix.

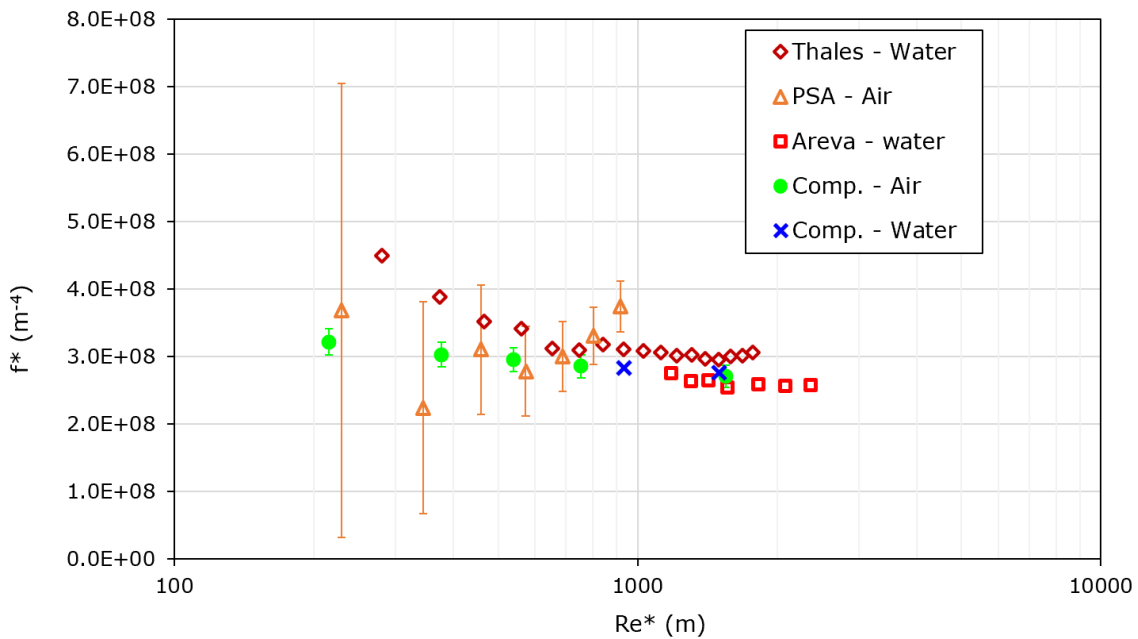

603

604

605

606

Figure 18 – Pseudo-dimensionless hydraulic characteristic of the mock-up: experimental (open symbols) and computed (solid symbols).

607

4.3. Simulation of the Thermohydraulic performance

608

609

610

611

612

613

614

615

The capability of the numerical model to correctly reproduce the thermal driver of the simulations is first cross-checked through calorimetry, involving the overall temperature increase between inlet and outlet. The computed power entering the mock-up is compared in **Figure 9** to the values obtained, for the different tests, from the measured values, showing a very good agreement at any incident power level and air flowrate.

The total amount of the computed heat losses (both radiative and convective) from the mock-up is reported **Figure 19a**, showing the expected increase with the mean target temperature and the expected decrease with the cooling flow rate, which affects the temperature increase at the target for

616 a given heat load level, see the labels in **Figure 19a**. According to the computed results, the total losses
 617 amount to ~ 10% of the incident power.

618 The split of the losses between the convective and the radiative contribution is reported in **Figure**
 619 **19b**, showing that at low temperature the contribution of the two losses is comparable, while the
 620 radiative contribution becomes progressively dominant at higher target values, as expected from its
 621 non-linear dependence on the temperature difference between the hot and cold surfaces. Note that
 622 the losses computed for the simulations at the different flow rates do not overlap, in view of the
 623 different temperature distribution on the entire surface of the mock-up, see below, that the average
 624 target temperature cannot account for.

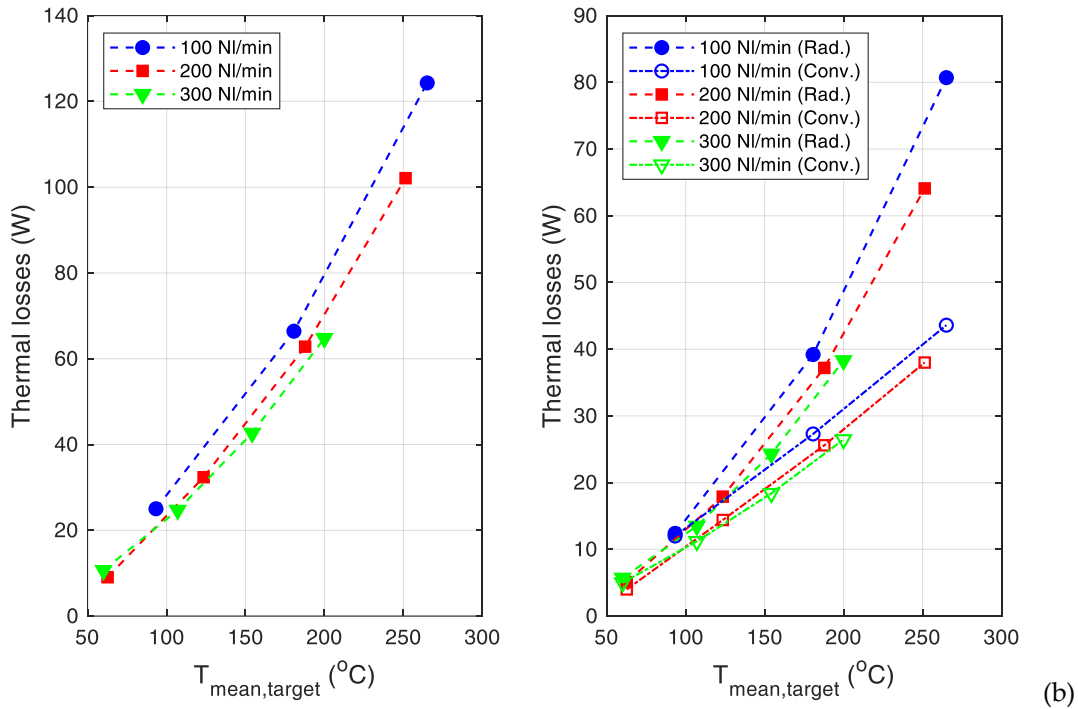

625 (a) (b)
 626 **Figure 19** - Computed thermal losses from the mock-up, as a function of the mean temperature of the target,
 627 for the different tested flow rates. (a) Total losses, (b) Radiative and convective losses.

629 For a single test (300 NI/min and 500 kW/m²), the computed temperature map in all the solid
 630 components of the mock-up is reported in **Figure 20**, showing that the hot spot is not centered in the
 631 target but tends to slide downstream because of the direction of the active cooling in the mock-up.
 632 The average temperature of the mock-up envelope out of the target region is significantly above the
 633 ambient temperature, demonstrating a strong role of parasitic conduction in the metallic structure
 634 around the target. Moreover, just one layer of RRs, in direct thermal contact to the target, significantly
 635 contributes to the heat removal.

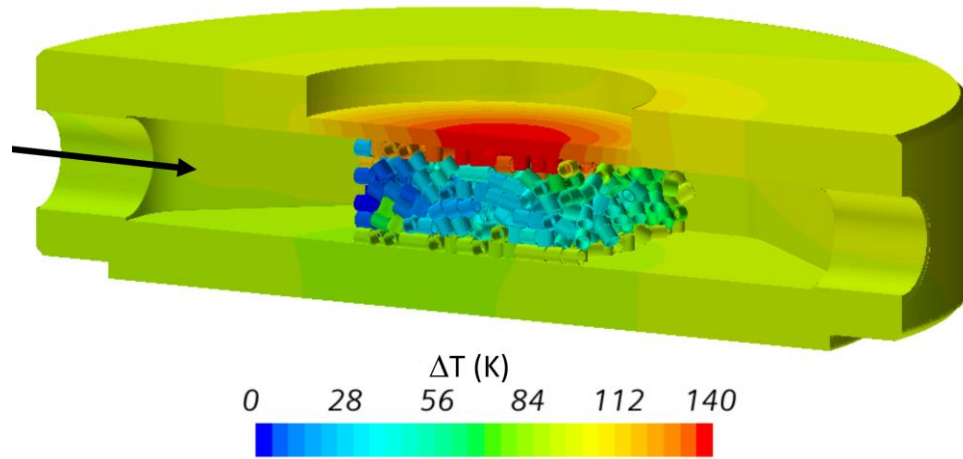

636
637
638

Figure 20 - Computed field of the solid temperature increase with respect to the ambient value on different surfaces, for the case at 300 NI/min and 500 kW/m².

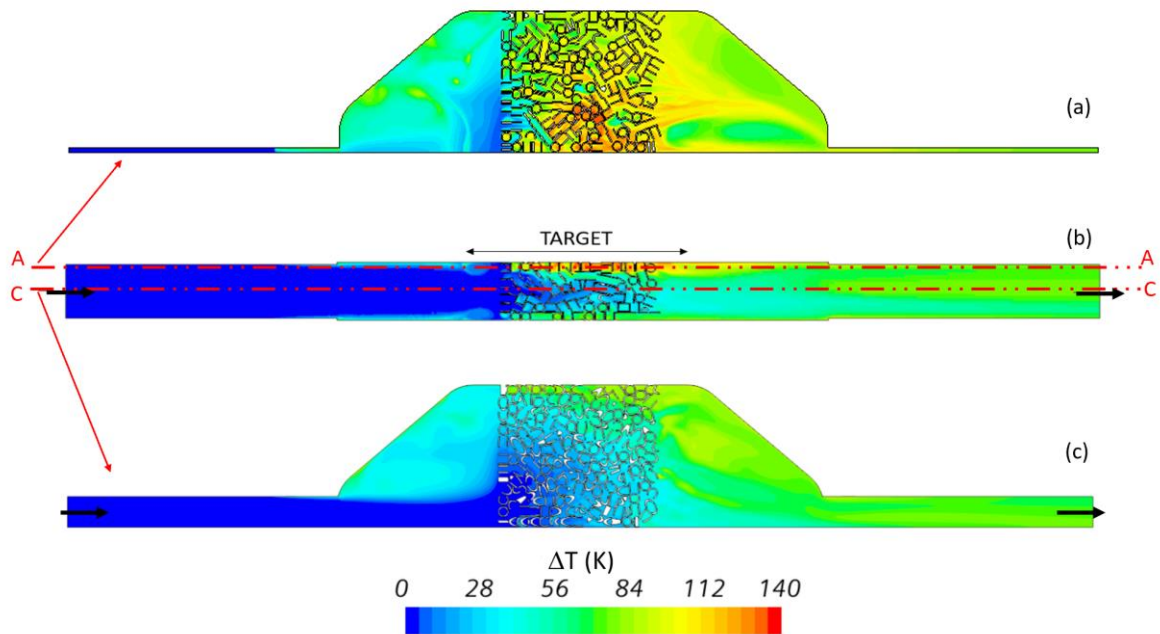

639

640

641

642

643

644

645

646

647

648

649

650

651

652

653

654

655

Figure 21 - Computed field of the air temperature increase with respect to the ambient value on different surfaces for the case at 300 NI/min and 500 kW/m². (a) longitudinal surface (y-z plane) at 3 mm from the target heated surface ,corresponding to the dashed line “AA” in (b); (b) transverse surface (x-z plane) corresponding to the symmetry axis of the sample; (c) longitudinal surface (y-z plane) at 8.5 mm from the target heated surface ,corresponding to the dashed line “CC” in (b).

For the same test case of **Figure 20**, the computed temperature map for the air on different cross-sections of the mock-up is reported in **Figure 21**. From the two longitudinal sections (**Figure 21a,c**), taken at different depths below the heated surface, it is shown that already in the inlet manifold the air temperature starts to increase due to the parasitic conduction through the structure from the target region. The fresh air flow enters the middle of the RR region (**Figure 21b**), as a sort of jet from the inlet pipe, while the top (target region) and bottom sides of the mock-up experience a higher coolant temperature in view of the proximity to the wall, which is heated directly or indirectly (parasitic conduction). The longitudinal section closer to the target in **Figure 21a** keeps the memory of the location where the peak incident flux was experienced, while in the longitudinal section far from the target in **Figure 21c** it is shown that the air jet tends to keep the flow colder in the middle of the mock-

656 up. In both sections, a strong mixing occurs in the outlet manifold, driven by the vortices in the flow
657 field, see **Figure 14** and **Figure 15**.

658 The validation of the thermal aspects of the CFD simulation is first performed on the entire set
659 of TC measurements for one test at the high heat flux, and the results are reported in **Figure 22**,
660 showing an excellent agreement between the simulations and the experimental data, within the error-
661 bars. The definition of the right error bar is a crucial step in the validation process. The experimental
662 error bar, which was already shown in **Figure 8**, takes into account the ± 1.5 K intrinsic reading
663 uncertainty of the thermocouples (which were counted twice since it is a temperature difference
664 between two thermocouples) plus the standard deviation calculated from the two-minutes or more
665 “quasi-steady-state” period needed to validate the test. The computational error bar is less
666 straightforward. It accounts for both the input parameters and mesh independence uncertainties. The
667 input parameters error was considered by solving the thermohydraulic model in the two cases that
668 would have given the maximum and minimum temperature results: maximum heat flux with the
669 minimum flowrate and minimum heat flux with the maximum flowrate, respectively. Once these
670 two simulations were solved for each experimental case, the 0.5% uncertainty related to the mesh
671 independence study was also considered. The overall agreement on the entire set of thermocouples
672 is reasonable, although a large disagreement is found for TK06, at the inlet in the symmetry plane. At
673 the TK06 location, in fact, due to the randomness of the RR displacement in the DEM simulation,
674 there is by chance a poor contact between the RR matrix and the target, see also **Figure 20**, so that the
675 local comparison returns a large underestimation of the measured value. The agreement in the values
676 of TK09-TK03 is good: the computed value falls between the two measured values and it is
677 comparable to both them, within the error-bars. Considering, now, the three thermocouples
678 belonging to the central row, an excellent agreement is computed in the middle, close to the center of
679 the heat load; the agreement on TK02 is within the error bar, while the computed TK08 is largely
680 above the measured values. Note, however, that TK08 could be unreliable as it was not working
681 properly in many of the tests and it is largely below the measured value of TK02. As far as the two
682 sides thermocouples located further downstream below the target, the two measured values are in
683 good agreement and both above the computed one out of the error-bar. A lower computed value can
684 be again due to a local poor thermal contact between the heated target and the rings.

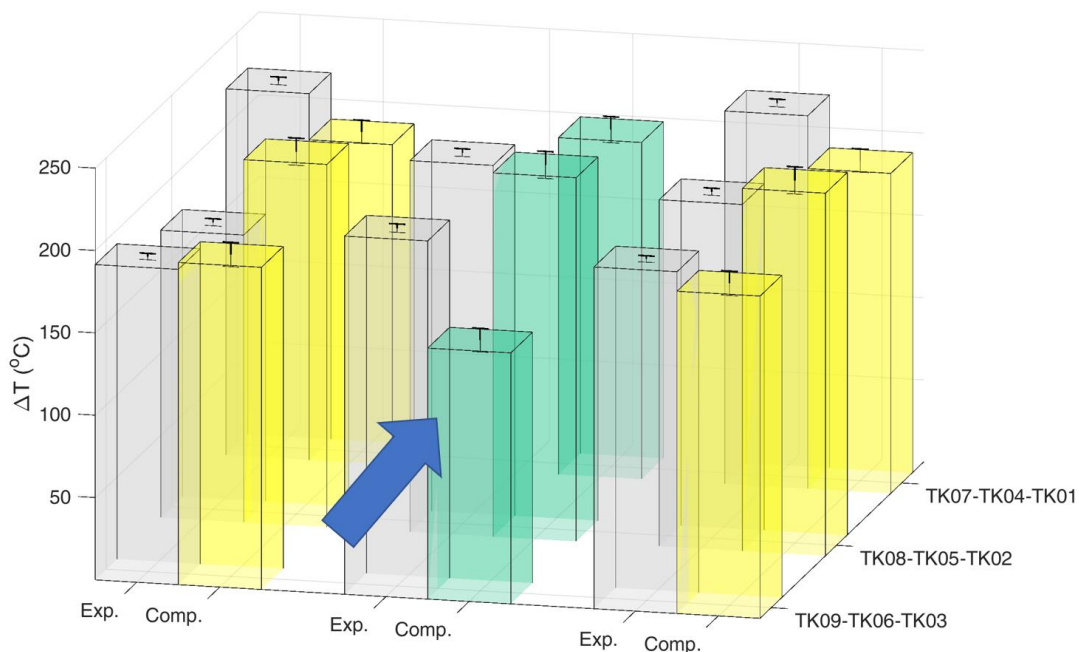

685

686 **Figure 22** - Comparison between experimental and computed results: case with 700 kW/m^2 and 300 l/min .

687

688 An extensive comparison with the CFD results, including the entire dataset, has been performed
 689 on the peak value TK05, as reported in **Figure 23**. A very good match is found between the computed
 690 and measured values, for all the cases under exams: flowrate 100-300 NI/min and peak heat flux 100-
 691 700 kW/m². The expected trend of temperature increase with the peak heat flux is retrieved, the
 692 steeper the slope the lower the mass flow rate is. A parametric analysis performed on the effective
 693 conductivity adopted for the RR region has been performed on the test case at the highest load, using
 694 the value of 2000 W/m/K, which was the minimum value quoted in (Bertinetti, 2019). The computed
 695 results, in that case, showed differences in the order of 0.1K, which can be considered negligible. The
 696 tests of the planar mockup with the available diagnostic do not provide useful information for fine
 697 tuning of the effective RR conductivity.
 698

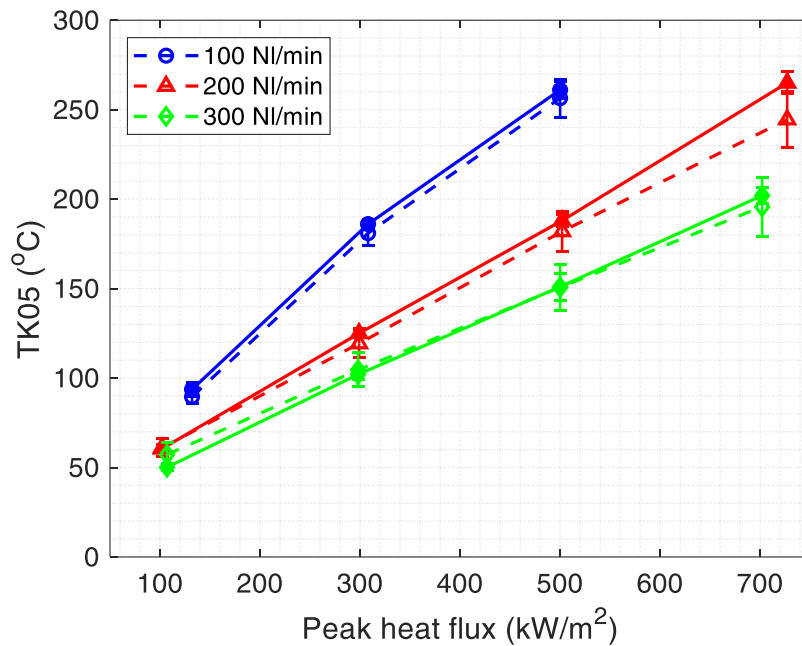

699
 700 **Figure 23** – Validation of TK05 temperature for different flowrates. Computed (solid symbols) vs measured
 701 (open symbols), with respective error-bars.

702
 703 A more detailed investigation of the computed results allowed assessing the hot-spot
 704 temperature on the heated surface of the target, reported in **Figure 24**, which could not be measured
 705 directly. It was checked that the tests were very far from the melting temperature of the target, i.e.
 706 1083°C (Davis and Smith, 1996), but also from the brazing temperature of the RR, which is 970°C and
 707 constitutes an upper bound temperature for the tests. Note that, while for the gyrotron mock-up the
 708 thermal stresses are a key issue in guaranteeing the device performance (Leggieri et al., 2020), here
 709 the thermo-mechanical constraints are relaxed, since the mock-up is free to expand in the horizontal
 710 direction, and just loosely bounded in the vertical direction. The overall picture of the hot-spot
 711 temperature is reported in **Figure 24**, showing that it didn't exceed 300 °C in any of the test conditions,
 712 with a maximum gradient of ~ 30 K across the target (hot-cold sides) in the most loaded case.

713 Note that in the 2019 experimental campaign a maximum temperature increase in the mock-up
 714 comparable to that already measured during previous tests in water purposely targeted – a second
 715 test campaign is planned for the summer 2021 in the framework of another SFERA III project in 2021
 716 (Sanchez, 2020), targeting much higher temperature values. Extrapolating the plotted trend at the
 717 highest flowrate, a maximum heat flux up to 3 times larger than the peak value already tested could
 718 be tolerated before reaching the temperature upper bound– this information will be useful in the
 719 forthcoming re-tests of the mock-up. Looking at the surface temperature maps in the insets in **Figure**
 720 **24**, it is confirmed that the hot spot does not occur in the center of the target, but slightly downstream,
 721 with a clear cooling effect of the fluid along its flow direction.

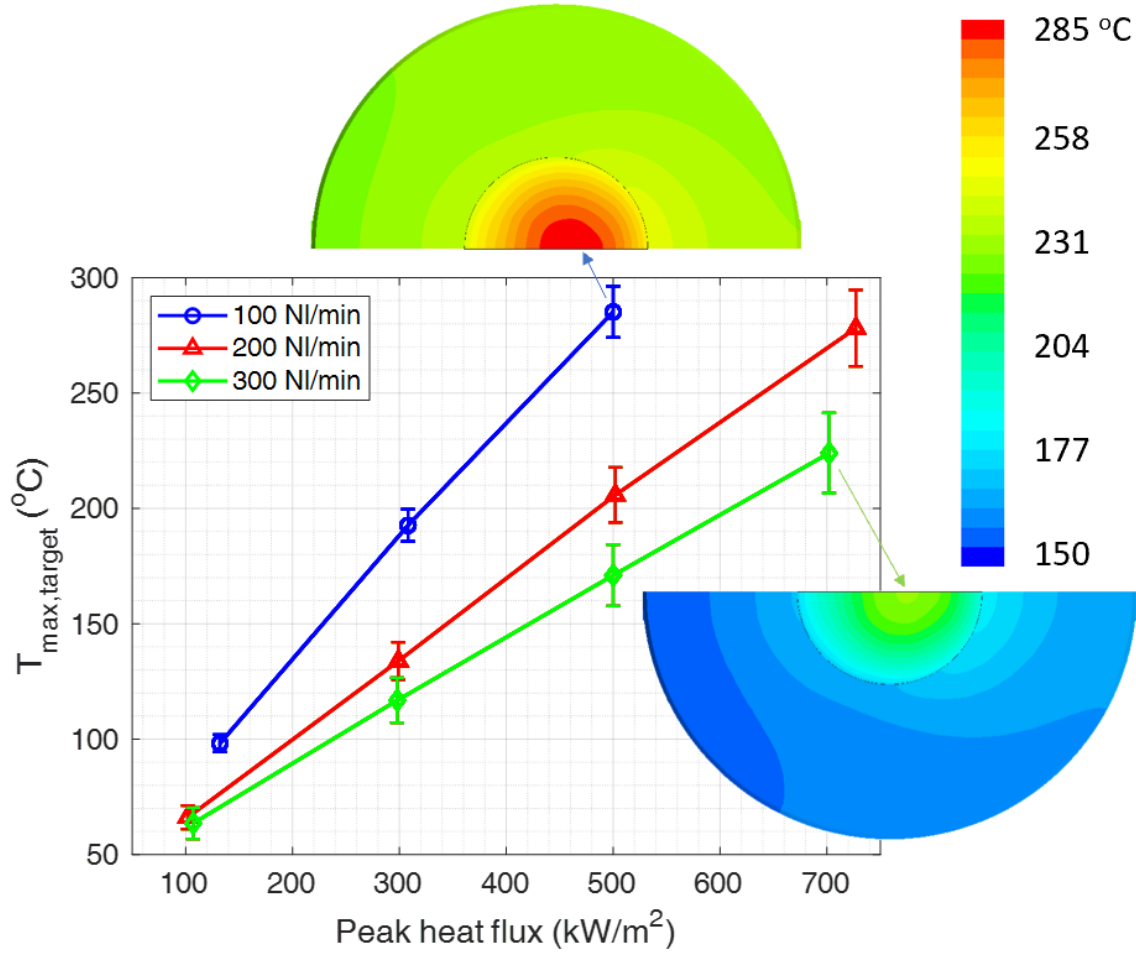

722

723

Figure 24 – Computed hot spot temperature on the target as a function of the heat load, for different flow rates.

724

In the insets, the temperature map computed on the heated target and surrounding envelop is also reported

725

for the two cases at 100 NI/min, 500 kW/m² and 300 NI/min, 700 kW/m², respectively.

726

727

From the computed results, restricting the analysis to the region of the RR, a local heat transfer coefficient HTC, and then local and average pseudo-dimensionless Nusselt number Nu^* could be derived from the definition reported in Eqs. 7-9, respectively:

728

731

$$HTC(z) = \frac{\overline{Q_{wall}(z)}}{(T_{wall}(z) - T_{bulk}(z))} \quad (7)$$

732

$$Nu^*(z) = \frac{HTC(z)}{k_f(z)} \quad (8)$$

733

$$\overline{Nu^*} = \int_0^L Nu^*(z) dz = \int_0^L \frac{\overline{Q_{wall}(z)}}{k_f(z) \times (T_{wall}(z) - T_{bulk}(z))} dz \quad (9)$$

734

735

where $Q_{wall}(z)$ is the azimuthally averaged wall heat flux transferred from the wall to the fluid at the axial coordinate z , $T_{wall}(z)$ is the azimuthally averaged wall temperature at the axial coordinate z , $T_{bulk}(z)$ is the bulk air temperature at the axial coordinate z , k_f is the air conductivity, evaluated at the local average wall temperature of the coolant. The resulting HTC ranges from 160 to 400 W/m²/K, depending on the volume flowrate, once the heat flux has been fixed to 500 kW/m², showing a huge enhancement in the heat transfer.

741

The Performance Evaluation Criteria (PEC) (Wongcharee et al., 2011) can be introduced to summarize the results and to weight the two main phenomena associated to the presence of random

742

743 packed beds of RRs: the increase of the heat transfer coefficient and the associated increase of pressure
 744 drop (which determines a higher pumping cost). The PEC can be defined as follows:
 745

$$746 \quad PEC = \frac{\overline{Nu}^* / \overline{Nu}_c^*}{(f^* / f_c^*)^{1/3}} \quad (Eq. 10)$$

747
 748 Where, the subscript “c” represents clear receiver tube without porous medium and f^* is a pseudo-
 749 dimensionless friction factor evaluated through the Darcy relation (Eq. 11):
 750

$$751 \quad f^* = 2 \frac{\Delta p}{\rho \bar{v}^2} \quad (Eq. 11)$$

752
 753 In Eq.(11), Δp is the computed pressure drop along the mock-up w/o the RRs, \bar{v} is the average fluid
 754 velocity between inlet outlet sections and ρ is the fluid density evaluated at the average bulk
 755 temperature along the tube. The values of the PEC as a function of the Re number are reported in
 756 **Figure 25**, showing that, when the flowrate increase, the weight of the pressure drop becomes more
 757 and more evident. The advantage of the insert of the RRs packed bed is, however, achieved for all the
 758 cases, with a PEC between 2 and 2.5. An increase of 50%, on average, is obtained with respect to the
 759 porous media configurations studied in (Zheng et al, 2017).
 760

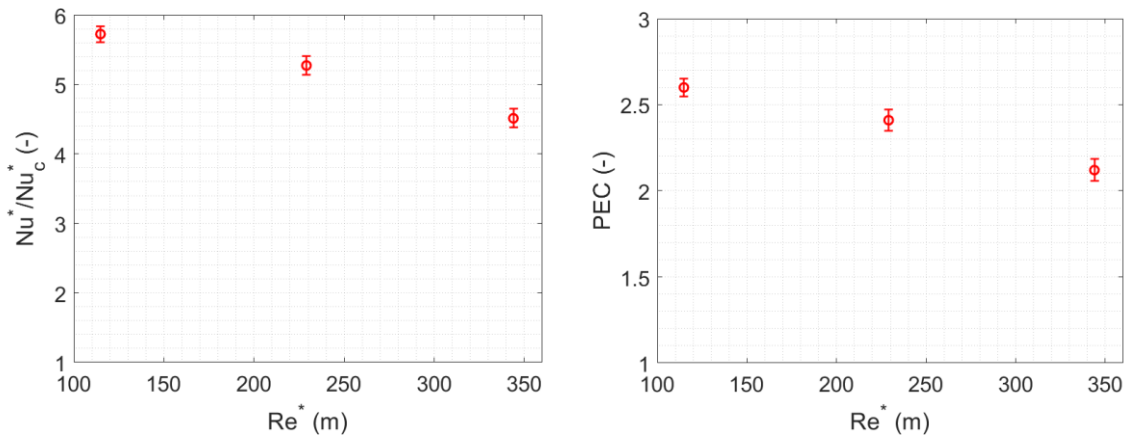

761 (a) (b)

762 **Figure 25** – (a) Ratio between the computed average Nu^* for the mock-up with RRs and for the clear
 763 configuration at 500 kW/m^2 , as a function of Re^* ; (b) Computed PEC at 500 kW/m^2 as a function of Re^* .
 764

765 5. Conclusions and Perspectives

766 A porous receiver, constituted by a rectangular-shaped channel equipped with a Raschig Rings
 767 block below the heated side, has been tested for the first time in the solar field, in the furnace SF60 at
 768 the PSA, targeting a possible application for Central Towers. The receiver was a planar mock-up of a
 769 gyrotron cavity used in nuclear fusion applications, for which the removal of high heat fluxes on a
 770 small surface is also a crucial issue. While in the nuclear applications the cooling fluid which flows
 771 through the porous matrix is subcooled water, the PSA tests were carried out using ambient air as
 772 the operating fluid.

773 The tests allowed measuring the hydraulic characteristic of the sample and its thermal response
 774 when subject to different heat load levels and cooled by different air flowrates.

775 The development of a suitable numerical thermal-hydraulic model, based on the DEM technique
 776 as far as the RRs generation is concerned, allowed, after a comprehensive validation against the
 777 measured hydraulic and thermal-hydraulic data, to analyze the test results. The radiative and
 778 convective losses turned out to be $\sim 10\%$ of the incident power. The maximum temperature reached

779 on the heater target stayed in all cases below 300 °C in the 2019 test campaign, with a maximum
780 difference of 30 K across the target. That leaves space to increase significantly the heat load in the
781 future tests, planned at the PSA in July 2021, to check the actual operating limits of such a target.

782 The numerical model allowed also to quantify the effectiveness of introducing the porous matrix
783 below the heated target, with respect to a plane rectangular channel. The figures of merit of the
784 receiver equipped with RR are very encouraging for the future further development of tubular
785 receivers with that porous matrix. An enhancement in the Nu number of ~ 5 was in fact computed,
786 together with a Performance Evaluation Criteria, combining heat transfer enhancement and pressure
787 drop increase, larger than 2 for all flow rates.

788 In perspective, from the experimental point of view, a retest the receiver at the PSA is planned
789 for 2021 at large heat loads, to fully explore the operation limits of the sample configuration, targeting
790 an upper value of ~950 °C on the heated surface. From the numerical point of view, with the validated
791 model, we plan to perform a detailed analysis for a tubular receiver equipped with RRs, to check if
792 the enhanced performance of the sample presented here holds for a tubular sample. Also, the optimal
793 dimension of RR will be addressed parametrically both experimentally and numerically, together
794 with a partial filling of the tubes, to identify the best configuration for a high-efficiency air receiver.
795

796 **Acknowledgements:**

797 The tests have been financed by the European Union's Horizon 2020 research and innovation
798 program: Solar Facilities for the European Research Area – Third Phase (SFERA III) under grant
799 agreement N. 823802. We thank Dr. M. Cagnoli, Dr. R. Bonifetto and Prof. R. Zanino for preliminary
800 discussion on the test campaign. We also thank Dr. A. Leggieri for the careful check that no
801 confidential data owned by THALES, were reported in the paper, and for giving access to the mock-
802 up experimental data collected in previous test campaigns.

803 We acknowledge the use of the computational resources provided by hpc@polito, which is a project of Academic
804 Computing within the Department of Control and Computer Engineering at the Politecnico di Torino
805 (<http://hpc.polito.it>).

806 **Abbreviations**

CFD	Computational Fluid Dynamics
CIEMAT	Centro de Investigaciones Energéticas, Medioambientales y Tecnológicas
CSP	Concentrating Solar Power
DEM	Discrete Element Method
DNI	Direct Normal Irradiance
ERT	Enhanced Receiver Tube
GCI	Grid Convergence Index
MMC	Metal Matrix Composite
HiTRec	High Temperature Receiver
PEC	Performance Evaluation Criteria
PSA	Plataforma Solar de Almería
RANS	Reynolds-averaged Navier–Stokes
RBD	Rigid Body Dynamics
RRs	Raschig Rings
SF	Solar Furnace
SFERA	Solar Facilities for the European Research Area
SST	Shear Stress Transport
TC	Thermocouple

807

808 **Greek symbols**

α	absorptivity
Δp	pressure drop (Pa)
∇p	pressure gradient (Pa/m)
ΔT	temperature difference (K)
ε	emissivity
κ	turbulent kinetic energy (m ² /s ²)
μ	dynamic viscosity (Pa·s)
ρ	density (kg/m ³)
Φ	applied heat flux (W/m ²)
ω	specific dissipation rate of the turbulent kinetic energy (s ⁻¹)

809

810 Symbols

c_F	Dimensionless form-drag constant
D	diameter (m)
DI*	normalized base size of the grid cells
f	friction factor
f*	Pseudo-dimensionless friction factor
H	height (m)
HTC	heat Transfer Coefficient (W/m ² /K)
k	thermal conductivity (W/m/K)
K	porous media permeability (m ²)
L	length (m)
\dot{m}	mass flowrate (kg/s)
Ncells	number of cells
NI	Normal litre (normal conditions T = 0 °C and p = 1 bar)
Nu	Nusselt number
Nu*	Pseudo-dimensionless Nusselt number
p	pressure (Pa)
Pr	Prandtl number
Q	heat flux exchanged between interfaces (W/m ²)
Ra	Rayleigh number
Re	Reynolds number
Re*	Pseudo-dimensionless Reynolds number
s	standard deviation
T	temperature (K)
v	velocity (m/s)
x, y, z	coordinate system

811

812 Subscripts

bulk	bulk
c	clear receiver
f	fluid
in	inlet
in-out	difference between inlet and outlet
out	outlet
p	pellet
peak	peak
wall	wall

813

814 **References**

815

816 Alkam, M.K., Al-Nimr, M., 1997. Unsteady non-darcian forced convection analysis in an annulus partially filled
817 with a porous material. *Journal of Heat Transfer*, vol. 119, no. 799-804.

818 Alkam, M.K., Al-Nimr M.A., 1999. Improving the performance of double-pipe heat exchangers by using porous
819 substrates. *International Journal of Heat and Mass Transfer*, vol. 42, no. 3609-3618.

820 Allio, A., Difonzo, R., Leggieri, A., Legrand, F., Marchesin, R., and Savoldi, L., 2020. Test and Modeling of the
821 Hydraulic Performance of High-Efficiency Cooling Configurations for Gyrotron Resonance Cavities.
822 *Energies*, vol. 13, no. 1163.

823 Ballestrin, J; Ulmer, S.; Morales, A.; Barnes, A.; Langley, L; Rodriguez, M. "Systematic Error in the measurement
824 of ery high solar irradiance". *Solar Energy material and solar cells.*, vol. 80, no. 3, pp. 375-381, 2003.

825 Becker, M., Fend, T., Hoffschmidt, B., Pitz-Paal, R., Reutter, O., Stamatov, V., Trimis, D., 2006 Theoretical and
826 numerical investigation of flow stability in porous materials applied as volumetric solar receivers. *Solar
827 energy*, vol. 80(10), no. 1241-1248.

828 Bejan, A., 2013. *Convection Heat Transfer*, Fourth Edition, John Wiley & Sons, Inc., Hoboken, New Jersey.

829 Albajar, F., Cau, F., Leggieri, A., Legrand, F., Perial, E., Ritz, G., Savoldi, L., Zanino, R., Zappatore, A., 2018.
830 Design, test and analysis of a gyrotron cavity mock-up cooled using mini channels. *IEEE Transactions on
831 Plasma Science*.

832 Bertinetti, A., 2019. Development of the Multi-physiCs tool for the integrated simulation of the Cavity and its
833 application for the design of gyrotron cavities for thermonuclear applications. PhD thesis, Politecnico di
834 Torino.

835 Cagnoli, M., Savoldi L., Zanino, R.; Zaversky, F., 2017. Coupled optical and CFD parametric analysis of an open
836 volumetric air receiver of honeycomb type for central tower CSP plants. *Solar Energy*, vol. 155, 523-536.

837 Cantone, M., Cagnoli, M., Savoldi, L., 2020. One-side heating test and modeling of tubular receivers equipped
838 with turbulence promoters for solar tower applications. To appear in *Applied Energy*.

839 CD-adapco, 2018. *STAR CCM+ User Guide Version 13.02*.

840 CIEMAT, 2019, *Plataforma Solar de Almeria, Annual Report 2019*, available at
841 <https://www.psa.es/en/techrep/2019/AnnualReport2019.pdf> (last visited on July 2020).

842 Conroy, T., Collins, M.N., Grimes, R., 2019. A review of steady-state thermal and mechanical modelling on
843 tubular solar receivers. *Renewable and Sustainable Energy Reviews*, 119:109591.

844 Davis, P., Smith, J.V., 1996. *ITER material properties handbook*. J. Nucl. Mater.

845 Dong, Y., Sosna, B., Korup, O., Rosowski, F., Horn, R., 2017. Investigation of radial heat transfer in a fixed-bed
846 reactor: CFD simulations and profile measurements. *Chemical Engineering Journal* vol. 317, 204-214.

847 European Commission, 2011. *Final report - SOLHYCO (Solar-Hybrid Power and Cogeneration Plants)*,
848 Available online at <https://cordis.europa.eu/project/id/19830/reporting/it> (last visited in July 2020).

849 European Commission, 2019. *Strategic energy technologies information system: Concentrated solar power*.
850 Available online: <https://setis.ec.europa.eu/technologies/concentrated-solar-energy> (last visited in July
851 2020).

852 Ferziger J. H., Peric, M., 2002. *Computational Methods for Fluid Dynamics*, 4th edition, Springer.

853 Ho, Clifford K.C., Romano, D., Yellowhair, J., Siegel, N.; Savoldi, L, Zanino, R., 2017. Characterization of particle
854 flow in a free-falling solar particle receiver. *Journal of Solar Energy Engineering*, 139(2).

855 Hoffschmidt, B., Pitz-Paal R., Bohmer, R., Fend, T., Rietbrock, P., 1999. 200 kWth open volumetric air receiver
856 (HiTRec) of DLR reached 1000 °C average outlet temperature at PSA. *Journal of Physics*, IV France 9.

857 Hoffschmidt, B., Tellez, F.M., Valverde, A., Fernandez, J., Fernandez, V., 2003. Performance evaluation of the
858 200-kWth HiTRec-II open volumetric air receiver". *Journal of Solar Energy Engineering*, vol.125, 87-94.

859 Kumar, K. R., Reddy, K. S., 2009. Thermal analysis of solar parabolic trough with porous disc receiver. *Applied
860 Energy*, vol.86(9), 1804-1812.

861 Incropera, F. P., Dewitt, D. P., Bergman, T. L., Lavine, A. S., 2006. *Fundamentals of Heat and Mass Transfer*. John
862 Wiley & Sons Inc, New York.

863 Leggieri, A., Bariou, D., Hermann, V., Legrand, F., Lietaer, G., Albajar, F., Sanchez, F., Alberti, S., Hogge, J.-P.,
864 Allio, A., Difonzo, R., Savoldi, L., Bruschi, A., Bin, W., Chelis, I., Tigelis, I., Avramidis, K. A., Dammertz,
865 G., Gantenbein, G., Illy, S., Ionnidis, Z., Jelonnek, J., Jin, J., Pagonakis, I. Gr., Rzesnicki, T., Thumm, M., 2020.
866 Upgrade of the European ITER 170 GHz 1 MW CW Industrial Gyrotron (TH1509), In *Proceedings of 7th ITC
867 International Vacuum Electronics Workshop (IVEW)*, Bad Honnef.

868 Lim, S., Kang, Y., Lee, H., Shin, S., 2014. Design optimization of a tubular solar receiver with a porous medium.
869 Applied thermal engineering, vol.62(2), 566-572.

870 Malalasekera, W., Versteeg, H. K., 2007. An introduction to computational fluid dynamics. The finite volume
871 method, Harlow: Prentice Hall.

872 Marek, M., 2017. Numerical simulation of a gas flow in a real geometry of random packed bed of Raschig rings.
873 Chemical Engineering Science, vol. 161, 382-393.

874 Moghaddam, E. M., Foumeny, E. A., Stankiewicz, A. I., Padding, J. T., 2020. Hydrodynamics of narrow-tube
875 fixed bed reactors filled with Raschig rings. Chemical Engineering Science, vol. X, 5:100057.

876 Mohamad, A., 2003. Heat transfer enhancements in heat exchangers fitted with porous media part I: constant
877 wall temperature. International Journal of Thermal Sciences, vol. 42, 385-395.

878 Mohammadi, O., Pironneau, B., 1994. Analysis of the k-eps turbulence model. Wiley.

879 Mwesigye, A., Bello-Ochende, T., Meyer, J. P., 2014. Heat transfer and thermodynamic performance of a
880 parabolic trough receiver with centrally placed perforated plate inserts. Applied energy, vol.136, 989-1003.

881 Rizzo, E., Heller, R., Richard, L.S., Zanino, R., 2012. Analysis and performance assessment for a 68 kA HTS
882 current lead heat exchanger. IEEE transactions on applied superconductivity, vol.22(3).

883 Rizzo, E., Heller, R., Richard, L.S., Zanino, R., 2013. Computational thermal-fluid dynamics analysis of the
884 laminar flow regime in the meander flow geometry characterizing the heat exchanger used in high
885 temperature superconducting current leads. Fusion Engineering and Design, vol.88(11), 2749-2756.

886 Roldán, M. I., Monterreal, R., 2014. Heat flux and temperature prediction on a volumetric receiver installed in a
887 solar furnace. Applied energy, vol. 120, 65–67.

888 Rozier, Y., 2015. Report on thermal cavity mock-up experiments, Thales Electron Device, Contract ref: F4E-OPE-
889 447, deliverable D3. Available upon request.

890 Sanchez, R., May 2020. Private communication.

891 Savoldi, L., Albajar, F., Alberti, S., Avramidis, B.A., Bertinetti, A., Cau, F., Cimoni, F., Gantenbein, G., Hogge,
892 J.P., Ioannidis, Z.C., 2018. Assessment and optimization of the cavity thermal performance for the European
893 continuous wave gyrotrons. In Proceedings of the 27th IAEA Fusion Energy Conference (FEC 2018),
894 Gandhinagar, Indien, 22–27.

895 Sella, A., Raschig's Rings, vol. 5, Chemistry World, 2008.

896 Skocypec, R.D., Boehm, R.F., Chavez, J.M., 1989. Heat transfer modeling of the IEA/SSPS volumetric receiver. J.
897 Sol. Energy Eng., vol. 111, 138-143.

898 Toolbox, 2003. Available online: https://www.engineeringtoolbox.com/emissivity-coefficients-d_447.html. (last
899 visited in July 2020).

900 Toolbox, 2009. Available online: [https://www.engineeringtoolbox.com/solar-radiation-absorbed-materials-
901 d_1568.html](https://www.engineeringtoolbox.com/solar-radiation-absorbed-materials-d_1568.html) (last visited in July 2020).

902 Uhlig, R., Gobereit, B., Rheinländer, J., 2015. Advancing tube receiver performance by using corrugated tubes.
903 Energy Procedia; vol. 69, 563-572.

904 Wongcharee K., Changcharoen W., Eiamsa-Ard S., 2011. Numerical investigation of flow friction and heat
905 transfer in a channel with various shaped ribs mounted on two opposite ribbed walls. International Journal
906 of Chemical Reactor Engineering, vol. 9(1).

907 Wu, Z., Caliot, C., Bai, F., Flamant, G., Wang, Z., Zhang, J., Tian, C., 2010. Experimental and numerical studies of
908 the pressure drop in ceramic foams for volumetric solar receiver applications. Applied Energy, vol. 87(2),
909 504-513.

910 Yang, M., Yang, X., Yang, X., Ding, J., 2010. Heat transfer enhancement and performance of the molten salt
911 receiver of a solar power tower. Applied Energy, vol. 87(9), 2808-2811.

912 Zanino, R., Romano, C.K., Savoldi, L., 2016. Preliminary discrete element modeling of a falling particle curtain
913 for CSP central tower receivers. In AIP Conference Proceedings, vol. 1734. No. 1. AIP Publishing LLC.

914 Zheng, Z.J., Li, M.J., He, Y.L., 2017. Thermal analysis of solar central receiver tube with porous inserts and non-
915 uniform heat flux. Applied Energy, vol.185, 1152-1161.

916 Zhu, Q., Xuan, Y., 2018. Performance analysis of a volumetric receiver composed of packed shaped particles with
917 spectrally dependent emissivity. International Journal of Heat and Mass Transfer, vol.122, 421-431.

918

919