

The N2-dominated scenario of leptogenesis

Original

The N2-dominated scenario of leptogenesis / Fiorentin, M.R.. - In: POS PROCEEDINGS OF SCIENCE. - ISSN 1824-8039. - ELETTRONICO. - (2014). (2014 Corfu Summer Institute "School and Workshops on Elementary Particle Physics and Gravity").

Availability:

This version is available at: 11583/2974227 since: 2022-12-29T15:02:05Z

Publisher:

Proceedings of Science (PoS)

Published

DOI:

Terms of use:

This article is made available under terms and conditions as specified in the corresponding bibliographic description in the repository

Publisher copyright

(Article begins on next page)

Third conference of the
International Network for
Didactic Research in University Mathematics

INDRUM 2020
September
12-19

Cyberspace-Virtually from Bizerte

TUNISIA

PROCEEDINGS

<http://indrum2020.sciencesconf.org/>

INDRUM 2020 is an ERME topic conference

erme
european society for research in mathematics education



INDRUM2020 PROCEEDINGS

Third conference of the International Network for Didactic Research in University Mathematics

12-19 Sep 2020

Cyberspace (virtually from Bizerte)

Tunisia

Editors: Thomas Hausberger, Marianna Bosch and Faiza Chellougui
Publisher: University of Carthage and INDRUM
Place: Bizerte, Tunisia
Year: 2020
ISSN: 2496-1027 (online)

Sponsors:

INDRUM2020 was initially to be held March 27-29 in Bizerte, Tunisia, with the support of the Faculty of Sciences of Bizerte, University of Carthage. Due to the covid-19 worldwide event, it was postponed to September 12-19 and held in the form of an online conference, virtually from Bizerte, with the support avec the IMAG, University of Montpellier.



INDRUM2020 was an ERME Topic Conference.

ERME Topic Conferences (ETC) are conferences organised on a specific research theme or themes related to the work of ERME as presented in associated working groups at CERME conferences. Their aim is to extend the work of the group or groups in specific directions with clear value to the mathematics education research community.

<http://www.mathematik.uni-dortmund.de/~erme/>



Table of contents

INDRUM2020 Editorial	1
Plenary talk	7
Professional and academic bases of university mathematics teaching for the 21st century: the anthropological approach to practice based research, Winsløw Carl .	8
Panel	28
Tertiary education in the digital age, Fleischmann Yael [et al.]	29
TWG1: Calculus and Analysis	47
Report of the TWG1: Calculus and analysis, Branchetti Laura [et al.]	48
Conceptions de l'intégrale de Riemann des étudiants à l'entrée en classes préparatoires, Akrouti Inen	53
Nature et origine des difficultés des étudiants lors de l'utilisation des approximations locales des fonctions en début de l'université : Cas des classes préparatoires aux études d'ingénieurs, Belhaj Amor Fatma	63
Continuity of real functions in high school: a teaching sequence based on limits and topology, Branchetti Laura [et al.]	73
Suites définies par récurrence dans la transition lycée-université : activité et travail mathématique, Flores González Macarena [et al.]	83
Gesture and diagram production as tools for identifying the key idea in topology proving tasks, Gallagher Keith [et al.]	93
Intuitive mathematical discourse about the complex path integral, Hanke Erik .	103

Exploring Learning Potentials of Advanced Mathematics, Hochmuth Reinhard	113
Analyse discursive de l’enseignement des fonctions trigonométriques dans la transition lycée/université, Khalloufi-Mouha Faten	123
”I only know the absolute value function” – About students’ concept images and example spaces concerning continuity and differentiability, Lankeit Elisa [et al.]	133
Review of our work on the teaching and learning of functions of two variables, Martínez-Planell Rafael [et al.]	143
Un problème de CAPES comme premier pas vers une implémentation du plan B de Klein pour l’intégrale, Planchon Gaëtan [et al.]	153

TWG2: Mathematics for engineers; Mathematical Modelling; Mathematics and other disciplines **163**

TWG2 report: Mathematics for engineers, Mathematical Modelling, Mathematics and other disciplines, Barquero Berta [et al.]	164
How to integrate study and research paths into university courses? Teaching formats and ecologies, Bosch Marianna [et al.]	169
Pratiques in situ d’enseignants universitaires et confrontation avec le vécu des étudiants : une étude de cas, Bridoux Stéphanie [et al.]	179
Architectural Heritage between Mathematics and Representation: studying the geometry of a barrel vault with lunettes at a first year Bachelor’s in Architecture, Cumino Caterina [et al.]	189
Mathematical modelling in probability at the secondary-tertiary transition, example of biological sciences students at university, Doukhan Camille	199
Analysing mathematical and didactic praxeologies in an engineering course: the case of Strength of Materials., Gonzalez-Martin Alejandro [et al.]	209
The professional identity of teacher-researchers in mathematics, Grenier-Boley Nicolas [et al.]	219
How applicationism impact modelling in a Belgian school of economy and the viability of an alternative epistemology, Job Pierre	229
The Role of Learning Strategies for Performance in Mathematics Courses for Engineers, Liebendörfer Michael [et al.]	238

First-year university students making sense of symbols in integration, Nilsen Hans Kristian	248
Exploring undergraduate engineering students' competencies and attitudes towards mathematical problem-posing in integral calculus, Radmehr Farzad [et al.]	258
Impact of attitude on approaches to learning mathematics: a structural equation modeling approach, Zakariya Yusuf F. [et al.]	268
Car Race - an interdisciplinary Calculus' project using Python, Gaspar Martins Sandra	278
Bridging the gap between mathematics courses and mathematics in the workplace: the example of a study and research path for future engineers, Quéré Pierre-Vincent	280
TWG3: Number Theory, Algebra, Discrete Mathematics, Logic	282
University Mathematics Didactic Research on Number Theory, Algebra, Discrete Mathematics, Logic, Biehler Rolf [et al.]	283
Analyse des effets d'un dispositif innovant sur l'évolution des représentations des étudiants en première année de licence de mathématiques, Bloch Isabelle [et al.] .	288
On students' reasoning about span in the context of Inquiry-Oriented Instruction, Bouhjar Khalid [et al.]	298
Etude de l'enseignement du concept d'idéal dans les premières années post-secondaires : élaboration de modèles praxéologiques de référence, Candy Julie	308
Backward reasoning and epistemic actions in strategic games problems, Gómez-Chacón Inés M [et al.]	318
Introducing group theory with its raison d'être for students, Hamanaka Hiroaki [et al.]	328
Designing a Geometry Capstone Course for Student Teachers: Bridging the gap between academic mathematics and school mathematics in the case of congruence, Hoffmann Max [et al.]	338
Relation between understandings of linear algebra concepts in the embodied world and in the symbolic world, Kawazoe Mitsuru	348
Investigating high school graduates' personal meaning of the notion of "mathematical proof", Kempen Leander [et al.]	358

Récurrence et récursivité: analyses de preuves de chercheurs dans une perspective didactique à l'interface mathématiques-informatique, Leon Nicolas [et al.]	368
Utilisation de l'articulation entre les points de vue syntaxique et sémantique dans l'analyse d'un cours sur le raisonnement, Mesnil Zoé [et al.]	378
Process conception of linear transformation from a functional perspective, Villabona Diana [et al.]	388

TWG4: Students' and teachers' practices 397

TWG4: Students' and teachers' practices: Group report, Biza Irene [et al.]	398
From Mathematics to Mathematics Education: triggering and assessing mathematics students' mathematical and pedagogical discourses, Biza Irene [et al.]	403
From an analysis of content to an analysis of ordinary lecturing practices: A case-study in mathematical analysis., Chorlay Renaud [et al.]	413
Design and evaluation of digital innovations for an attendance-based bridging course in mathematics, Fleischmann Yael [et al.]	423
Méthode pour l'engagement du professeur du lycée dans la transition vers l'université, Ghedamsi Imène [et al.]	433
Programming as an artefact: what do we learn about university students' activity?, Gueudet Ghislaine [et al.]	443
Exploring the affordances of Numbas for mathematical learning: a case study, Hadjerrouit Said	453
Learning collaboratively with digital instructional media: Students' communicational behaviour and its influence on learning outcome, Heinrich Daniel C. [et al.]	463
Proof Teaching at the University Level: the case of a lecturer who is mathematician and mathematics educator, Karavi Thomais [et al.]	473
Course Coordinator Orientations Toward their Work, Martinez Antonio [et al.]	483
The step from tertiary to secondary education in mathematics. In search of a shared paradigm, Nicolas Pedro [et al.]	493
The relation between mathematics research activity and the design of resources for teaching at the university, Sabra Hussein	503

A Student's Complex Structure of Schemes Development for Authentic Programming-Based Mathematical Investigation Projects, Buteau Chantal [et al.]	513
Promoting mathematics teacher reflection in online graduate problem solving course through peer feedback and portfolios, Glassmeyer David	515
A novel application of the instrumental approach in research on mathematical tasks, Toppol Vegard	517

Author Index	519
---------------------	------------

Architectural Heritage between Mathematics and Representation: studying the geometry of a barrel vault with lunettes at a first year Bachelor's in Architecture

Caterina Cumino¹, Martino Pavignano², and Ursula Zich²

¹Politecnico di Torino, Department of Mathematical Sciences “G. L. Lagrange”, Italy, caterina.cumino@polito.it; ²Politecnico di Torino, Department of Architecture and Design, Italy, martino.pavignano@polito.it, ursula.zich@polito.it.

We present an interdisciplinary activity, directed to students of the first year Bachelor's in Architecture, about the visualization of mathematical objects through physical and digital models, with specific regard to surfaces generated by intersections of cylinders. We focus on the geometrical structure of barrel vaults with lunettes and propose the use of various kind of models to improve the accessibility of interdisciplinary elements and to translate specialistic knowledge, building a common language for students with different backgrounds. The work is a result of a broader research project, dedicated to enhancing the relationship between Mathematics and Architecture through Geometry and Representation.

Keywords: Geometry for Architects, Surfaces, Models, Representation, Visualization.

INTRODUCTION

In the field of Italian university Mathematics education, the need to set up a dialogue within other disciplines in which Mathematics is taught (Architecture, Engineering, Biology, etc.) is increasingly felt. Teaching Mathematics to non-Mathematics learners means teaching it as a service subject, hence as a tool to model systems of the domain and to solve the associated problems (Howson, Kahane, Lauginie & Tuckheim 1988).

We are interested in the role played by Mathematics in courses of the bachelor's degree program in Architecture. In this context, basic mathematical tools are conveyed by the first year Calculus course: here students learn topics which are preparatory and in support of the parallel course of Architectural Drawing and Survey Laboratory (and of the subsequent courses of building physics, real estate evaluation, as well as of the structural matters).

TEACHING PROBLEMS

One of the main teaching problems is that students, in their first year of academic study, come from diversified educational backgrounds and have different skills (or lack of them) about mathematical and graphic language; as for Mathematics, they may not understand where and when the proposed abstract mathematical topics will be concretely applied. It should be necessary to create a perception of their use value in the wider sense, in order to avoid the traditional insularity of Maths in the technical faculties (see e.g. Harris, Black, Hernandez-Martinez, Pepin, Williams, & TransMaths Team 2015; or Rasmussen, Marrongelle, & Borba 2014) and to promote a synergistic relationship that fills the gaps between the various languages. For example, the

increased relevance of digital and parametric modelling in Architecture (see e.g. Calvano 2019) has created a need for developing the education of future architects through a greater integration of mathematics and disciplines which are specific of Architecture. Another problem is students' previous mathematical experience in facing university studies, depending on whether they were more or less oriented to the formation of spatial visualization capacity. Important difficulties appear in the transition from 2D to 3D analytical representations of geometrical objects (Cumino, Pavignano, Spreafico, & Zich 2019): for example, from the 2D analytical representation of a straight line or, more generally, of a plane curve to the representation of a plane or cylinder having that curve as a directrix. Students have the concept of cartesian equation based on their experience from high school Mathematics, but some of them may not accept that the same equation represents different set of points passing from 2D to 3D. Such phenomena can be related to those of «tacit models» mentioned by Fischbein (1989), who refers to representations of certain mathematical, abstract notions developed at an initial stage of the learning process which continue to influence, tacitly, reasoning and interpretations of the learner, hence the need to help students to control the (possibly negative) impact of these models.

So, a myriad of problems of cognitive nature (type of background, crystallized information, gaps between disciplinary languages) or of didactic nature (teaching strategies, disciplinary content and courses organization) are to be taken in consideration, before being able to concretize any proposal for teaching interventions.

Investigations in this direction, related to this particular context, seem to have been somewhat limited, mainly in connection with other disciplines, while correlations between spatial imagery information processing, spatial visualization and geometrical figure apprehension have been the subject of a number of studies, see e.g. the comprehensive review by Jones and Tzekaki (2016) and Kovačević, N. (2017), about recent research in Geometry education. On the other hand, it is fundamental to overcome the aforementioned problems, not only from the point of view of basic mathematical education: when approaching the study of the built form, the architecture student should acquire interdisciplinary knowledge -thus developing basic skills- for its analysis and it is important to underline how the knowledge that 'flows' into an architectural design is not only related to its specific disciplines but includes a variety of methodologies and interpretations derived from other subjects. Therefore, in students' educational path, it seems worthwhile to set up study activities having an interdisciplinary approach.

In this contribution, we present an attempt in this direction, focusing on the Geometry education of architecture students and its role in connection to geometrical comprehension of architectural shapes and spatial visualization ability and we highlight the importance of mathematical thinking in the formalization of architectural structures, in particular of roofing systems constituted by vaults.

We also refer to Duval's analysis of visualization process and its interactions with geometrical reasoning, adapting it to the particular educational context; in this sense

we follow the idea of construction as a process dependent only on the connections between mathematical properties and technical constraints of the used tools.

VAULTS AND GEOMETRY

Most of the Italian Architectural Heritage was built with masonry structures and vaults are roofing elements mainly used for covering rooms of a building. Original vaults were as simple as the surfaces of rotation and/or of translation that were used to design them. Then they became more complex systems, reaching different forms (subtended by as many geometries).

In Architecture, the use of Geometry and its elements, such as points, lines, planes, then surfaces and solids [1], as the result of a learning path has its roots in the ancient past; i.e. Leon Battista Alberti, Francesco di Giorgio Martini, Andrea Palladio, Vincenzo Scamozzi and Guarino Guarini wrote about these issues in their treatises (Spallone-Vitali 2017, pp. 88-90), see Figure 1. The variety of the vaults compositions is briefly exemplified in Figure 2a, b.

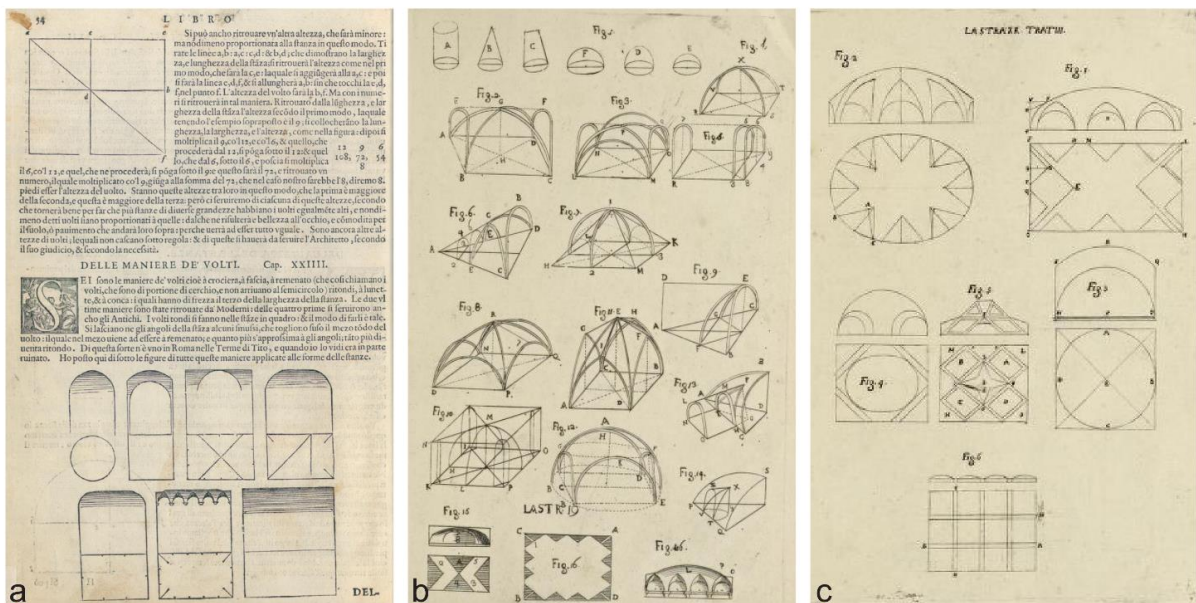

Figure 1: Historical examples of geometric and graphic description of some vaults. Palladio 1570, p. 54; b) Guarini 1737, tav. XXVII, c) Guarini 1737, tav. XXVIII.

The study of these constructive elements plays an important role: we should provide students with some critical tools useful for the conceptual investigation of these structures, even for starting from their graphic formalization.

During the 17th century Guarino Guarini, architect and mathematician, in his treatise, *Architettura Civile*, states that: «vaults [...] are hardest to be invented, to put in drawing and to build» (Guarini 1737, p. 183). Again, Guarini states that: «in each of its operations Architecture uses measures, then it relays on Geometry and deserves to know at least its fundamentals» (Guarini 1737, p. 3). His ideas clearly highlight the close relationship between geometry and the architectural artefact.

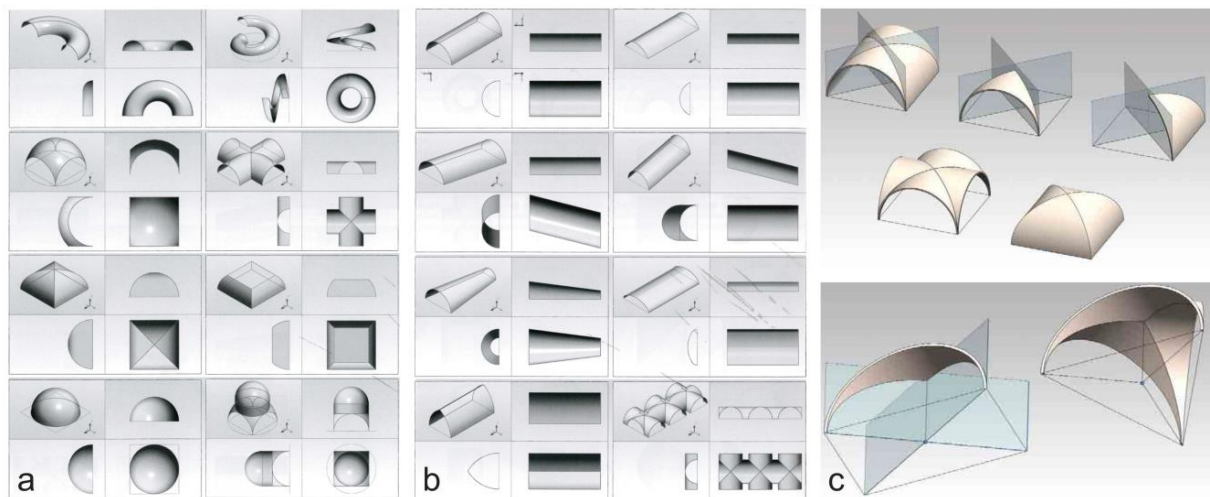

Figure 2: simple and compound vaulted systems: a), b) Bertocci, Bini 2012, pp. 265, 266; c) Fallavollita 2009, pp. 453, 455.

For example, Guarini sometimes used to describe the composition of a vaulted system by junction of parts of different surfaces cut by the same plane (Spallone-Vitali 2017). This idea is still used today. Figure 2c shows this kind of construction applied to square based groin and cloister vaults and to triangle-based groin vault, without caring about the problem of intersections. Recent bibliographical references for the geometric-conceptual study of vaults offer an almost always 3D or pseudo-3D set of views, with textual descriptions. Many authors represent these elements with axonometric views (see e.g. Docci, Gaiani, Maestri 2011; Fallavollita 2009) which immediately convey the idea of the three-dimensionality of these elements, but often neglect its geometrical genesis.

METHODOLOGY TO STUDY A BARREL VAULT WITH LUNETTES

In light of previous considerations, the complexity of the form needs a discretization of its characteristic and descriptive elements through the graphic language that, in being an expression of synthesis, risks to become an excessive simplification of its features. Consequently, at the base of the training path of the architectural student, there is the study conducted between the representation of a theoretical model and its analytical description.

We propose four teaching tools to enhance students' critical shape-reading skills referring to architectural heritage: a tangible model to introduce the problem; a graphic representation to investigate the relationship between drawing and shapes; a virtual model obtained by a dynamic geometric software (DGS), constructed through an analytical description; a physical model as outcome of the preceding three steps. These tools are in order to promote students' ability in switching between different registers of representation (see Duval 1999).

We identified a family of composite vaults -which can be traced back to intersections of barrel vaults with coplanar and orthogonal axes, see Figure 3- as having an explicit formative value in this context.

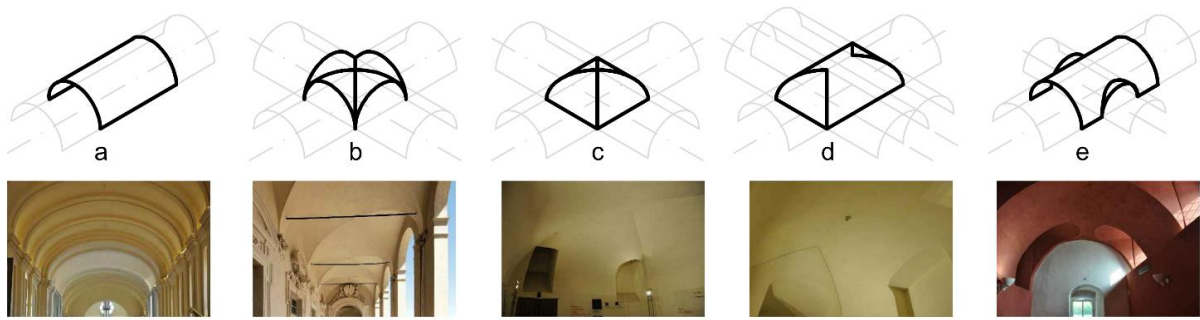

Figure 3: Cylinders intersections. a) barrel vault; b) groin vault; c) cloister vault; d) barrel vault with cloister heads; e) barrel vault with lunettes. Pictures of Royal Residence of Venaria Reale (Torino).

Graphic Analysis

Figure 4 shows the graphic study of intersection between two circular right cylinders of different radius with coplanar and orthogonal axes. The random nature of the choice of which cutting planes could be used for this study leads to subjective results, affected also by different graphic tools (for example manual drawing or Computer Aided Architectural Design (CAAD) bring different typologies of error) [2]. The auxiliary planes, here, were chosen to respect the uniformly distribution of the information about the development of the surface starting from the angular subdivision of the circular section.

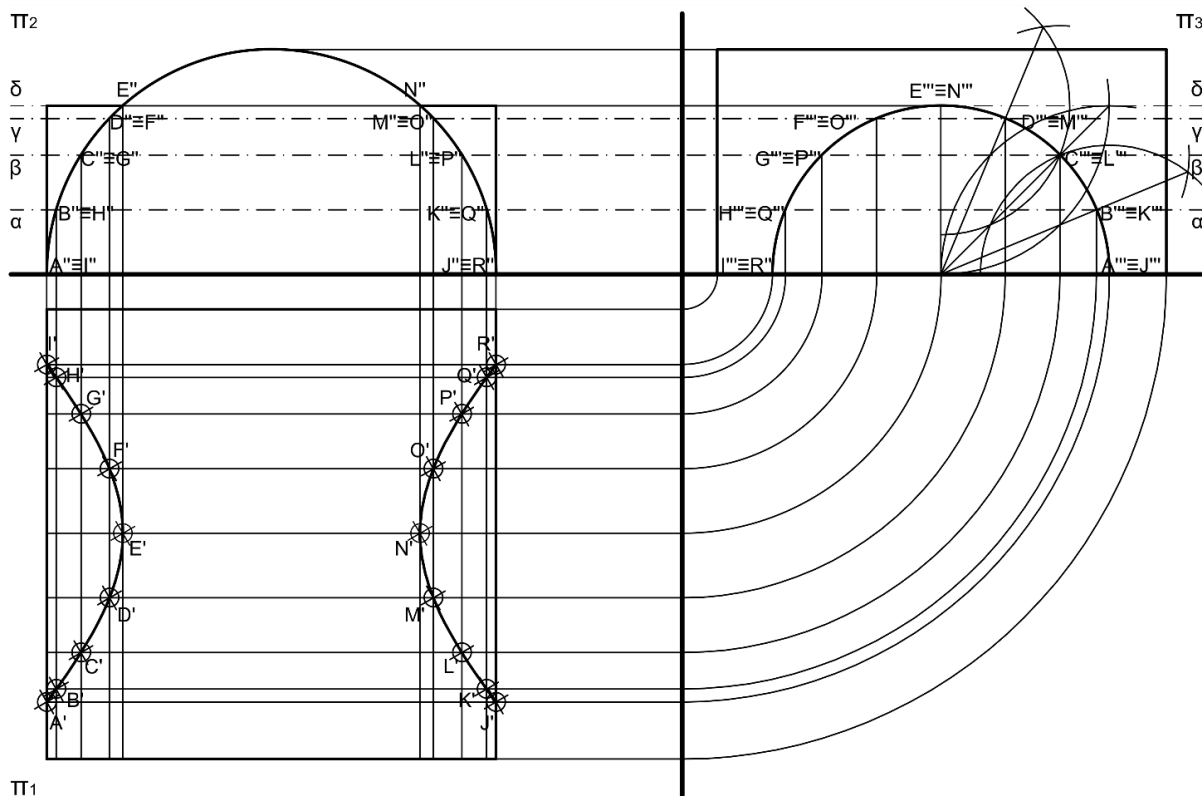

Figure 4: CAAD orthographic projection of the intersection between two barrel vaults.

DGS Analysis

Over the last few decades, the appearance of DGS has renewed Mathematics education providing computational and visual tools available in software environments like *Geogebra*, (Arzarello, F., Bartolini Bussi., M. G., Leung, A., Mariotti, M. A., & Stevenson, I. 2012).

In our context visualization is a crucial matter, in particular in 3D Geometry, but analytic methods may lead to heavy and unilluminating computations and students' mathematical background does not allow them to be autonomous in the visualization of mathematical objects. In the specific case, a surface generated by an intersection of cylinders can be studied in an interdisciplinary activity, making a joint usage of CAAD together with a DGS, which gives the possibility of approaching problems from different perspectives, connecting algebraic and geometrical views, facilitating constructions of mathematical objects and also the direct manipulation of them.

Due to the learners' small knowledge about 3D Analytic Geometry, a ready-made GeoGebra model is proposed, which is realized using an analytical description based on parametric equations of the involved geometric objects.

Let C_1 and C_2 be two semicircular cylinders with coplanar orthogonal axes and different radiuses $R_1 > R_2$. Let $\gamma = C_1 \cap C_2$ be the intersection curve of the two cylinders (see Figure 5), where C_1 is the cylinder generated by translation along the x -axis of the semi-circumference with center in the origin and radius R_1 , in the plane (yz) and C_2 the cylinder generated by translation along the y -axis of the semi-circumference with center in the origin and radius R_2 , in the plane (xz); taking parametric representations $C_1: (x, y, z) = (v, R_1 \sin(u), R_1 \cos(u))$ and $C_2: (x, y, z) = (R_2 \sin(u), v, R_2 \cos(u))$, $-\frac{\pi}{2} \leq u \leq \frac{\pi}{2}$, the quartic skew intersection curve $\gamma = C_1 \cap C_2$ may be represented by:

$$\gamma: (x, y, z) = \left(\pm \sqrt{R_2^2 - R_1^2 \cos^2(u)}, R_1 \sin(u), R_1 \cos(u) \right)$$

In order to visually understand the surface, GeoGebra dynamics are exploited, see Figure 5. As the software enables to rotate a still picture using the mouse, the drawing in Figure 6 shows how to visualize the orthographic projections of the intersection curve $\gamma = C_1 \cap C_2$.

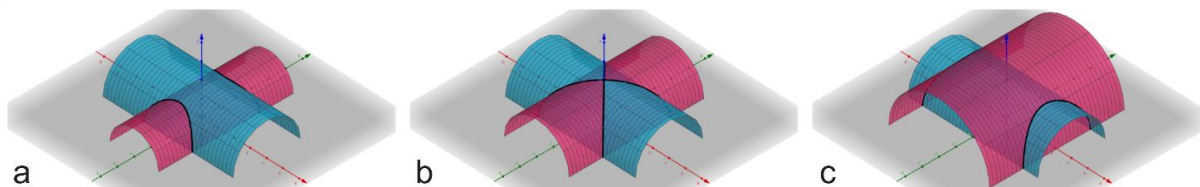

Figure 5: Frames from the dynamic DGS model using a slider to change the red cylinder radius.

We may compare the graphic outcome above with the GeoGebra one: it is clear that the DGS representation is univocal in contrast with the graphic one that is affected by approximations due to drawing choices.

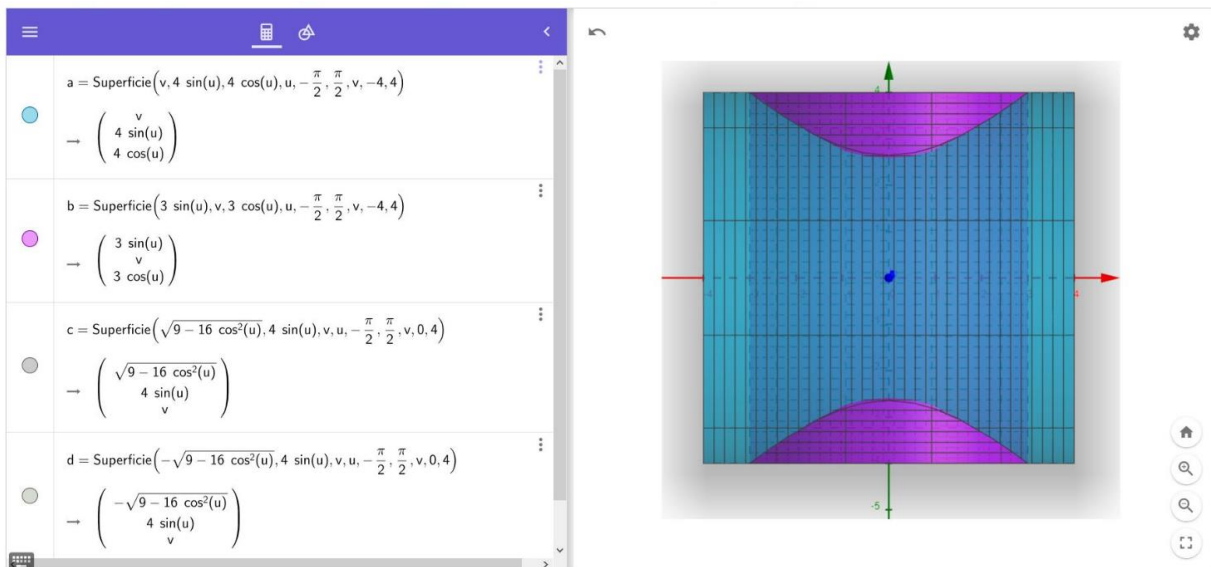

Figure 6: Top view of the barrel vault with lunettes obtained by GeoGebra.

Another way to enhance students understanding is to introduce a real parameter t , replacing the given cylinder C_2 with a 1-parameter family of cylinders: in this way, a slider bar enables to manipulate directly the surface thus generated (see Figure 5, 6) and to follow in particular the deformations of the curve γ , as the parameter varies, while, by suitably rotating this dynamic picture, as it was done in Figure 6, the orthographic projection of γ on the plane (xy) appears easily as subset of a 1-parameter family of hyperbolas.

Physical Models

Starting from the same analytic description as above, a physical model of a barrel vault with lunettes has been realized, using acetate or paper (Figure 7a, c).

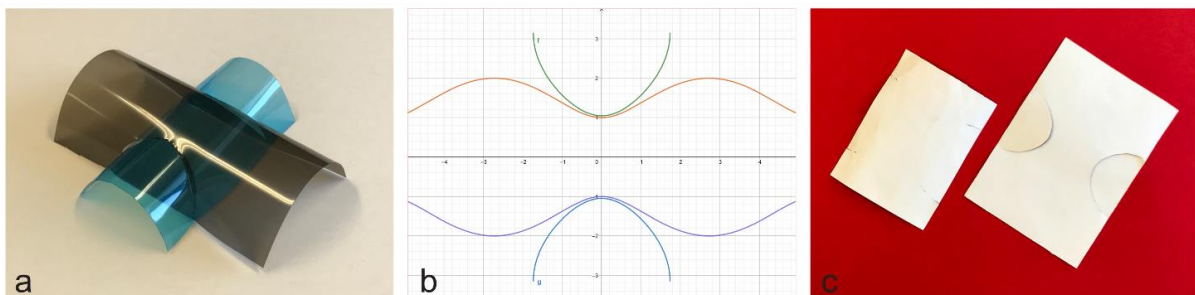

Figure 7: Physical model of a barrel vault with lunettes. a) acetate model; b) developments of the same intersection curve thought as belonging to C_1 or C_2 ; c) disassembled paper model (similar to the acetate one).

If the semicircular cylinders have the same radius, their intersection is a plane curve (generating a cloister or a groin vault, see Figure 3, b and c) and in this case students can realize that its development is a sinusoidal curve using basic elements of trigonometry (see Cumino et alii 2018); if the radiuses are of different lengths, the intersection curve of the cylinders is in general a skew curve, therefore, to obtain its development in the plane requires more sophisticated mathematical tools (e.g. the concept of development of a spatial curve on the plane and the arc-length calculation, see e.g. M. P. Do Carmo (1976), which do not belong to a standard Calculus course program. Nevertheless, the model may be used as a tangible object to communicate the particular shape of the surface under consideration, because it facilitates the geometric perception of the shape as a whole and also the understanding of the geometric properties of the intersection curve; in fact, disassembling the model one observes that this skew curve develops on the plane in two distinct ways (see Figure 8b), depending on whether it is considered belonging to the cylinder C_1 or to cylinder C_2 . Then introducing the arc-length formula, the development of γ on the plane (xy) , as a curve on C_1 , may be represented by

$$\gamma': (x, y, z) = \left(\pm \sqrt{R_2^2 - R_1^2 \cos^2(u)}, R_1 u, 0 \right)$$

In a similar way the development of γ as a curve on C_2 , may be represented by

$$\gamma'': (x, y, z) = \left(R_2 u, \pm \sqrt{R_1^2 - R_2^2 \cos^2(u)}, 0 \right)$$

With respective cartesian equations

$$\gamma': y = \pm R_1 \cos^{-1} \frac{\sqrt{R_2^2 - x^2}}{R_1} \quad \text{and} \quad \gamma'': y = \pm \sqrt{R_1^2 - R_2^2 \cos^2 \left(\frac{x}{R_2} \right)}$$

CONCLUSIONS AND OUTLOOK

In the present paper, we considered how mathematical thinking may contribute in the formalization of architectural structures, using the specific case of barrel vault with lunettes. Our activity was born in an Architectural Drawing and Survey Laboratory, whose main purpose is to make students understand the use of drawing as a tool of analysis and synthesis and as a means to communicate and visualize geometrical objects. The dialogue between Mathematics and Architecture has brought to light a way of interpreting and using Geometry different from that usually practiced by Mathematics teachers.

We took into account Duval's analysis of visualization process and its interactions with geometrical reasoning, adapting it to the particular educational context in regard to 2D/3D graphical representation of a real object and exploration of geometrical situations via physical or digital model; we exploited the experience of teaching

Mathematics in order to make students aware of the variability of representations of an object (depending of the variety of physical or semiotic systems producing them) versus the invariance of the object itself. We present the geometrical reasoning that underpin strategic choices in the graphical description process. To do this, the teacher has to choose a specific set of points and lines that best describe the considered shape; to disclose how to make these choices, physical or digital models are employed, constructed according to a mathematical recipe: the same model which is used by the Mathematics teacher as a tool to teach Geometry. Therefore, the model appears to be, in a sense, a translator between the two disciplinary approaches. Further research in this direction may provide new means to promote a stronger interdisciplinary educational system and to enhance students' spatial and visualization abilities.

NOTES

1. There might be a connection between the idea of tacit model and the architectural design process: if we think of architectural artefacts as results of the creative application of Geometry and its basic elements. In this sense, such elements could act as tacit models for the first architectural composition/shapes recognition exercises.
2. «It is not possible to consider all the points of a surface when you need to represent it. The same is true for all the lines that belong to it. In order to proceed, it is necessary to transform the surface into a discrete set of lines: those that best lend themselves to describe its geometry», Migliari 2001, p. 160.

ACKNOWLEDGEMENTS

The authors C. Cumino is member of the National Group for Algebraic and Geometric Structures and their Applications (GNSAGA-INDAM). For authors M. Pavignano and U. Zich the contribution was developed within the research project MAG.IA.2019: Mathematics Architecture Geometry. Interconnections and Applications. We thank the Centro Studi Residenze Reali Sabaude, Venaria Reale, Torino, for granting us the permission of using pictures in Figure 3.

REFERENCES

- Arzarello, F., Bartolini Bussi., M. G., Leung, A., Mariotti, M. A., & Stevenson, I. (2012). Experimental approaches to theoretical thinking in the mathematics classroom: artefacts and proofs. In G. Hanna, & M. de Villiers (Eds.), *Proof and Proving in Mathematics Education: The 19th ICMI Study Serie* (97–146). Heidelberg: Springer.
- Bertocci, S., & Bini, M. (2012). *Manuale di rilievo architettonico e urbano*. Novara: CittaStudi.
- Calvano, M. (2019). *Disegno digitale esplicito*. Ariccia: Aracne.
- Cumino, C., Pavignano, M., Spreafico, M. L., & Zich, U. (2019). Teaching geometry and surfaces evaluation through graphic representation and dynamic paper models. In L. Cocchiarella (Ed.), *ICGG 2018 - Proceedings of the 18th International*

Conference on Geometry and Graphics (1523–1532). Cham: Springer.
doi:10.1007/978-3-319-95588-9_135

- Do Carmo, M. P. (1976). *Differential Geometry of Curves and Surfaces*. Englewood Cliffs: Prentice-Hall.
- Docci, M., Gaiani, M., & Maestri, D. (2017). *Scienza del disegno*. Novara: CittaStudi.
- Duval, E. (1999). Representation, Vision and Visualization: Cognitive Functions in Mathematical Thinking. Basic Issues for Learning. In: *Proceedings of the 21st Annual Meeting of the North American Chapter of the International Group for the Psychology of Mathematics Education*. Cuernavaca, Morelos, Mexico, October 23–26 (3–26).
- Fallavollita, F. (2009). Le volte composte. In R. Migliari (Ed.), *Geometria descrittiva. Volume II. Tecniche e applicazioni* (447–461). Novara: CittàStudi.
- Fischbein, E. (1989). Tacit Models and Mathematical Reasoning, *For the Learning of Mathematics*, 9(2), 9–14.
- Guarini, G. (1737). *Architettura civile*. Torino: Gianfrancesco Mairesse.
<https://doi.org/10.3931/e-rara-31>
- Harris, D., Black, L., Hernandez-Martinez, P., Pepin, B., Williams, J., & TransMaths Team (2015). Mathematics and its value for engineering students: what are the implications for teaching? *International Journal of Mathematical Education in Science and Technology*, 46(3), 321–336.
- Howson, A. G., Kahane, L., Lauginie, M., & Tuckheim, M. (1988). Mathematics as a service Subject. *ICMI Studies*. Cambridge: Cambridge Books.
<http://dx.doi.org/10.1017/CBO9781139013505>
- Jones, K., & Tzekaki, M. (2016). Research on the teaching and learning of geometry. In A. Gutiérrez, G. Leder & P. Boero (Eds.), *The Second Handbook of Research on the Psychology of Mathematics Education: The Journey Continues* (109–149). Rotterdam: Sense.
- Kovačević, N. (2017) Spatial reasoning in mathematics. In Z. Kolar-Begović, R. Kolar-Šuper, & L. Jukić Matić, L. (Eds.), *Mathematics education as a science and a profession* (45–65). Osijek: Element.
- Migliari, R. (2001). *Geometria dei modelli*. Roma: Edizioni Kappa.
- Palladio, A. (1570). *I quattro libri dell'architettura*. Venezia: Domenico de' Franceschi.
- Rasmussen, C., Marrongelle, K., & Borba, M. C. (2014). Research on calculus: what do we know and where do we need to go? *ZDM Math. Education*, 46(4), 507–515.
- Spallone, R., & Vitali, M. (2017). Volte stellari e planteriane negli atri barocchi in Torino | Star-shaped and Planterian vaults in Turin baroque atria. Ariccia: Aracne.