

Proposal of a simplified Coulomb friction numerical model for the preliminary design of electrohydraulic servomechanisms

Original

Proposal of a simplified Coulomb friction numerical model for the preliminary design of electrohydraulic servomechanisms / Dalla Vedova, M.D.L., Salente, E.. - In: JOURNAL OF PHYSICS. CONFERENCE SERIES. - ISSN 1742-6588. - ELETTRONICO. - 1603:(2020). (4th International Conference on Applied Physics, Simulation and Computing, APSAC 2020) [10.1088/1742-6596/1603/1/012015].

Availability:

This version is available at: 11583/2855145 since: 2020-12-09T02:11:33Z

Publisher:

IOP Publishing

Published

DOI:10.1088/1742-6596/1603/1/012015

Terms of use:

This article is made available under terms and conditions as specified in the corresponding bibliographic description in the repository

Publisher copyright

(Article begins on next page)

PAPER • OPEN ACCESS

Proposal of a simplified Coulomb friction numerical model for the preliminary design of electrohydraulic servomechanisms

To cite this article: M D L Dalla Vedova and E Salente 2020 *J. Phys.: Conf. Ser.* **1603** 012015

View the [article online](#) for updates and enhancements.



IOP | ebooks™

Bringing together innovative digital publishing with leading authors from the global scientific community.

Start exploring the collection—download the first chapter of every title for free.

Proposal of a simplified Coulomb friction numerical model for the preliminary design of electrohydraulic servomechanisms

M D L Dalla Vedova¹ and E Salente²

¹ Assistant Professor, Dept. of Mechanical and Aerospace Engineering, Politecnico di Torino, 10129 Turin (IT)

² Assistant Researcher, Dept. of Mechanical and Aerospace Engineering, Politecnico di Torino, 10129 Turin (IT)

E-mail: matteo.dallavedova@polito.it

Abstract. Electrohydraulic servomechanisms (EHAs) are particularly interesting for aviation application, in fact tanks to the high power to weight ration are widely diffused in medium to large cargo and passengers planes or fighters. This work is focused on the proposal of a new dry friction numerical algorithm, based upon Coulomb's approach, which can be integrated into simulation algorithms obtained by degrading the systems dynamic models (e.g. an over-damped second-order system reducible to a simpler first-order one). This approach, if correctly applied, significantly reduces the computational burden, without significant losses in simulation accuracy. The authors evaluated the approach proposed by a numerical test bench simulating the behaviour of an electrohydraulic linear actuator commonly used in primary flight controls.

1. Introduction

In aerospace, electrohydraulic servomechanisms are particularly interesting for main command surfaces, thanks to their high power to weight ratio. This kind of servomechanism can be implemented in a fly-by-wire architecture, for high precision controls and pilots' workload reduction.

As shown in [1], the simulation of the dynamic behaviors of these systems may require mathematical models evaluating the usually unwanted effects of dry friction forces, which affect more or less all working conditions. In addition, if the considered servomechanism is equipped with mechanical end-of-strokes, their effect must be adequately taken into account by the model itself, without compromising the correct simulation of dry friction. Generally, whichever actuators types are, the motion transmission consists of a certain number of shafts, gears, screws, ballscrews, epicyclical gears, and so on, neglecting driving belts and pulleys. The motion transmission elements are generally affected by dry friction, which may give rise to reversible or irreversible behavior of the whole system [2-3]. So, the potentially relevant effect of the dry friction on the dynamic performance of the mechanical system requires proper simulation models able to provide, at the same time, high computational accuracy, compactness, and efficiency. To this purpose, numerous numerical models are available in the literature [4] which, although with different fields of use and levels of detail, allows simulating frictional effects (e.g. Karnopp [5], Quinn [6], Borello [1], Dahl [7], LuGre [8], elasto-plastic [9-10], Leuven [11] or GMS friction models [12]). It should be noted that, in general, these friction algorithms are integrated within larger numerical models able to provide a suitably detailed simulation of the dynamic response of the mechanical systems in question [13].



Usually, these models describe the main characteristics of the simulated on-board devices, e.g. electrohydraulic [14] or electromechanical actuators [15-16], by non-linear mathematical models of a sufficiently high order and with a suitable number of degrees of freedom [17]. Therefore, accurate modelling of a considered mechatronic system generally implies the use of high order dynamic models (typically, of second-order nonlinear or higher). Vice versa, from a more general system point of view it should be noted that, like many other mechanical problems, also this actuation system can be brought back to a mass-damping-stiffness (M-C-K) second-order model. In some cases, when the inertial component of the system is negligible, its dynamic response approximates the behavior of the corresponding first-order model. In these cases degradation could be possible, obtaining a meaningful cost-saving in calculation time, and at the same negligible reduction of simulation accuracy.

2. Proposed simplified Coulomb friction numerical model

In general, dry friction is generated between two moving mechanical elements; it can be considered as a force opposed to motion whose direction of application depends on the direction of the velocity vector. This concept is represented by the Coulomb friction model [18], summarized as follows:

- in static conditions, when the velocity vector is zero, the frictional force (F_F) is an equal and opposite vector to the applied moving force (T_A) until this assumes the value of the limit static frictional force value (F_{SJ}) (incipient motion condition);
- in dynamic conditions, when the velocity is not zero, the friction force assumes a modulus equal to the dynamic friction force (F_{DJ}) and the vector opposes the motion.

The classical Coulomb friction model can be generally represented by the following relationships, taking into account the difference between sticking and slipping conditions:

$$F_F = \begin{cases} T_A, & \text{if } v = 0 \wedge |T_A| \leq F_{SJ} \\ F_{SJ} \operatorname{sign}(T_A), & \text{if } v = 0 \wedge |T_A| > F_{SJ} \\ F_{DJ} \operatorname{sign}(T_A), & \text{if } v \neq 0 \end{cases} \quad (1)$$

where F_{SJ} and F_{DJ} represent the friction force in sticking and slipping conditions respectively, T_A is the active force and v represents the relative slipping velocity. However, by analyzing this mathematical model, it is easy to recognize how it manifests a marked discontinuity at the zero speed.

In fact, in this condition, the friction force is not determined a priori but, instead, depends on the boundary conditions (i.e. on the value of the net force acting on the system). Various friction models are available in the literature that addresses this nonlinear issue by proposing different methods [19] (for instance, linearization, dead band, discontinuous model, etc.); however, although with different levels of approximation and inaccuracy, all these approaches fall into error in describing the transition between sticking and slipping conditions (or vice versa).

2.1. Mathematical model and Simulink implementation of the proposed friction algorithm

The new friction model is derived from the algorithm proposed Borello et al. in [19]. Fundamentally, if compared to the previously mentioned friction models, it allows to:

- provide the sign of the friction force according to the direction of speed;
- distinguish sticking and slipping conditions;
- evaluate the starting or stop of the mechanical element;
- keep the mechanical element stationary or moving;
- be integrated into the dynamic model of second-order (or higher) non-linear systems.

This Borello's dry friction model can stop the actuation at the moment in which a zero speed passage is detected. This zero-crossing algorithm can be described with the following algorithm:

$$v(t_{i+1}) = 0 \quad \text{if } v(t_{i+1}) \cdot v(t_i) \leq 0 \quad (2)$$

In an instant immediately following, the value of the active force (T_A) is compared with the maximum static friction force (F_{SJ}): if in modulus, T_A is higher than F_{SJ} , the system starts to move in the opposite direction, otherwise it stops. In the Simulink algorithm, this zero-crossing control provides an output signal (Reset DX), which is used as a reset on the speed reset port.

The piecewise formulation of the Coulomb friction model, maintained in the Borello formulation, cannot be linearized locally near the zero speed condition, since it includes a step discontinuity. As a result, a transfer function formulation cannot be obtained to prove stability in this condition. Conversely, for $v \neq 0$ the friction contribution is constant, and the stability characteristics of the dynamical model in which the friction algorithm has been included are maintained. Additionally, as oppose to alternative models (e.g. Karnopp [5] and Quinn [6]) the Borello formulation is independent from the integration timestep: as a result, it does not pose any additional constraints on the minimum timestep dimension for numerical integration.

Furthermore, the proposed algorithm is specifically designed to be integrated within dynamic models degraded to the first order (and, therefore, represented by a mathematical model in which inertial terms do not appear). In this case, being the inertial term negligible, the instantaneous value of the actuation speed (DX) is obtained directly from the net acting force (calculated as the sum of the instantaneous values of the friction force F_F and the applied moving force T_A)

As shown in Figure 1, the friction algorithm proposed derives from that devised by Borello et al., but its structure (and therefore, its block diagram) is modified as follows:

- the calculation of the instantaneous speed supplied as output by the model (DX) is performed through the memory block shown in Figure 1(b), which allows interrupting the algebraic loop which, otherwise, would be established inside the speed reset loop ;
- the Reset DX , which determines the switching between the static (adhesion) and dynamic (sliding) models, and the sign of the instantaneous value of the Friction force are also obtained as a function of the actuation speed calculated in the previous integration step (this delay is performed through a Memory block) to avoid algebraic loops or numerical troubles.

The friction model adds a limited number (in the order of 10) of arithmetic operations to be executed at each timestep, as represented in the block diagrams of Figure 1. That is negligible with respect to the operations usually needed to compute a single timestep of the whole dynamical model of the actuator. The dimension of the timestep is limited by the characteristic time of the actuator model, and the addition of the simulation of friction does not require to modify it. As a result, the proposed model has a negligible effect on the computational burden associated with the simulation.

3. Numerical model of the considered electrohydraulic actuator

The actuation system examined, as shown in Figure 2(a), is a typical electro-hydraulic position servo mechanism widely used in both flight controls of the primary and secondary aircraft.

As described in [15], it consists of three subsystems, indicated below:

- a controller subsystem generally composed of control electronics and a servo amplifier (SA). Frequently, it uses a PID control logic (proportional integral derivative) to provides a low power electric actuation signal, which is the difference between the command input signal and the feedback signal generated by the feedback transducer;

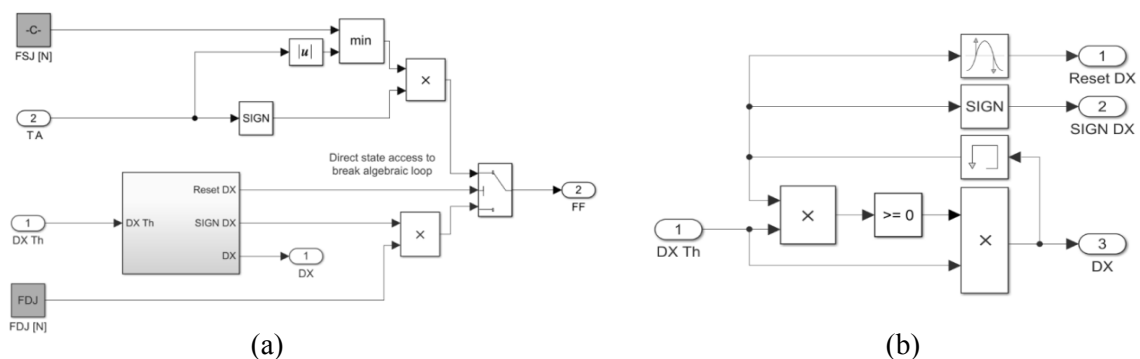

Figure 1. (a) Matlab-Simulink block diagram of the authors' simplified dry friction numerical model. (b) Detail of the "zero-crossing" subsystem with "Time-Delay" block to avoid algebraic loops.

- a two-stage electro-hydraulic servovalve (SV) which, on the base of the low power SA electrical signal, regulates the power provided by the hydraulic fluid to the actuation element;
- a hydraulic piston (symmetrical double-acting linear cylinder subject to Coulomb friction), supplied by a network of position transducers, which drives the controlled device.

As shown in the Simulink block diagram shown in Figure 2 (b), the linear actuator is generally modeled using a second-order nonlinear model. Besides, in the hypothesis that the inertial term of the above model is negligible, a second first-order nonlinear dynamic model has been developed. In the complete EHA model, referring to [15], the hydraulic piston acceleration is calculated as:

$$\frac{d^2x_J}{dt^2} = \frac{1}{M_J} \left(F_{12} - F_R - C_J \cdot \frac{dx_J}{dt} - F_F \right) \tag{3}$$

where x_J is the position of the piston, M_J is its mass, F_{12} is the hydraulic force, F_R is the load force, C_J is the viscous friction coefficient, and F_F is the dry friction force computed with the proposed Borello model. On the other hand, if the inertial term is negligible, the instantaneous value of the speed is directly calculated as the ratio between the forces acting on the system and a viscous coefficient (C_{eq}):

$$\frac{dx_J}{dt} = \frac{F_{12} - F_R - F_F}{C_{eq}} \tag{4}$$

where C_{eq} is an equivalent dimensional coefficient taking into account the fluid dynamic losses due to the oil flowing through the servovalve regulating ports and the damping effects on the jack. This modified formulation allows to improve numerical stability when the inertia of the system is small, and a very short timestep would be needed for numerical integration with the complete formulation of Equation (3).

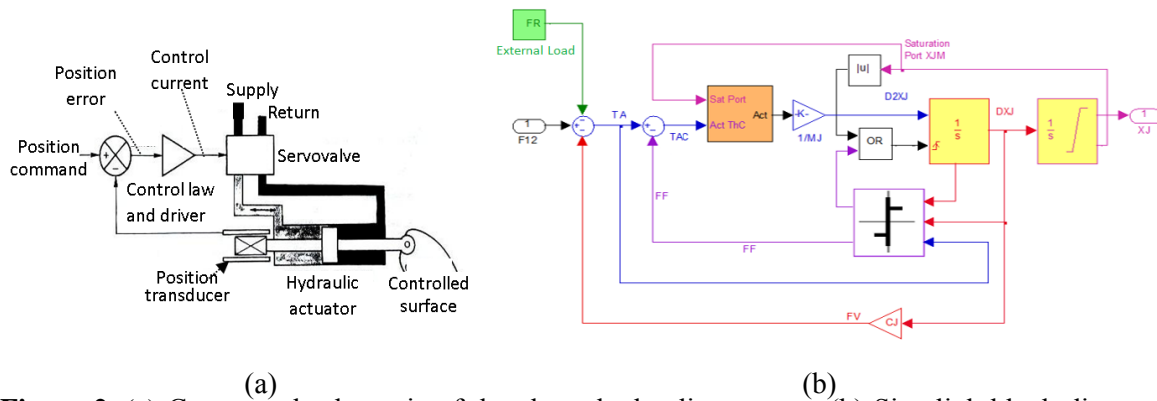

Figure 2. (a) Conceptual schematic of the electrohydraulic actuator. (b) Simulink block diagram of the dynamic second-order model of the EHA linear jack integrating the Borello friction algorithm [15].

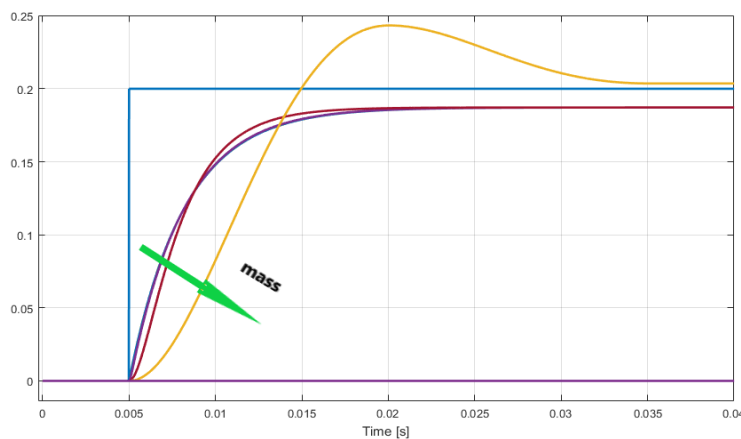

Figure 3. EHA Dynamic response for a step command of 0.2 m. Comparison, as the actuator mass varies, between the second-order model and the corresponding first-order degraded one. The jack mass varies from 0.1 kg (purple line) to 1000 kg (yellow) in a logarithmic progression. The response of the first-order model is not visible because it almost overlaps the response of the second-order system of mass 0.1 kg.

4. Results

To evaluate the performance of the proposed friction algorithm, we compared the dynamic responses generated by the detailed numerical model with those obtained with the actuator model degraded to the first order. The response of the high-order system was tested by varying the mass of the actuator from 0.1 kg (purple line) to 1000 kg (yellow) based on a logarithmic progression of the system inertia. Figure 3 shows the models response for a step command of 0.2 m, applied at time = 0.005 seconds. Note that, as their mass decreases, the dynamic answers provided by the second-order models tend to pack closer to those of the first order, both in the start-up transient and in stationary conditions (e.g. static positioning error due to friction). In this case, the response of the first-order model cannot be found in Figure 3 because it overlaps the low-inertia second-order one having a mass of 0.1 kg.

5. Conclusions

On the base of these preliminary results, it is possible to state that, at least for small inertia values, the proposed first-order degraded model would represent a suitable approximation of the higher-order dynamic model. In all considered cases, the responses for the first-order model results suitably consistent with and low inertia second-order ones. As said before, the degradation allows simulation cost-saving, which is particularly important when a quick simulation is required, or low computational power is available. In the case of systems with negligible inertia (or degraded to first-order dynamic systems), the proposed Coulomb's friction model gives satisfactory performance and perfectly in line with that provided by the corresponding higher-order model. In particular, the proposed model can correctly describe the starting, stopping, and reversing conditions of motion and provide an accurate estimate of the effect of friction on the performance of the actuator.

References

- [1] Borello L and Dalla Vedova M D L 2012 A dry friction model and robust computational algorithm for reversible or irreversible motion transmissions *International Journal of Mechanics and Control (JoMaC)* **13**(02) pp 37-48.
- [2] Borello L, Villero G and Dalla Vedova M D L 2009 New asymmetry monitoring techniques: effects on attitude control *Aerospace Science and Technology* **13**(8) pp 475-487.
- [3] Borello L, Villero G and Dalla Vedova M D L 2014 Flap failure and aircraft controllability: Developments in asymmetry monitoring techniques *Journal of Mechanical Science and Technology* **28**(11) pp 4593-4603.
- [4] Liu Y F, Li J, Zhang Z M, Hu X H and Zhang W J 2015 Experimental comparison of five friction models on the same test-bed of the micro stick-slip motion system *Mechanical Sciences* **6** pp 15-28.
- [5] Karnopp D 1985 Computer simulation of stick-slip friction in mechanical dynamic systems *Journal of Dynamic Systems, Measurement, and Control* **107**(1) pp 100-103.
- [6] Quinn D 2004 A new regularization of Coulomb friction *Journal of Vibration and Acoustics* Vol. **126**(3) pp 391-397.
- [7] Dahl P R 1968 A solid friction model *Tech. Report Tor-0158(3107-18)-1* Aerospace Corporation.
- [8] Canudas de Wit C, Olsson H, Åström K J and Lischinsky P 1995 A New Model for Control of Systems with Friction *IEEE Transactions on Automatic Control* **40** pp 419-425.
- [9] Kikuuwe R, Takesue N, Sano ., Mochiyama H and Fujimoto H 2005 Fixed-step friction simulation: from classical coulomb model to modern continuous models *International Conference on Intelligent Robots and Systems IEEE/RSJ 2005* pp 3910-3917.
- [10] Dupont P, Armstrong B and Hayward V 2000 Elasto-plastic friction model: contact compliance and stiction *Proceedings of the American Control Conference* **2** pp 1072-1077.
- [11] Swevers J, Al-Bender F, Ganseman C G and Prajogo T 2000 An integrated friction model structure with improved presliding behaviour for accurate friction compensation *IEEE Transactions on Automatic Control* **45** pp 675-686.

- [12] Lampaert V, Swevers J and Al-Bender F 2002 Modification of the Leuven integrated friction model structure *IEEE Transactions on Automatic Control* **47** pp 683-687.
- [13] Borello L and Villero G 2000 Flap control system actuators: mathematical and computational model for dynamic simulation *European Congress on Computational Methods in Applied Sciences and Engineering ECCOMAS 2000* (Barcelona, Spain).
- [14] Borello L, Dalla Vedova M D L, Jacazio G and Sorli M 2009 A prognostic model for electrohydraulic servovalves *Annual Conference of the Prognostics and Health Management Society (PHM 2009)*.
- [15] Dalla Vedova M D L, Maggiore P and Pace L 2014 Proposal of prognostic parametric method applied to an electrohydraulic servomechanism affected by multiple failures *WSEAS Transactions on Environment and Development* **10** pp 478-490.
- [16] Dalla Vedova M D L, Germanà A and Maggiore P 2016 Proposal of a new simulated annealing model-based fault identification technique applied to flight control EM actuators *Risk, Reliability and Safety: Innovating Theory and Practice - Proceedings of the 26th European Safety and Reliability Conference (ESREL 2016)* pp 313-321.
- [17] Belmonte D, Dalla Vedova M D L and Maggiore P 2015 Electromechanical servomechanisms affected by motor static eccentricity: Proposal of fault evaluation algorithm based on spectral analysis techniques *Safety and Reliability of Complex Engineered Systems - Proceedings of the 25th European Safety and Reliability Conference (ESREL 2015)* pp 2365-2372.
- [18] Popova E and Popov V L 2015 The research works of Coulomb and Amontons and generalized laws of friction *Friction* **3**(2) pp 183-190.
- [19] Borello L, Maggiore P, Villero G and Dalla Vedova M D L 2010 A comparison between dry friction discontinuous computational algorithms *27th Congress of the International Council of the Aeronautical Sciences 2010 (ICAS 2010)* **5** pp 3750-3759.