

Environmental & flight control system architecture optimization from a family concept design perspective

*Original*

Environmental & flight control system architecture optimization from a family concept design perspective / Cabaleiro de la Hoz, C.; Bussemaker, J. H.; Fioriti, M.; Boggero, L.; Ciampa, P. D.; Nagel, B.. - ELETTRONICO. - 1:(2020), pp. 1-17. (AIAA AVIATION 2020 FORUM2020) [10.2514/6.2020-3113].

*Availability:*

This version is available at: 11583/2854222 since: 2021-01-12T14:50:24Z

*Publisher:*

American Institute of Aeronautics and Astronautics Inc, AIAA

*Published*

DOI:10.2514/6.2020-3113

*Terms of use:*

This article is made available under terms and conditions as specified in the corresponding bibliographic description in the repository

*Publisher copyright*

(Article begins on next page)

# Environmental Control System Architecture Optimization from a Family Concept Design Perspective

C. Cabaleiro de la Hoz<sup>1</sup>, J.H. Bussemaker<sup>2</sup>

*DLR, German Aerospace Center, Hamburg, Germany*

M. Fioriti<sup>3</sup>

*Politecnico di Torino, Turin, Italy*

L. Boggero<sup>4</sup>, P.D. Ciampa<sup>5</sup> and B. Nagel<sup>6</sup>

*DLR, German Aerospace Center, Hamburg, Germany*

To reduce development and manufacturing costs, OEM's often resort to family concept design: each product family member is designed for a different design point, but a significant amount of components is shared among the family members. Here, a trade-off exists between member performance and commonality. In the design of systems, many different architectures are usually possible, and the design space is too large to explore exhaustively. In this work, we present an application of a new architecture optimization method to the design of a family of Environmental Control Systems (ECS). The architecture design space is modeled using the Architecture Design Space Graph (ADSG). Then, decisions are extracted and the multi-objective optimization problem is automatically formulated. Objectives used are acquisition cost, representing savings due to commonality, and the operating costs, representing family member performance. These metrics are quantified using a cross-organizational collaborative multidisciplinary analysis toolchain, and the resulting Multidisciplinary Design Optimization (MDO) problem is solved using a multi-objective evolutionary algorithm.

## I. Nomenclature

$A_{fus}$	=	Fuselage wet area
$A_{transp}$	=	Fuselage transparent area
ADSG	=	Architecture Design Space Graph
CPACS	=	Common Parametric Aircraft Configuration Scheme
CHL	=	Cabin Heat Load
ECS	=	Environmental Control System

---

<sup>1</sup> Master Thesis Student, MDO group, Institute of System Architectures in Aeronautics, DLR, Hamburg, Germany

<sup>2</sup> Researcher, MDO group, Institute of System Architectures in Aeronautics, DLR, Hamburg, Germany

<sup>3</sup> Assistant Professor, Mechanical and Aerospace Engineering Department, Politecnico di Torino, Turin, Italy, AIAA member

<sup>4</sup> Researcher, MDO group, Institute of System Architectures in Aeronautics, DLR, Hamburg, Germany

<sup>5</sup> Team lead MDO group, Institute of System Architectures in Aeronautics, DLR, Hamburg, Germany

<sup>6</sup> Institute director, Institute of System Architectures in Aeronautics, DLR, Hamburg, Germany

$i$	=	index that represents the $i_{th}$ design (Which family member is currently being iterated)
$j$	=	index that represents the $j_{th}$ product (Which sizing parameter member is currently being iterated)
$MDO$	=	Multidisciplinary Design Optimization
$n$	=	index that represents the number of sizing parameters
$OAD$	=	Overall Aircraft Design
$p$	=	index that represents the number of family members
$PFPF$	=	Product Family Penalty Function commonality value
$\dot{Q}$	=	Heat Load
$SC$	=	Solar Constant
$SFC$	=	Specific Fuel Consumption
$\tau$	=	View Factor
$T_{cabin}$	=	Temperature inside the cabin
$T_{in}$	=	Cabin inlet air temperature
$T_{skin}$	=	Exterior fuselage temperature
$\dot{m}_{ram}$	=	Ram mass flow
$\xi_{HE}$	=	Efficiency parameter for heat exchangers
$\xi_{reh}$	=	Reheater efficiency parameter
$\xi_{cond}$	=	Condenser efficiency parameter
$\xi_{cond}$	=	Primary heat exchanger efficiency parameter
$\xi_{mhe}$	=	Main heat exchanger efficiency parameter
$\pi_c$	=	Compressor pressure ratio
$\pi_{ef}$	=	Electric fan pressure ratio
$\pi_t$	=	Turbine pressure ratio
$\Delta p_{PHE}$	=	Pressure losses in the primary heat exchanger
$\Delta p_{MHE}$	=	Pressure losses in the main heat exchanger

## II. Introduction

In aircraft design, performance improvements in terms of fuel burn reduction are pursued to reduce operating costs and environmental impact. One way of achieving such performance improvements, is by developing innovative system architectures by recombining existing components and technologies. However, due to the combinatorial explosion of alternatives, the design space spanning all possible architecture alternatives usually is too large to enumerate exhaustively. To enable successful design space exploration and the discovery of innovative, performance-improving architectures, numerical optimization methods are needed.

Another problem is that developing a new aircraft takes a long time and needs a large investment. As a result, new aircraft models are usually modifications of previous versions, for example with new engines, added winglets, or a modified fuselage. The original aircraft and its modifications can be seen as an aircraft family. In the past, the main aircraft was usually optimized and after some time modifications were made to extend the market coverage of the family. The problem is that this way of designing does not optimize the whole aircraft family, since the optimum point of one product differs from the optimum point of a product family. New design methods are needed to take this effect into account and to design an aircraft family concurrently.

In this research, we consider the design of an environmental control system (ECS) for a family of aircraft. To do this, a novel system architecture optimization method will be applied, and a collaborative Multidisciplinary Design Optimization (MDO) problem will be formulated to assess architecture performances. Since product family design contains an inherent trade-off between member performance and commonality, the formulated optimization problem will be a multi-objective problem with two objectives: acquisition cost, representing the costs an OEM makes to develop and produce a new aircraft family, and operating costs, representing the aircraft performances. The multidisciplinary toolchain will contain an Overall Aircraft Design (OAD) tool, disciplines specific to the analysis of the ECS, and disciplines related to the assessments of the two metrics. Data is communicated between tools using CPACS, and XML-based aircraft parameterization format, as the common language.

The following sections explain some of the important concepts involved in the posed design problem in more depth.

### **A. Family Concept Design**

Family concept design is a way of covering a certain market area with several products at the same time. The advantage of it is that the development and production cost (and hence the acquisition cost) can be reduced if some parts, pieces or processes are shared among the different products. This is called commonality among members [1-4] and it is wanted to be maximized in order to reduce the costs for the producing company. What family concept design is about is trying to find a way of designing several products which can use common components or manufacturing processes to cover a certain market area. The objective is designing multiple versions of a product at the same time to look for more optimum designs; this is what it is called Set-based design [3].

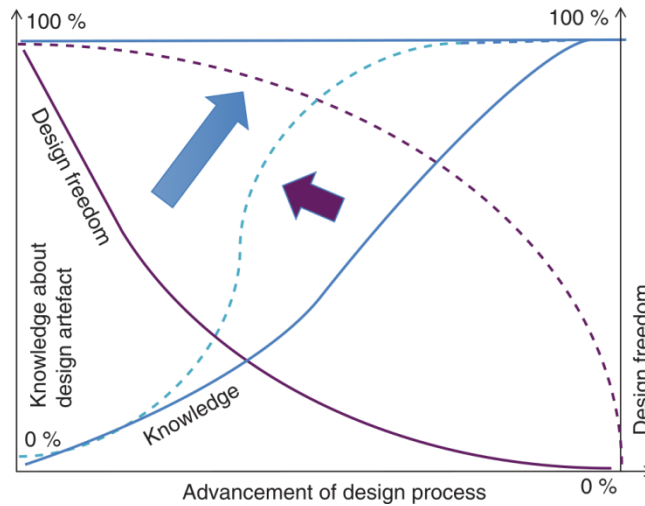
In the aviation sector, when designing a certain aircraft family, the main changes among members are removing or adding fuselage rings and changing the engines. Later some subsystems need to be modified, like tail or control surfaces, in order to fulfill the certification requirements. As an example, an aircraft family could consist of a regular member, a short range version and a long range variation. With these family members a certain market region is covered. Covering that region with good performance means that more aircraft can be sold. The market region in terms of aeronautics is usually given as payload-range diagram. This means that the overall functioning can be represented with some points in the diagram with some associated frequencies that the aircraft will have to cover [5, 6, 7]. Aircraft need to supply different routes, which mean that they fly often out of their design point. The aircraft family optimization will consist on where to position each member in the PL-R diagram and the degree of commonality among the members. Commonality is an abstract concept and it is difficult to evaluate. The method that has been chosen for this case is the Product Family Penalty Function (PFPF) which is explained in the following chapters. The main reason is that it provides with a quantitative way of evaluating commonality and that is what is needed in order to have a more objective evaluation of the quality of the chosen design.

### **B. Collaborative System Architecture Design and Optimization**

In the early design stage, the system architecture is designed. Traditionally, this has been either done based on experience, or by considering only a small amount of alternatives and scoring them based on semi-quantitative metrics, that were usually also based on experience. Such metrics, however, do not offer a detailed description of the real performance of the architecture. This conflict is known as the knowledge paradox: in the early design stage much freedom is available to modify the existing design, but not much knowledge of the system is available [8].

A move towards better methods for quantifying architecture performance has opened the way for analyzing more architecture alternatives in a more detailed manner. The number of possible alternatives, however, can grow so large that analyzing all alternatives is infeasible. Optimization methods are therefore needed to find optimal architectures.

One promising area for the evaluation of product performance is collaborative MDO. Multidisciplinary Design Optimization (MDO) deals with the coupling between different engineering disciplines and how to integrate them in order to perform successful design optimization. Collaborative MDO realizes that in order to perform more elaborate design analysis, it is not practically feasible to have one person setup and execute an MDO problem. Rather, there exists a separation between the disciplinary experts and their analysis tools, and the integrator that has an overview of the design problem, collects tool specifications, arranges access to tool execution, and executes the problem. To reduce the amount of data interfaces that need to be implemented between tools, a common data exchange format is needed: a common language. In the field of aircraft design, CPACS has been established as such a common language, and will be used in this work.



**Fig. 1 Mitigating the knowledge paradox, from [9]**

By connecting system architecting with collaborative MDO, the knowledge paradox is partly mitigated: large design freedom is present, while design performance can be quantified using relatively high-fidelity multidisciplinary expertise, as shown in figure 1. Additionally, by decomposing the architecture in terms of its functions to be fulfilled, as is done in system architecting, extra benefits are achieved: the functional breakdown is generic to any architecture alternative, it does not suggest any architecture concept, and it suggests solution types rather than specific technologies. This results in a framework that is not prone to expert bias, and therefore is suitable for finding innovative new architectures.

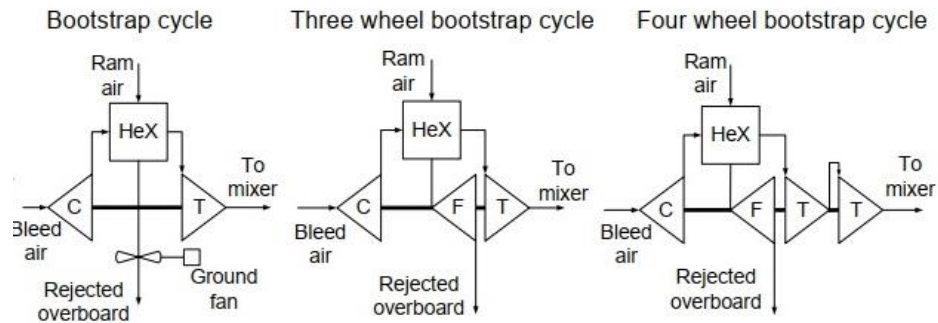
### C. Environmental Control System

The environmental control system ensures that the cabin conditions are adequate, which means that the physiological needs of the passengers and crew are correctly achieved, with some extra comfort demands. The functions include humidity, temperature and pressure control. The minimum and maximum values are fixed by legislation. For instance, in FAR25 a minimum of fresh air mass flow of 4.16 grams per passenger and second are required, but companies usually exceed this minimum. The functioning of the environmental control system can be divided into more subsystems. The air is extracted by the Bleed Air System and then delivered to the Air Conditioning System, which regulates the air conditions and delivers it to the cabin. In order to do this, the air is passed through a primary heat exchanger, then a compressor, a main heat exchanger and finally through a turbine. The heat exchangers cool the air with more air provided by a ram inlet below the fuselage. This system regulates the pressure, temperature and humidity of the air. Once the air is delivered into the cabin, the pressure is controlled by the Cabin Pressure Control System.

One of the main decisions about the ECS' architecture is how to extract the air from the atmosphere. Almost all the aircraft do it with a bleeding from the engines, which is called "conventional way". But for example the B787 uses inlets positioned below the fuselage, and then compresses the air with electric fans. Like this the fuel consumption is not penalized due to the ECS, but the fans' weight is higher than the bleeding system's weight, so there is a trade-off between both decisions.

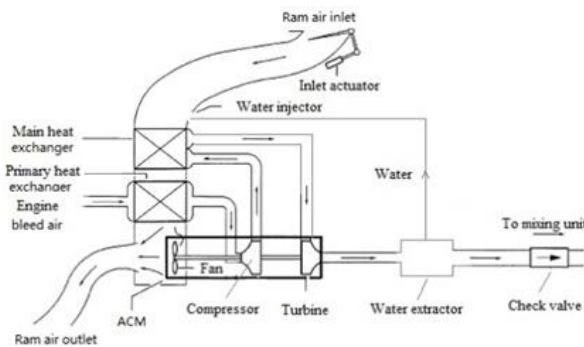
The second main design choice is on which type of Air Conditioning System to use. With this system two decisions can be made. The first one is on how to make the Air Cycle Machine (ACM). This means, how to link the compressor, the turbine and the fan. In this research three different bootstrap cycles are considered, they can be seen in figure 2. The bootstrap cycle (called BC, or two wheel BC) consists just on the turbine moving the compressor, but on ground conditions the ram air has to be provided by an external ground fan. The three wheel BC solves this by linking a fan to the turbine-compressor shaft, hence the ground ram air is provided by this fan and the system is auto-contained (does not need external components in order to function), but as a result the turbine is less efficient

since it has to provide power to another component. The four wheel BC links the compressor to a high pressure turbine and the fan to a low pressure turbine, now each components consumes the exact power needed and the efficiency increases, but as a result there are more components and hence more weight.

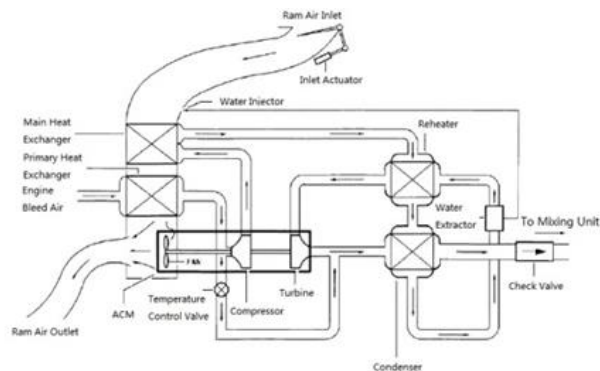


**Fig. 2 Bootstrap Cycle types**

The second design choice about the Air Conditioning System type is on when to extract the water from the air, in order to control the humidity. There are two options to do it. It can be done after the turbine (low pressure water extraction system) or before the turbine (high pressure water extraction system). The advantage of extracting the water before the turbine is that this component can now work at temperatures below zero, and hence the performance increases. But on the other hand new components shall be added, specifically a reheater and a condenser. In figure 3 a three wheel BC with both configurations can be seen.



**Fig. 3a Low Pressure 3 Wheel BC**



**Fig. 3b High Pressure 3 Wheel BC**

To summarize, twelve different ECS configurations are going to be considered for this analysis. They come from all the combinations for the decisions which are: bleedless or conventional way to take the air, using two, three or four wheel BC and having a low or high pressure water extraction system. Some of the combinations can seem to be weird (like a 4 wheel BC with low pressure extractor), but they will be considered and discarded with the genetic algorithms, not before. Like this more possible configurations can be checked.

Depending on the configuration the system will have different weight, specific fuel consumption and reliability. It is known that the wing anti-ice system strongly depends on the ECS, for this reason its effects will be taken into account. For instance, if a bleedless configuration is chosen then the weight of the electric resistances used by this system will be considered.

### III. Optimization Problem

The ECS architecture family will be optimized for two objectives: acquisition cost and operation cost, both of which are attempted to be minimized. Supposing a certain market region input given by historical flight data, the producing company (OEM) should design an aircraft family to cover some part of the market in terms of Payload-Range. For a given aircraft sales price, the more money the aircraft manufacturer needs to invest in order to develop

and produce it, the less profit it will make. On the other hand, the better the product performs the less the operation costs will be for the airline. To improve performance, however, aircraft manufacturer should spend more effort in making every family member work on its optimum point. Introducing commonality can be a way to mitigate this conflict: the larger the commonality among members, the cheaper it will be to develop and produce (more similar product facilities, less design and certification effort, etc.), but the members will operate away from their design point for a larger share of the time and thus overall performance will be penalized.

The main costs for the operator (airline) are all summarized in the DOC (Direct Operational Cost). This cost is divided in several parts: fuel, airport handling, crew salaries, aircraft maintenance costs, engine maintenance, passenger service, administration costs, taxes, revenue management, aircraft rent or price, depreciation and amortization. In this work the ECS is being studied, so only those costs that are directly affected by the ECS performance will be estimated. The model proposed is that the operating cost depends on the fuel consumption and the maintenance cost; both together can be called performance. The fuel price is directly dependent on the specific fuel consumption (SFC), the weight, and the estimated distribution of operating points. The maintenance cost depends on the reliability of the different components and is directly related with the configuration chosen: for example, electric components are more reliable than pneumatic or mechanical ones.

The main costs for the manufacturer (OEM) are the design, manufacturing, and certification costs. This means that if there are more common components, the costs of producing, testing, and certifying will be lower.

#### A. Inputs

The main input will be market segment the family is to be designed for. This information will be provided as a span of payloads and ranges. As aircraft do not operate one single route, a distribution of relative flight frequency over the points in the payload-range segment is needed.

At this time, it is not clear yet whether the number of family members to be designed will be a static input or a design variable.

#### B. Design Variables

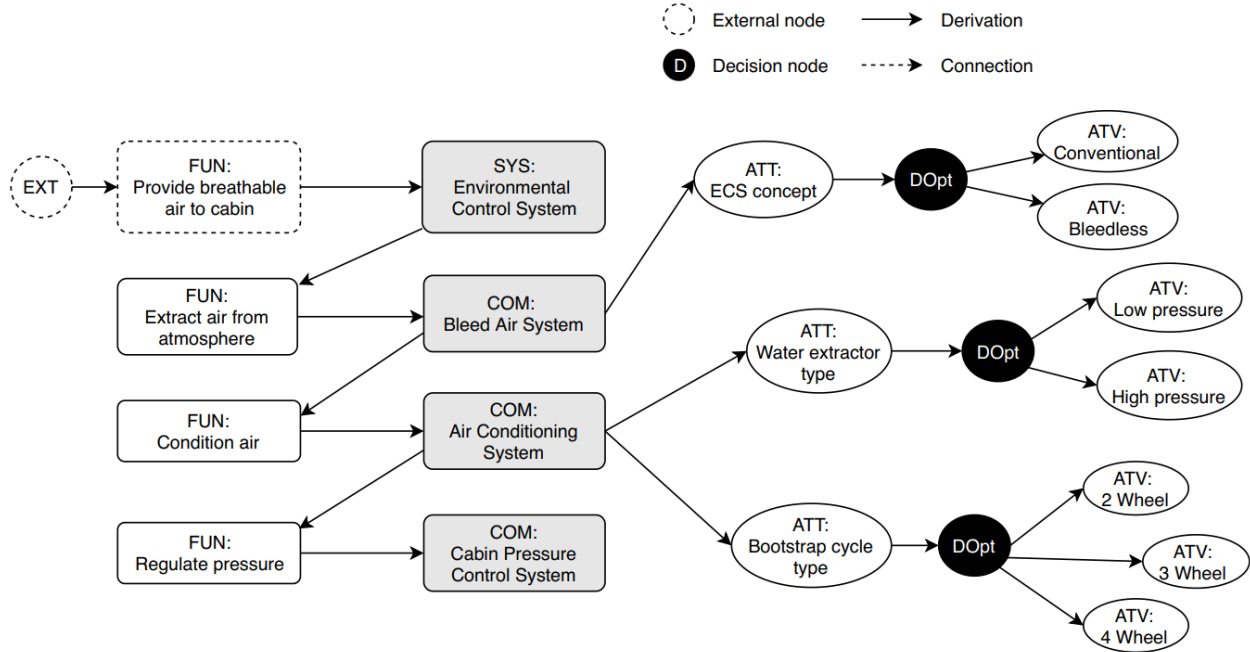
The design variables are those parameters that the optimization algorithms are going to change in order to find the optimum points and obtain the Pareto front. These variables shall reflect the different ECS configurations and the family concept. The following design variables are taken into account:

- **TLARs:** Top Level Aircraft Requirements. Mainly the range and maximum payload of each family member, the other TLAR parameter like Mach number or cruise altitude will be fixed (MPL, R).
- **Off-Design points:** these will be all those off-design points previously discussed. They represent which family member is going to fly each low frequency route ( $PL_{\text{off-design}}$ ,  $R_{\text{off-design}}$ , frequencies).
- **ECS architecture decisions:** which configuration each member will have (Bleedless/Conventional, 2W/3W/4W Bootstrap Cycle, Low/High Pressure Water Extractor). These variables are discrete.
- **ECS cycles' control parameters:** In order to define the configuration some parameters have to be selected. The ones that have been chosen to properly size the configuration are: ( $\pi_t$ ,  $\zeta_{\text{reh}}$ ,  $\zeta_{\text{cond}}$ ,  $\zeta_{\text{mhe}}$ ,  $\dot{m}_{\text{ram}}$ ,  $\pi_{\text{ef}}$ ). Some of them will not be present if the component does not exist in that configuration. The heat exchangers are modeled with just one variable which is the efficiency parameter. In the condenser and reheater this parameter is usually used but in order to reduce the main heat exchanger to just that single parameter the assumption that the ram air mass flow (cold side) is equal or bigger than the ACM mass flow (hot side) shall be made.

### IV. Modeling the Architecture Design Space

To determine the architecture decisions involved in the optimization problem, the architecture design space is modeled first. A novel methodology that enables modeling the design space from a functional perspective is used [10]. This methodology models the architecture design space using the Architecture Design Space Graph (ADSG), which maps functions to components. Additionally, component characterization choices (e.g. related to the number of instances, or to component attributes), and component connection choices are modeled. Decisions are

automatically induced, and these decisions are subsequently mapped to the architecture decisions in the optimization problem.



**Fig. 4 Architecture Design Space Graph (ADSG) of the Environmental Control System (ECS)**

Figure 4 shows the environmental control system function breakdown modeled with the ADSG. It is done from a subsystems level. First, it specifies the neutral function of the system, which is delivering air to the cabin and making it suitable to the physiologic passengers’ conditions. In order to do this, the ECS is divided in three main subsystems (as it was shown in chapter II.C). The Bleed Air System extracts the air from the atmosphere and has an attribute that represents if this is done with a conventional bleeding or from a more electric plane perspective. Then the Air Conditioning System has two attributes that represent the type of ACU and the type of water extractor. The Cabin Pressure Control System just controls the cabin pressure and has no design decisions associated.

The actual system’s model goes more in depth into a component level. The functions specified are divided into smaller ones which can be fulfilled with different components. For instance, one function is “provide ram air on ground” and can be fulfilled by two different components which are an external ground fan or a fan joined to the ACU. If the first one is chosen then the final architecture is what we call two-wheel bootstrap cycle. But, if the second one is selected then a new function appears, which is: “move fan”. Depending on the component that fulfills this new function the final result can be a three-wheel or a four-wheel cycle. Once the architecture design space has been modelled the MDO analysis can be done.

## V. Multidisciplinary Analysis Toolchain

To solve the problem presented in this paper, a multidisciplinary analysis toolchain is established. The developed toolchain is represented as an XDSTM (eXtended Design Structure Matrix) diagram [11], and is shown in the appendix.

The different disciplines communicate their data using a common language: all tools read from and write to a common format to reduce the amount of data interfaces to be implemented. The language used in this project is CPACS: a common language used for aircraft design [12]. Disciplinary tools are integrated in the RCE (Remote Component Environment), a PIDO (Process Integration and Design Optimization) environment developed by the DLR [13]. An in-depth explanation of the different blocks, steps, and loops is presented next.

### A. Optimizer

This block creates the new design variables and receives the solutions from the optimization objectives, which are the costs. The genetic algorithms make this process converge to the optimum solutions in less iteration than the whole possible combinations with the defined design variables. All the variables have their corresponding boundaries and are written into CPACS so all the other tools can properly read them.

### B. Overall Aircraft Design (OAD)

This block sizes the aircraft based on the information from the TLARs. For this analysis OpenAD (previously called VAMPzero) is used. It is a tool for conceptual aircraft design [14] and it was developed to analyze and generate directly CPACS files so there is no need to create an interface for it. Basically it receives the TLARs and estimates the aircraft's masses and dimensions. In this problem the specific inputs are the maximum payload and a range and the required outputs are the MTOW, OEW, fuselage's length and fuselage's diameter.

### C. Cabin Mass Flow

This block receives a fuselage size and a certain amount of passengers. With that information calculates the total cabin heat load and knowing the ECS configuration it dimensions the total mass flow that the system should deliver. The bigger this mass flow the bigger the components and hence the mass. The most demanding scenario is when the aircraft is on ground during a hot day. The first step is estimating the total heat load that the cabin suffers. In order to calculate this value precisely some detailed information needs to be known. But these details are not known on this stage of the design process, so a simplified model with some assumptions can be done. Also some typical values are taken from different databases [15-27]. First of all the total heat load can be expressed as:

$$CHL [W] = \dot{Q}_{sun} + \dot{Q}_{wall} + \dot{Q}_{met} + \dot{Q}_{avionics} \quad (1)$$

The metabolic heat load is calculated by just summing the one produced by the passengers and by the crew members. The avionics heat load is a fix number taken from literature and the other two contributions need a deeper analysis in which the fuselage's transparent and wet areas need to be estimated.

$$\dot{Q}_{sun} [W] = \tau \cdot SC \cdot \frac{A_{transp}}{2} \quad (2)$$

$$\dot{Q}_{wall} [W] = K_{fus} \cdot A_{fus} (T_{skin} - T_{cabin}) \quad (3)$$

The configuration shall be chosen in order to calculate the required mass flow, since this will change the achievable cabin inlet temperature. This value is then compared with the minimum required for that amount of passengers. Some of the values used are in table 1.

$$\dot{m}_{in} = \frac{CHL}{c_p \cdot (T_{cabin} - T_{in})} \quad (4)$$

**Table 1 Parameters on ground and hot day conditions**

Parameter	Value	Parameter	Value
$\dot{Q}$ per passenger	70 W	$T_{skin}$	50°C
$\dot{Q}$ per crew member	200 W	$T_{cabin}$	25°C
$\dot{Q}_{avionics}$	5800 W	$T_{in}$ (low pressure)	14°C
$\tau$	0,9	$T_{in}$ (high pressure)	3°C
$SC$	1367 W/m <sup>2</sup>	$K_{fus}$	1,8 W/m <sup>2</sup> K

### D. ECS thermodynamic cycles

In this analysis the objective is to size all the components of the ECS. Given a configuration, the mass flow requirement and the design variables ( $\pi_{turbine}$ ,  $\zeta_{reheater}$ ,  $\zeta_{condenser}$ ,  $\zeta_{MainHeatExchanger}$ ,  $\dot{m}_{ram}$ ,  $\pi_{electricfan}$ ) all the thermodynamic variables can be solved just making some assumptions. One of these assumptions is that while on ground the 100%

of the bleed air goes through the air conditioning unit (ACU = compressor, heat exchangers, turbine...) and not through valves without being cooled. Also, the recirculated mass flow is fixed in 50% of the total mass flow which is delivered to the cabin. All the mechanical and isentropic efficiencies are taken from similar components. For the conventional ECS the bleeding temperature is always fixed in 200°C. And finally in order to simplify the primary and main heat exchanger, the ram air mass flow is bigger or equal to the ACU mass flow. This last assumption allows modeling the heat exchangers like in Eq. 5. This can be used in all the heat exchangers and the simplification comes since the temperatures can be solved without knowing one of the temperatures. This efficiency represents the cooling capability of the exchanger. Equation 6 represents the general behavior of the heat exchanger.

$$T_{out,hot\ side} = \xi_{HE} \cdot T_{in,cold\ side} + (1 - \xi_{HE}) \cdot T_{in,hot\ side} \quad (5)$$

$$(\Delta T)_{cold\ side} = (\Delta T)_{hot\ side} \quad (6)$$

The fan should provide enough power to move the air through the ram or to compensate the pressure losses on the heat exchangers and the ram inlet and would be linked to the ACU or not depending on the configuration. After all the cycles are calculated some penalties are estimated. These are mainly dependent on the configuration chosen like the reliability, innovation (electric concept needs more development cost), fuel consumption or mass.

The fuel consumption penalty depends on how big the bleeding is and on the amount of power that is extracted from the engine's shaft (bleedless concept fans are usually powered by electric power taken from the shaft). With these values now the true specific fuel consumption (SFC) can be calculated. The components' masses are more difficult to estimate but can also be simplified and calculated from a database. The mass of the compressor and the turbine is linked to the power, and the power they need increases with the mass flow and the pressure ratios as reflected in Eq. (6). There is a correlation between this power and the mass of the component. In the case of the heat exchangers, the pressure loss is mostly dependent on the mass flows once the density is known [28], so it can be simplified as a function of the cold side mass flow. And to estimate the mass the efficiency parameter can be used as seen in Eq. (7). The bigger the efficiency is, the bigger the heat load and hence the bigger the mass. The rest of components like pipes and valves are just taken from other aircraft.

$$Turbine\ Power = \dot{m} \cdot c_p \cdot \Delta T \cdot \eta_{mec}; \quad Compressor\ Power = \frac{\dot{m} c_p \Delta T}{\eta_{mec}}; \quad Mass \propto Power \quad (7)$$

$$\dot{Q} = \dot{m}_{hot\ side} \cdot c_p \cdot \Delta T_{hot\ side} = \dot{m}_{hot\ side} \cdot c_p \cdot \xi_{HE} \cdot (T_{in,hot\ side} - T_{in,cold\ side}); \quad Mass \propto \dot{Q} \quad (8)$$

A step by step process on how to calculate all the variables that are needed is now done. In Fig. 4 the general draft of the system can be seen with all the nomenclature used. From the previous analysis we know the values of mass flow and temperature at the mix manifold exit. On ground conditions the minimum temperature possible is required, so the trim air valve (TAV) mass flow is zero, the valve will be closed. The recirculated mass flow was fixed to a value of the 50% of the cabin mass flow, which means that is equal to the ACU mass flow, and this air is at the same temperature as the cabin. With all these variables calculated, the temperature after the condenser can be solved.



needed (e.g., structural elements). As a result, an increment in a system's weight will result in a bigger increment in terms of OEW and hence also in MTOW.

The objective of this block is to properly size all the family members. So the size of all the family members is then known and fixed (fuselage dimensions, final MTOW and OEW, SFC). After the iteration is reached all the aircraft are properly defined and the next step is checking the degree of convergence between them and how well they perform in terms of fuel consumption.

## F. Commonality

The commonality value can be hard to define and estimate. Some models just consider exactly same components and quantify with a discrete number how many of them there are among all the family members. For this analysis we need a continuous variable that can also take into account how common two components are, and not just if they are the same or different. The proposed model for this article is the PFPF (Product Family Penalty Function). This method evaluates common measurements among components between family members. If a component is common its penalty is zero, but if it is not its penalty will depend on the degree of non-similarity that it has [29]. The following Eq. (8, 9, and 10) model the PFPF.

$$PFPF = \sum_j^n \frac{deviation_j}{\bar{x}_j} \quad (10)$$

$$\bar{x}_j = \sum_i^p \frac{x_{ij}}{p} \quad (11)$$

$$deviation_j = \sqrt{\frac{\sum_i^p (x_{ij} - \bar{x}_j)^2}{p-1}} \quad (12)$$

The result is a PFPF value that represents the commonality level of the aircraft family. The process is the following: some sizing parameters are chosen for each component (characteristic length, diameter, thickness...) and then are compared with the components of the other aircraft to check the degree of commonality. First an average of the value of each sizing parameter is done with Eq. (9) and then the classic standard deviation is calculated with Eq. (10). The PFPF value can now be calculated by summing for each sizing parameter the value of the deviation divided by its average. If all the components are the same among the aircraft members then the PFPF value will be zero, since all the deviations would be null. The bigger the deviation with respect of the average value is, the bigger the PFPF value will be as a result.

## G. Fuel Consumption Model

Once the SFC and the mass are calculated, the total amount of fuel weight can be estimated. In order to do this some enhanced Breguet-equation-based-models are used. Just entering the range, weights, TLARs, SFC and some mission parameters the fuel can be calculated.

The off-design points are now evaluated. Each aircraft will fly some non-optimized routes with some associated frequencies. The result is a weighted average of fuel burn over the payload-range requirement.

## H. Cost models

Now that the commonality has been calculated, the acquisition cost can be estimated. Some penalties can be added if the configuration chosen is bleedless since the design and testing costs will be higher. The proposed model is using TRL models (Technology readiness levels). As a result, the bigger the commonality the lower the acquisition cost, but for the same level of commonality a bleedless configuration will be more expensive to develop than a conventional one.

Regarding the operational cost, the bigger the total amount of fuel needed to supply the routes is, the bigger the cost will be. But also taking into account that electric components are more reliable than pneumatic and hydraulic

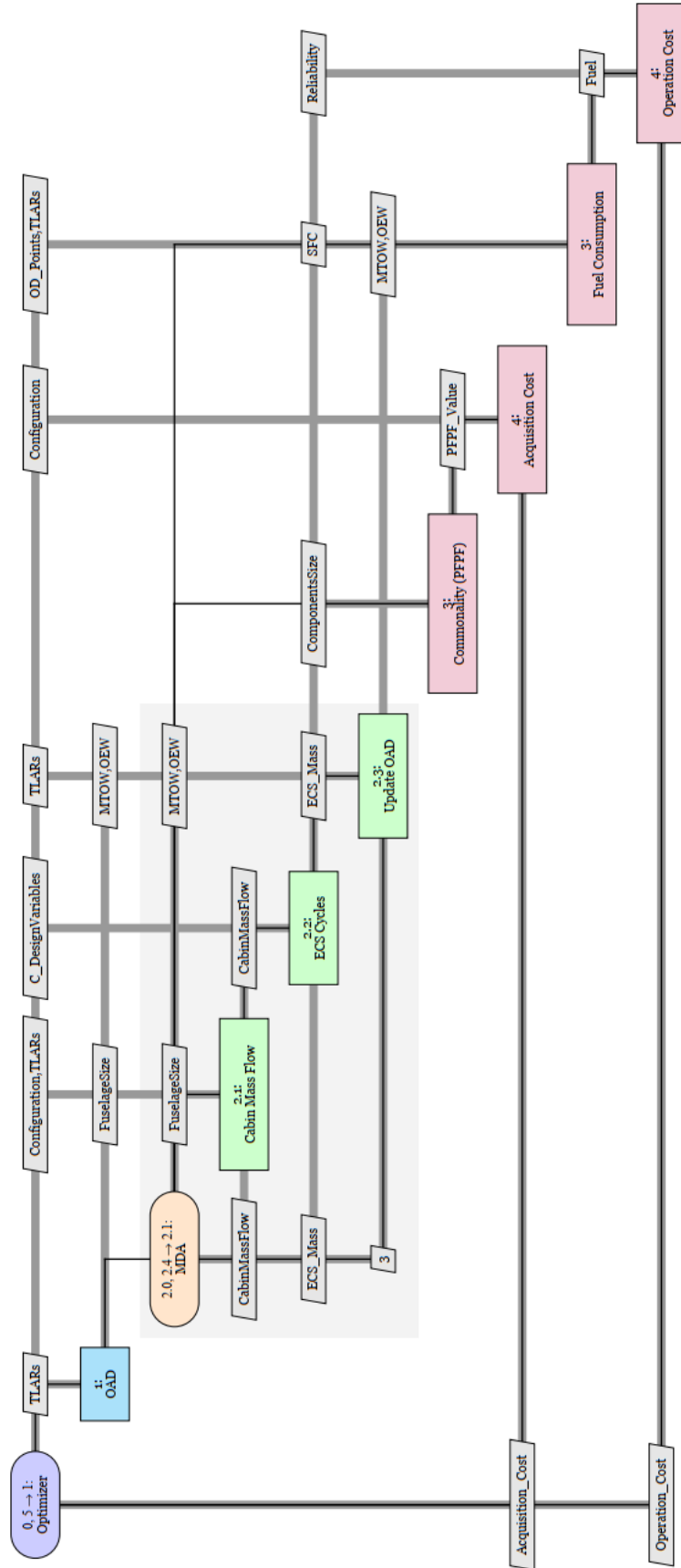
ones, hence more electric aircraft (with bleedless configuration) will have fewer interruptions and less maintenance costs. Some simplified models are used for both cost models.

## **VI. Results**

The results shall be reflected and commented in the final version of this paper once finished. The expected result is the Pareto front between fuel consumption and commonality, and also between the acquisition cost and operation cost. The trade-off between these variables is the origin of this analysis. Depending on the shape of the Pareto front the conclusions can vary. Different degrees of commonality and fuel burn will be obtained for each configuration. After the results are properly analyzed the result shall specify which ECS architecture allows the biggest degree of commonality and which one performs better from a fuel consumption perspective, as well as all the intermediate points that represent the Pareto front.

## **Appendix**

The XDSM can be seen in this appendix. It represents the information workflow among disciplines showing the inputs and outputs of each of them and the overall variables and parameters.



## Acknowledgments

The research presented in this paper has been developed at the Institute of Systems Architectures in Aeronautics of the DLR, in the Aircraft Design & System Integration Department, with direct collaboration with the Polytechnic University of Turin.

## References

- [1] Alberto, J., & Tollenaere, M. (2005) "Modular and platform methods for product family design: literature analysis". *Journal of Intelligent Manufacturing*, 16(3), 373.  
doi: 10.1007/s10845-005-7030-7
- [2] Simpson, T. W., Maier, J. R., & Mistree, F. (2001). "Product platform design: method and application". *Research in engineering Design*, 13(1), 2-22.  
doi: 10.1007/s001630100002
- [3] Simpson, T. W. (2004). "Product platform design and customization: Status and promise". *Ai Edam*, 18(1), 3-20.  
doi: 10.1017/S0890060404040028
- [4] Ulrich, K. (1995). "The role of product architecture in the manufacturing firm". *Research policy*, 24(3), 419-440.  
doi: 10.1016/0048-7333(94)00775-3
- [5] Liem, R., Kenway, G., & Martins, J. (2012, September). "Multi-point, multi-mission, high-fidelity aerostructural optimization of a long-range aircraft configuration". In *12th AIAA Aviation Technology, Integration, and Operations (ATIO) Conference and 14th AIAA/ISSMO Multidisciplinary Analysis and Optimization Conference* (p. 5706).  
doi: 10.2514/6.2012-5706
- [6] Riaz, A., Guenov, M. D., & Molina-Cristobal, A. (2016). "Set-based approach to passenger aircraft family design". *Journal of Aircraft*, 310-326.  
doi: 10.2514/1.C033747
- [7] Mark, G. T. (2005). "Incorporating flexibility into system design: a novel framework and illustrated developments". *Doctoral dissertation, Massachusetts Institute of Technology*.
- [8] Crawley, E., Cameron, B., & Selva, D. (2015). "System architecture: strategy and product development for complex systems". *Prentice Hall Press*.
- [9] Sobieszczanski-Sobieski, J., Morris, A., van Tooren, M.J.L. "Multidisciplinary Design Optimization Supported by Knowledge Based Engineering". 2015.
- [10] Bussemaker, J.H., Ciampa, P.D., Nagel, B. "Modeling the System Architecture Design Space and Automatically Formulating an Optimization Problem". *To be published*.
- [11] Lambe, A. B., & Martins, J. R. (2012). "Extensions to the design structure matrix for the description of multidisciplinary design, analysis, and optimization processes". *Structural and Multidisciplinary Optimization*, 46(2), 273-284.  
doi: 10.1007/s00158-012-0763-y
- [12] Rizzi, A., Zhang, M., Nagel, B., Boehnke, D., & Saquet, P. (2012, January). "Towards a unified framework using CPACS for geometry management in aircraft design". In *50th AIAA aerospace sciences meeting including the new horizons forum and aerospace exposition* (p. 549).
- [13] Moerland, E., Deinert, S., Daoud, F., Dornwald, J., & Nagel, B. (2016). "Collaborative aircraft design using an integrated and distributed multidisciplinary product development process". In *30th Congress of the international council for aeronautical sciences*.
- [14] Böhnke, D., Jepsen, J., Pfeiffer, T., Nagel, B., Gollnick, V., & Liersch, C. (2011, October). "An Integrated Method for Determination of the Oswald Factor in a Multi-Fidelity Design Environment". In *3rd CEAS Air & Space Conference, Venice, Italy*.
- [15] Müller, C., Scholz, D., & Giese, T. (2007). "Dynamic simulation of innovative aircraft air conditioning". *DGLR: Deutscher Luft-und Raumfahrtkongress. Bonn: Deutsche Gesellschaft für Luft-und Raumfahrt*
- [16] Feliot, P., Guennec, Y. L., Bect, J., & Vazquez, E. (2016). "Design of a commercial aircraft environment control system using Bayesian optimization techniques". *arXiv preprint arXiv:1610.02271*.  
doi: 10.1007/s10898-016-0427-3
- [17] Scholz, D., Müller, C., Giese, T., & Erdmann, C. (2007). "FLECS: Functional Library of the Environmental Control System-A Simulation Tool for the Support of Industrial Processes". In *Proceedings of the 1st International Workshop on Aircraft System Technologies* (pp. 143-157).

- [18] Martínez, I. (2014). "Aircraft environmental control". *Academic website webservice. dmt. upm. es/isidoro*.
- [19] Pérez-Grande, I., & Leo, T. J. (2002). "Optimization of a commercial aircraft environmental control system". *Applied thermal engineering*, 22(17), 1885-1904.  
doi: 10.1016/s1359-4311(02)00130-8
- [20] Santos, A. P. P., Andrade, C. R., & Zapparoli, E. L. (2014). "A thermodynamic study of air cycle machine for aeronautical applications". *International Journal of Thermodynamics*, 17(3), 117-125.  
doi: 10.5541/ijot.538
- [21] Maggiore, P., Dalla Vedova, M.D.L., Pace, L., Tosetti, M., Piovano, A. (2014). "Development of an environmental control system pack simulation model for a more electric aircraft".
- [22] Rosales, M.A. (2018). "A preliminar study for selecting and optimizing the environmental control system".
- [23] Bender, D. (2019). "Exergy-based analysis of aircraft environmental control systems and its integration into model-based design".
- [24] Poudel, S. (2019). "Modelling of a Generic Aircraft Environmental Control System in Modelica".
- [25] Mäkelä, L. (2016). "Model-based Fault Diagnosis of an Aircraft Environmental Control System".
- [26] Pollok, A., & Casella, F. (2017). "Comparison of control strategies for aircraft bleed-air systems". *IFAC-PapersOnLine*, 50(1), 14194-14199.
- [27] Peng, X. (2013). "Aircraft environmental control systems modeling for configuration selection".
- [28] Perez Linares, D. (2016). "Modeling and simulation of an aircraft environmental control system" (Doctoral dissertation, École Polytechnique de Montréal).
- [29] Messac, A., Martínez, M., & Simpson, T. (2002). "Introduction of a product family penalty function using physical programming". *In 8th Symposium on Multidisciplinary Analysis and Optimization* (p. 4838).  
doi: 10.2514/6.2000-4838