

Neural Recurrent Approches to Noninvasive Blood Pressure Estimation

Original

Neural Recurrent Approches to Noninvasive Blood Pressure Estimation / Paviglianiti, A., Randazzo, V., Cirrincione, G., Pasero, E.G.A.. - ELETTRONICO. - (2020), pp. 1-7. (2020 International Joint Conference on Neural Networks, IJCNN 2020 Glasgow, United Kingdom, United Kingdom 19-24 July 2020) [10.1109/IJCNN48605.2020.9207317].

Availability:

This version is available at: 11583/2849888 since: 2020-11-10T11:32:20Z

Publisher:

Institute of Electrical and Electronics Engineers Inc.

Published

DOI:10.1109/IJCNN48605.2020.9207317

Terms of use:

This article is made available under terms and conditions as specified in the corresponding bibliographic description in the repository

Publisher copyright

IEEE postprint/Author's Accepted Manuscript

©2020 IEEE. Personal use of this material is permitted. Permission from IEEE must be obtained for all other uses, in any current or future media, including reprinting/republishing this material for advertising or promotional purposes, creating new collecting works, for resale or lists, or reuse of any copyrighted component of this work in other works.

(Article begins on next page)

Neural Recurrent Approches to Noninvasive Blood Pressure Estimation

Annunziata Paviglianiti

*DET - Department of Electronics and Telecommunications
Politecnico di Torino
Turin, Italy
annunziata.paviglianiti@polito.it*

Giansalvo Cirrincione

*Lab. LTI
Université de Picardie Jules Verne
Amiens, France
University of South Pacific,
Suva, Fiji
giansalvo.cirrincione@u-picardie.fr*

Vincenzo Randazzo

*DET - Department of Electronics and Telecommunications
Politecnico di Torino
Turin, Italy
vincenzo.randazzo@polito.it*

Eros Pasero

*DET - Department of Electronics and Telecommunications
Politecnico di Torino
Turin, Italy
eros.pasero@polito.it*

Abstract— This paper presents a comparison between two recurrent neural networks (RNN) for arterial blood pressure (ABP) estimation. ABP is a parameter closely related to the cardiac activity, for this reason its monitoring implies decreasing the risk of heart disease. In order to predict the ABP values (both systolic and diastolic), electrocardiographic (ECG) and photoplethysmographic (PPG) signals are used, separately, as inputs of the networks. To train the artificial neural networks, the synchronized signals are extracted from the Physionet MIMIC database. The output-error Neural networks (NNOE) and the Long Short Term Memory (LSTM) architectures are compared in terms of RMSE and absolute error. NNOE neural network, with ECG signal as input, results the best configuration in terms of both the proposed metrics. The predicted ABP falls within the values of the normative ANSI/AAMI/ ISO 81060- 2:2013 for sphygmomanometer certification.

Keywords—Arterial Blood Pressure, ECG, electrocardiogram, photoplethysmogram, PPG, recurrent neural networks, RNN.

I. INTRODUCTION

High blood pressure (or hypertension) is a worldwide health problem, which represents one of the major causes of premature death in the world, killing roughly 8 million people per year [1]. Hypertension is a condition in which the blood vessels have persistently raised pressure, increasing the pumping function of the heart and leading to hardening of the vessels. Healthy blood pressure is considered as a systolic blood pressure (SBP) less than 120 mmHg and a diastolic blood pressure (DBP) less than 80 mmHg; on the contrary, hypertension is defined as a SBP equal to or above 140 mmHg and/or DBP equal to or above 90 mmHg. Systolic pressure measures the pressure in the arteries when the heart contracts and is the highest number on a blood pressure reading. The diastolic represents blood pressure when the heart rests between the beats. According to the American Heart Association (AHA), it is possible to classify in four different stages the levels of hypertension that characterize the state of health of the individual (healthy, pre-hypertensive, Stage 1 hypertension, Stage 2 hypertension) in relation to the pressure values [2]. Table 1 shows values for normal and high blood pressure.

Continuous monitoring blood pressure can prevent the onset of irreversible health problems (coronary heart disease, stroke, renal failure etc.). Because of hypertension has no symptoms, it is called the *silent killer*.

The medical gold standard method for blood pressure measurement uses sphygmomanometer and Korotkoff sound technique. Unfortunately, this procedure may lead to the misclassification of large numbers of patients because the model has inaccuracies. Indeed, the inherent variability of blood pressure and the tendency for blood pressure to increase in the presence of a physician (the so-called white coat effect) can affect the classification process and consequently prevent the identification of cases in danger [3]. Another measurement method is the intra-arterial blood pressure (IBP), a technique used in the Intensive Care Unit (ICU) and in the operating theatre. This technique involves direct measurement of arterial pressure by inserting a cannula needle in a suitable artery. The advantage is a continuous patient monitoring of the arterial blood pressure (ABP) together with its waveform visualization on a display [4]. Despite the precision, this type of measurement is provided exclusively in the hospital environment because it is very invasive. Therefore, in addition to the inconvenience of measurement, intra-arterial contacts can cause infections [5].

The models proposed in literature for non-invasive neural ABP estimation still have a low prediction reliability for both systolic and diastolic pressures. For this reason, the proposed model aims to overcome the limits of the state of the art with two specific recurrent neural networks, trained with intra-artery pressure measurement model, which is very accurate, as target.

The innovative contribution of the paper is characterized by the idea of a non-invasive method for measuring pressure by means of machine learning (ML) techniques, therefore without an uncomfortable device but still guaranteeing high precision. ML learning techniques, especially deep learning techniques, have been applied to efficiently analyze large data collections in biomedical research field (such as Brain Computer Interface [6], Alzheimer's disease detection [7], Parkinson's Disease detection [8]). Application of these

methods to medical signals can aid the clinicians in clinical decision making.

Rest of the paper is organized as follows. Sec. II carries out an analysis about the studies on cuff-less blood pressure estimation with artificial neural networks. Sec. III describes the methodology of the proposed method. Sec. IV details the experimental results, followed by conclusion in Sec. V.

Table 1. Classification of Hypertension

<i>BP Classification</i>	<i>SBP (mmHg)</i>	<i>DBP (mmHg)</i>
Healthy	< 120	< 80
Prehypertensive	120-139	80-89
Hypertension Stage 1	140-159	90-99
Hypertension Stage 2	> 160	> 100

II. RELATED WORK

Medical research presents several attempts for estimating systolic and diastolic blood pressure with a cuff-less methodology. Pulse Wave Velocity (PWV) represents the propagation velocity of the blood pressure pulse through the circulatory system. Arterial blood pressure can be estimated through PWV using the physical and mathematical description by Moens and Korteweg [9]. The inverse relationship between PWV and ABP is demonstrated by [10]; however, the mathematical model is based on mechanical principles, which use physiological traits difficult to estimate such as artery diameter and distance heart to fingertip. In [11] blood pressure estimation is carried out with the regression technique, but the wave velocity is referred only to the carotid-femoral wave; this is a disadvantage since the estimation of pressure is more convenient to be implemented on wearable devices, which use the wrist pulse wave velocity.

Another parameter used for ABP prediction is Pulse Transit Time (PTT), which is the time taken by pulse wave to propagate from heart to the peripheral points of the body (e.g. fingers or ear lobes). PTT is inversely proportional to PWV and it can be used to measure arterial blood pressure changes continuously. However, PTT is influenced by the compliance of the arterial walls (even to diseases such as osteoporosis) and this make the model not very general and robust [12].

The above cited techniques are generally based on estimated parameters averaged on a quite different population. As a consequence, arterial blood pressure estimation methods do not generalize effectively. Moreover acquiring patient physiological parameters, e.g. artery diameter, is difficult. To overcome these limits, artificial neural network models have been proposed. In [13] they are used to predict ABP values and through a comparison of different neural architectures, the most performing is evaluated.

Our proposed model aims to address a regression problem using two different neural systems (see Sec. III). In order to predict ABP values, photoplethysmography (PPG) signal is used as input of the artificial neural network. Indeed, in literature, blood pressure has been demonstrated to be closely related to PPG [14], which is an optical measurement technique to detect blood volume changes in the microvascular bed of tissue [15]. In addition, since blood pressure is, also, closely related to cardiac activity, neural

architectures have been trained with the electrocardiogram signal (ECG) as input, and compared with the previous ones.

III. METHODOLOGY

In order to treat the problem of estimating blood pressure, two different neural networks were compared: the output-error Neural networks (NNOE) and the Long Short Term Memory (LSTM). The two approaches use recurrence in a different way: the former as a regression vector, the latter straight in its structure. Fig. 1 shows the pipeline used for ABP detection flowchart. In particular:

- Raw Signals: input (ECG or PPG) and target signal (IBP). They were all acquired from the database, filtered with a moving mean (window length equal to 3) and used to train the artificial neural network models.
- The output signal from the network is compared with the target signal in terms of root mean square error (RMSE).
- The target and output signals were characterized by systole points (referring to systolic pressure) and foot points (referring to diastolic pressure). The BP values, both systolic and diastolic, were compared by means of a difference (in mmHg) between targets and output.

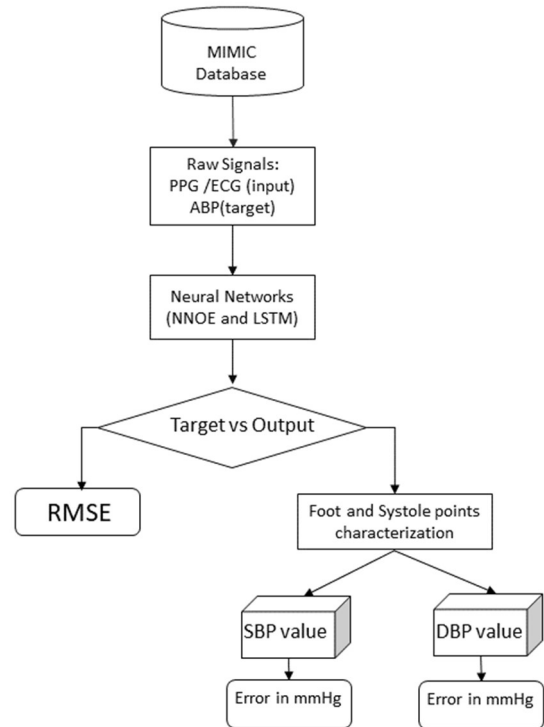

Fig. 1 Methodology flowchart

A. Dataset Description

The signals used for training the networks were extracted from the MIMIC (Multiparameter Intelligent Monitoring in Intensive Care) database [16] [17]. This database includes PPG and ECG, which are used as inputs and the IBP, which is used as training target, for the estimation of the systolic and diastolic blood pressure values. Fig. 2 illustrates the signals of the neural system with the PPG as input signal and the blood pressure as target. Fig. 3 shows the signals about the

neural system with ECG input and IBP target. The resulting training set has 300.000 samples for each signal; two-thirds have been used for training, while the remaining for testing and validation.

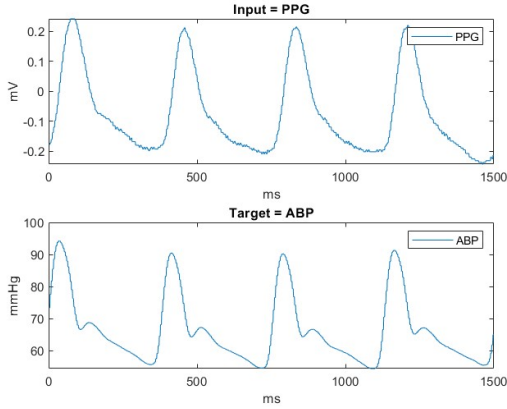

Fig. 2. ECG signal (input) and ABP signal (target)

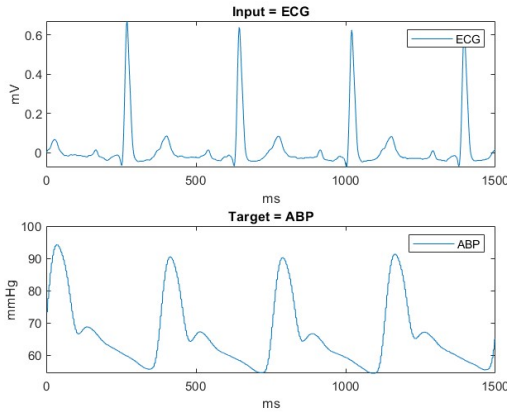

Fig. 3. PPG signal (input) and ABP signal (target)

B. NNOE - Neural Network Output-Error

The purpose of Neural Network Output-Error (NNOE) is the identification of nonlinear dynamic systems in stochastic environment [18]. Fig. 4 describes the procedure that must be executed when attempting to identify a dynamical system.

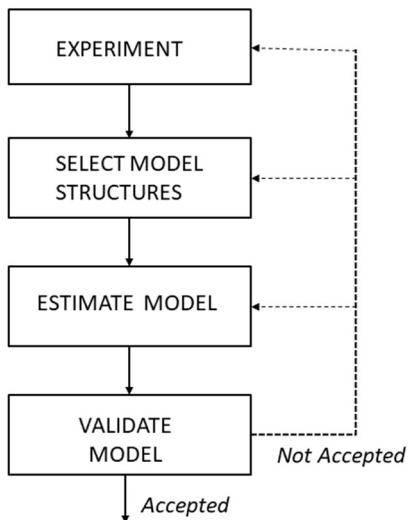

Fig. 4. System identification procedure

The *experimental phase* is represented by the description of the dataset Z^N , which describes the entire system in its operating region with a proper choice of sampling frequency:

$$Z^N = \{[u(t), y(t)]_{t=1, \dots, N}\} \quad (1)$$

$u(t)$ is the control signal, $y(t)$ represents the measured output signal and t specifies sampling instant number.

For the *selection of model structure* is necessary to choose a set of regressors. The goal is to select a number of regressors based on the idea of a linear system identification and then determine the best possible network architecture. The selection of regressors as inputs of the artificial neural network is carried out by Lipschitz method [18], as showed in Fig. 5.

For NNOE, the shape of regression vector is given by:

$$\varphi(t) = [\hat{y}(t-1)\theta \dots \hat{y}(t-n)\theta \quad u(t-d) \dots u(t-d-m)]^T \quad (2)$$

where θ is a vector containing the weights, n is the y -predicted lag, m is the input lag and d the delay to obtain the prediction (also called skip).

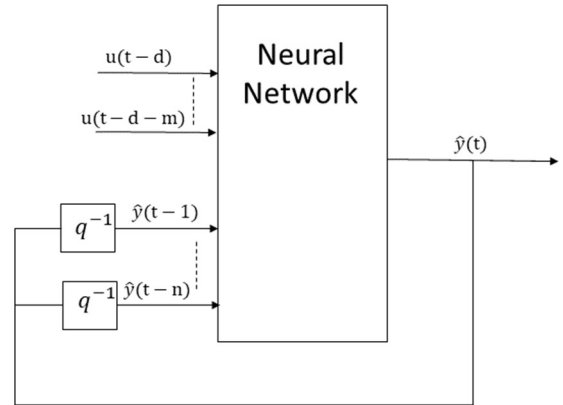

Fig. 5 The NNOE model structure

The prediction vector is the following:

$$\hat{y}(t|\theta) = g(\varphi(t), \theta) \quad (3)$$

where g is the function realized by the artificial neural network. The functions for *estimating model* are based on recurrent networks. The most common method of *validation* is to investigate the residuals (prediction errors) by cross-validation on a test set.

C. LSTM – Long Short Term Memory

Recurrent Neural Network is a generalization of feedforward neural network that has an internal memory. The most popular RNN are the Long Short-Term Memory (LSTM) networks, because makes it easier to remember past data in memory, resolving the vanishing gradient problem of RNN. The LSTM are based on special units called memory blocks (see Fig. 6). Each memory block contained an *input gate*, which controls the flow of input activation, and an *output gate*, which controls the output flow of cell activations

into the rest of the network [19]. The *forget gate* was added to the memory block to scale the internal state of the following cell, before adding it as input to the cell through the self-recurrent connection of the cell, therefore forgetting or resetting the cell's memory [20].

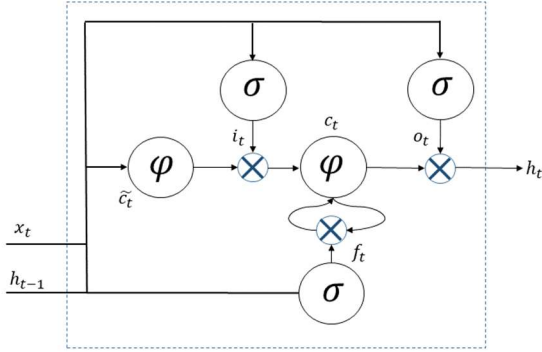

Fig. 6. LSTM memory block

The hidden state (h_t) is created by the following step:

- The *forget gate* tells the cell state which information to forget by multiplying 0 to a position in the matrix.

$$f_t = \sigma(W_f[h_{t-1}, x_t] + b_f) \quad (4)$$

- The *input gate* determines which information should enter the cell state.

$$i_t = \sigma(W_i[h_{t-1}, x_t] + b_i) \quad (5)$$

- The *modulation input gate* allows the cell state to forget memory.

$$\tilde{c}_t = \tanh(W_c[h_{t-1}, x_t] + b_c) \quad (6)$$

- The *output gate* decides what the next hidden state should be.

$$o_t = \sigma(W_o[h_{t-1}, x_t] + b_o) \quad (7)$$

where W presents the weights vector, b the bias and σ the sigmoid function.

The working memory is called the *hidden state*. The hidden state contains information on previous inputs and it is also used for predictions.

$$h_t = o_t * \tanh(c_t) \quad (8)$$

where c_t is the current state of the cell:

$$c_t = f_t * c_{t-1} + i_t * \tilde{c}_t \quad (9)$$

IV. RESULTS

The recurrent networks presented in the previous section have been tested on systolic and diastolic blood pressure estimation task; indeed, it has been divided into two subtasks: ABP estimation with IBP as target and PPG or ECG as input, respectively. Then, their performances have been compared in terms of RMSE and absolute ABP error (in mmHg). Several experiments were carried out for both architectures. In each attempt, at least one hyperparameter was changed, e.g. the number of units. For sake of simplicity, only the best results are reported because the scope of the paper is a comparison on ABP estimation performances rather than training or architecture simplicity.

A. NNOE architecture

The first set of experiments regards the use of NNOE. At the beginning, the number of regressors of the network has been determined with the *Lipschitz quotients method* [21]. Fig. 7 shows the Lipschitz graph, which can be used as a suggestion about the order of the system. The indices for system orders from 1 to 10 are investigated; the system can be modeled by a sixth order model, since the slope of the curve is decreased for model orders greater than 5.

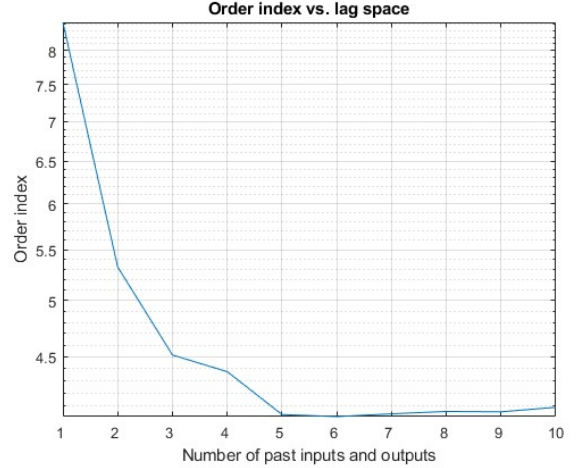

Fig. 7. The order index criterion evaluated with Lipschitz quotients method.

In the application at hand, the NNOE architecture was implemented by a multi-layer perceptron (MLP), because of its capability to learn nonlinear relationship from a set of data. The hidden layer has 35 units for the PPG case and 40 in the ECG one. The activation function is hyperbolic tangent. To train the network Levenberg-Marquardt method is used [22], which is a very accurate technique for feed-forward neural networks w.r.t. the training precision. It acts like a gradient-descent method when the parameters are far from their optimal value, and like the Gauss-Newton method when the parameters are close to their optimal value [23]. The error function is, of course, the sum of squared errors. The network is trained twice: first with PPG signal as input and then with ECG signal as output. Before comparing the output of the network with the target, a moving mean filter (window length equal to 25 and 10, respectively) is applied to the output signal to remove noise artifacts.

Fig. 8 and Fig. 9 show the comparison between target (blue solid line) and output (red dashed line) signals with PPG and ECG as input, respectively. In both cases, the prediction is accurate. The model is evaluated in terms of RMSE; in particular, RMSE shows better performances for NNOE with ECG input (RMSE = 2.42) than PPG (RMSE = 5.80).

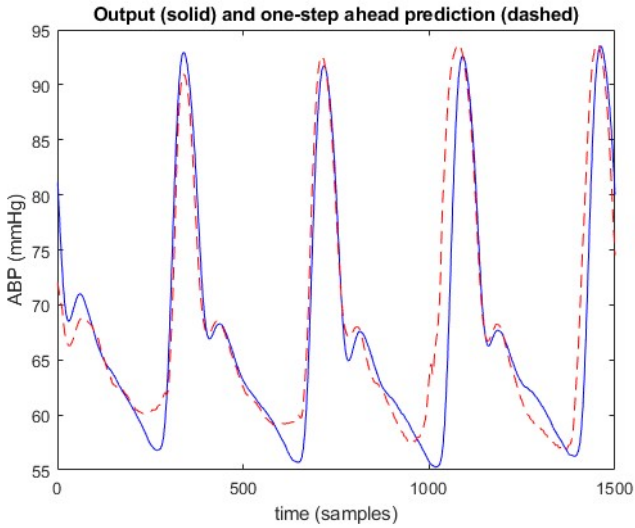

Fig. 8. NNOE - Target vs. output (PPG input)

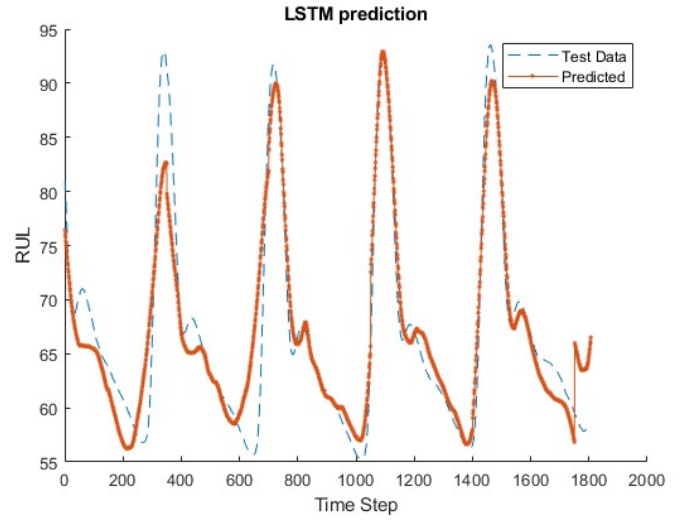

Fig. 10. LSTM – Target vs. Output (PPG input)

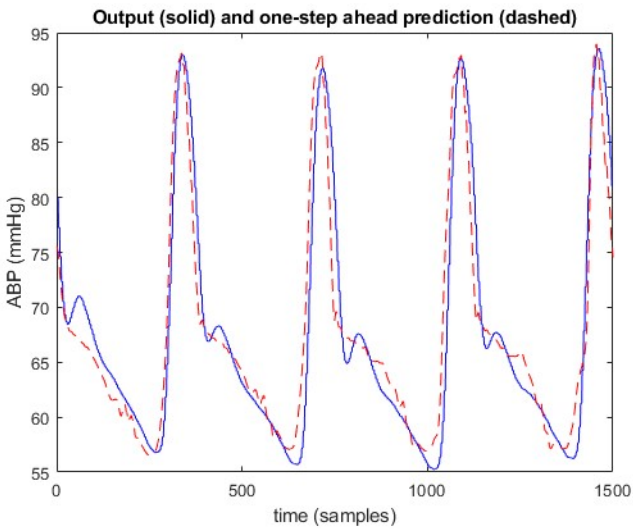

Fig. 9. NNOE - Target vs. output (ECG input)

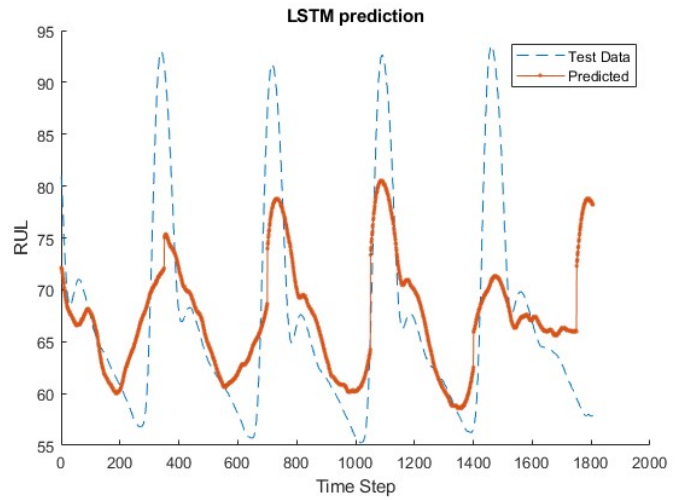

Fig. 11. LSTM –Target vs. Output (ECG input)

B. LSTM architecture

The second experiments deals with an LSTM trained as before: first on PPG, then on ECG. The used LSTM architecture is composed of one input layer (350 neurons), one hidden layer (equipped with 500 neurons) and one regression output layer. To minimize the training error and avoid minimal points Adam optimizer is used. Adam optimizer is an adaptive optimization algorithm, which has witnessed better optimization performance than stochastic gradient descent (SGD), especially for training deep neural networks (DNNs) [24]. Fig. 10 and Fig. 11 show the comparison between target (blue dashed line) and output (orange solid line) signals with PPG and ECG as input, respectively. While the prediction of the blood pressure signal is accurate with the PPG signal, the ECG case is quite bad. This is also confirmed by the RMSE, which, in the first case is equal to 5.35 while with ECG as input reaches 7.43.

C. Performance Assessment

The RMSE is not sufficient to assess the quality of the ABP estimation task. Indeed, it measures the point-to-point differences between two signals. In the application at hand, i.e. the ABP estimation, it is not required that the network is able to fully reproduce the target signal; indeed, only the peaks and valley of the IBP signal are important because they do represent the systolic and diastolic blood pressure, respectively. In this sense, the RMSE can be used as a general metric. To deepen the analysis about the best architecture for ABP estimation, the absolute errors (in mmHg) for SBP and DBP are evaluated for the four configurations. At this purpose, for each neural network and input (PPG/ECG), the characterizing points (foot, systole, notch and dicrotic peak) of the blood pressure signal were extracted both from output and target signals [25]. Fig. 12 shows an example: the systole points (green triangles) represent ABP values referred to the systolic blood pressure, while the foot points (violet triangles) are referred to the diastolic blood pressure. All the systoles and all the foots were averaged to compute SBPs and DBPs both for the target and the output. Then, their difference is evaluated to measure the absolute errors in mmHg.

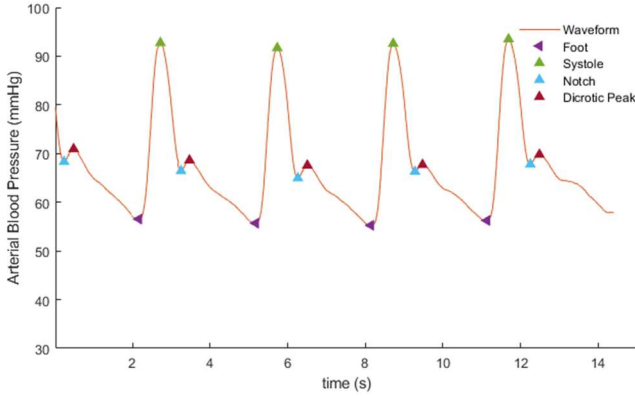

Fig. 12. Characterization of the ABP signal points

Table 2 yields the regression performance of all the tested architectures. In terms of RMSE, the NNOE architecture behaves better with PPG rather than ECG, while LSTM exhibits an opposite response. For the absolute error, NNOE performs conversely w.r.t the RMSE, i.e. the ECG is better, while LSTM maintains the same behavior.

Table 2. RMSE and absolute error performances

		RMSE	absolute error [mmHg]	
			Dias	Sys
NNOE	PPG	5.80	2.36	0.69
	ECG	2.42	1.26	0.7
LSTM	PPG	5.35	1.51	5.26
	ECG	7.43	5.54	12.72

D. Result discussion

The NNOE approach is tailored on the input signals because of the choice of the regressors and the associated lags depend on the database at hand. This point of view considers the method as, basically, a feature selection, unlike the deep learning techniques, which automatically extracts their own attributes. In this sense, the better results of NNOE w.r.t. LSTM are justified by the fact that the regressor choice is better suited for this application. Despite the fact that NNOE requires far less inputs than LSTM (6 vs 350, respectively), the time-sequence is not well understood by the deep approach. However, NNOE works better with ECG than PPG; probably two different sets of regressors are required, and the input layer has been chosen for working with both signals. Indeed, future work will deal with the use of both channels for the neural approach. This can also explain the fact that for LSTM, the contrary is true, i.e. the best results are for PPG. The PPG signal gives a better cue for ABP estimation. This is not true for NNOE, because it is better suited for ECG, but LSTM is able to exploit automatically this advantage.

The results of this application are another example of the debate among neural experts about the way recurrence has to be implemented. Indeed, the two approaches of NNOE and LSTM, as seen before, use recurrence in a different way: the former as a regression vector, the latter straight in its structure. We claim that in this application the NNOE approach is better. The theoretical justification of this statement is out of the scope of this paper.

Finally, NNOE neural network with ECG signal as input is the best configuration in terms of both the proposed metrics. Indeed, the predicted ABP respects the normative ANSI/AAMI/ ISO 81060- 2:2013 for sphygmomanometer certification.

V. CONCLUSIONS

In this research, blood pressure neural based estimation methods are analyzed. ABP is an important physiological parameter, which must be monitored to prevent and detect cardiovascular diseases. The analysis compares two recurrent neural networks for time series prediction: NNOE and LSTM. The former is a network with a number of regressors as inputs, which try to identify nonlinear dynamic systems; the latter is a deep neural network that carries information thanks to memory cells. The regression results are evaluated in term of RMSE and absolute errors. In particular, because of the regressors choice as input, NNOE tackles the problem better. The comparison is addressed also to input configurations (PPG/ECG); the analysis showed that there is no coherent efficient input for both networks. Future works will deal with improving the blood pressure estimation with NNOE method with ECG as input (the best configuration of the analysis), and, also, testing the proposed artificial neural network systems with both ECG and PPG as inputs.

VI. REFERENCES

- [1] W. H. Organization, "High blood pressure: a public health problem," [Online]. Available: <http://www.emro.who.int/media/world-health-day/public-health-problem-factsheet-2013.html>. [Accessed 20 January 2020].
- [2] A. A. Heart, "Understanding Blood Pressure Readings," [Online]. Available: <https://www.heart.org/en/health-topics/high-blood-pressure/understanding-blood-pressure-readings>. [Accessed 8 January 2020].
- [3] T. G. Pickering, J. E. Hall, L. J. Appel, B. E. Falkner, J. Graves, M. N. Hill, D. W. Jones, T. Kurtz, S. G. Sheps and E. J. Roccella, "Recommendations for Blood Pressure Measurement in Humans and Experimental Animals," *AHA Scientific Statement*, pp. 142-161, 2017.
- [4] C. Pellaton, A. Vybornova, S. Fallet, L. Marques, O. Grossenbacher, B. De Marco, V. Chapuis, M. Bertschi, B. S. Alpert and J. Solà, "Accuracy testing of a new optical device for noninvasive estimation of systolic and diastolic blood pressure compared to intra-arterial measurements," *Blood Pressure Monitoring*, 2019.
- [5] C. Ilies, G. Grudev, J. Hedderich, J. Renner, M. Steinfath, B. Bein, N. Haake and R. Hanss, "Comparison of a continuous noninvasive arterial pressure device with invasive measurements in cardiovascular postsurgical intensive care patients: a prospective observational study.," *Eur J Anaesthesiol*, no. 32, p. 20-28, 2015.
- [6] N. Mammone, C. Ieracitano and F. C. Morabito, "A deep CNN approach to decode motor preparation of upper limbs from time-frequency maps of EEG signals at source level," *Neural Networks*, vol. 124, pp. 357-372, 2020.
- [7] "A Convolutional Neural Network approach for classification of dementia stages based on 2D-spectral representation of EEG recordings.," *Ieracitano, Cosimo; Mammone, Nadia; Bramanti, Alessia; Hussain, Amir; Morabito, Francesco C.*, vol. 323, pp. 96-107, 2019.
- [8] H. Gunduz, "Deep Learning-Based Parkinson's Disease Classification Using Vocal Feature Sets," *SPECIAL SECTION ON DEEP LEARNING FOR COMPUTER-AIDED MEDICAL DIAGNOSIS*, vol. 7, 2019.
- [9] F. J. Callaghan, C. F. Babbs, J. Bourland and L. A. Geddes, "The relationship between arterial pulse-wave velocity and pulse frequency at different pressures," *Journal of Medical Engineering & Technology*, vol. VIII, pp. 15-18, 2009.

- [10] R. Wang, W. Jia, M. Zhi-Hong, R. J. Sciabassi and M. Sun, "Cuff-free blood pressure estimation using pulse transit time and heart rate," *Signal Processing Proceedings (ICSP)*, pp. 115-118, 2014.
- [11] B. Mark, H. Peta J, K. Zahra, P. Karen and A. Alberto P, "A simplified method for quantifying the subject-specific relationship between blood pressure and carotid-femoral pulse wave velocity," *37th Annual International Conference of the IEEE Engineering in Medicine and Biology Society (EMBC)*, pp. 5708-5711, 2015.
- [12] R. J. Vidmar, "Physiology and biophysics of the circulation, U.S.A.: Year Book Medical Publishers, 1972.
- [13] Ş. Ümit, Y. İbrahim and P. Kemal, "Repetitive neural network (RNN) based blood pressure estimation using PPG and ECG signals," in *International Symposium on Multidisciplinary Studies and Innovative Technologies (ISMSIT)*, 2018.
- [14] E. C.-P. Chua, S. J. Redmond, G. McDarby and C. Heneghan, "Towards Using Photo-Plethysmogram Amplitude to Measure Blood Pressure During Sleep," *Annals of Biomedical Engineering*, vol. XXXVIII, no. 3, pp. 945-954, 2010.
- [15] J. Allen, "Photoplethysmography and its application in clinical physiological measurement," *Physiological Measurement*, pp. R1-R39, 2007.
- [16] G. B. Moody and R. G. Mark, "A Database to Support Development and Evaluation of Intelligent Intensive Care Monitoring," *Computers in Cardiology*, vol. 23, pp. 657-660, 1996.
- [17] A. Goldberger, L. Amaral, L. Glass, J. Hausdorff, P. Ivanov, R. Mark, J. Mietus, G. Moody, C.-K. Peng and H. Stanley, "PhysioBank, PhysioToolkit, and PhysioNet: Components of a New Research Resource for Complex Physiologic Signals," *Circulation*, pp. e215-e220, 2003.
- [18] M. Nørgaard, O. Ravn, N. K. Paoulsen and L. K. Hansen, *Neural Networks for Modelling and Control of Dynamic Systems*, London: Springer, 2000.
- [19] H. Sak, A. Senior and F. Beaufays, "Long Short-Term Memory Recurrent Neural Network Architectures," *Google, USA*.
- [20] F. A. Gers, N. N. Schraudolph and J. Schmidhuber, "Learning Precise Timing with LSTM Recurrent Networks," *Journal of Machine Learning Research*, vol. III, pp. 115-143, 2002.
- [21] X. He and A. H., "A new method for identifying orders of input-output models for nonlinear dynamic systems," *Proc. of the ACC.*, pp. 2520-2523, 1993.
- [22] K. Levenberg, "A Method for the Solution of Certain Non-Linear Problems in Least Squares," *Quarterly of Applied Mathematics*, vol. 2, no. 2, pp. 164-168, 1944.
- [23] H. P. Gavin, "The Levenberg-Marquardt algorithm for nonlinear least squares curve-fitting problems," pp. 1-19, 2019.
- [24] Z. Zhang, "Improved Adam Optimizer for Deep Neural Networks," *Department of Computer Science*, 2018.
- [25] A. Laurin, "BP_annotate," MATLAB Central File Exchange, 2020. [Online]. Available: https://www.mathworks.com/matlabcentral/fileexchange/60172-bp_annotate. [Accessed 23 April 2020].