

Exact component-wise solutions for 3D free vibration and stress analysis of hybrid steel-concrete composite beams

Original

Exact component-wise solutions for 3D free vibration and stress analysis of hybrid steel-concrete composite beams / Shen, J., Pagani, A., Arruda, M.R.T., Carrera, E.. - In: THIN-WALLED STRUCTURES. - ISSN 0263-8231. - 174:(2022), p. 109094. [[10.1016/j.tws.2022.109094](https://doi.org/10.1016/j.tws.2022.109094)]

Availability:

This version is available at: 11583/2958046 since: 2022-03-11T08:51:11Z

Publisher:

Elsevier Ltd

Published

DOI:[10.1016/j.tws.2022.109094](https://doi.org/10.1016/j.tws.2022.109094)

Terms of use:

This article is made available under terms and conditions as specified in the corresponding bibliographic description in the repository

Publisher copyright

(Article begins on next page)

Direct Online Environment Monitoring of Water Pollution

Monica Periolatto*, Felice Catania, Matteo Manachino, Luciano Scaltrito, Fabrizio Pirri, Sergio Ferrero

Politecnico di Torino – DISAT, C.so Duca degli Abruzzi, 24 10129 Torino (Italy)

monica.periolatto@polito.it

Water pollution is one of the most serious ecological threats we face today. Each water body is affected by some organic, inorganic or radioactive pollutant, coming from direct or indirect sources. Surface water and ground water must currently be monitored in all countries on a very large scale by public authorities, but also private companies, to enforce pollution reduction and environmental law compliance. Most of the controls are performed by manually sampling the waters and by sending the samples to an authorized laboratory for the analysis, with high costs, long response times, low sampling frequency and consequent low monitoring data resolution.

The research aims to develop methods and to design a device able to perform the sampling, preparation and detecting automatically. The proposed system in fact can be easily installed on site and, once configured and positioned, smart sensors can send analytical data directly to the customer with no human intervention. It involves no costs for sampling activities, response times reduced to few minutes and the possibility to achieve high sampling frequency and a consequent strict monitoring of the evolution of the site status. Moreover, the device will be able to collect and share data, according to IoT technology.

1. Introduction

Man-made settlements, pollution and climate change have long been generating problems that can directly influence the quality of supply sources. Continuously increasing contamination levels are detected in water bodies due to fertilizers, heavy metals, pesticides, pathogen microorganisms and recently to microplastics. (Tundisi et al., 2015)

With the recent issue of some regulatory measures (917/2017/R/IDR - Quality regulation), in Italy ARERA (Autorità di Regolazione per Energia Reti e Ambiente) has defined a discipline of the technical quality of the integrated water service. The same National Authority requests the application of innovative technologies in order to be able to achieve significant service level objectives and the quality of the water distributed quickly. Furthermore, 20 years after its entry into force, the European Council Drinking Water Directive (Directive 98/83/EC) is currently subject to revision, through a proposal aimed at reinforcing the laws on water of good quality, focusing on the themes of accessibility, consumer protection, health and safety quality of life, up to the circular economy and sustainable development. The list with the limits relating to microbiological and chemical parameters has been expanded with respect to the current one, with the addition of additional microbiological parameters as well as new and emerging substances, including endocrine disruptors and perfluoroalkyl substances (PFAS). A further very important aspect concerns the more restrictive levels compared to the current ones required for chlorites and chlorates, by-products of the disinfection of drinking water. According to Utilitalia (the Federation that brings together companies operating in the public services of water, the environment and electricity and Gas), in 60% of cases they are not currently effectively monitored.

The design of highly sensitive portable devices for in situ monitoring of environmental pollutants is gaining interest in the last period (Shtepliuk et al., 2019, Wang et al. 2017). Anyway, the selectivity and sensitivity of the proposed methods are still challenging.

Considering this scenario, any improvement in the monitoring of water quality, in terms of reliability, frequency of analysis, widening of detected pollutant and data sharing, are of great interest and can strongly decrease the environmental impact of water pollution. (Periolatto et al., 2019)

2. Experimental

The proposed device was designed as modular, in terms of hardware and software, allowing the detection of heavy metals, organics or surfactants by spectrophotometry, hydrocarbons by GC-FID or plastic microparticles by visual sorting coupled to FTIR.

The experimental study focused first on heavy metals detection, that is Chrome, Copper, Zinc and Nickel, by spectrophotometry. The recommended standard methods were first optimized for miniaturization considering chemical, microfluidic and optical features. The system was able to completely automate the sample preparation phase and, using the lab-on-chip technology, greatly minimize the time and cost of sample preparation. A microfluidic system, consisting of glass syringes, micro pumps and degassing systems, allows to acquire the necessary quantity of water sample, filtering the sample through cascade of filters up to nanoporosity, possibly dilute or concentrate the sample, and mix with any reagent. Then the system was embedded in a portable carrying case and interfaced to the software system, allowing the transmission of data to monitoring units and laboratories LIMS, and possibly to a cloud server via FTP protocol.

Full tests were carried out on Cr(VI) metal ions, detected by 1,5 Diphenylcarbazine (DFC) complexation, followed by spectrophotometric analysis. The optimization of chemical methods involves a technological optimization, in order to transfer all the components of the measurement from the laboratory within a device capable of acting autonomously, that is without the intervention of the operator, having a good operating autonomy, in terms of battery life and long periods without handling, and in order to be installed on-site.

The phases optimized were the measurement phase, aimed to avoid the use of a commercial spectrophotometer, which requiring high space of installation, high costs, high energy consumption, operator; the sample preparation phase, in order to replace operator's manually steps; data reading, collection and interpretation phases.

2.1 Optical design

An optical design step, which involves the correct choice of the light source, the sizing of the optical system for the treatment of the laser beam and its addressing through the sample to be analyzed, was mandatory. Moreover, the proper detector, capable of capturing the absorbance of the sample and a system for conditioning the signal coming from the detector and driving the laser diode, were selected and sized.

The intent was to replace the current wide spectrometer source, which analyzes the absorption of the substance in the visible and ultraviolet range. Among the whole spectrum in fact, the measurement methods exploit exclusively the absorption peak, corresponding to a single wavelength or, in any case, to a very narrow band. The idea was therefore to use a monochromatic light, corresponding to the single wavelength of interest. Moreover, it was decided to use a laser diode, a monochromatic and coherent light source, which therefore allowing a great optical power for the same power consumption, that is a lower consumption of electric power for the same power optics.

Focusing on Cr(VI) detection, the optical analyzer was composed of a PL520 laser source @520 nm, collimated with an ACL 12708U aspherical lens, a multi-chambered cuvette and a silicon photodiode BPW21R as detector. For Zn, the bench prototype consisted of a TO Can laser diode emitting at 638 nm, with an output optical power (CW) of 40 mW, collimated through an aspherical lens.

A proprietary electronic driver was built to drive laser diode current, controlling the laser source, and to read the silicon photodiode detector BPW21R (Vishay).

The optical path of the laser beam from the source, through the sample, to the detector, was designed by a raytracer software (Zemax), to simulate beam parameters and to develop the optical system. (Figure 1)

Mechanical components of the measure chamber were designed by a CAD software (Solidworks), in order to identify dimensions, materials, connections and to realize mechanical drawings for mechanical workshop.

2.2 Measurement chamber

The measurement chamber was subdivided into 4 micro-channels, with a volume of 1 ml each, in order to minimize the reagent quantities. Measurement chamber mechanical design comprised the seats for the gaskets and optical windows, the inlet and outlet channels of the liquid for each channel, and a viton gasket compressed by a lid to guarantee the hydraulic seal. The materials used are AISI 316 steel, with passivation treatment to resist sea water, and glass, to maximize compatibility with chemical compounds.

A mechanical support was also designed and built to ensure correct alignment between all the components of the optical system, namely laser source, measurement chamber, photodetector. A single Anticorodal aluminum base was manufactured, onto which to strip the source-holder supports, the detector-holder supports and the measurement chamber. These couplings allow very tight alignment tolerances, ensuring a measurement phase with minimal optical errors. (Figure 2)

The support was then built and installed. The sources have been realized with commercial anodized aluminum supports, while for the photodetectors ad hoc supports have been designed and manufactured. Alignment tests, power tests and diode stability tests were performed.

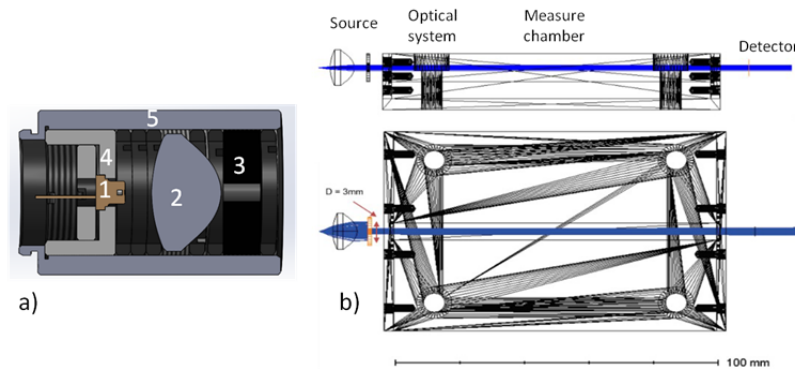

Figure 1: a) Optical system for laser source. 1 Laser diode, 2 Glass lens, 3 Shutter, 4 Mechanical support for laser diode, 5 Mechanical support for entire optical system. b) Optical simulation of laser beam, optical system, measure chamber and detector in Zemax.

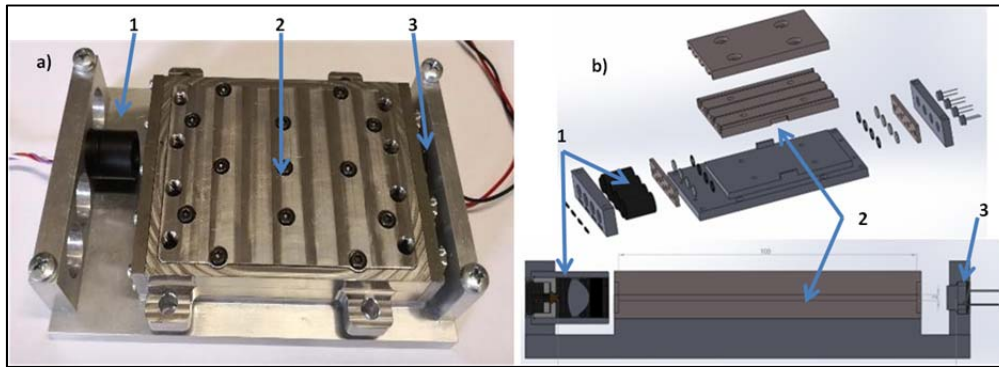

Figure 2: a) Final measure system manufactured. b) Explosion and section of the entire measure system. 1) Source 2) Measurement chamber 3) Detector

2.3 Hydraulic design

The miniaturized laboratory for dissolved metal detection must be arranged and designed in order to explain the monitoring mission, occupying as less space as possible, with as less weight as possible, sampling, making the measurement for the recognition and quantification of the chosen dissolved metals and storing the treated samples for an appropriate discharge at the end of the mission.

Hydraulic circuit was designed by an opensource software (Proficad). The measurement parameters and processes of the optimized chemical methods were converted to obtain automatic measure phases. In detail, the operations are divided into several phases, corresponding to the parts of the hydraulic circuit:

- **Sample Suction:** The water is initially filtered, via sintered filters, outside the portable device: this allows to have spurious elements reduced to a minimum during sample analysis. From the main liquid inlet, the water passes to the filter. Through a valve (EVA1) the water is placed in a 10 mL chamber for subsequent analyzes
- **Rinsing phase:** From here the water enters the mixing chamber, connected directly with EVB4 valve, with the chamber measurement and with another three-way valve (EVB3). Of the three ways of the EVB3 valve, the first one is for water feed, the second is connected to the sampling syringe, while the third is connected to the waste. The sampling syringe collects now an amount of the sample which is used to perform a rinse. In this way it cleans all the tubes. Along the circuit, there are also two bubble traps, consisting of a membrane able to eliminate the bubbles that could form in the circuit. The rinsing is carried

out twice, to further decrease the presence of elements spurious in the measurement chamber, finally the EVB3 valve is switched toward waste, for discharge

- **Blank sample measurement phase:** Now the dosage starts. The water arrives in the mixing chamber with all the valves closed, after which it is taken from the sampling syringe by opening the appropriate EVB4 and EVB3 valves and after switching on the bubble traps. Once it enters the measurement chamber it is analyzed in order to obtain "blank sample". The measurement takes place through the use of laser diodes and photodiodes capable of read the current generated by it once it has crossed the chamber measure, one for each metallic substance to be identified
- **Dosing, mixing and measurement phase:** In the mixing chamber, they come also the required reagents are injected in the proper amount by the two smallest volume syringes present upstream of the mixing chamber. Reagents are stored inside the device for 100 measurements, that is amounts of 10mL of methanol + DFC and 5mL of sulphuric acid. Mixing takes place through a repeated suction cycle, which occurs 5 times, so that the sample and reagents mix at the best of the ways. Before measurement, a further control is expected: if the measure of a metal is greater of the measurement of blank sample, the system continues to measure, in order to obtain an average value avoiding false positives
- **Post-measurement discharge phase:** After the measuring phase, the valve EVB4 is closed and the valve EVB3 switches to waste, where the complexed water residue is preserved. The Storage bag can hold 50 measurements.

The main entrance is made up of plastic tubes leading water to the inside of the carry case via an inlet valve. The middle filter support was designed and tested to support up to 100 bars. Sampling and depressurization are operated by a syringe made of steel (Chemika) with a volume of 20 ml, a motorized axis (Misumi) and mechanical supports designed and manufactured by Cemas Electra Srl. For the choice of syringes that will contain the reagents, glass syringes (borosilicate) with a PTFE plunger (compatible with many strong acids and organic solvents) were chosen.

To obtain a perfect mixing of the complexing agents and the sample volume, a mixing chamber was designed and built. The chamber has grafts on the upper cap for reagent and sample inlet, and its interior has a truncated-cone geometry to optimize mixing, rinsing, and minimize residual volume, which is almost zero after each measurement and rinsing, in order to minimize contamination of the next sample. (Figure 3)

In order to best size the system the following steps have been followed: analysis of the syringe datasheet (volume, stroke, plunger diameter, maximum speed and maximum pressure), analysis of the stoichiometric ratios of reagents and sample, calculation of the number of theoretical samples based on the datasheet, calculation of the physical quantities of reagents (density, dynamic viscosity), pressure loss hypothesis located in the tube syringe interface and its calculation, choice of linear actuator (propeller pitch and starting torque), transformation of the loss of load into the maximum torque allowed to the motor. Once the syringes and the actuator, LX2001P-B1-T2042-150-OP2 (Misumi), have been chosen, the mechanical supports are designed and manufactured and the electronics for driving the stepper motors are designed.

2.4 Electrical device

Three different types of electronic boards were designed and manufactured by Microla Optoelectronics S.r.l.:

- Motherboard, able to communicate with all other boards, management of firmware. An embedded PC was also integrated for software management and communication
- Control board for solenoid valves, capable of managing also the vacuum pumps for the degassing system
- Control board of the motor-driven syringes, which includes the stepper motor driver, and the motor-cycle management firmware, which controls initial syringe capacity and residual capacity.

These boards were then designed, selecting all the components that would reduce the overall dimensions and consumption. (Figure 4)

A management firmware was therefore written for each board, which provides for the integration of all the operations that make up the measurement. The boards were then manufactured and tested by Microla Optoelectronics. Each control board is equipped with an incoming RS422 interface and a regenerative output one. Firmware was developed in collaboration with Microla Optoelectronics. There were two different kind of firmware, low-level firmware and high-level firmware. The low-level firmware was developed for low-level commands of each board. High-level firmware was developed to control the entire cycle, and each functional phase, to start measurement sessions, report measures or errors, stop session.

A physical address is assigned to each board, via low-level firmware, to ensure mutual communication. The board always listens on the incoming RS422 channel and upon receipt of a command this is forwarded to the outgoing RS422 port to send the command just received on the following boards. The board in question is the only one enabled to reply and in response will send a status packet to indicate the status of its functions. The length of the command and status packages is always the same and equal to 20 bytes.

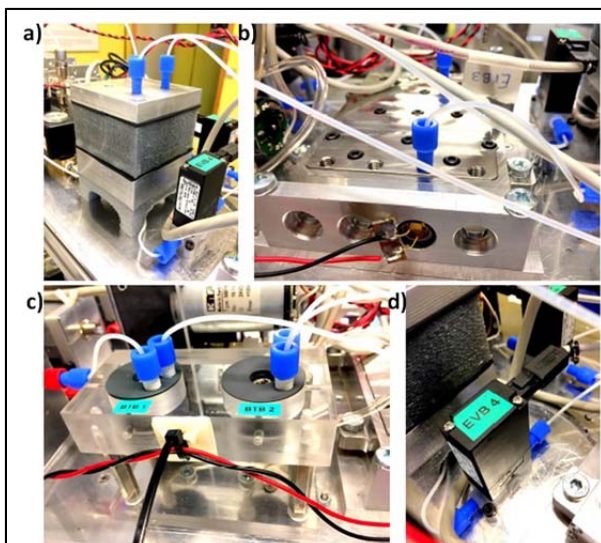

Figure 3: Fluidic elements which concur to dose, mixing and measurement phase. a) Mixing chamber, b) Measurement chamber, c) Bubble traps, d) Low-pressure valve

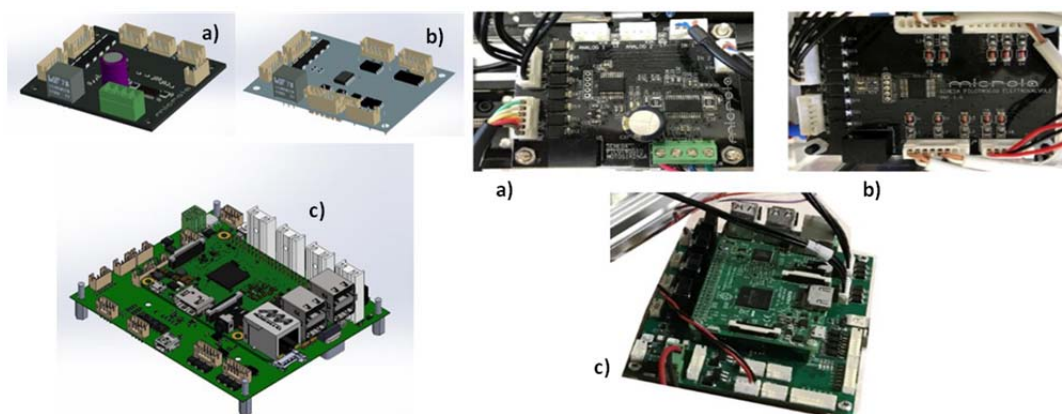

Figure 4: CAD renderings and realization of electronic boards: a) Moto-syringes board, b) valve board, c) motherboard.

The high-level firmware translates all the commands that each component of the system must perform during all the phases of the cycle, as previously discussed. This firmware, using the low-level firmware, marks the time of the various operations, activating the various components and synchronizing them together, in order to avoid errors in the cycle. The high-level firmware manages the quantities to be sampled, the pressures during the depressurization phase, the motion of the motor-syringes in the dosing and mixing phases, controls the laser diode in the measurement phase, interprets the signal coming from the detector, converting it first into absorbance and then, using the calibration curve, in measured concentration.

2.5 Method validation

The whole components separately designed were finally embedded in the portable case, interfaced with the software system. (Figure 5) The as mounted device was validated for Cr (VI) detection obtaining the accurate and automated collection of environmental data with less erroneous noise amongst the accurately recorded information. A measurement resolution and minimum threshold of 5ppb, for metal ions concentrations till 100 ppb, and a standard deviation of 0.64 ppb were obtained, in good agreement with the law established limits. Moreover, due to the fastness of the measurement and to the low volumes needed, many data can be collected in short time and with cost effectiveness.

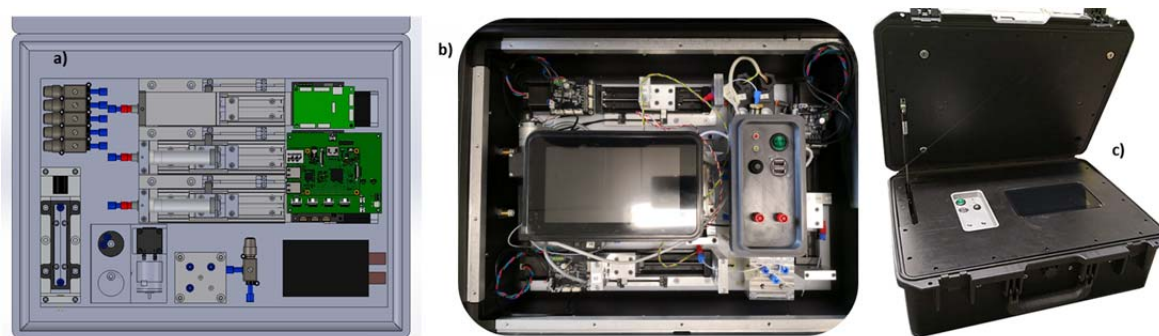

Figure 5: Portable device for Cr(VI) detection. a) Inside layout designed by Solidworks, b) Embedding in the portable carrying case, c) Final portable case.

3. Conclusions

In this study, a new system for monitoring pollutants dissolved in water has been studied. A miniaturized laboratory has been validated to work on-site in a completely autonomous way, that is, without the presence of an operator, performing the normal measurement operations that are currently performed in the laboratory, but on-field. At first, Cr(VI) was considered as target pollutant, detected by spectrophotometry.

The analysis of aqueous samples was carried out in a completely automated manner by the automatic device: in the sampling phase, in the sample preparation phase by means of reagents, in the colorimetric measurement phase and finally in the discharge or conservation phase of the complexed sample.

Due to the high linearity, repeatability and stability of the measurement, the miniaturized laboratory was successfully embedded in a portable case, as a monitoring tool for wastewater, groundwater and surface water, completely modifying the current water monitoring landscape. In this way, polluted areas can be mapped in a timely manner, without waiting for the measurement times in the laboratory, with the possibility of correlating any anomalies to possible causes immediately.

Last but not least, thanks to the reduced volumes involved, it is possible to use limited quantities of reagents. This entails a high cost efficiency, which allows to considerably increase the quantity of measurements and therefore the availability of data to be catalogued and shared in cloud, fundamental feature from an IoT perspective.

In a previous research (Periolatto et al., 2019) a similar device for Cr(VI) detection was mounted on an AUV equipped with wireless control and data transfer. Preliminary test on the field were carried out in Mediterranean sea, near Genova commercial port (Italy), obtaining promising results in terms of sample managing and online collection of results. Similar test are planned for the portable device and analogous results are expected.

Acknowledgements

This paper has been possible thanks to the sponsorship of the Italian Ministry of Economic Development's, General Directorate General for Safety - National Mining, Office for Hydrocarbons and Georesources.

Authors acknowledge Microla Optoelectronics S.r.l. (Chivasso, Italy), in particular Ing. Massimiliano Messere and Ing. Andrea Piscitelli, and Chemifin S.r.l. (Brescia, Italy) for the technical support and the interest on field applications of the study.

References

- Periolatto M., Catania F., Scaltrito L., Pirri C., Cocuzza M., Ferrero S., 2019, Continuous, on Site Spectrophotometric Determination of Zinc ions in Water Laboratory test preliminary to microfluidic device prototyping, Proceedings of Eighth International Conference on Advances in Bio-Informatics, Bio-Technology and Environmental Engineering ABBE, 16-22 DOI: 10.15224/978-1-63248-167-2-03
- Shtepluk I., Vagin M., Iakimov T., Yakimova R., 2019, Fundamentals of Environmental Monitoring of Heavy Metals Using Graphene, Chemical Engineering Transactions, 73, 7-12 DOI:10.3303/CET1973002
- Tundisi J.G., Matsumura-Tundisi T., Ciminelli V. S., and Barbosa F. A., 2015, Water availability, water quality water governance: The future ahead, IAHS-AISH Proc. Reports, 366, 75-79.
- Wang X., Yang F., Chen X., and Yang S., 2017, Environmental Chemistry of Toxic Heavy Metals Hg-As in the Jialing River, Chemical Engineering Transactions, 59, 883-888.