

The Structural Effects of Micro-Geometry on Masonry Vaults

Original

The Structural Effects of Micro-Geometry on Masonry Vaults / Alforno, M.; Venuti, F.; Monaco, A.. - In: NEXUS NETWORK JOURNAL. - ISSN 1590-5896. - ELETTRONICO. - 22:(2020), pp. 1237-1258. [[10.1007/s00004-020-00499-9](https://doi.org/10.1007/s00004-020-00499-9)]

Availability:

This version is available at: 11583/2841803 since: 2022-01-13T16:11:37Z

Publisher:

Springer

Published

DOI:[10.1007/s00004-020-00499-9](https://doi.org/10.1007/s00004-020-00499-9)

Terms of use:

This article is made available under terms and conditions as specified in the corresponding bibliographic description in the repository

Publisher copyright

Springer postprint/Author's Accepted Manuscript

This version of the article has been accepted for publication, after peer review (when applicable) and is subject to Springer Nature's AM terms of use, but is not the Version of Record and does not reflect post-acceptance improvements, or any corrections. The Version of Record is available online at: <http://dx.doi.org/10.1007/s00004-020-00499-9>

(Article begins on next page)

The Structural Effects of Micro-Geometry on Masonry Vaults

Marco Alforno, Fiammetta Venuti, Alessia Monaco

Politecnico di Torino, Dept. Architecture and Design
Viale Mattioli, 39, 10125 Torino, Italy

e-mail: marco.alforno@polito.it, fiammetta.venuti@polito.it, alessia.monaco@polito.it

Abstract.

Masonry vaults are able to withstand their dead load and external forces thanks to their curved surface, therefore geometry plays a major role in their structural behaviour. Besides the well-known effects of the macro-geometry (overall shape and dimensions), micro-geometry (details of the masonry apparatus) is also expected to play a key role. The study seeks to determine the advantages (constructional and structural) that a specific masonry apparatus offered for simple forms like barrel vaults and more complex forms like cross vaults. It is carried out, firstly, through a critical review of the European technical literature concerning vault construction with particular focus on brick laying techniques; then, numerical approach is adopted to scientifically investigate the role of micro-geometry on the static behaviour of barrel and cross vaults subjected to self-weight. Comparison of results allows observing different structural behaviour (displacement field, elastic stiffness, reaction forces) for different brick patterns and provides a scientific validation to some speculations found in historical technical literature.

Keywords: masonry vaults; brick pattern; micro-geometry; structural behaviour, numerical modelling.

1. Introduction

Masonry vaults represent one of the most widely used structural elements in historical constructions. Vaults belong to the family of so-called form-resistant structures, meaning that they are able to withstand their dead load and external forces thanks to their curved surface. Hence, geometry plays a major role in the structural behaviour of this kind of structures.

For the aim of the present work, a distinction will be made between macro- and micro-geometry. With *macro-geometry* we denote the overall dimensions of the vault (dimensions in plan, rise-to-span ratio) and its geometrical configuration (e.g., barrel, cross, pavilion, etc.). The same macro-geometry can be built with different materials (stone, bricks) and with different patterns of the masonry apparatus. These features denote what we call *micro-geometry* and are mainly related to the historical building practice relative to a specific age and geographic area. For instance, in Italy in the sixteenth to nineteenth centuries brick vaults were much more popular than stone vaults: their success was due to the fact that bricks are

much lighter than stones, much easier to handle, and adaptable to any kind of form and pattern in relation to the functional and structural necessities (De Cesaris 1996). While the structural effects of macro-geometry have been extensively investigated (e.g., Huerta 2004), the role of micro-geometry on the structural behaviour of vaults is addressed far less often in the structural engineering literature, with a few exceptions (Baratta and Corbi 2003; Barbieri et al. 2004; Calderini and Lagomarsino 2004; Foraboschi 2014, Alforno et al. 2019).

Actually, great attention to brick laying and the creation of the masonry apparatus can be found in the European technical literature published between the seventeenth and the nineteenth centuries (Lassaulx 1829; Breymann 1849; Curioni 1870; Choisy 1883), which has deeply dealt with the constructive phases of vaults. This careful description of brick laying best practices probably highlights the desire to increase the strength of brick vaults, also through the building techniques, namely brick laying and the orientation of the joints. As a matter of fact, in masonry vaults brick pattern played a key role, both in terms of construction feasibility and expected structural performance. Nonetheless, this crucial role could not have been investigated with the scientific knowledge available in the past.

The aim of this study is to scientifically investigate the role of micro-geometry, i.e., of brick pattern, on the static behaviour of barrel and cross vaults. Nowadays, we can rely on different modelling strategies to simulate the structural behaviour of masonry structures. Within the framework of the finite element method (FEM), two modelling approaches can be adopted (Lourenco et al. 1995): 1) a macro-modelling approach, where the different elements constituting masonry (i.e., bricks and mortar) are “smeared” into a homogeneous continuum material; 2) a micro-modelling approach, where each masonry constituent is separately modelled, as are the interfaces between bricks and mortar. The second approach, in its simplified version (Lourenco et al. 1995), will be adopted in this study.

Sect. 2 of the paper is devoted to a comprehensive review and critical reading of the European technical literature concerning barrel and cross vault construction techniques. In Sect. 3, a numerical investigation is carried out on two ideal vault geometries (barrel and cross) arranged with different brick patterns and subject to dead load only, in order to highlight the influence of the masonry apparatus on their static behaviour and to provide a scientific validation to some speculations found in historical technical literature.

2. Vault Construction Techniques in the European Technical Literature

2.1. Barrel vaults

Since the fifteenth century the technical literature considered the construction techniques that allow for the construction of vaults to be identical to the one used for the construction of walls (Curioni 1870). However, even if the materials are the same as in masonry walls, bed joints in vaults are curved, and all the head joints point to the center of their arch. For barrel vaults, bricks could be laid according to four main patterns: longitudinal or radial, with bed joints parallel to the abutments; transversal (pitched or vertical), where bed joints are perpendicular to the abutments; oblique or diagonal, with bed joints pointing to the center of the vault; herringbone (De Cesaris 1996). The oblique pattern can also be intended as inverse-oblique (bed joints perpendicular to the bisector of the angle) and in some geographic and historical context bricks could be laid “in folio” (face-down), creating “tile vaults”, also

known as *volte in folio* or *boveda tabicada*, usually seen with herringbone pattern or oblique pattern.

The most common method of building vaults consisted in using the longitudinal pattern, namely placing the bricks radially, like the voussoir of an arch (Fig. 1). This way of building vaults is the natural evolution of the technique used for building arches, therefore is the most widespread throughout history. When bricks were used instead of cut stone, they were clearly meant to act as voussoir even when they did not take a wedge-shaped form and, in order to follow the curvature of the surface with parallelepipeds, it was sufficient to make wedge-shaped mortar joints. Wedge-shaped bricks were sometimes used by the Romans in the construction of perfectly circular arches in order to reduce to a minimum the thickness of the bed joints and provide added strength.

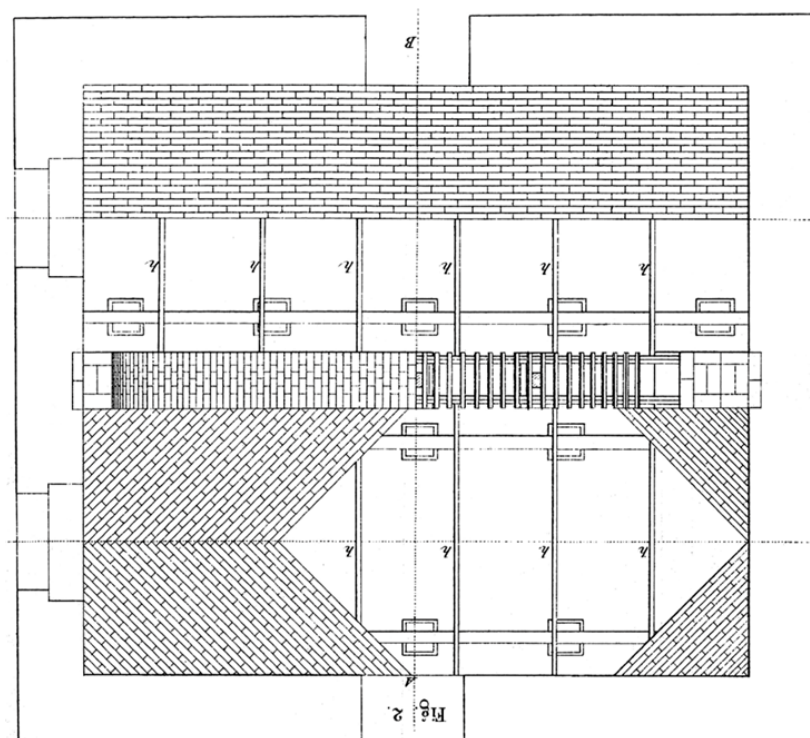

Fig. 1 Brick patterns in barrel vaults in Breymann (1849, Vol I, Plate 37, Figure 2): radial (top) and oblique (bottom)

This construction technique required the use of formwork to support the vault until the crown row was put in place, just like arches. The brick laying was carried out by setting the bricks perpendicular to the intrados arch on the wooden formwork. Once the construction of one longitudinal row was completed, it was possible to continue with the consecutive row, symmetrically, until reaching the crown row, which was shaped as a wedge, if needed. The planes of the head joints have to be normal to the intrados and interleaved with regard to the previous and successive row of blocks, so as to avoid a continuous joint and provide good interlocking (Chevalley 1924).

In the technical literature great attention is given to the description of the wooden centerings, which had to be carefully designed in order to be able to withstand the weight of the vault until completion and act as a geometrical guide. This was possibly the most crucial phase of all, because these wooden structures were not supposed to deform excessively under the growing weight of the superimposed vault, otherwise its final geometry would have suffered from this distortion (Valadier 1992). Therefore, wood centerings had to be carefully designed and built taking into consideration that, with the use of this brick pattern, they had to withstand the entire weight of the vault until the very last row of bricks was put in place, since the vault was not able to find any equilibrium paths before that moment.

In some cases, the construction of wood formwork was difficult, if not impossible: the retrieval of wood was an additional issue for large vaults and domes, especially in some geographical areas where wood was scarce. To overcome these problems, self-supporting structures were invented, namely vaults able to find equilibrium during their whole construction process, hence did not need formwork: the most famous example is certainly the Brunelleschi's Dome of Santa Maria del Fiore in Florence (Cantalupi 1867).

The possibility of constructing without formwork is strictly correlated to the internal micro-geometry of the masonry apparatus, since only specific building techniques allowed for construction without supports. One of the oldest methods was called pitched brick vaulting. It is an adaptation, developed in the first century of the Roman Empire, of a much older Near Eastern and Egyptian technique that was used in mud brick architecture from at least the third millennium BCE (van Beek 1987). The term 'pitched' derives from the fact that the first ring of bricks was not placed vertically, but at an angle against the end wall or against an arch constructed previously at the extremity of the barrel vault (Fig. 2). The creation of a non-vertical plane, perpendicular to the axis of the vault, allowed for the construction of subsequent brick courses without the use of formwork: bricks were "glued" to the previous rings by using fast setting mortar and, once a ring was completed, it became stable by form (Besenval 1984; Choisy 1883; Fathy 1973). The pitched vaulting technique had some variations, as described by Choisy: with plane leaning arches (Fig. 2a), with curved arches (Fig. 2b), with conical joints and vertical arches (Fig. 2c) and with conical joints and leaning arches (Fig. 2d).

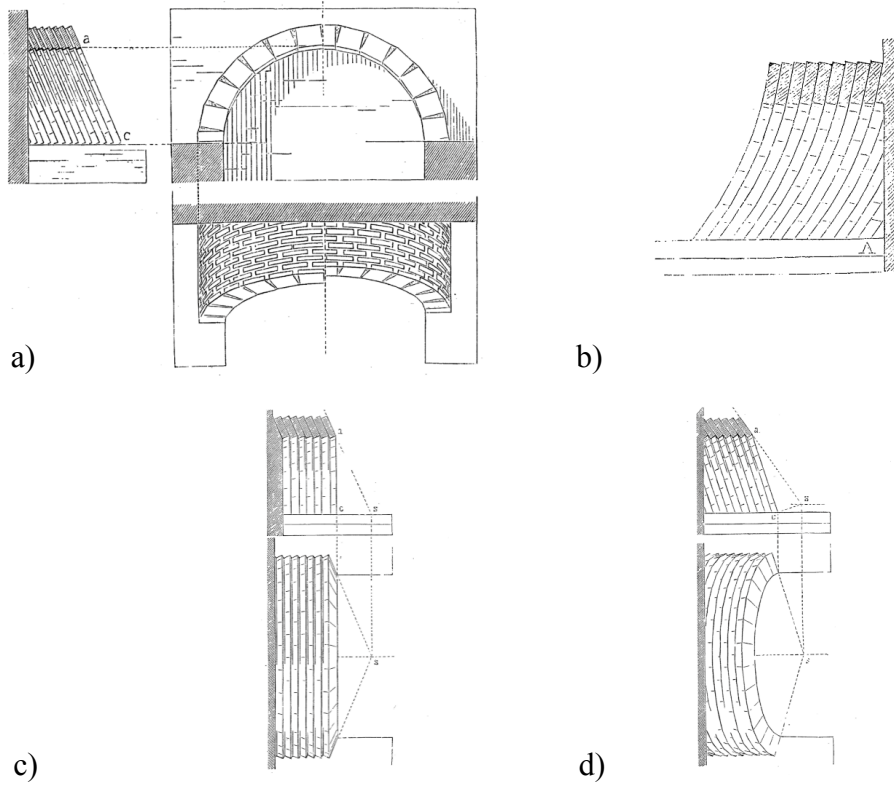

Fig. 2 Pitched mud brick vault after Choisy (1883): a) plane leaning arches (p. 33, Fig. 31); b) curved arches (p. 34, Fig. 33); c) conical joints on vertical arches (p. 35, Fig. 34); d) conical joints on leaning arches (p. 35, Fig. 35)

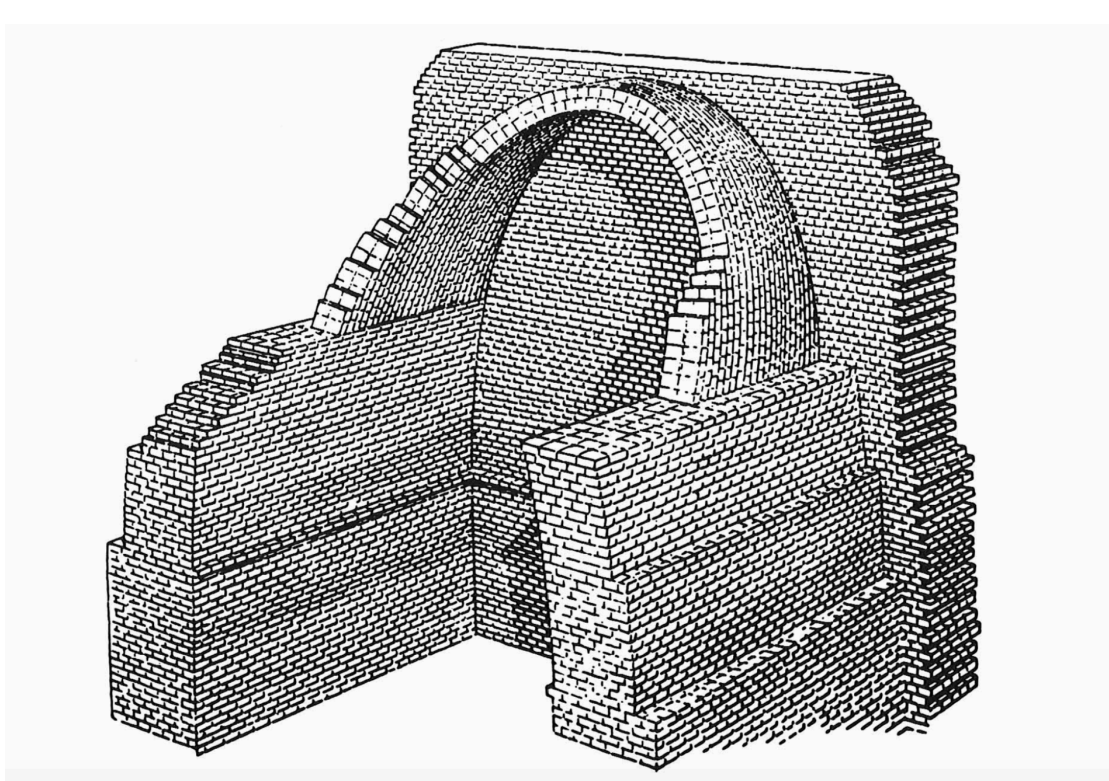

Fig. 3 Construction technique of a pitched vault after Reuther (1938)

Figure 3 shows an example of the construction of an Egyptian pitched vault. It is interesting to see that in these Middle-Eastern pitched vaults the elongated arch form offered structural advantages of which builders must have been generally aware. Their shape is optimized according to a catenary, which – as stated by Robert Hooke – is the ideal shape of an arch capable to carry loads only in compression when subjected to self-weight. The principle is alleged in his famous statement “As hangs the flexible line, so but inverted will stand the rigid arch”. That is to say, if one takes a flexible chain and holds it by its ends, the shape that it will acquire is a catenary, since the chain is able to work only in tension. If we were to freeze this shape and flip it upright, we would obtain an arch capable of carrying loads only in compression. The catenary shape is the optimized shape only if the vault does not carry any additional weight, such as infill or superimposed loads. Otherwise, the funicular shape will shift from a catenary to another funicular shape. According to Oscar Reuther (1938), Middle Eastern builders derived this geometry from the construction process, rather than having any theoretical basis. Therefore, the optimized catenary shape was probably the most stable configuration when constructing subsequent brick courses. This method developed in areas where wood was scarce because it provided a way of building vaults without using a wooden centering structure (Lancaster 2015). These elongated arch forms were not imported in Europe and rarely appear outside of Egypt.

This technique was largely used for the construction of barrel vaults until modern times, but it was slightly modified not only with regard to the geometry of the vaults (to the Romans the catenary-shaped arch was not as pleasing as the semi-circular arch) but also with regards to the construction process and micro-geometry (brick arrangement). As a matter of fact, the terms “pitched” is improperly used when referring to European vaults. As pointed out by Lynne Lancaster (2015), in Roman barrel vaults the bricks are set vertically and the fact that the same term has been used to describe both the vertical and pitched vaults has obscured an important distinction that provides clues regarding the transmission of the technique (Fig. 4). It has also led to the assumption that both methods were used for the same reason, which may not be true. While in the Near East the scarcity of wood may justify the use of pitched vaults, in the European tradition we can see that vertical bricks are most often used only at the crown of the vaults. The reason for using vertical bricks at the crown of the vault when the haunches are built of radial bricks is not always clear. Choisy, in his monograph on Byzantine construction (Choisy 1883), speculates that haunches were built of radial bricks without centering until the point where this was no longer possible and then the vault was completed with vertical bricks.

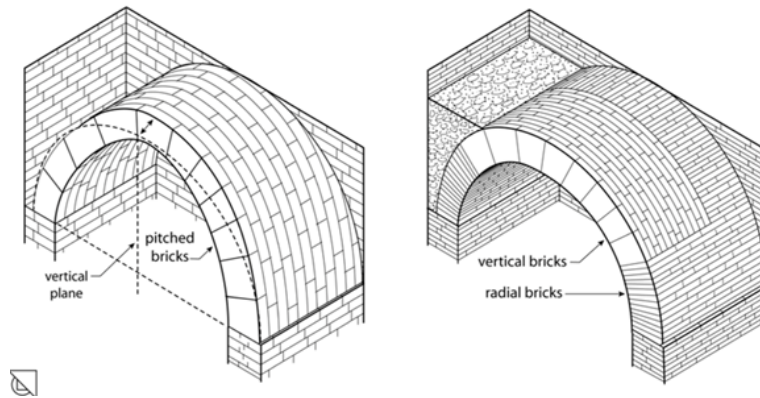

Fig. 4 Scheme of pitched and vertical/radial brick pattern after Lancaster (2015)

Lancaster also explains that in some Roman vaults it is possible to see centering holes and that the radially laid bricks extend too far to have been built without any supporting structure, suggesting that they were built using formwork despite the use of this brick pattern. The choice of vertical bricks, even if formwork was used, can be explained considering that, once every new course was closed, it began to act as an arch, therefore relieving the formwork below from part of the vault's weight. This could have resulted in a smaller and cheaper wood structure. Moreover, since every new course was self-supporting, it was possible to build the vault in sections, reusing the same formwork for subsequent sections. One further consideration in choosing vertical bricks for the crown could relate to the builder's perception of some structural advantage. As a matter of fact, the crown of a vault (or an arch) is the first place where visible cracks appear. As can be seen from Fig. 5, the classic crack pattern consists in two hinges at the intrados (therefore not visible from underneath) and one at the extrados (i.e., at the crown). Builders observing this behaviour would have naturally perceived the crown as a weak point. In fact, the formation of the three hinges is a completely physiological process for arches and vaults, and it is safe as long as the abutments do not spread substantially and a fourth hinge opens, allowing for the formation of a kinematically admissible mechanism that will lead to the collapse of the structure. However, it is understandable that visible cracks may raise some concerns regardless of the inherent stability of the structure, and the builders may have wanted to prevent them. In traditional radial brick vaults, bed joints run along the length of the crown and form natural lines of separation, whereas in vertical brick vaults the head joints of subsequent parallel arches are interleaved, providing good interlocking. Therefore, cracks at the crown would have to cross through both brick and mortar, rather than forming within a single mortar joint. Since bricks have greater tensile strength than mortar, vertical bricks could have provided some additional resistance to tensile stresses. Choisy already noted this behaviour and explained that this type of construction resulted in vaults that did not produce lateral thrust (Choisy 1883). We know that this is not the case, as it will be discussed later. However, it is interesting to note that, from Roman builders and possibly to modern ones, the choice of this brick pattern was made not only for construction reasons, but also for structural ones.

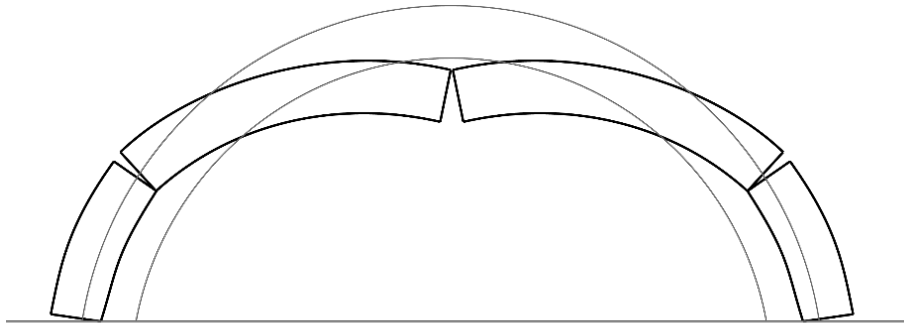

Fig. 5 Three-hinge mechanism of a masonry arch

For lower rise-to-span ratios, joints close to the spring lines are almost vertical and parallel to each other. In those cases, a pattern with diagonal courses was preferred. Bricks were laid at a 45° angle with respect to the plan of the vault, starting from the four corners and simultaneously heading to the center, and in the ridge of the vault they are connected in a seam. Even though the bed joints are rectilinear in plan, they describe arches on elliptical directrix that match on the axes of symmetry of the vault. Builders believed that these arches generated some horizontal thrust both on the abutments of the vaults and the head walls, perpendicular to the longitudinal walls. This can probably be considered as an attempt to divert the horizontal thrust of the structure to the transversal walls, in order to reduce the stresses on the longitudinal walls. This solution is, in fact, rather common in European vaults and is often shown also in the manuals (Fig. 1, bottom). However, it is worth noting that in common practice builders not always build vaults in contact with the end walls, making the employment of this brick pattern useless.

Bricks needed to be shaped properly in order to build arches on cylindrical surfaces with a rectilinear projection. An alternative method, used particularly in low height vaults provided with head walls, consisted in disposing bricks at a 45° angle, starting from the crown with bed-joints pointing at the corners of the vault. This pattern, sometimes called “inverted oblique”, was convenient for vaults not meant to be covered in plasterwork, thanks to its regularity of construction. While the curvature assures the stability of each fresh course, the use of formwork could be avoided and, contrary to the Middle Eastern pitched vaults, the courses are shorter, thus reducing the risk that fresh ones will buckle and reducing the pressure on the head joints, which is a considerable advantage when using regular lime mortar instead of a fast setting one.

2.2. Cross vaults

According to common practice, in European cross vaults the direction of the courses varies from radial to diagonal. In the case of radial courses, a formwork is required, just like in the case of a barrel vault with the same pattern or in the case of an arch (not stable until the key stone is positioned). When this pattern is used, good interlocking should be provided at the intersection of the caps, in order to strengthen the groins and prevent cracking along these lines.

Cross vaults can also be built entirely without any formwork or centering, in a procedure that is once again based on pitched bricks and consists of the intersection of four barrel vaults

with transversal, almost vertical, arched courses that are built simultaneously starting from the four surrounding walls. As shown in Fig. 6 the arched courses are inclined and the intersection at the groins can occur, as in the case of the radial pattern, by interlocking subsequent courses along the groin lines.

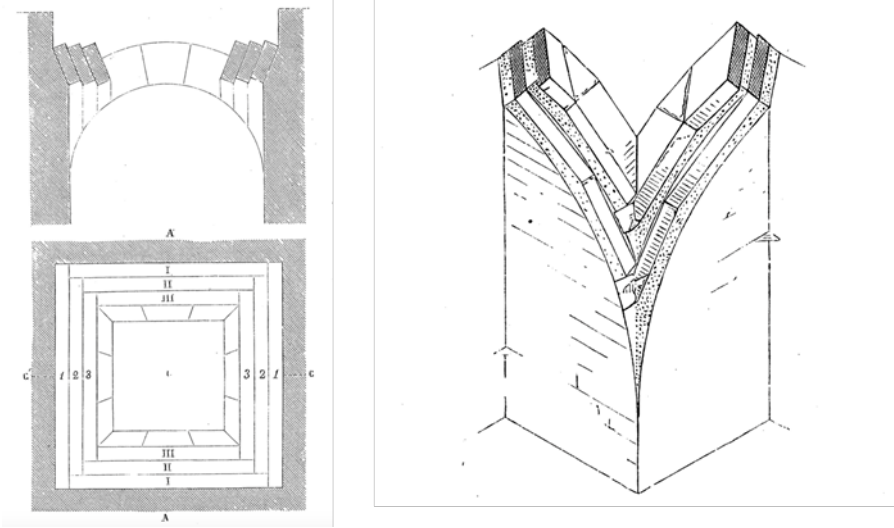

Fig 6 Pitched brick laying after Choisy (1883, p. 51, Fig. 55)

Florencio Ger y Lobez (1869) describes this construction method as common in Extremadura, Spain, and states that it can be facilitated by avoiding the intersection of pitched courses along the groin lines, as shown in Fig. 7. This could be done by positioning corbelled horizontal bricks at the groins until this is no longer possible, and then stabilizing them by laying arched courses on their back parts, so as to prevent overturning. This process is repeated until the area close to the crown is reached, where arched courses can intersect more easily at the groins without the need of horizontal corbelled bricks. According to David Wendland (2007), in the European tradition (apart from the regional tradition in Extremadura, Spain), pitched cross vaults with vertical arched courses do not occur, but were almost exclusively confined to the East.

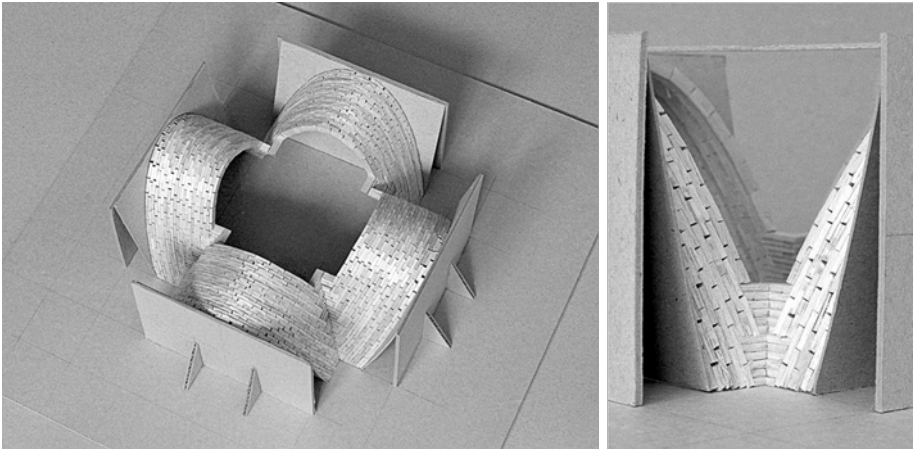

Fig 7 Model of pitched cross vault after Wendland (2007)

One extremely rare example of this building technique found in northern Italy is the Palazzo della Pilotta in Parma, built during the sixteenth century. In Fig. 8 it is possible to note the inclination of the arched courses as well as the corbelled horizontal bricks at the groins.



Fig 8 Pitched cross vaults in Palazzo della Pilotta, Parma, Italy: left) General view; right) detail of the corbelled bricks along the diagonal arches. Photo: Marco Alforno

A rather common masonry apparatus in European cross vaults of brick masonry consists in arranging the courses on diagonally tilted planes perpendicular to the groins. However, the use of this pattern requires highly skilled masons because the brick courses have to be shaped correctly at the seams on every cap, as well as along the groins. With this pattern, a continuous masonry fabric is created through the neighbouring caps over the groins, thus avoiding a continuous joint along the diagonal arches. The diagonally tilted courses are seamed in the ridge of every cap. In this pattern, every new brick course is self-supporting with an arch-like curvature, as described in the previous paragraphs. However, in contrast to barrel vaults with the same diagonal pattern, cross vaults cannot be built without any provisional support at all when using this pattern: as a matter of fact, wood centering is required in order to support the diagonal arches during construction, whereas the rest of the surfaces can be built arranging self-supporting courses to be spanned conveniently between the centering arches.

The spatial position of the bed-joint planes is supposed to be normal to the curve of the groin. However, this rule leads to a radial inclination of the bed joints and consequently to an angle of every bed-joint plane with respect to the preceding one. Such an arrangement is usually described in the building manuals, as can be seen in Fig. 9, where bed joint planes are sketched perpendicular to the diagonal arches.

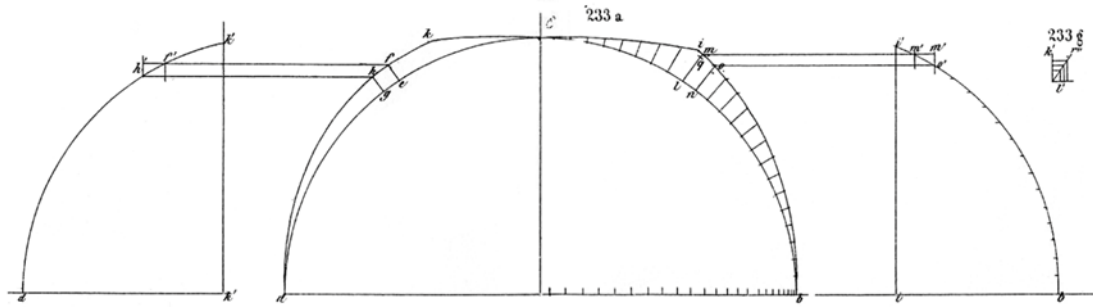

Fig 9 Disposition of bed joint planes according to Georg Ungewitter (1859: Plate 8)

In common practice, when the caps are built without using a formwork, all the blocks of the same arched course are aligned on a single plane; therefore every new course generates an arch on a plane and all the subsequent courses are parallel to each other. In doing so, bed joint planes are not always perpendicular to the curve of the groin. However, if the planes were at an angle to each other in order to always be normal to the groin line, the bed joint thickness would not be constant (Fig. 10). This would obviously not be feasible in practice and would also affect the structural behaviour of the vault.

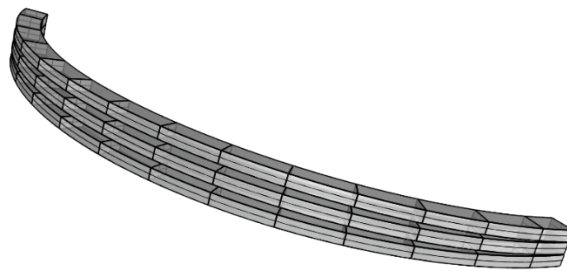

Fig 10 Variation of the thickness of the bed joints in the case of courses planes normal to the groins

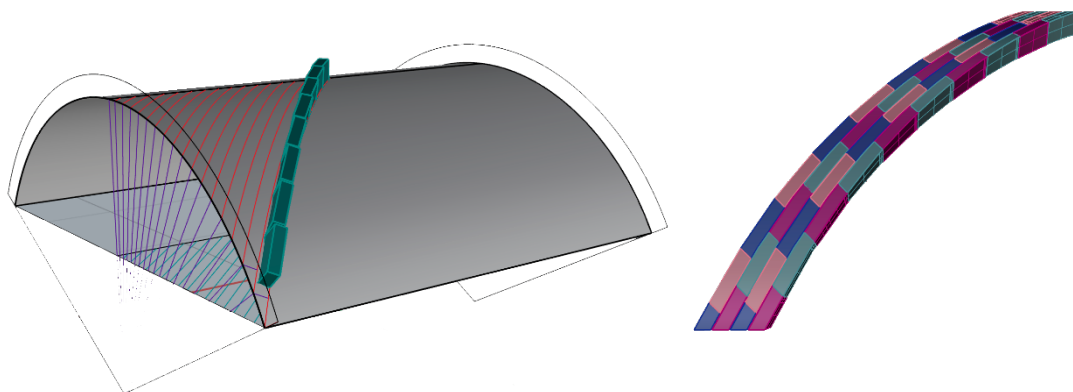

Fig 11 Rhino model of a diagonal brick course on a curved intrados surface

If a formwork is used, even when building with a diagonal pattern, blocks can be arranged so that each of them is perpendicular to the intrados surface (formwork surface). In doing so, bed joints of every block will be normal to the surface of the formwork and of constant thickness. However, they will not be on a plane, but on a doubly curved surface (Fig. 11). This solution guarantees good geometric control of the intrados surface since every brick is nestled on the formwork surface. Moreover, constant thickness of the mortar joints is provided which, as stated by Rondelet (1831), have a relevant role for any kind of vault: a good and regular joint can increase significantly the behaviour of the structure.

3. Numerical Simulations

3.1. Modelling approach

In what follows we will introduce the numerical simulations performed on ideal geometries of barrel and cross vaults that have been discretized according to some of the above mentioned brick patterns. The chosen modelling approach relies on the FEM framework and consists in a simplified micro-modelling approach. The structure is assumed to be made of expanded masonry units (bricks + mortar joints), which are assumed to be deformable with linear elastic behaviour. Each unit has the dimension of the brick increased by the mortar thickness. The interface behaviour between the block faces in contact is modelled using the constitutive law that follows Coulomb's classic friction failure criterion, under the simplified hypothesis that the shear stresses are null for normal stresses equal to zero. This assumption is quite realistic for dry joints and can be considered a good approximation even for mortar joints made of low-cohesive material. Finally, all analyses are performed taking into account the geometrical nonlinearities.

3.2. Description of the case studies

The chosen case studies include two macro-geometries: a simple vault geometry such as a barrel vault, and a more complex form such as a cross vault. The barrel vault has a rectangular base: the net span of the arch is approximately 3.1 m, the rise is about 1.175 m, and the length of the vault is 5.30 m. Three patterns were modelled: radial bricks, diagonal bricks and vertical bricks (Fig. 12). The cross vault has a square base and is generated by the intersection of two semi-circular barrel vaults, with the same net span and rise as the previous one. Three patterns were modelled: radial bricks, vertical bricks and pitched bricks (Fig. 13). The discretization of the vault's geometry was performed with blocks of the size of typical bricks (6 x 12 x 24 cm) except for the blocks along the diagonal arches in the cross vaults and for the blocks along the seam in the ridge of the diagonal barrel vault, which were modified in order to simplify contact definition in the FEM environment. All the geometrical models have been generated with the modelling software Rhinoceros and subsequently imported in Abaqus for the generation of the structural models. The finite elements used for the bricks are linear hexahedra of 30 mm size, resulting in a maximum brick to element size ratio equal to 0.5. The blocks along the seam in the ridge of the diagonal barrel vault and along the diagonal arches and the abutments of the cross vault are modelled using second-order tetrahedra of the same approximate size. For the hexahedral elements the meshing technique is of structured type, while for the tetrahedra a free meshing algorithm has been adopted. For the blocks, the

following mechanical properties are assumed: material density $\rho = 1800 \text{ kg/m}^3$; elastic modulus $E = 1200 \text{ MPa}$; Poisson coefficient $\nu = 0.2$. Friction interfaces are characterized by a friction coefficient $\mu = 0.5$ and a compression stiffness $k_n = 5 \times 10^{10} \text{ N/m}^3$ to simulate perfectly rigid contact. Such parameters are those suggested in Rossi (2016) with the exception of k_n which has been calibrated by the authors.

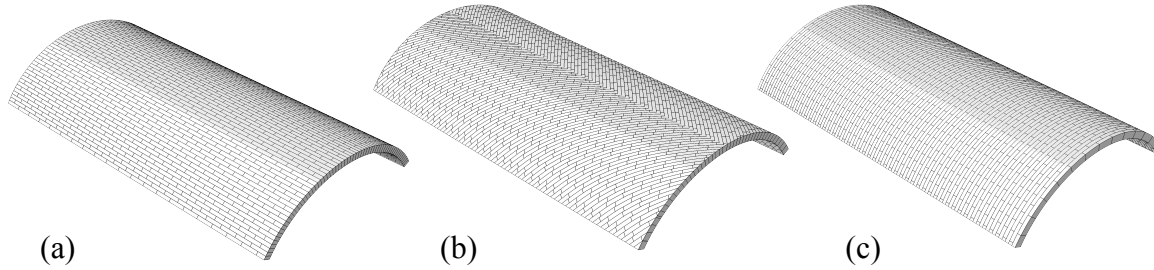

Fig 12 Discretization of the barrel vault model with three patterns: a) radial; b) diagonal; c) vertical

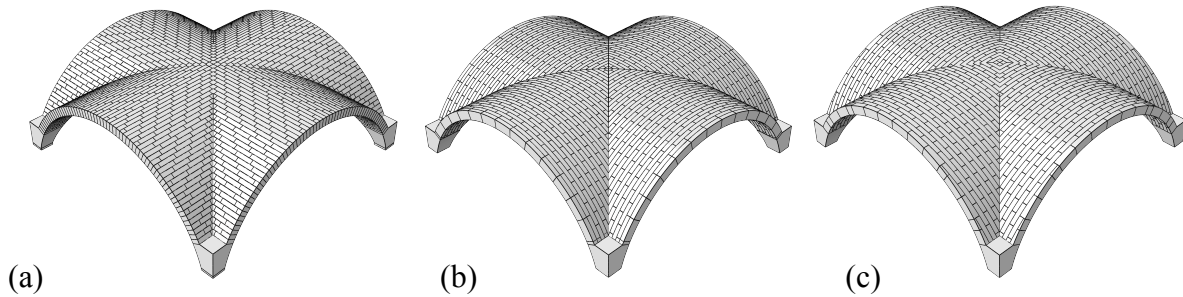

Fig 13 Discretization of the cross vault model with three patterns: a) radial; b) vertical; c) pitched

The analysis is performed in one step, over which gravitational acceleration is increased linearly in order to simulate self-weight. The numerical calculation procedure adopted is the dynamic implicit analysis with quasi-static loading. All nodes at the abutments are pinned, resulting in fixed supports. Moreover, in order to confine the head arches of each vault, vertical walls adjacent to the head arches are modelled as solid plates of 30 mm thickness, meshed with linear hexahedra of 30 mm size (Fig. 14). All nodes of the walls' outer surfaces are pinned, resulting in fixed elements. Contact between the blocks of head arches and walls is defined using the same interface behaviour adopted in the block-to-block contact definition. This means that normal compressive forces can arise, whereas no tension forces can develop. Shear forces along the planes of the walls can be generated, depending on the normal forces, according to a Mohr-Coulomb criterion.

Fig. 15 depict a schematic representation of the reaction forces that will be monitored in the various models. In the scheme, $R_{x_{abt}}$, $R_{y_{abt}}$ and $R_{z_{abt}}$ represent the sum of the horizontal (longitudinal and transversal) and vertical reaction forces along one spring line, whereas $R_{x_{head}}$, $R_{y_{head}}$ and $R_{z_{head}}$ represent the horizontal (perpendicular and parallel to the wall) and vertical reaction forces in one vertical head wall. Note that in the barrel vault $R_{y_{head}}$ is always null.

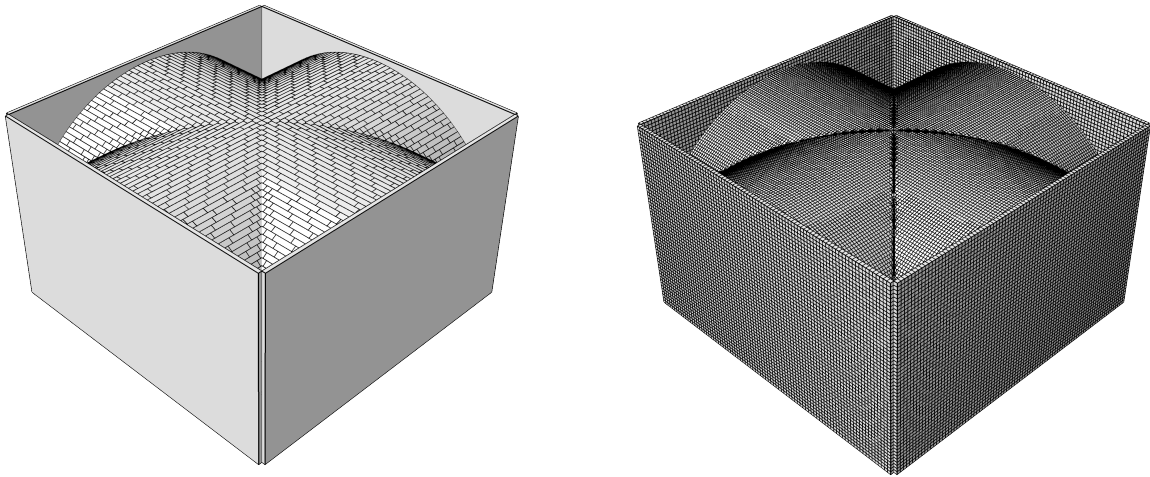

Fig 14 Geometrical model (left) and structural mesh (right) of a cross vaults with radial pattern and head walls

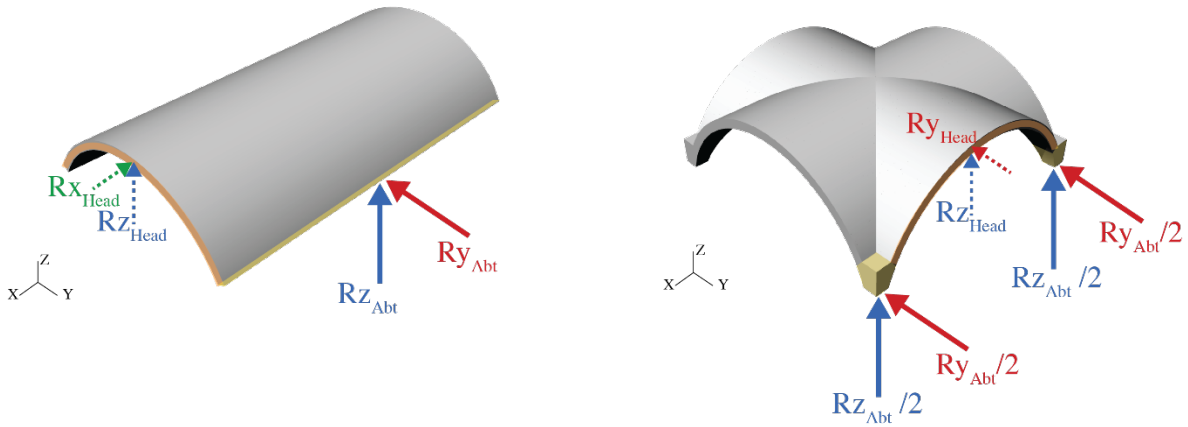

Fig 15 Schematic representation of boundary conditions applied to the models

3.3. Results

3.3.1. Barrel vaults

The static analyses performed on the three barrel vault models show that their structural response changes with different internal micro-geometries, even though the macro-geometry is the same. A first result that we can observe is related to the deformability of the structures. Figure 16 shows the of contour plots of vertical displacement under self-weight for the three barrel vaults: the maximum vertical displacement for all configurations is located at the crown of the vault and is equal to 7.2 mm in the case of radial bricks, 6.50 mm for diagonal bricks and 2.74 mm for vertical bricks. From these data, the radial brick configuration is the one that provides the greatest stiffness to the barrel vault. Furthermore, the distribution of vertical displacement along the longitudinal direction is almost constant in the vertical brick configuration, which means that this vault almost behaves as a two-dimensional system. This was expected and due to the fact that there is no interlocking between subsequent arches, in

contrast to the other two patterns. In fact, the interlocking in the longitudinal direction provided by the radial and diagonal patterns results in a more pronounced three-dimensional behaviour, as shown by the variable distribution of displacements along the longitudinal axis. It is worth noting that this distribution is asymmetrical in the case of the diagonal pattern.

In Fig. 17 the values of the reaction forces at one abutment and one head wall are plotted, normalized to the vault's self-weight, for each pattern (see Fig. 15) The vertical vault is the one that interacts the least with the adjacent transversal walls (having the lowest reaction at the head walls), contrary to the diagonal vault, which is the one that interacts the most. The vertical vault is the one that produces the greatest horizontal thrust at the abutment, contrary to some speculations found in the nineteenth-century treatises (Choisy 1883). The horizontal thrust perpendicular to the head walls is the greatest when a diagonal pattern is used, being three times greater than with a vertical pattern and more than five times than with a radial pattern. This results in a reduction of the horizontal thrust at the abutments ($R_{y_{abt}}$), which with this pattern is almost 25% less than in vertical brick vaults.

Figure 18 plots the distribution of thrust forces along the supports. The thrust distribution is almost constant in vertical and radial brick vaults, but in the latter the zones close to the head walls experience a greater reduction of thrust forces than in the former. This is in agreement with what has been observed in Fig. 16 and Fig. 17. In contrast, the diagonal vault experiences a non-constant thrust distribution along the abutments.

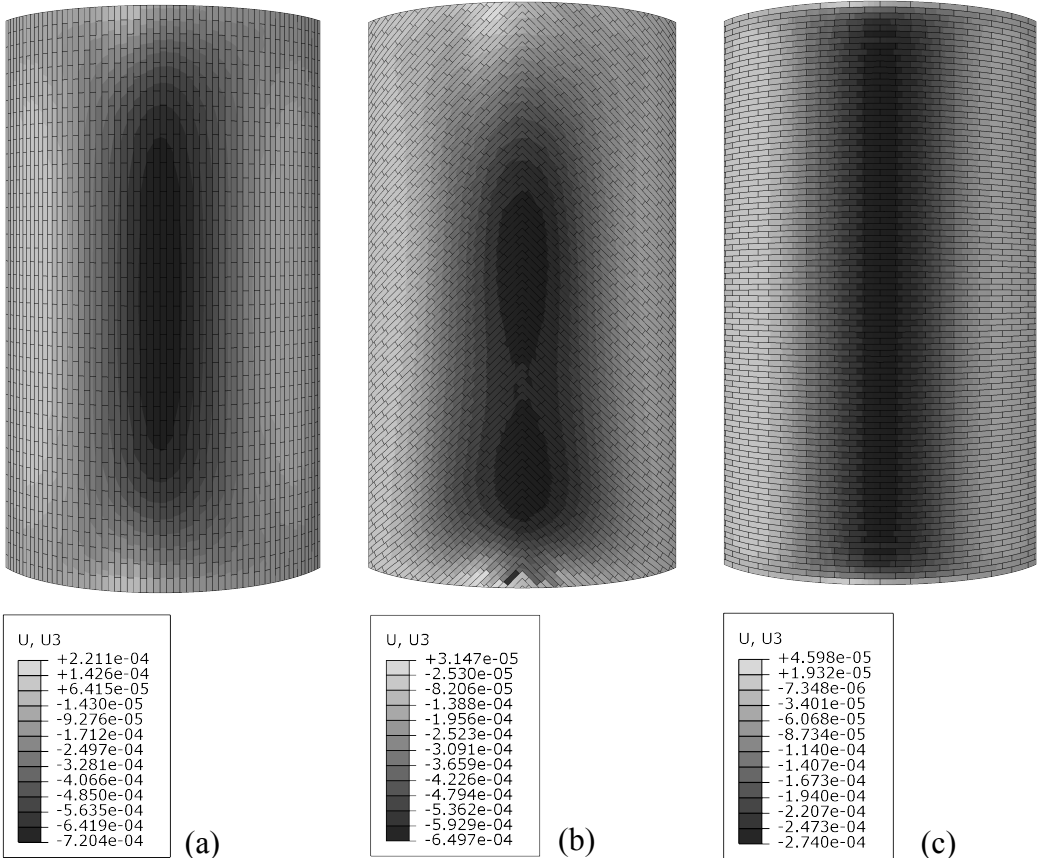

Fig 16 Vertical displacement [m] in barrel vaults with a) radial pattern, b) diagonal pattern, c) vertical pattern

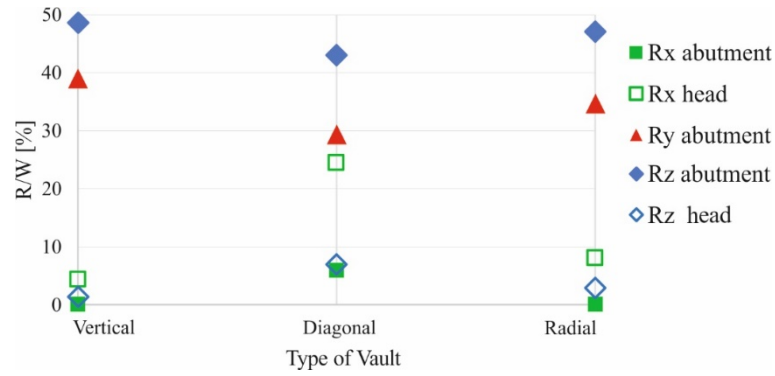

Fig 17 Barrel vaults reaction forces

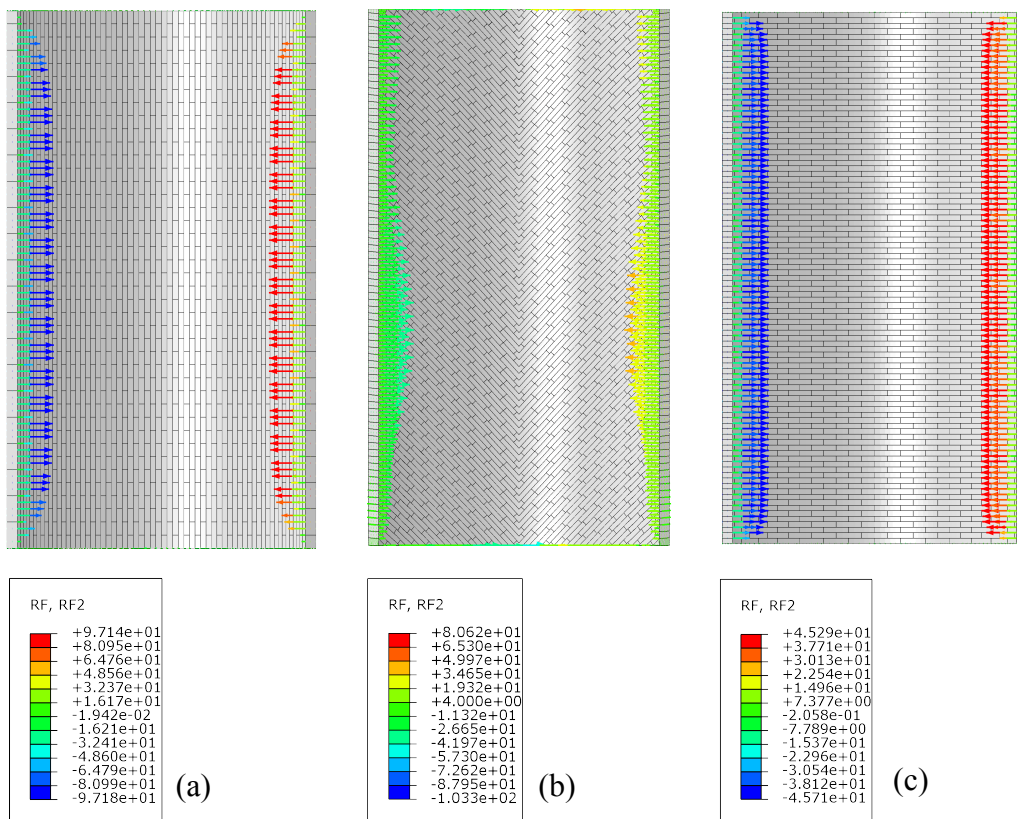

Fig 18 Horizontal reaction forces [N] along the abutments in a) radial, b) diagonal, c) vertical barrel vaults

3.3.2. Cross vaults

In the case of cross vaults, both vertical and pitched patterns were analyzed, even though the vertical pattern is not reported in the technical treaties and cannot be found in built examples of cross vaults. The numerical simulation of a cross vault with vertical pattern actually shows that this type of brick laying does not allow for equilibrium in cross vaults. As a matter of fact, the vertical arches are stable only until they can be supported by the abutments, and the courses that are not directly in contact with the supports slide vertically (Fig. 19).

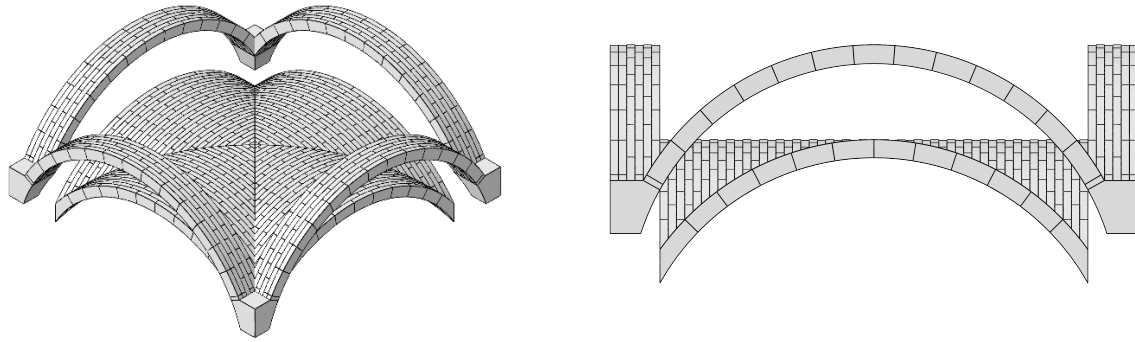

Fig 19 Sliding mechanism occurring in a vertical cross vault under self-weight

The pitched pattern was then analyzed, consisting in slightly non-vertical parallel arched courses, as seen in Fig 8. This building technique, used in barrel vault construction to build without the use of formwork, as previously discussed, plays a crucial structural role in the case of cross vaults. The non-vertical planes of the arches, specular with respect to the symmetry axes of the vault, prevent the arched courses from sliding downward. However, this masonry apparatus can allow for equilibrium only if head walls can withstand the thrust generated by the vault along the head arches. In order to evaluate the vault's capability to find equilibrium with pitched bricks and to study the role of head walls, two tests were performed in the numerical model: with and without head walls. Figure 20 plots the deformed shape of the cross vault under self-weight with the two different boundary conditions. It emerges that this masonry apparatus allows for equilibrium under self-weight only if the vault is confined by head walls. Otherwise a sliding mechanism, similar to the one described in the vertical pattern, occurs.

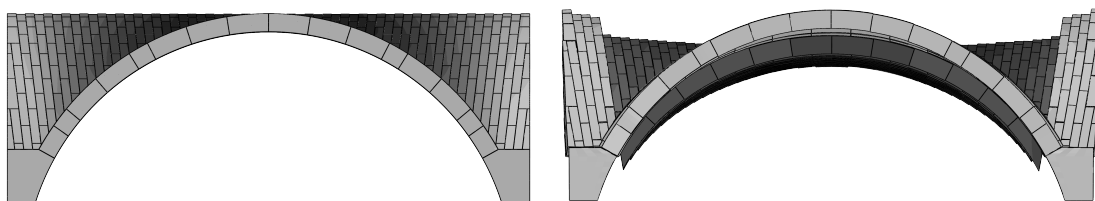

Fig 20 Pitched cross vault with head walls (left) and without head walls (right) under self-weight

The same analyses were performed on the radial brick cross vault model. Contrary to the pitched cross vault, radial vault can find equilibrium even if head walls are removed. Comparison between deformed shapes, obtained in the confined (Fig 21, left) and non-confined configuration (Fig. 21, right), shows that head walls contribute to stiffening the system, avoiding the out-of-plane deformation of the head arches. This is also evident when looking at the contour plots of vertical displacements (Fig. 22), which are almost 65% smaller at the crown when walls are present.

Figure 22 also makes it possible to compare the displacement field between pitched and radial pattern with the same boundary conditions (i.e., with head walls). Despite the fact that

the maximum displacement at the crown is almost the same, with the pitched pattern the area which undergoes the highest displacements is more extended than in the radial pattern.

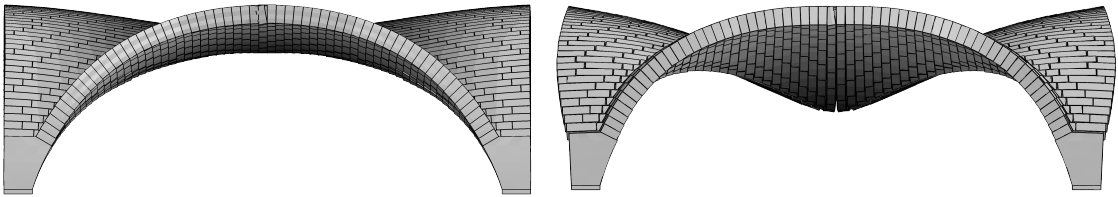

Fig 21 Radial cross vault with head walls (left) and without head walls (right) under self-weight (amplification factor =100)

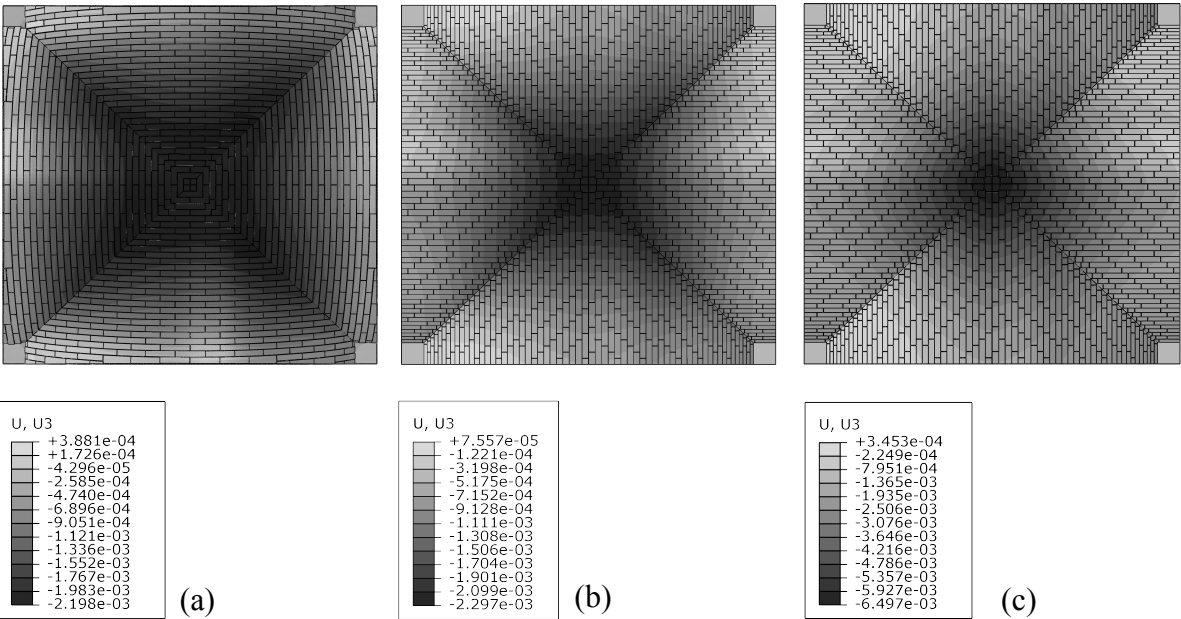

Fig 22 Vertical displacement [m] in cross vaults with a) pitched pattern, b) confined radial pattern, c) non-confined radial pattern

Finally, Fig. 23 plots the reaction forces at the abutments and at the head walls for the three stable configurations. The pitched pattern is the one which corresponds to the lowest vertical force at the abutments, since part of the vault’s self-weight is taken by the head walls, thanks to the bed joint inclination. The latter is also responsible for the highest horizontal thrust at the head walls. The same does not occur in the radial pattern, even when head walls are present, since all the vault’s self-weight is taken by the abutments.

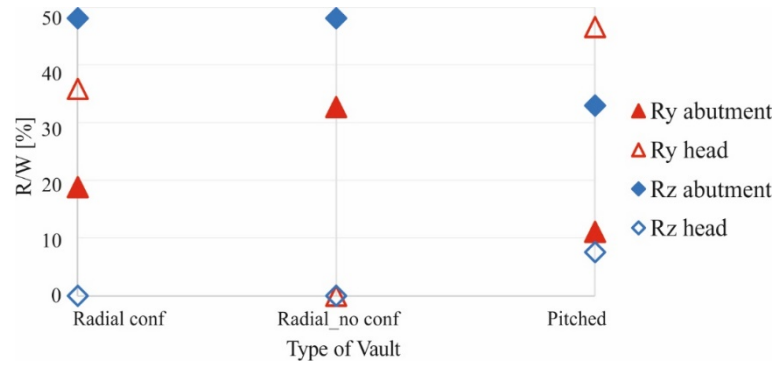

Fig 23 Cross vault reaction forces

4. Conclusions and Prospects

The analysis of the results evidenced a different response in terms of structural elastic stiffness and reaction forces. In particular, for barrel vaults, the vertical brick pattern is the one which provides the highest stiffness (i.e. the lowest vertical displacement at the crown). This result agrees with Lancaster’s observation on the preferable use of this pattern by the Romans, who aimed at strengthening the central area of the vault for reducing longitudinal cracking at the crown (Lancaster 2015). The vertical pattern on the barrel vault also induces the highest horizontal thrust at the abutments due to an almost planar behaviour. This finding is in contrast to Choisy’s statement (Choisy 1883). Conversely, radial and diagonal patterns are characterized by three-dimensional behaviour that results in lower thrust at the abutments but increased thrust against the head walls. This behaviour is more pronounced in the case of diagonal pattern and confirms what stated in the reviewed literature.

For cross vaults, the vertical pattern does not allow the static equilibrium of the structure, therefore only pitched configuration can be adopted if a parallel arch laying technique is chosen. However, in the latter case the static equilibrium strongly relies on the presence of the head walls. This issue should be taken into account in case of structural intervention on this kind of vault because the eventual removal of the head walls could compromise the structural stability. Conversely, when radial brick pattern is used, the presence of the head walls increases the stiffness of the structure by it is not essential for establishing the equilibrium.

Concluding, this study allowed to understand the crucial role of the micro-geometry of vaulted structures under their self-weight. The brick pattern is thus expected to have a significant influence also under different loading conditions (static and dynamic) and in case of differential settlements. This will be the object of future investigations by the authors.

ACKNOWLEDGEMENT

All figures are by the authors unless otherwise indicated.

REFERENCES

- Alforno, Marco, Chiara Calderini, Alessia Monaco and Fiammetta Venuti. 2019. Numerical modelling of masonry vaults with different brick pattern. *Proceedings of the IASS Annual Symposium 2019* (Barcelona, Spain).
- Baratta, Alessandro and Ottavia Corbi. 2012. The static behavior of historical vaults and cupolas. *Journal of Heritage Conservation* 32: 65-81.
- Barbieri, Alessandra, Christian Carloni and Angelo Di Tommaso. 2004. Masonry orthotropic vaults in historical construction: the herring-bone pattern. In *Proceedings of the 4th International Conference on Arch Bridges ARCH 04* (Barcelona, Spain).
- Besenal, Roland. 1984. *Technologie de la voute dans l'orient ancien*. Paris: Editions Recherche sur les Civilisations.
- Breymann, Gustav Adolf. 1849. *Allgemeine Bau-Constructions-Lehre, mit besonderer Beziehung auf das Hochbauwesen*. Vol. 1: *Constructionen in Stein*. Stuttgart: Hoffmann.
- Calderini, Chiara and Sergio Lagomarsino. 2004. The effect of the masonry pattern on the global behaviour of vaults. In *Proceedings of the 4th International Conference on Structural Analysis of Historical Constructions* (Padova, Italy).
- Cantalupi, Antonio. 1867. *Raccolta di tavole, formole ed istruzioni pratiche per l'ingegnere architetto e pel meccanico*. Milano: Tip. Domenico Salvi e Comp.
- Chevalley, Giovanni. 1924. *Elementi di tecnica dell'architettura: materiali da costruzione e grosse strutture*. Torino: Pasta.
- Choisy, Auguste. 1883. *L'art de batir chez les Byzantines*. Paris: Société anonyme de publications périodiques.
- Curioni, Giovanni. 1870. *L'arte di Fabbricare. Costruzioni civili, stradali, idrauliche*. Torino: Negro.
- De Cesaris, Fabrizio. 1996. Gli elementi costruttivi tradizionali. In *Restauro architettonico*, ed. G. Carbonara, vol. II. Torino: Utet.
- Fathy, Hassan. 1973. *Architecture for the poor: an experiment in Rural Egypt*. Chicago: Chicago University Press.
- Foraboschi, Paolo. 2014. Resisting system and failure modes of masonry domes, *Engineering Failure Analysis* 44: 315-337.
- Ger Y Lobe, Florencio. 1869. *Manual de Construcción Civil*. Badajoz: Imprenta de José Santamaria.
- Huerta, Santiago. 2004. *Arcos, bóvedas y cúpulas Geometría y equilibrio en el cálculo tradicional de estructuras de fábrica*. Madrid: Instituto Juan de Herrera.
- Lagomarsino, Sergio, Chiara Calderini. 2004. The effects of the masonry pattern on the global behaviour of vaults. *Proceedings of the 4th International Conference on Structural Analysis of Historical Construction* 2004. Lancaster, Lynne. 2015. *Innovative Vaulting in the Architecture of the Roman Empire*. New York: Cambridge University Press.
- Lassaulx, Johann Claudius. 1829. Beschreibung des Verfahrens bei Anfertigung leichter Gewölbeüber Kirchen und ähnlichen Raumen, *Journal für die Baukunst* 1(4): 317-330.

- Lourenco, Paulo, Jan G. Rots and Johan Blaauwendraad. 1995. Two approaches for the analysis of masonry structures - micro and macro-modeling,. *HERON* 40 (4): 313-340.
- Reuther, Oscar. 1938. Sasanian Architecture. A History, in *A Survey of Persian Art from Prehistoric Times to the Present*, ed. Arthur. U. Pope, Vol I. London: Oxford University Press.
- Rondelet, Jean B. 1831. *Trattato teorico e pratico dell'arte di edificare*, vol II. Mantova: Editrice coi tipi di Caranenti L.
- Rossi, Michela, Chiara Calderini, Sergio Lagomarsino. 2016. Experimental testing of the seismic in-plane displacement capacity of masonry cross vaults through a scale model. *Bulletin of Earthquake Engineering* 14: 261-281.
- Ungewitter, G. G. 1859. *Lehrbuch der gothischen Constructionen*. Leipzig: Weigel.
- Valadier, Giuseppe. 1992. *L'architettura pratica*. Roma: Sapere 2000.
- Van Beek, Gus W. 1987. Arches and Vaults in the Ancient Near East. *Scientific American* (July): 78-85.
- Wendland, David. 2007. Traditional vault construction without formwork: masonry pattern and vault shape in the historical technical literature and in experimental studies. *International Journal of Architectural Heritage* 1(4): 311-365.