

An op amp-less Electrochemical Impedance Spectroscopy System

*Original*

An op amp-less Electrochemical Impedance Spectroscopy System / Sebar, L.E., Angelini, E., Grassini, S., Iannucci, L., Parvis, M.. - ELETTRONICO. - (2020), pp. 1-6. (IEEE International Instrumentation and Measurement Technology Conference - I2MTC2020 Dubrovnik, Croatia 25-28 May 2020) [10.1109/I2MTC43012.2020.9129355].

*Availability:*

This version is available at: 11583/2841357 since: 2020-07-28T09:42:48Z

*Publisher:*

IEEE

*Published*

DOI:10.1109/I2MTC43012.2020.9129355

*Terms of use:*

This article is made available under terms and conditions as specified in the corresponding bibliographic description in the repository

*Publisher copyright*

IEEE postprint/Author's Accepted Manuscript

©2020 IEEE. Personal use of this material is permitted. Permission from IEEE must be obtained for all other uses, in any current or future media, including reprinting/republishing this material for advertising or promotional purposes, creating new collecting works, for resale or lists, or reuse of any copyrighted component of this work in other works.

(Article begins on next page)

© 2020 IEEE. Personal use of this material is permitted. Permission from IEEE must be obtained for all other uses, in any current or future media, including reprinting/republishing this material for advertising or promotional purposes, creating new collective works, for resale or redistribution to servers or lists, or reuse of any copyrighted component of this work in other works.

## ***An op amp-less Electrochemical Impedance Spectroscopy System***

*Leila Es Sebar, Emma Angelini, Sabrina Grassini, Leonardo Iannucci*  
*Dipartimento di Scienza Applicata e Tecnologia, Politecnico di Torino, Torino, ITALY*

*Marco Parvis*  
*Dipartimento di Elettronica e Telecomunicazioni Politecnico di Torino, Torino, ITALY*

**DOI: 10.1109/I2MTC43012.2020.9129355**

# An op amp-less Electrochemical Impedance Spectroscopy System

Leila Es Sebar  
Emma Angelini  
Sabrina Grassini  
Leonardo Iannucci

Dipartimento di Scienza Applicata e Tecnologia  
Politecnico di Torino, ITALY  
Email: leila.essebar@polito.it

Marco Parvis

Dipartimento di Elettronica e Telecomunicazioni  
Politecnico di Torino  
Torino, ITALY  
Email: marco.parvis@polito.it

**Abstract**—This paper describes an extremely low-cost device for performing Electrochemical Impedance Spectroscopy (EIS) measurements. The proposed instrument is arranged by using a simple Teensyduino board and it does not require any additional analog amplifier. The instrument is capable of measuring impedance values which can span about three decades, in the frequency range from 0.01 Hz to 10000 Hz. The proposed measuring system can be inserted in a remote laboratory infrastructure so as to allow the user to assess the corrosion behavior of metals not only performing single measurements but also during in situ long term monitoring.

**Index Terms**—EIS, Arduino, low cost instrumentation

## I. INTRODUCTION

Electrochemical Impedance Spectroscopy (EIS) is a common and powerful non invasive technique to study the corrosion behavior of metals and alloys both in the industrial and cultural heritage field [1]. EIS is also widely used to study several different electrochemical phenomena in lithium batteries and fuel cells [2], [3], [4], and in the medical field as well [5], [6], [7]; however, corrosion monitoring remains one of the main applications.

Basically EIS consists on the application of a small alternating voltage to a metallic object and in the measurement of amplitude and phase of the surface impedance at different frequencies in order to highlight either the protective effectiveness of a coating or the stability of the superficial oxide layer grown on its surface. EIS measurements allow also investigating the mechanism of the corrosion process occurring on the metal exposed to an aggressive environment.

The electrochemical impedance is closely related to the corrosion reactions and it is intrinsically a non-linear phenomenon that can be linearized if the working conditions are not perturbed. Since any material immersed in an electrolytic solution stabilizes at a specific potential, which depends on material and electrolyte, the alternating stimulus is usually applied around this potential so that an average zero current is experienced in the material.

Several instruments have been developed to measure the surface impedance, both for laboratory and for in situ measurements. In this paper a new extremely cheap EIS system is described. The proposed device can operate in both a limited

frequency and impedance range; however, it can be proposed for an easy and fast assessment of the corrosion behavior of metallic artifacts.

## II. ELECTROCHEMICAL IMPEDANCE SPECTROSCOPY

EIS consists in measuring the surface impedance of an object by using a conventional electrochemical cell whose simple scheme is shown in Fig. 1. A small alternating stimulus is applied between the so called 'Counter electrode', usually a platinum or titanium wire, and the so called 'Working electrode' which is the metal whose corrosion behavior has to be studied by measuring the current which flows into the working electrode as a consequence of the applied voltage.

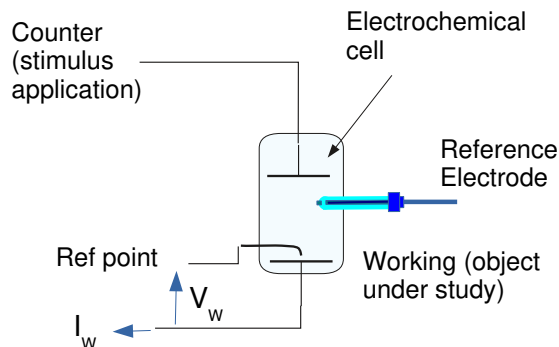

Fig. 1. Scheme of a conventional three electrode electrochemical cell for EIS measurements.

Both electrodes are immersed in an electrolyte which can be a non aggressive solution, e.g. a solution of sodium sulfate ( $Na_2SO_4$ ) in distilled water for non invasive measurements, or a solution containing different aggressive agents in order to simulate the environment to which the metal is exposed in its operating conditions. As an example, if marine corrosion has to be studied, artificial seawater or sodium chloride ( $NaCl$ ) solutions can be employed. Usually concentrations of 0.1 M or 1 M are used. When immersed into the electrolytic solution, both electrodes tend to reach an electrical potential referred to as 'Open Circuit Potential - OCP'. This potential can be measured respect to a Reference Electrode, which can be made

of different materials, as an example Silver/Silver Chloride ( $Ag/AgCl$ ), turning out in different measured OCPs, that usually are of the order of some hundreds of millivolts.

The impedance  $Z_W$  is defined as the ratio between the alternating voltage applied to the working electrode and the alternating current flowing in it. At a specific frequency  $f$ :

$$Z_W(f) = \frac{V_W(f)}{I_W(f)} \quad (1)$$

where  $V_W(f)$  is a complex number representing the applied voltage and  $I_W(f)$  is a complex number representing the flowing current. Such a current should have a mean value equal to zero, in order to avoid either any working electrode corrosion or deposition.

This condition is usually obtained by means of a potentiostat, the electronic hardware required to control a three electrode cell and run most electroanalytical experiments. Otherwise, it can be obtained if the applied voltage has an average value equal to the OCP difference between the working and the counter electrode:

$$V_C = V_{OCP_C} - V_{OCP_W} + V_{alt} \sin(2\pi ft) \quad (2)$$

where  $V_{OCP_C}$  and  $V_{OCP_W}$  are the OCPs of counter and working,  $t$  is the time,  $V_{alt}$  is the applied signal amplitude usually in the range of 0.01 V to 1 V and  $f$  is the signal frequency, usually in the range of 0.01 Hz to 100 kHz.

The working voltage ( $V_W$ ) may be different from the counter voltage ( $V_C$ ) due to the electrolyte impedance and therefore the counter electrode has to be placed close to the working electrode.

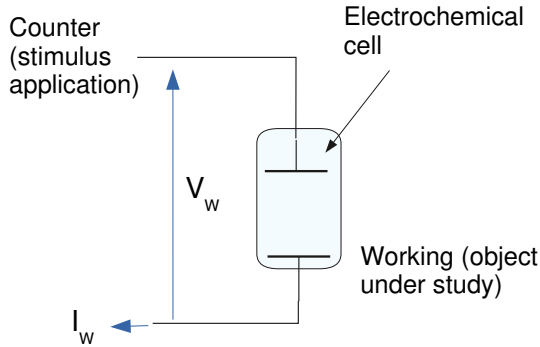

Fig. 2. Simplified 2-electrode electrochemical cell.

If the OCPs need not to be measured, the reference electrode can be avoided and this may lead to a simplified 2-electrode cell (Fig. 2). In this case the applied signal becomes:

$$V_C = V_{OP} + V_{alt} \sin(2\pi ft) \quad (3)$$

where  $V_{OP} = V_{OCP_C} - V_{OCP_W}$  is the Open Potential measured without applying any stimulus after the immersion of working and counter electrode in the electrolyte.

Once the impedance  $Z_W$  is measured in the entire frequency range, the impedance spectra are fitted by means of a suitable

equivalent circuit model, which represents the working electrode/electrolyte interface and must have a physical meaning. Typically, the equivalent circuit model contains simple electrical components, such as resistors and capacitors, like the one shown in Fig. 3, and it has an impedance which increases at low frequencies.

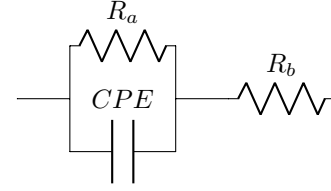

Fig. 3. Example of a simple equivalent circuit model for fitting EIS spectra.

In corrosion monitoring studies, capacitors are often Constant Phase Elements (CPE) to take into account the diffusion of electrolyte and aggressive agents through the surface corrosion products layer till the metal; a CPE is a device whose impedance is expressed by the equation:

$$X = \frac{1}{C(j\omega)^n} \quad (4)$$

where  $\omega = 2\pi f$  represents the measurement frequency,  $j$  is the imaginary unit,  $C$  is the CPE value and  $n$  is an exponent ranging between 0 and 1; when  $n = 0$  the CPE behaves like a resistor, when  $n = 1$  the CPE behaves like a capacitor and when  $n = 0.5$  the CPE models a pure diffusion element.

The impedance is usually graphically represented as either a Bode or Nyquist plot. As an example, the expected plot when  $R_a = 500 \text{ k}\Omega$ ,  $C = 0.5 \cdot 10^{-6} \text{ }\Omega^{-1}\text{s}^{-n}$ ,  $n = 0.5$ ,  $R_b = 2 \text{ k}\Omega$  is shown in Fig. 4.

### III. THE PROPOSED EIS SYSTEM

Nowadays several EIS measurement systems based on different technologies are commercially available [9], [8]. Moreover, other low cost devices, which still require the development of specific analogue interfaces to work in a wide frequency and impedance range (over 7 decades in impedance modulus), have been recently developed [11], [12], [10].

However, if the impedance modulus range is limited to less than four decades, a much more simple measuring system can be arranged. The solution can rely on a simple off-the-shelf microcontroller board, without any need of additional circuit.

What is required is a device capable of generating an analogue signal and acquire at least two analogue signals in order to apply the stimulus and acquire both voltage and current to compute the impedance.

The acquisition requirement of two signals is satisfied by almost every microcontroller board on the market, while the capability of generating the analogue stimulus leaves out boards, like Arduino UNO which employs 8 bits ATMEL microcontrollers.

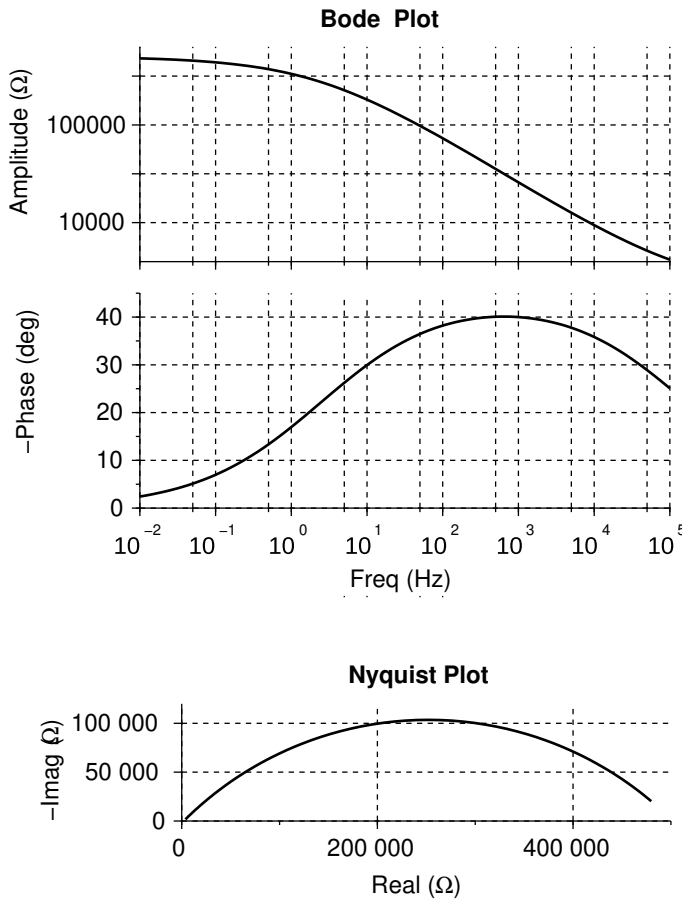

Fig. 4. Bode and Nyquist plots obtained for the electrical circuit represented in Fig. 3 where  $R_a = 500 \text{ k}\Omega$ ,  $C = 0.5 \cdot 10^{-6} \text{ }\Omega^{-1}\text{s}^{-n}$ ,  $n = 0.5$ ,  $R_b = 2 \text{ k}\Omega$ .

The proposed EIS system works with a TeensyDuino 3.2 board [13], equipped with a ARM Cortex-M4, 32 bits microcontroller which embed all the required components, i.e.:

- a 12 bit DAC (Digital to Analog Converter) capable of working with a clock in excess of 500 kHz and generating an analogue signal in the range of 0 V to 3.3 V;
- two 16 bits ADC (Analog to Digital Converter), capable of sampling signals with amplitudes in the range of 0 V to 3.3 V, which can be run synchronously in parallel and are provided each with a differential programmable gain amplifier (PGA) that can amplify the signal sent to the ADCs up to 64;
- a microcontroller core with several timers which can be used to pace independently both the DAC end the ADCs;
- an USB connection to transfer data to any Personal Computer.

The board can be programmed by using the Arduino IDE environment and the microcontroller has a local memory for the code of 256 kBytes and a RAM memory to store the acquired data of 64 kBytes.

The only real limitation of employing this board for devel-

oping the proposed measuring approach is the DAC and ADCs capability of working only with positive voltages in the range of 0 V to 3.3 V, even though the PGAs can accept negative voltages, provided that they never exceed the above limited voltage range.

A complete EIS measuring system therefore can be arranged as detailed in Fig. 5, which also shows a picture of the TeensyDuino 3.2 board.

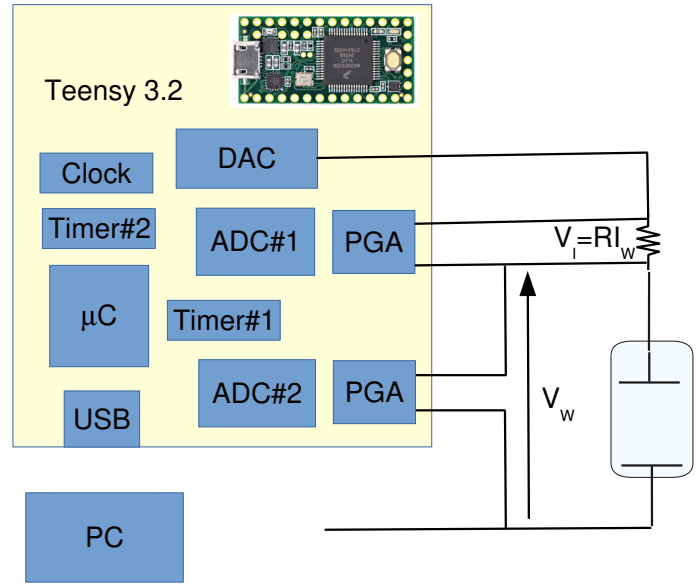

Fig. 5. Teensyduino based EIS system.

The figure show:

- The electrochemical cell. Working and counter electrodes are not marked on the figure because, since the board can handle only positive voltages, the electrode selection depends on the measured OCPs which have to provide a positive voltage difference. Such selection does not impact the instrument behavior since the impedance is always obtained as the ratio between the measured voltage and the flowing current, both corrected according to the electrode choice.
- The DAC which is responsible for providing the stimulus signal and the average voltage equal to the counter and working OCP difference. The DAC has a resolution of 12 bits which correspond to about  $800 \text{ }\mu\text{V}$  for each bit. The signal generation can be obtained by scanning a look-up table with the digital codes corresponding to the alternating voltage superposed to the OCP value. Since the DAC can be triggered with time intervals down to 50 ns, theoretically a frequency of 100 kHz might be generated with 200 samples.
- The resistor which acts as the shunt to provide the current measurement. Since the PGA can provide a gain of maximum 64, the voltage range on the resistor can be of the order of  $\pm 50 \text{ mV}$  to have a full range measurement on the ADC and less than 2 mV for a digital range of  $\pm 1000$ . As an example, by using a resistor of  $1 \text{ k}\Omega$  a

current of less than  $2 \mu\text{A}$  can be measured, while by using a resistor of  $10 \text{ k}\Omega$  the current limit drops to less than  $200 \text{ nA}$ .

- The ADC-PGA#2 block for measuring the voltage applied between the counter and the working electrode. In the picture, the PGA has differential inputs directly connected to the two electrodes, so no errors are related to the shunt resistor presence; however one of the input wires can be moved directly to the DAC output provided that a correction for the shunt resistance is performed. Since the OCP difference can be of the order of  $1 \text{ V}$ , the PGA should probably be used with a gain of 1. This block is also used to measure the OCP difference between working and counter electrodes, once the DAC is electronically disconnected.
- The ADC-PGA#1 block used to measure the voltage across the shunt and therefore the current. The two ADCs can be run synchronously with a pacing of less than  $2 \mu\text{s}$ , theoretically up to 20 samples might be obtained during a single period of a signal at  $50 \text{ kHz}$ .
- The timers, which are used to pace both DAC and ADCs. The Cortex M4 has several timers, which can be run independently. In this case only two timers are used: one for pacing the the DAC and one for pacing the ADCs. Both timers run from the same clock which can be up to  $96 \text{ MHz}$ .
- The USB interface which can be used to transfer all data to the PC. The serial line speed can be set in the range of  $9600 \text{ bit/s}$  to about  $2000000 \text{ bit/s}$ . By using a standard baud rate of  $115200 \text{ bit/s}$  more than 10000 characters per second can be easily transmitted.
- the PC which connects to the Teensy board via USB and process the data to obtain the impedance spectra.

#### IV. MEASUREMENTS AND UNCERTAINTIES

Using the proposed EIS system on real artifact does not allow one to asses the device performance because the surface impedance evolves with time as a function of the corrosion reactions occurring on the metal. Therefore, several measurements have been performed on fixed electrical components whose values can be measured independently.

##### A. ADC and PGA test at gain 1

The first set of measurements has been performed by connecting the two channels in parallel and setting both PGA gains to 1. In this case both amplitudes should be the same with ratio equal to one, while the phase difference should be zero. Fig. 6 shows, an example, the obtained data in the frequency range of  $0.1 \text{ Hz}$  to  $10 \text{ kHz}$  and for amplitudes in the range of  $0.1 \text{ V}$  to  $1.5 \text{ V}$ . The ratio between the two channels is about  $0.9965$  with a maximum change of less than  $0.3\%$  while the phase error is below  $1^\circ$ . Going to amplitudes of  $10 \text{ mV}$  with PGA gain of 1 and therefore with codes which changes of below 100, leads to a ratio of error of only  $2\%$  and a maximum phase error of  $2^\circ$ . Similar results have been

obtained with PGA gains of 4 and 8 with ratios of about 1 and uncertainty of less than  $0.3\%$ .

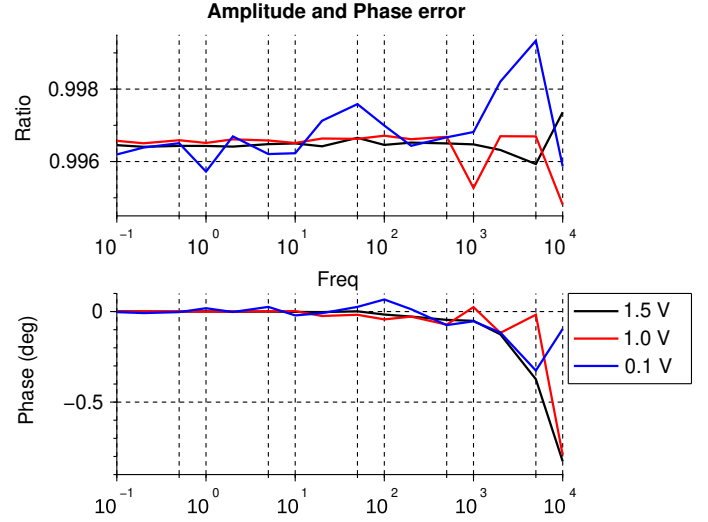

Fig. 6. Amplitude estimations and phase differences for channels connected in parallel.

##### B. ADC and PGA tests as different gains

The Teensy ADCs have PGA which can be enabled in front of them, and the manufacturer states that an high input source impedance can reduce the PGA nominal gain even though no specific values are given. In addition, the input PGA impedance decreases as the PGA gain increases so that the actual shunt resistance decreases as the PGA gain increases and the measured voltage values are affected by the PGA impedance. This affects both the input channels, however the voltage channels always uses gain equals to one so that its effect in this case is almost constant and its correction fixed.

Since measuring the current through a shunt resistor may imply not negligible resistances, a test has been performed to measure the actual PGA gain. The test has been performed by using the circuit shown in Fig. 7 with  $R_s = 1 \text{ k}\Omega$ ,  $R = 100 \text{ k}\Omega$  and  $V = 0.5 \text{ V}$ .

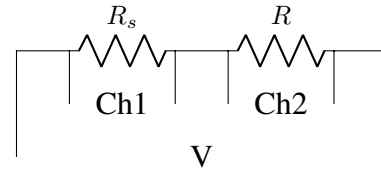

Fig. 7. Circuit used for the PGA gain test.

The measured resistance  $R_m$  is obtained as:

$$R_m = \frac{V_{Ch2}}{V_{Ch1}/R_s} \quad (5)$$

while the actual resistance  $R$  and the actual shunt resistance  $R_{as}$  are obtained as:

$$R = \frac{R_m \cdot R_{pgaV}}{R_{pgaV} - R_m} \quad (6)$$

$$R_{as} = \frac{R_s \cdot R_{pgaI}}{R_s + R_{pgaI}} \quad (7)$$

where  $R_{pgaV}$  and  $R_{pgaI}$  are the input PGA resistances whose value depends on the gain and is in the range of 32 k $\Omega$  to 128 k $\Omega$ . Fig. 8 shows the gain to be applied instead of the nominal PGA gain.

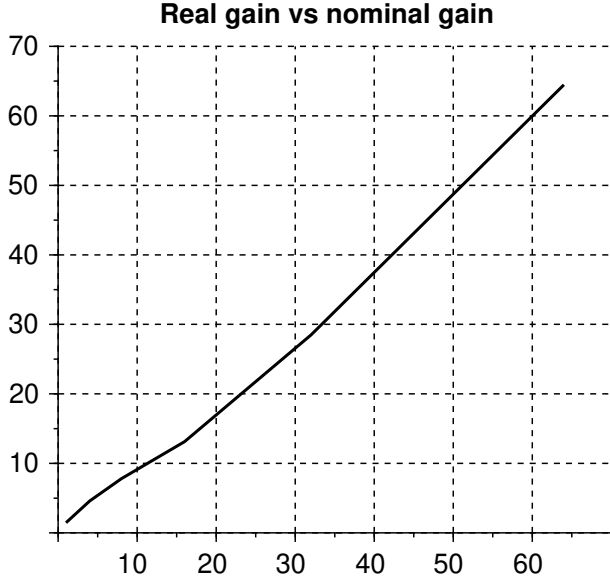

Fig. 8. Effect of different PGA nominal values on the estimated resistance.

The gain is expected not to change with the frequency and this is confirmed by the standard deviation of the computed resistance which is always below 250  $\Omega$ , i.e. below 0.25%. Of course, since in this test the stimulus is kept fixed to  $\pm 0.5$  V maximum, the current is limited 50  $\mu$ A maximum, and the voltage across the shunt resistance limited to 50 mV maximum. This turns out in a quite limited ADC code change especially when the PGA gain is at minimum levels. Fig. 9 shows the maximum code difference measured for the different PGA gains.

### C. Impedance test with a simulated cell

The proposed system has been eventually tested on a simulated electrochemical cell whose scheme is shown in Fig. 10. The figure shows the shunt resistor  $R_s = 1$  k $\Omega$ , a capacitor  $C = 0.1$   $\mu$ F, a resistor  $R_1 = 100$  k $\Omega$  and a resistor  $R_2 = 100$  k $\Omega$ . The resistor  $R_p = 330$   $\Omega$  and the diode are used to add a fixed voltage to the measurement as in a real electrochemical cell. Since the diode cannot be considered as an ideal voltage source, in the first measurements it has been removed obtaining the results shown in Fig. 11. The figure shows the results obtained by using different values on stimulus amplitude compared with the expected impedance. The difference is minimal especially at low frequencies and the phase is correctly estimated.

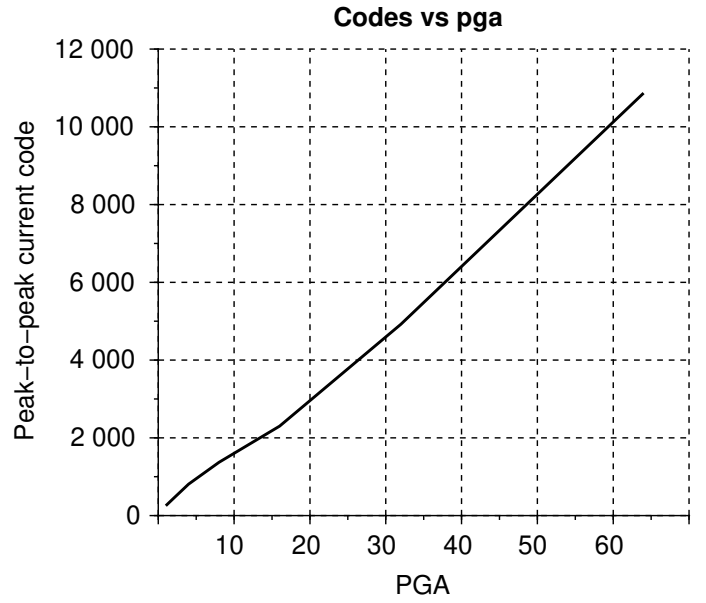

Fig. 9. Effect of different PGA values on current peak to peak codes.

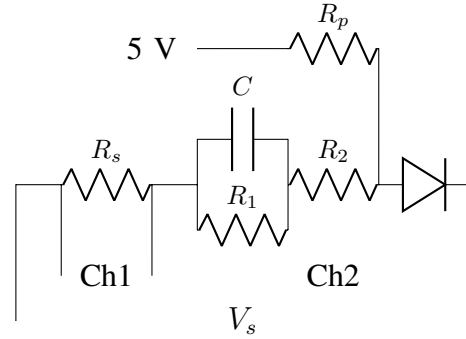

Fig. 10. Circuit used for the PGA gain test.

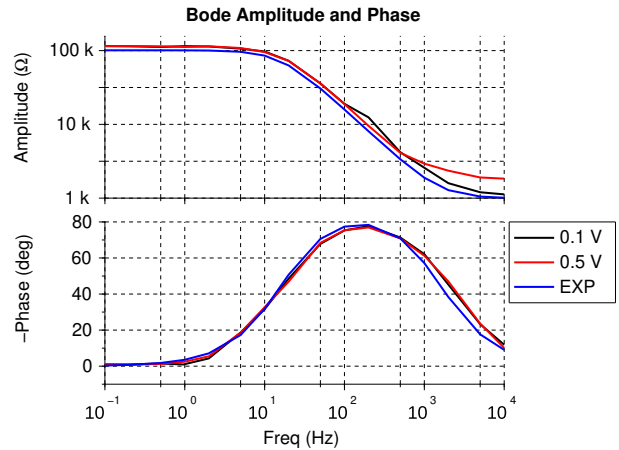

Fig. 11. Estimated impedance values and the expected value by using the nominal value of the components.

The measurements remain the same also when the fixed voltage which emulate the OCP is inserted. Fig. 12 shows the

obtained results by using a stimulus of 0.1 V

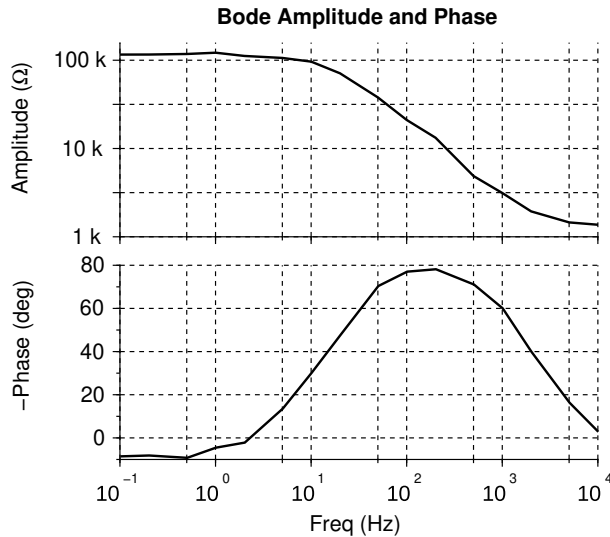

Fig. 12. Estimated impedance values in the presence of the fixed voltage which emulates the OCP and for a stimulus amplitude of 0.1 V.

## V. MEASUREMENTS ON REAL METALLIC SAMPLES

Measurements on real metallic samples have been performed and the obtained EIS spectra have been compared with those collected by means of a commercial instrument. One should note that, by measuring a real sample whose surface corrodes and by having to carry out the measurements with both instruments in different times, an exact comparison cannot be performed because the corrosion reaction proceeds as a function of the exposure time of the metal to the electrolyte. However, since the time interval between the two measurements is kept short, both EIS spectra shape and the impedance phase and amplitude values remain similar.

Fig. 13 presents an example of the obtained results on the metallic sample shown at top right of the figure. The measured sample is a weathering steel sheet coated with a thin corrosion products layer. The measurement has been performed using a small electrochemical cell, designed by the authors, with a Pt wire as the counter electrode. The exposed surface area is about  $0.5 \text{ cm}^2$ , but the measured values have been normalized to a surface area of  $1 \text{ cm}^2$ .

## VI. CONCLUSIONS

The proposed EIS system is capable of performing electrochemical impedance measurements on real metallic artifacts for monitoring their corrosion behavior. The device has been arranged with the Teensyduino board, which has an average cost of only (20\$). The proposed system is not suitable to measure high impedance values, like the ones expected on metallic samples coated with organic protective layers, but represents a real, cheap and easily available alternative for in situ measurements. As a matter of facts, the proposed device can be easily integrated into more complex infrastructures for remote management of the measurements and experiments [14].

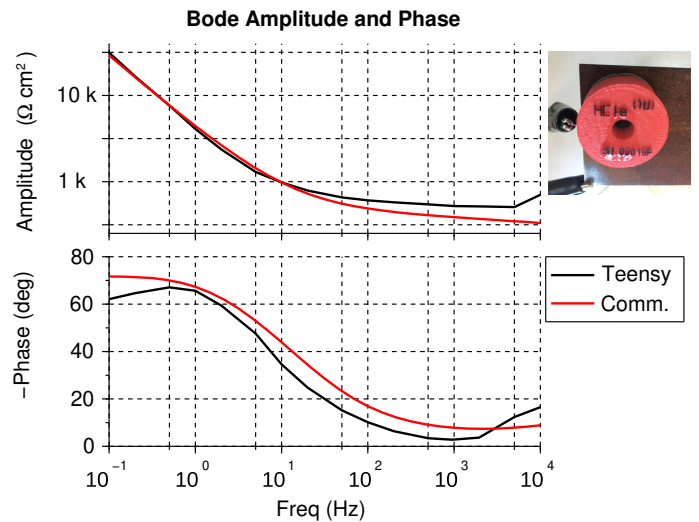

Fig. 13. Comparison of the impedance spectra obtained using a commercial device and the proposed one.

## REFERENCES

- [1] E. Angelini et al., 'Indoor and outdoor atmospheric corrosion monitoring of cultural heritage assets', *Metallurgia Italiana*, vol. 4, pp. 34-41, 2018
- [2] A. Guha, A. Patra, 'Online Estimation of the Electrochemical Impedance Spectrum and Remaining Useful Life of Lithium-Ion Batteries', *IEEE Transactions on Instrumentation and Measurement*, vol. 67, no. 8, pp. 1836-1849, 2018
- [3] G. Dotelli et al., 'Analysis and Compensation of PEM Fuel Cell Instabilities in Low-Frequency EIS Measurements' *IEEE Transactions on Instrumentation and Measurement*, vol. 63, no. 7, pp. 1693-1700, 2014
- [4] M. Marracci et al. 'Ultracapacitor Degradation State Diagnosis via Electrochemical Impedance Spectroscopy', *IEEE Transactions on Instrumentation and Measurement*, vol. 64, no. 7, pp. 1916-1921, 2015
- [5] Y.A. Glickman et al., 'Novel EIS postprocessing algorithm for breast cancer diagnosis', *IEEE Transactions on Medical Imaging*, vol 21, no 6, pp. 710-712, 2002
- [6] Tung-Ming Pan et. al. 'High-k  $Tm_2Ti_2O_7$  Electrolyte-Insulator-Semiconductor Creatinine Biosensor', *IEEE Sensors Journal*, vol. 11, no. 10, pp. 2388-2394, 2011
- [7] R.H. Smallwood et al. 'Electrical impedance spectroscopy (EIS) in the urinary bladder: the effect of inflammation and edema on identification of malignancy', *IEEE Transactions on Medical Imaging*, vol 21, no 6, pp. 708-710, 2002
- [8] Palmsens website freely available at <https://www.palmsens.com/frequency-response-analyzer/> last checked at 2019-11-05
- [9] Ametek website freely available at <https://www.ameteksi.com/products/frequency-response-analyzers> last checked at 2019-11-05.
- [10] E. Angelini et al. Handheld-impedance-measurement system with seven-decade capability and potentiostatic function, *IEEE Transactions on Instrumentation and Measurement*, vol. 55, no. 2, pp. 436-441, 2006.
- [11] A. Carullo et al. 'Low-cost electrochemical impedance spectroscopy system for corrosion monitoring of metallic antiquities and works of art', *IEEE Transactions on Instrumentation and Measurement* vol. 49, no. 2 pp 371 - 375, 2000
- [12] S. Grassini et al, Low-Cost Impedance Spectroscopy System Based on a Logarithmic Amplifier, *IEEE Transactions on Instrumentation and Measurement*, vol. 64 no. 5, pp. 1110-1117, 2014
- [13] PJRC, '<https://www.pjrc.com/store/teensy32.html>' freely availab on the internet, last checked on 2019-11-05
- [14] L.Iannucci et al 'iHomeX: An Internet-Enabled Laboratory for Long-Term Experiment Management', *IEEE Transactions on Instrumentation and Measurement*, vol 67, no. 5, pp. 1142-1149, 2018