

Parametric analysis of a dual band polarized frequency selective surface

*Original*

Parametric analysis of a dual band polarized frequency selective surface / Silaghi, A. -M.; De Sabata, A.; Matekovits, L.. - ELETTRONICO. - (2019), pp. 941-942. ( 2019 IEEE International Symposium on Antennas and Propagation and USNC-URSI Radio Science Meeting, APSURSI 2019 Atlanta, GA, USA, USA 7-12 July 2019) [10.1109/APUSNCURSINRSM.2019.8889112].

*Availability:*

This version is available at: 11583/2835622 since: 2020-06-19T12:17:38Z

*Publisher:*

Institute of Electrical and Electronics Engineers Inc.

*Published*

DOI:10.1109/APUSNCURSINRSM.2019.8889112

*Terms of use:*

This article is made available under terms and conditions as specified in the corresponding bibliographic description in the repository

*Publisher copyright*

IEEE postprint/Author's Accepted Manuscript

©2019 IEEE. Personal use of this material is permitted. Permission from IEEE must be obtained for all other uses, in any current or future media, including reprinting/republishing this material for advertising or promotional purposes, creating new collecting works, for resale or lists, or reuse of any copyrighted component of this work in other works.

(Article begins on next page)

# Parametric Analysis of a Dual Band Polarized Frequency Selective Surface

Andrei – Marius Silaghi  
Dept. of Measurements and Optical  
Electronics  
University Politehnica Timisoara  
Timisoara, Romania  
andrei.silaghi@student.upt.ro

Aldo De Sabata  
Dept. of Measurements and Optical  
Electronics  
University Politehnica Timisoara  
Timisoara, Romania  
aldo.de-sabata@upt.ro

Ladislau Matekovits  
Dept. of Electronics and  
Telecommunications  
Politecnico di Torino  
Torino, Italy  
ladislau.matekovits@polito.it

**Abstract**—A non-symmetrical single-layer frequency selective surface (FSS), which exhibits a highly stable response to incidence up to 45° is proposed for filtering applications. The structure consists of a set of three dipoles grouped in an “U”-like shape on the same side of an FR4 substrate. A parametric analysis concerning the frequency response in function of the angle of incidence is reported. The structure exhibits a dual band-stop response dependent on the polarization of the incident wave, so it can be tailored to achieve a polarizer.

**Keywords**—FSS, polarizer, LTE.

## I. INTRODUCTION

In the past, the authors have been interested in the problem of designing Frequency Selective Surfaces [1], [2]. They first started with the design of an FSS based on a combination of a Jerusalem Cross on a side and circular ring on the other side [1]. The proposed solution was assessed for TE and TM wave incidence for angles up to 45°, and it was used for filtering in the WLAN band and X band [1].

Afterwards, they proposed another two-layer FSS consisting of a fan shape resonator on one side and a square ring on the other side [2]. The structure exhibited a band-stop response with two notches and the possibility to be transformed in a wideband filter [2].

In this paper, a one sided FSS proposed for polarization-sensitive filtering applications is reported. The structure is built on a FR4 substrate, with a set of three dipoles on one side. The filtering properties are assessed with a commercial solver [3]. Parametric studies are undergone to demonstrate the polarizer aspect and the stability with respect to the angle of incidence of the structure.

Even if in the literature there are some works to build polarizers from FSS [4], [5], [6], the topic remains a challenging one especially when the angle of incidence is going to be varied. The present work proposes a reduced complexity structure to answer to such a practical issue with final design goal on the LTE band, commonly used in the automotive industry.

## II. PROPOSED STRUCTURE

### A. Initial Structure

The unit cell of the FSS is presented in Fig.1. It consists of a set of three dipoles made from copper on one side of an FR4 substrate. The dimensions are as follows: substrate thickness=3.2 mm, substrate relative dielectric constant=4.4, dimensions of the unit cell:  $d_x=d_y=12$  mm, length of dipoles=11 mm, width of dipoles=0.2 mm, displacement of dipoles from the center of the unit cell  $d_l=5.2$  mm (the same for all three). The FSS results by 2D repetition of the unit cell in the  $d_x$  and  $d_y$  directions [1], [7].

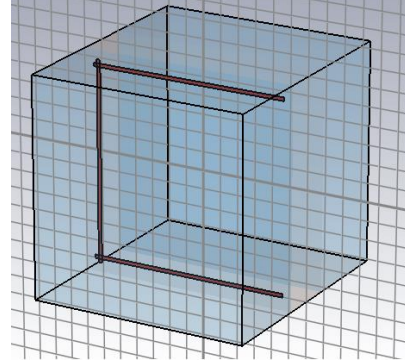

Fig. 1 Unit cell of the dual-band polarizer.

In Fig. 2 and Fig. 3 the band-stop properties between 0 and 8 GHz of the structure obtained using a commercial solver [3] is reported. Firstly, the transmission coefficient of a linearly polarized wave in normal incidence case is calculated. In the following, incidence of the wave from the metalized face of the structure has been considered.

In Fig. 2 the first notch, frequency (2.87 GHz) with an attenuation of 29.88 dB can be seen. In this case, the **E** field of the incident TEM wave was set to be parallel to the single dipole (case 1).

In Fig. 3 the second notch frequency (6.05 GHz) with an attenuation of -28.79 dB can be noticed. In this case, the **E** field of the incident TEM wave has been rotated by 90°, i.e., it is parallel to the pair of dipoles (case 2).

Note that the attenuation at 6.05 GHz is 0.97 dB in Fig. 2, and the attenuation at 2.87 GHz is 2.03 dB in Fig. 3, thus the proposed structure works as a dual-band polarizer.

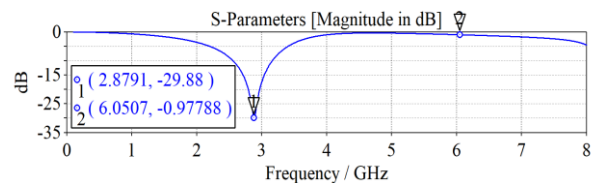

Fig. 2 Transmission coefficient in normal incidence with electric field vector parallel to the single dipole (case 1).

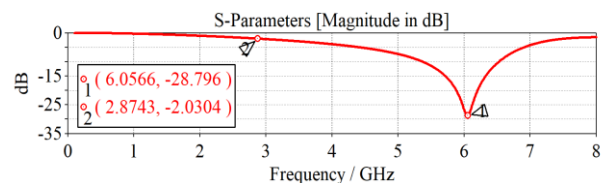

Fig. 3 Transmission coefficient in normal incidence with electric field vector aligned with the pair of parallel dipoles (case 2).

### III. PARAMETRIC STUDY

To assess the sensitivity with respect to the angle of incidence of the electromagnetic plane wave, a parametric study on the structure in Fig. 1 has been performed.

In Fig. 4 and Fig. 5 results of parametric variation of the colatitude angle ( $\theta$ ) with azimuth  $\phi=0$  (the azimuth is defined with respect to the  $x$  axis that is parallel to the aligned pair of dipoles in Fig. 1; the  $z$  axis is orthogonal to the unit cell) have been reported. This parameter has been varied between  $0$  and  $45^\circ$  in 4 steps. Consistency for both bands ( $2.87$  GHz and  $6.05$ ) can be seen in this case and so the structure is insensitive to angular modification.

Because the structure is not symmetrical, the case with azimuth  $\phi$  modified to  $90^\circ$  has also been investigated. In Fig. 6 and Fig. 7 again the parametric variation for  $\theta$ , this time with  $\phi$  modified according to the above statement can be seen. The same behaviour as above can be noticed and so the structure is insensitive to angular modification even if we modify  $\phi$ .

Because of space limitation, results of a more exhaustive parametric studies, concerning influence of geometrical dimensions, are not included in the present paper, but will be reported during the conference presentation.

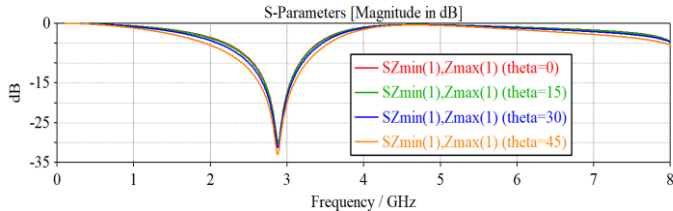

Fig. 4 Parametric study for  $\theta$  ( $\phi=0$ ), incidence case 1 in Fig. 2.

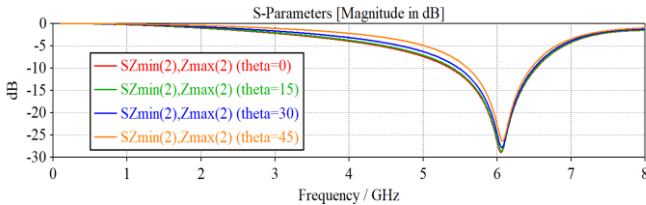

Fig. 5 Parametric study for  $\theta$  ( $\phi=0$ ), incidence case 2 in Fig. 3.

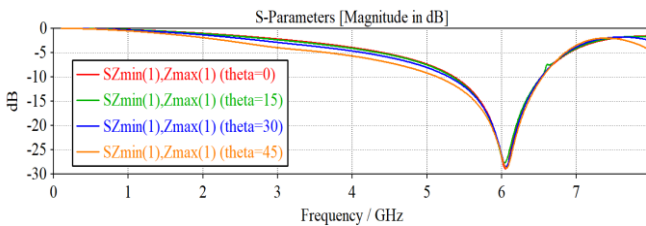

Fig. 6 Parametric study for  $\theta$  ( $\phi=90^\circ$ ), case 1

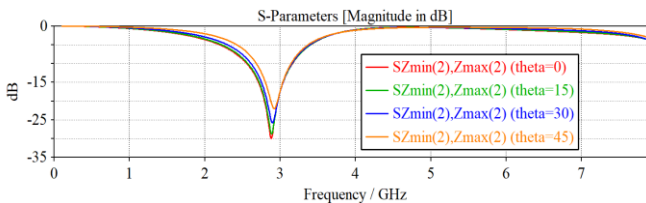

Fig. 7 Parametric study for  $\theta$  ( $\phi=90^\circ$ ), case 2.

For example, it can be shown that the device can be used for polarization-sensitive screening in the LTE frequency bands for some specific values of the geometrical parameters. The subject of Screening LTE bands [8] is of great interest for the automotive industry because of the high interferences that could occur inside a car between a mobile phone working in LTE band and other electronic devices.

### IV. CONCLUSIONS

In this paper, a FSS built on a FR4 substrate, with a unit cells consisting of a copper pattern of three dipoles in a U shape on the top side has been proposed. The potential for applications of the FSS has been demonstrated by simulation with an electromagnetic CAD software package. It has been established that the proposed structure can work as a dual-band polarizer.

In this configuration, the frequency response of the device can be adjusted for different applications, e.g. in the LTE frequency band. The final design is intended for applications in an automotive environment also because of its angular stability.

### ACKNOWLEDGMENT

The authors wish to acknowledge the support given by Continental Automotive Timisoara (Qualification Laboratory). This work was supported by a grant of the Romanian Ministry of Research and Innovation, CCDI-UEFISCDI, project number PN-III-P1-1.2-PCCDI-2017-0917/ contract number 21PCCDI.2018, within PNCDI III.

### REFERENCES

- [1] A. Buta, A. De Sabata, C. Iftode, A. Silaghi, L. Matekovits, Applications of a Frequency Selective Surface Based on a Combination of a Jerusalem Cross and Circular Ring, 2018 International Conference on Communications (COMM), 14-16 June 2018, Bucharest (Romania), pp. 239-242, 2018.
- [2] A. De Sabata, L. Matekovits, A. Silaghi, Frequency Selective Surface with two Notch Frequencies and Good Incidence Angle Stability for Screening Applications, Proc. 20<sup>th</sup> International Conference on Electromagnetics in Advanced Applications (ICEAA 2018), pp. 679 - 682, 10-14 Sept. 2018, Cartagena (Columbia).
- [3] CST, Computer Simulation Technology (v2018).
- [4] M. Saikia, S. Ghosh, K. Srivastava, Design and Analysis of Ultrathin Polarization Rotating Frequency Selective Surface Using V-Shaped Slots, IEEE Antennas and Wireless Propagation Letters, Vol. 6, pp. 2022-2025, 2017.
- [5] C. Jin, Q. Lv, R. Mittra, Dual-Polarized Frequency Selective Surface with Two Transmission Zeros based on Cascaded Ground Apertured Annular Ring Resonators, IEEE Transactions on Antennas and Propagation, Vol. 66, issue 8, pp. 4077-4085, 2018.
- [6] A. Osipov, B. Jonsson, Evaluation of the Electric Polarizability for Planar Frequency Selective Arrays, IEEE Antennas and Wireless Propagation Letters, Vol. 17, issue 7, pp. 1158-1161, 2018.
- [7] B.A. Munk, Frequency Selective Surfaces - Theory and Design, New York: Wiley, 2000.
- [8] F. Bağcı, S. Can, E. Karakaya, C. Mulazimoglu, A. Yilmaz, B. Akaoglu, Optically transparent frequency selective surface for filtering 2.6 GHz LTE band, 2017 IV International Electromagnetic Compatibility Conference (EMC Turkiye), 24-27 September 2017, Ankara (Turkey), pp. 1-4, 2017.