

Vibration Sensing for Deployed Metropolitan Fiber Infrastructures

Original

Vibration Sensing for Deployed Metropolitan Fiber Infrastructures / Di Luch, I.; Ferraro, M.; Rizzelli, G.; Gaudino, R.; Boffi, P.. - ELETTRONICO. - (2020), pp. 1-3. (2020 Optical Fiber Communications Conference and Exhibition, OFC 2020 San Diego, California United States 08-12 March 2020) [10.1364/OFC.2020.Th3F.6].

Availability:

This version is available at: 11583/2831075 since: 2020-06-05T10:33:32Z

Publisher:

Optica Publ. Group

Published

DOI:10.1364/OFC.2020.Th3F.6

Terms of use:

This article is made available under terms and conditions as specified in the corresponding bibliographic description in the repository

Publisher copyright

Optica Publishing Group (formely OSA) postprint/Author's Accepted Manuscript

“© 2020 Optica Publishing Group. One print or electronic copy may be made for personal use only. Systematic reproduction and distribution, duplication of any material in this paper for a fee or for commercial purposes, or modifications of the content of this paper are prohibited.”

(Article begins on next page)

Vibration Sensing for Deployed Metropolitan Fiber Infrastructures

Ilaria Di Luch^{1}, Maddalena Ferrario¹, Pierpaolo Boffi¹,
Giuseppe Rizzelli², Roberto Gaudino²*

¹ Politecnico di Milano, Dept. of Electronic Information and Bioengineering, via Ponzio 34/5, Milano, Italy

² Politecnico di Torino, Dept. of Electronics and Telecommunications, Corso Duca degli Abruzzi 24, Torino, Italy

*ilaria.diluch@polimi.it

Abstract: A counter-propagating coherent vibration sensing approach is exploited in a 32km deployed fiber ring network, proving its feasibility in early detection of critical events that may damage and put out of service the optical infrastructure.

1. Introduction

Nowadays, optical metropolitan networks are often organized on optical ring topologies used, for example, as the primary link of active access networks, where the interconnection between the different network sections takes place through switching devices (e.g. Optical Add Drop Multiplexer) [1]. The ring layout opens the possibility of new sensing applications that can run on a dedicated wavelength in parallel to all the other DWDM wavelengths carrying telecom traffic, providing added value to fiber optic infrastructure. Recently, the authors of this paper demonstrated the possibility of using a deployed passive optical network (PON) infrastructure for structural vibration monitoring in smart city applications with the simultaneous downstream of a 10-Gb/s NRZ signal [2]. In that case, a coherent (i.e. interferometric) sensing approach was proposed for vibration monitoring at locations known a priori at the optical network unit (ONU) side, that is, in correspondence of one of the final PON splitter terminals, where selected fibers were dedicated to sensing purposes. In the present work, thanks to a counter-propagating layout along the metro ring, we propose a coherent sensing technology that allows to detect and even localize along the entire link the onset of vibrations or dynamic stress applied to the fiber.

Experimental demonstration is presented for a deployed 32-km ring cable running in the city of Turin, Italy and devoted to telecommunication applications. The mechanical stress events monitored and localized by the proposed sensor can be caused, for example, by road works too close to the deployed fiber cable. Damages or breakages of optical telecommunication infrastructure are in fact current topical issues that can cause prolonged out of service, requiring time-consuming and high-cost repairs. In this frame, the sensing system proposed in this work provides a simple and reliable solution for optical network surveillance, able to identify in advance potentially dangerous situations that can affect the integrity of the optical metro link, without resorting to complex and expensive phase-OTDR (Optical Time Domain Reflectometer) distributed solutions [3,4].

2. Experimental layout

the proposed experimental layout is shown in Fig. 1. A 32 km SMF fibre ring deployed in the city of Turin, Italy (belonging to one of the Italian FTTH operators), was used to prove the feasibility of metro fiber infrastructure for sensing purposes, e.g. for monitoring the structural integrity of the fiber itself. The proposed scheme is basically

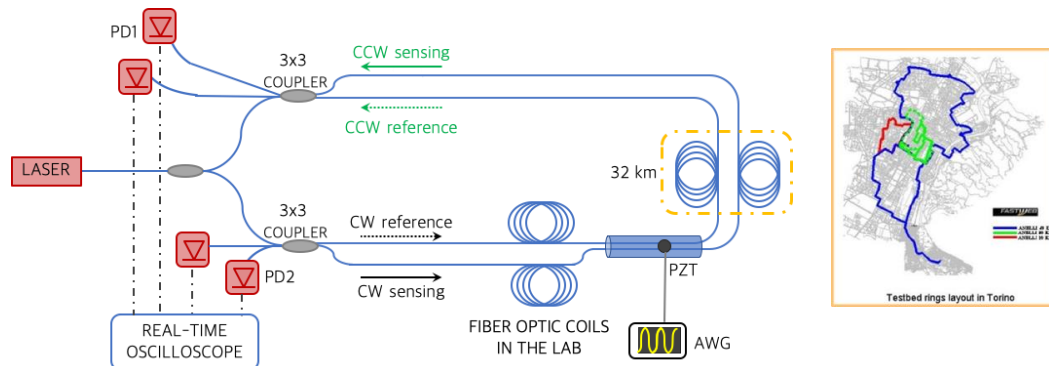

Fig1. Experimental layout

a dual Mach-Zehnderinterferometer arranged in a loop configuration, where counter-propagating continuous-wave optical signals travel along two fibers inside the same deployed optical cable [5].

The two fibers act as the sensing and reference arm of each interferometer. When a mechanical or acoustic vibration acts on the fiber loop, an additional phase modulation $\Delta\phi$ is generated in the optical signals, affecting the two signals propagating in the two opposite directions. Vibration localization is achieved by evaluating the time delay ΔT between the two counter-propagating phase modulated signals $\Delta\phi_{cw}$ and $\Delta\phi_{ccw}$ at the receivers. In particular, $\Delta\phi_{cw}$ and $\Delta\phi_{ccw}$ are separately retrieved by means of coherent receivers constituted by a simple 3x3 optical coupler providing the in-phase I and quadrature Q components of each interferometric signal [2]. The four optical signals are simultaneously detected by 125 MHz photoreceivers (NEP=25pW·√Hz), sampled by a 20 MS/s real-time oscilloscope (13bit) and post-processed to recover $\Delta\phi_{cw}$ and $\Delta\phi_{ccw}$ and evaluate the relative time delay ΔT [6]. Although the frequency band of mechanical and acoustic vibrations is in the order of kHz, 20 MS/s sampling rate is required to guarantee a 10-meter spatial resolution in event localization. We believe this is a good compromise between a reduced DSP complexity (20 MS/s can today be implemented on extremely cheap programmable electronic platforms) and a fault location spatial accuracy that is more than adequate in metro network anomalies location.

3. Vibration monitoring characterization and experimental results

Typically, in interferometric sensors the reference arm is separated from the measurement area. However, in the deployed fiber ring network exploited in this work the phase noise contributions caused by the city environment were sufficiently strong that it was chosen to have the reference and sensing arms along the same path. In this way, the common mode noise is reduced, at the expense of a reduction of the actual detected vibration signal. In our experiment, a 5 kHz vibration, generated by a PZT, was applied to the fiber cable to emulate a stress event. Fig. 2 shows the time behaviour and the spectral content of the recovered phase signal ϕ for the case of a 32 km reference fiber placed inside the lab compared to the configuration depicted in Fig.1 with reference and sensing fibers coupled in the same cable. The measurements highlight how the use of coupled fibers drastically reduces the integral noise accumulated along the link, while, at the same time, the slightest difference in the geometric arrangement of the fibers in the cable is sufficient to allow to reveal the vibration signal with a good SNR, thanks to the high sensitivity

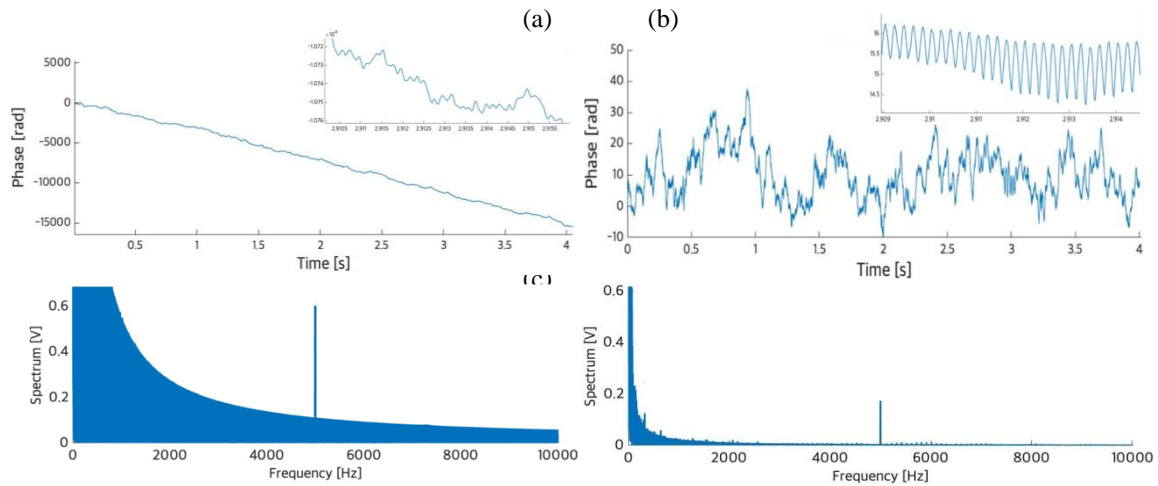

of coherent detection.

Fig2. Recovered phase signals in case of a) lab reference b) coupled fibers. Frequency spectra of the recovered phase signals in case of c) lab reference d) coupled fibers

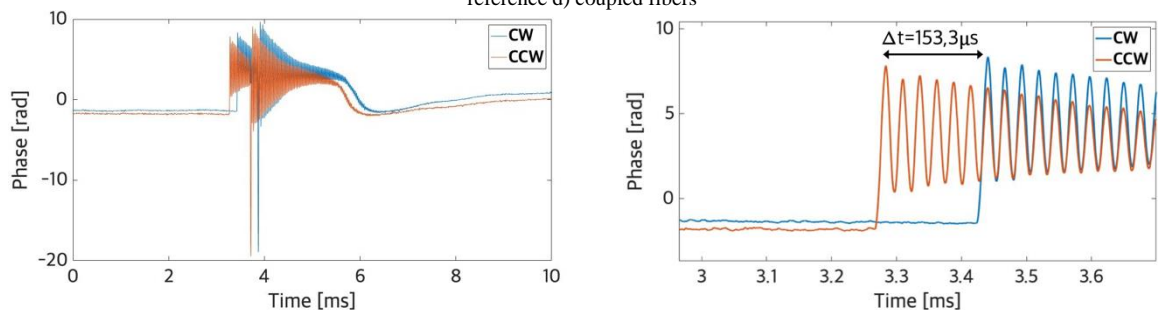

Fig3. Recovered $\Delta\phi_{cw}$ and $\Delta\phi_{ccw}$ signals in case of 1km fiber coil attached to the 32km fiber ring network.

Afterwards, by exploiting two coherent systems coupled in the counter-propagating configuration of Fig.1, we verified the possibility of localizing an impulsive dynamic event (e.g. an intrusion or a sudden damage). Different coil lengths, namely of 100 m, 1 km and 4 km were connected to one side of the deployed ring network and an impulsive event was generated with the PZT near the junction. The PZT was excited with square pulses of 450 μ s which in turn caused a natural damping response of the PZT itself. Fig. 3 shows the corresponding recovered signals $\Delta\phi_{cw}$ and $\Delta\phi_{ccw}$ measured for the case of a 1 km coil attached to the ring network, resulting in a delay $\Delta T=153,3$ μ s in agreement with a $\Delta L=31$ km (fiber refractive index $n=1.483$). Repeated measurements confirmed an accuracy of ± 15 m of the proposed approach in dynamic event localization.

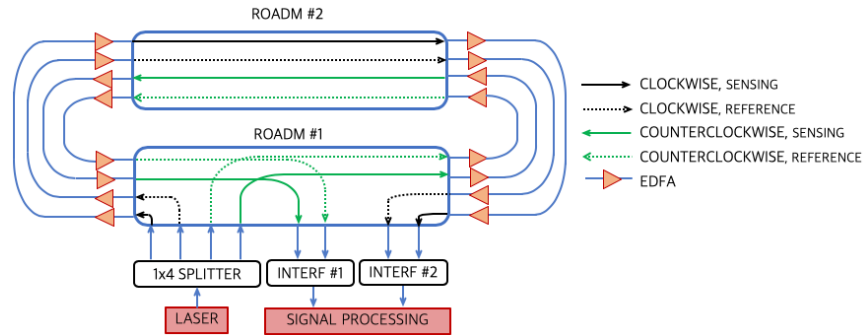

Fig 4. Extension of the proposed architecture in a ROADM-based ring network

4. Discussion for the implementation in a ROADM-based ring network and conclusions

In this paper we have shown and experimentally demonstrated over a 32-km fiber ring deployed in Turin city a coherent sensing solution, based on counter-propagating signals along the ring to detect and localize mechanical stress applied to the network cable. The capabilities in vibration monitoring are demonstrated, by exploiting an interferometric approach without complex and expensive phase-OTDR based techniques. The proposed sensing solution thanks to its ring topology and typical operation distances, is potentially suitable for modern metro ring networks, where distributed monitoring would be particularly interesting for early detection of anomalous conditions, that can induce damages or breakages of the fiber infrastructure. The experimented solution described in Fig.1 uses the two ring fibers in a bidirectional way. Today reconfigurable optical add-drop multiplexer (ROADM)-based dense wavelength-division multiplexed (DWDM) ring metro networks employ isolators in the optical amplifiers making each fiber path strictly mono-directional. To apply the same experimented sensing architecture, four mono-directional fiber paths are required (as shown in Fig. 4), exploiting two pairs of sensing and reference fibers (one pair for clockwise and one for counterclockwise propagation). The architecture in Fig. 4 would dedicate to sensing only one wavelength (in each of the four paths), leaving all the other wavelengths (not shown in the Figure for the sake of clearness) in the DWDM comb available for the normal data traffic transmission and routing inside the metro ring.

5. Reference

- [1] http://home.deib.polimi.it/maier/ro_PON_0910_v01.pdf
- [2] I. Di Luch, et al.: "Demonstration of Structural Vibration Sensing in a Deployed PON Infrastructure", Proceedings of ECOC2019, W.1.E.2
- [3] A. Glenn, et al.: "First field trial of sensing vehicle speed, density and road conditions by using fibre carrying high speed data", OFC, 2019, Th4C.7
- [4] P. Jousset, et al.: "Dynamic strain determination using fibre-optic cables allows imaging of seismological and structural features", Nature Communications, 2018, 9, article n°: 2509
- [5] X. Hong, et al.: "Dual Michelson Interferometers for Distributed Vibration Detection", Applied Optics, Vol. 50, 22, pp.4333-4338 (2011)
- [6] J. Morosi, et al.: "Coherent Fiber Optic Sensor for Vibration Localization", Fotonica AEIT Italian Conf. on Photonics Technologies, 2014