

A novel measurement method for accurate heat accounting in historical buildings

*Original*

A novel measurement method for accurate heat accounting in historical buildings / Dell'Isola, M.; Ficco, G.; Di Pietra, B.; Saba, F.; Masoero, M. C.. - In: MEASUREMENT. - ISSN 0263-2241. - 161:(2020), p. 107876.  
[10.1016/j.measurement.2020.107876]

*Availability:*

This version is available at: 11583/2819592 since: 2020-05-05T13:39:13Z

*Publisher:*

Elsevier

*Published*

DOI:10.1016/j.measurement.2020.107876

*Terms of use:*

This article is made available under terms and conditions as specified in the corresponding bibliographic description in the repository

*Publisher copyright*

(Article begins on next page)

[Click here to view linked References](#)

# A novel measurement method for accurate heat accounting in historical buildings

M. Dell'Isola<sup>1</sup>, G. Ficco<sup>1</sup>, B. Di Pietra<sup>2</sup>, F. Saba<sup>3</sup>, M.C. Masoero<sup>4</sup>

<sup>1</sup> DICeM, Department of Civil and Mechanical Engineering, University of Cassino and Southern Lazio, Via Di Biasio 43, 03043 Cassino, Italy. ph. +39 (0)7762993666, fax +39 (0)7762994002, email: dellisola@unicas.it

<sup>2</sup> ENEA - Dipartimento Unità per l'Efficienza Energetica (DUEE) - Via Anguillarese, km 1.150 - 00123 Roma, Italy

<sup>3</sup> INRIM Istituto Nazionale di Ricerca Metrologica, Strada delle Cacce 91, Torino, Italy

<sup>4</sup> DENERG -Dipartimento Energia, Politecnico di Torino, Corso Duca degli Abruzzi, 24 - 10129 Torino. Italy

**Abstract** – Nowadays, two different heat accounting methods are available: the direct method, based on heat meters, and the indirect one, based on heat cost allocators. Unfortunately, in existing buildings, due to the plant configuration, heat meters are often technically unfeasible or not cost efficient, whereas heat cost allocators can be easily installed in almost all conditions. At the same time, the indirect method relies on a high number of interconnected devices with installation and operative conditions often variable within the same building and influencing the on-field metrological performances. In this paper, the authors propose a novel “hybrid” method for accurate heat accounting combining the advantages of indirect method with the higher accuracy typical of direct methods. The proposed method has been experimented at INRIM, the primary metrology institute in Italy, assessing the on-field performance in a virtual eight-apartments building. The experimental results show that the proposed method always presents improved accuracy.

**Keywords:** heat accounting, heat meter, heat cost allocator, accuracy, historical buildings.

## 1. Introduction

The Energy Efficiency Directive (EED) 2012/27/EU [1] and its subsequent recast 2018/844/EU [2] identified individual heat accounting as an essential tool for improving energy efficiency in buildings.

32 To this aim, EED has set the obligation to install heat accounting systems for individual measurement  
33 of energy consumption of space heating in condominium buildings supplied by district heating or by a  
34 common centralized system, when technically feasible and economically convenient. Heat accounting  
35 methods can be classified into two main categories: i) direct methods, which provide through heat  
36 meters (HM) [3] an accurate measurement of the thermal energy consumed by each apartment within a  
37 building through an energy balance on the flow and return pipes of the heating/cooling circuit; ii)  
38 indirect methods, which provide estimates proportional to the heat exchanged between single heating  
39 elements and ambient of each apartment through dimensionless allocation units (*AU*). To this last  
40 category belong the heat cost allocators (HCA) [4] and the insertion time counters compensated with  
41 the heating fluid temperature [5] or with the degree days [6]. HMs are the most accurate devices  
42 currently available on the market for thermal energy measurement presenting also the peculiarity of  
43 being regulated by legal metrology MID directive [7] thus providing specific guarantees and consumer  
44 protection in terms of type approval, production, installation, initial and periodic verifications [8]. HMs  
45 are among the most used in new buildings, generally provided with central heating system and  
46 horizontal distribution configuration with manifolds for single apartments [9]. HCAs, on the other  
47 hand, are the most popular and widely used indirect accounting systems in northern and central  
48 European countries (such as Germany, Austria, Denmark). Besides, there is a huge theoretical potential  
49 for installation in existing buildings also in other European countries (estimated at around 20 million)  
50 such as Spain, France and Italy. In particular, in Italy the estimated multi-family buildings stock where  
51 individual measurement systems are not yet installed, is approximately 4.5 million [10].

52 The EED directive allows indirect heat accounting methods to be used when the direct one is not  
53 technically feasible and/or economically efficient. As a matter of fact, in many historical buildings, due  
54 to architectural constraints and/or to the configuration of the heating system (generally with vertical  
55 raising mains), direct HMs are not always technically feasible or cost efficient. In this case, in fact, it  
56 would be necessary to install one HM for each heating element, with consequent metrological issues  
57 due to low flow-rates and measured temperature differences in addition with unavoidable higher costs.  
58 In Europe, this is a typical situation in almost all historical buildings and in buildings built before the  
59 1980s [9, 11]. Unfortunately, not all heat accounting systems show the same reliability. Besides,  
60 indirect accounting systems show lower measurement accuracy which is extremely dependent on  
61 installation and programming features. A specific methodology for estimating the accuracy and  
62 reliability of indirect heat accounting systems is still lacking in the scientific literature and technical  
63 standards. Moreover, due to the specific architecture of such systems (that is to say a sort of complex

64 distributed system consisting of a large number of similar devices installed on radiators together with  
65 data gathering/storage/processing devices), the accuracy of heat allocation will depend on both the  
66 accuracy of the individual devices and on the different installation and operation characteristics of the  
67 plant. From a field analysis on the different heat metering and accounting methods [12] in fact,  
68 different accuracy levels have been found, ranging from about 4.4% for HMs to 21.6% for insertion  
69 time counters compensated with degree-days. Intermediate accuracy, on the other hand, were estimated  
70 for HCAs (about 9.2%) and for the insertion time counters compensated with the heating fluid  
71 temperature (about 13.4%). In reality, the accuracy of indirect accounting systems in different  
72 operating conditions may vary from about 2.7% (i.e. in a large multi-family building in optimal  
73 conditions) to about 11.7% (i.e. in a two-family building in critical conditions). Furthermore, the  
74 allocation accuracy can be estimated through a model allowing to assess the influence of the  
75 installation conditions with particular reference to the number and type of radiators and of the related  
76 installation, also in relation to the installation issues and use of single apartments. This model can be  
77 adopted both to design appropriate heat accounting systems in new buildings and to evaluate their  
78 reliability in existing ones. [13].

79 In this work, aiming at addressing the above mentioned issues of accounting methods in existing  
80 buildings with a centralized heating system, especially for large buildings and occasionally lived, the  
81 authors propose a novel accounting method, namely the "hybrid heat accounting" method. The  
82 proposed method relies on indirect systems on single radiators and on direct heat meters on the existing  
83 raising mains of the heating plant, merging the advantages of direct and indirect allocation methods. In  
84 particular, in respect to the actual available heat accounting methods such as proportional methods  
85 based on floor area or installed heat power or indirect HCAs, it allows knowing the consumption of  
86 each room in the apartment typical of indirect methods and it is expected to show an increasing  
87 accuracy and reliability of the share typical of direct methods. The metrological performance of the  
88 proposed method was analysed at the experimental mockup of INRIM, the National Metrological  
89 Research Institute of Turin, specifically configured to simulate field operation of an eight apartments  
90 building. Through a specific design of the experiments, it was possible to assess the influence of some  
91 operating parameters such as: i) the usage mode (occasional or continuous) by excluding some  
92 apartments; ii) the different consumption due to changes in the external climatic conditions through the  
93 variation of the heating fluid flow and temperatures.

94

95

96 **2. Theory and Methods**

97

98 The direct heat accounting method allows accurate measurement of the energy supplied to each  
99 apartment, at the same time showing generally high commissioning costs and above all an intrinsic  
100 limitation of use in buildings with vertical distribution. On the other hand, the heat accounting method  
101 does not directly measure the energy consumed but estimates dimensionless allocation units  
102 proportional to it, presenting a lower accuracy together with simpler installation and basically lower  
103 costs. Furthermore, indirect methods allow to discriminate the consumption of each emission element  
104 and therefore of each room within the apartment. Figure 1 shows the two typical operational schemes  
105 of distributed heating plants in existing condominium buildings supplied by a common centralized  
106 system. In ring distribution plants direct heat accounting with HMs is in principle technically feasible,  
107 whereas in vertical mains distribution ones only indirect accounting systems combine technical  
108 feasibility and economic convenience.

109

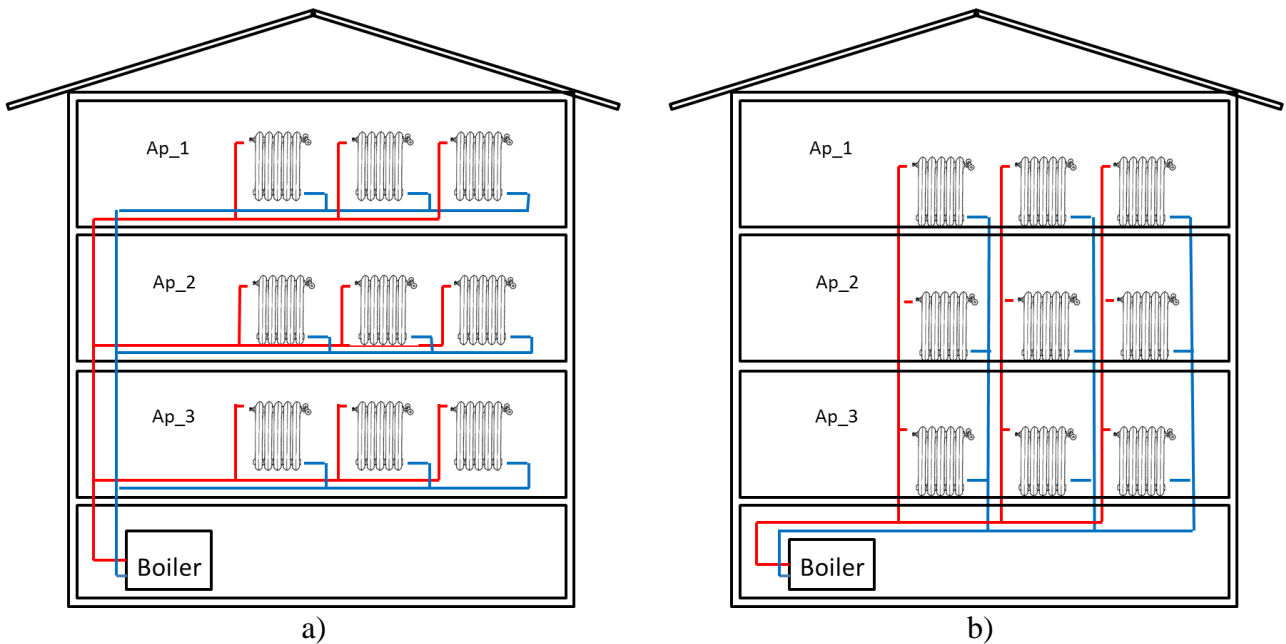

110 Figure 1 – Heating plant configurations of distributed heating plants: a) Ring distribution, b) Vertical  
111 mains distribution  
112

113

114 2.1 Direct and indirect heat accounting methods

115

116 When a direct heat accounting method is applied, the "individual" share of single apartments,  $S_i$  (%), is  
 117 estimated by calculating the ratio between the energy consumed by the single apartment (measured  
 118 through HMs used as sub-meters),  $Q_i$  (kWh), and the total energy consumed in the building,  $Q_b$  (kWh),  
 119 and measured by a supply thermal energy meter (e.g. through a HM in the heat exchange substation in  
 120 the case of supply from district heating, or the energy measured by a gas meter if the boiler is supplied  
 121 by natural gas network), as per equation (1).

$$S_i = \frac{Q_i}{Q_b} \quad (1)$$

122 On the other hand, for indirect heat accounting methods, the allocation unit of the  $i$ -th apartment of the  
 123 building ( $AU_i$ ), is obtained by summing the allocation unit of each  $j$ -th radiator in the apartment ( $AU_{i,j}$ ),  
 124 as per eq.(2). Then, the share  $S_i$  of each  $i$ -th apartment (i.e. the so-called "voluntary" heat  
 125 consumptions) is given by the following equation (3).

$$AU_i = \sum_{j=1}^{n_j^i} AU_{i,j} \quad (2)$$

$$S_i = \frac{AU_i}{AU_b} = \frac{\sum_{j=1}^{n_j^i} AU_{i,j}}{\sum_{i=1}^{n_i} \sum_{j=1}^{n_j^i} AU_{i,j}} \quad (3)$$

126 where  $n_j^i$  is the number of radiators (which is usually equal to the number of columns in the heating  
 127 plant) in each  $i$ -th apartment and  $n_i$  is the number of apartments in the building, respectively.

128

## 129 2.2 The novel "hybrid heat allocation" method

130

131 The novel hybrid allocation method has been developed at the LAMI, the industrial measurement  
 132 laboratory of the University of Cassino and Southern Lazio, and consists of indirect heat accounting  
 133 devices (e.g. HCAs) installed on each radiator and direct HMs installed at the base of each raising main  
 134 of the heating distribution plant in addition to the supply HM, as shown in Figure 2.

135

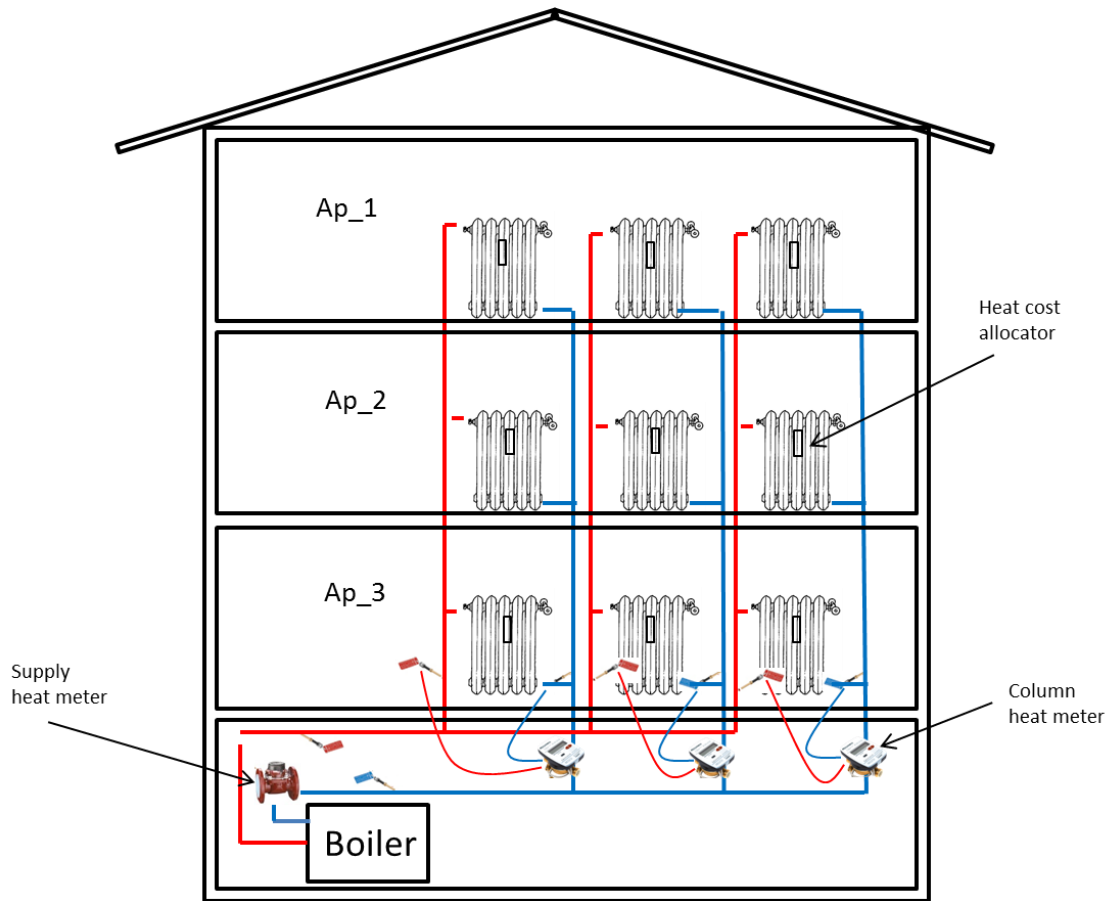

Figure 2 – Hybrid heat allocation method scheme

136

137

138

139

140 The possibility of improving the metrological performance of indirect accounting devices in buildings  
 141 supplied by centralized heating plant with vertical raising mains was first proposed by Celenza et al.  
 142 [9]. In this case, heat allocation is carried out selectively on each column and not on the entire building,  
 143 also allowing in this way:

- 144 – to verify the thermal energy produced by the boiler and, therefore, to monitor its efficiency and  
 145 promptly schedule eventual maintenance interventions;
- 146 – to evaluate the individual share of heat consumption, considering groups of radiators with  
 147 similar installation conditions and nominal heat output, like the radiators on each vertical  
 148 raising main; indeed, the apartment typology and the rooms distribution is typically repetitive  
 149 for the overlapping floors, thus, higher accuracy of the accounting is expected as a positive  
 150 effect of the compensation of the similar systematic errors affecting the indirect heat accounting  
 151 devices;

- 152 – to monitor the energy consumption of single rooms, maintaining at the same time the energy  
 153 measurement on each column;
- 154 – to show the economy and simplicity of installation of indirect devices with a slight additional  
 155 cost depending on the number of vertical raising mains. For example, in a ten-story building  
 156 with 20 apartments and 100 heating elements with a heating distribution system with 5 columns  
 157 (i.e. needing the installation of 5 HMs additional to the indirect system) the increase of fixed  
 158 cost for commissioning would be about 15-20%.

159 The direct measurement on the vertical raising mains returns the values of the thermal energy  $Q_k$  (kWh)  
 160 supplied along each vertical  $k$ -th and therefore the total one of the building as per eq.(5). Allocation  
 161 unit  $AU'_{i,j}$  of each radiator in the hybrid method is then given by eq. (6).

$$Q_b = \sum_{k=1}^{n_k} Q_k \quad (5)$$

$$AU'_{i,j} = AU_{i,j} \frac{AU_b}{AU_k} \frac{Q_k}{Q_b} = AU_{i,j} \frac{\sum_{i=1}^{n_i} \sum_{j=1}^{n_j^i} AU_{i,j}}{\sum_{j=1}^{n_j^k} AU_{i,j}} \frac{Q_k}{Q_b} \quad (6)$$

162 where  $n_k$  is the number of the vertical raising mains in the distribution plant,  $n_j^i$  is the number of  
 163 radiators in each  $i$ -th apartment and  $n_j^k$  is the number of radiators installed on each raising main.

164 For the sake of simplicity, it can be argued that a correction factor is introduced which depends on both  
 165 the ratio between the energy consumed in the single raising main ( $Q_{k,j}$ ) and the total in the building  
 166 ( $Q_b$ ) and between the total  $AU_b$  in the building and the  $AU_{k,j}$  in the single raising main.

167 Therefore, the share  $S'_i$ , of each  $i$ -th apartment (i.e. the so-called "voluntary" heat consumptions) is  
 168 given by the following equation:

$$S'_i = \frac{AU'_i}{AU'_b} = \frac{\sum_{j=1}^{n_j^i} AU'_{i,j}}{\sum_{i=1}^{n_i} \sum_{j=1}^{n_j^i} AU'_{i,j}} = \frac{\sum_{j=1}^{n_j^i} \left( \frac{AU_{i,j}}{\sum_{j=1}^{n_j^k} AU_{i,j}} \frac{Q_k}{Q_b} \right)}{\sum_{i=1}^{n_i} \sum_{j=1}^{n_j^i} \left( \frac{AU_{i,j}}{\sum_{j=1}^{n_j^k} AU_{i,j}} \frac{Q_k}{Q_b} \right)} \quad (7)$$

169

170

171 2.3 Design of experiments

172

173 The authors designed an experimental campaign at the Energy Measurement Laboratory of INRIM, the  
174 National Metrology Institute of Turin, aimed at evaluating the performance of the novel hybrid  
175 accounting method. The test facility (Figure 3) consists of a full-scale central heating system with 40  
176 radiators characterized by different shapes, hydraulic connections, dimensions and materials, installed  
177 on four levels and connected through a hydraulic circuit which can be automatically set in order to  
178 simulate alternatively raising mains or single pipe horizontal distribution plant configuration.

179



180

181

182 Figure 3 - Heat accounting experimental mockup at INRIM

183

184 The test facility allows testing both conventional and innovative heat accounting systems and methods  
185 in experimental conditions similar to the operational ones [14, 15]. The experimental mockup has been  
186 configured with vertical raising main distribution, which is the typical application case of the indirect  
187 heat accounting through HCAs in historical buildings. Figure 4 shows the layout of the experimental  
188 mockup with the identification of the individual heating elements and vertical mains.

189

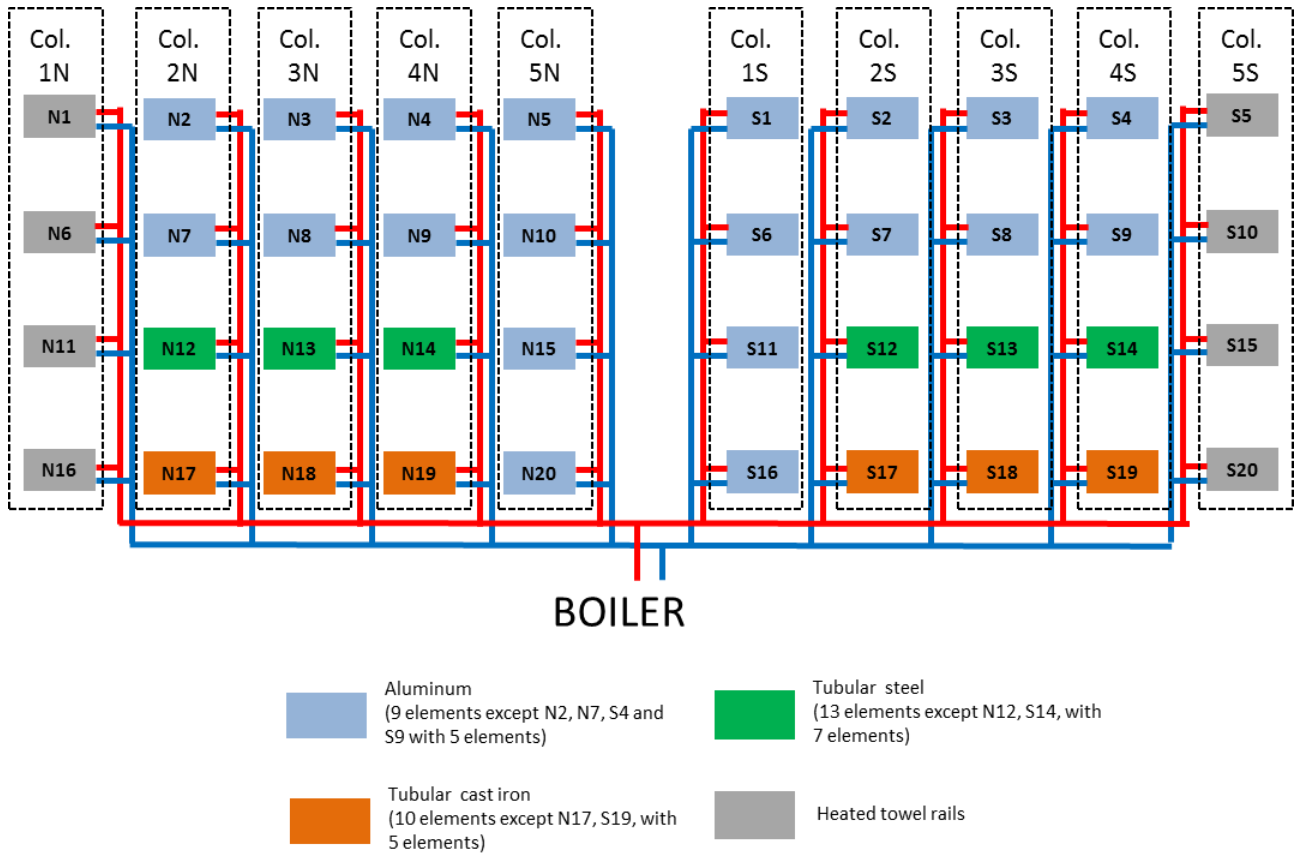

190

191

192 Figure 4 - INRIM mockup for heat accounting measurements with vertical raising main configuration

193

194 In Table 1 a summary of the technical characteristics of the radiators installed in the experimental  
 195 mockup is reported.

196

197

Table 1– Technical characteristics of the radiators of the experimental mockup

<i>Radiator type and id.</i>		<i>Number of radiator elements</i>	<i>Radiator Dimensions (H, L, W), mm</i>	<i>Nominal Heat output EN 442 [16, 17] <math>\Delta T_r = 50^\circ\text{C}, W</math></i>	<i>Radiator exponent (EN 442)</i>
Aluminum	N3, N4, N5, N8, N9, N10, N15, N20, S1, S2, S3, S6, S7, S8, S11, S16	9	720, 870, 80	1.36	1716
	N2, N7, S9, S4	5	400, 870, 80		973
Cast iron	N18, N19, S17, S18	10	600, 880, 140	1.37	2044
	S19, N17	5	300, 880, 140		1060
Steel	N13, N14, S12, S13	13	590, 900, 150	1.28	1908
	S14, N12	7	320, 900, 150		1073
Heated towel rail	N1, N6, N11, N16, S5, S10, S15, S20	-	535, 713, 30	1.25	496

198

199 To compare the performance of the novel hybrid method against a conventional indirect heat  
200 accounting method, 40 two-sensors electronic HCAs (EN 834 approved) have been installed on the  
201 mockup radiators and programmed according to the manufacturer's instructions. Reference data are  
202 provided by combined HMs made up of an electromagnetic flow meter, a pair of Pt100 resistance  
203 thermometers and a thermal energy calculation unit directly implemented on the central control PC,  
204 which receives the converted measurement signals from a Programmable Logic Controller (PLC).

205 The sub-assemblies of HMs are periodically calibrated at the INRIM laboratories, guaranteeing the  
206 necessary metrological traceability to the national standards. In particular:

- 207 – electromagnetic flow meters are calibrated by comparison with a reference electromagnetic  
208 flow meter (which is in turn calibrated against the national standard of liquid flow rate), on at  
209 least five flow rate values, automatically configuring the hydraulic circuit so that the flow  
210 meters of single radiators are in series with the reference meter;
- 211 – temperature sensors are calibrated by comparison with a reference Pt100 resistance  
212 thermometer in a thermostatic bath.

213 The entire system is monitored and controlled by means of a SCADA-HMI software, through which it  
214 is possible to vary the working points of the centralized generator, the circulation pump and the  
215 opening and closing states of the valves of each heating body, intervening both manually and  
216 automatically according to a predetermined program. Thus, it is possible to adjust the flow temperature  
217 and the flow rate of the heat transfer fluid in each radiator. Furthermore, through the automatic system,  
218 the output signals of the reference direct heat meters (power, thermal energy, flow rate, inlet and outlet  
219 temperatures) can be logged with a sampling interval of at least 15 s.

220 With the aim to reproduce as far as possible the typical installation and operational conditions on the  
221 field, the experimental mockup has been configured as a virtual four-storeys / eight-apartments  
222 building (Figure 5). Each virtual floor consists of two apartments: a two-room apartment with four  
223 radiators (apartments 1, 3, 5 and 7) and a four-room apartment with six radiators (apartments 2, 4, 6  
224 and 8). Therefore, the centralized heating plant presents ten vertical raising mains. The four vertical  
225 raising mains of the two-room apartments are characterized by identical radiators with the same heat  
226 output, whereas the six vertical raising mains of the four-room apartments consist of radiators of  
227 different type, but similar nominal heat output.

228

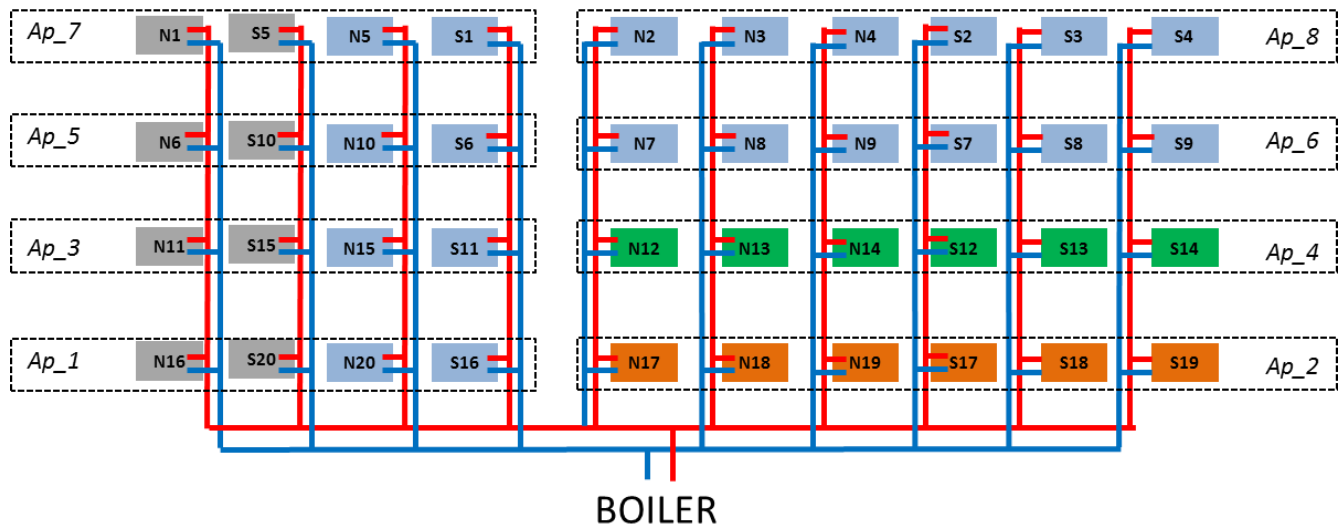

229  
230

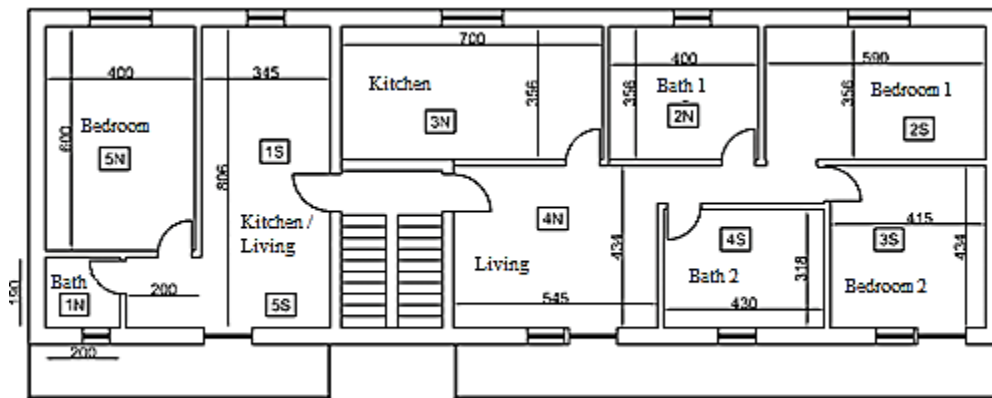

231  
232  
233

Figure 5 – Experimental set-up and corresponding virtual building

234 The authors also performed the calculation of the thermal energy need and the related radiators nominal  
 235 heat output of the virtual building, considering the requirements of the climatic zone “E” where the  
 236 INRIM experimental mockup is located. For such a climatic zone, the heating period is between  
 237 October 15<sup>th</sup> and April 15<sup>th</sup> for a maximum daily operation of 14 hours. The indoor temperature of the  
 238 heated rooms and the minimum outdoor temperature in the winter period have been conventionally set  
 239 at 20°C and -8°C, respectively. Based on such design data and on the nominal heat output of each  
 240 radiator of the mockup, the virtual test rooms to which each radiator is associated have been identified.  
 241 Consequently, three different climatic periods of the heating season from October 15<sup>th</sup> to April 15<sup>th</sup>  
 242 were identified for which the average temperatures of Turin and the corresponding heat requirements

243 for each room have been calculated, as well as the heat output and heating fluid flow-rates, assuming a  
244 temperature difference between supply and return of about 10 °C (see table 3).

245 In order to evaluate the performance of the novel hybrid accounting method in test conditions close to  
246 the real dynamic operating conditions, the experiments were designed considering [18]:

- 247 – three different combinations of total flow rate and supply temperature of the heating plant,  
248 simulating the real operation of the system in three periods of the heating season (namely “warm”,  
249 “cold” and “very cold”) characterized by different average outdoor temperatures (13 °C, 6.5 °C and  
250 0 °C, respectively);
- 251 – different time programmed heating load profiles, consisting of an initial phase of variable duration  
252 (from 30 min to 90 min) in which the heater is set at its peak load (time duration and peak heating  
253 power depend on the simulated period of the heating season), followed by a steady mode heating  
254 phase of 4 hours and a final cooling phase of about 2 hours for radiators surface cooling down to the  
255 indoor ambient temperature (each heating profile has been repeated four times consecutively);
- 256 – different combinations of open and closed radiators, simulating different occupational modes of the  
257 building and usage of the heating plant (tests have been carried out both with all radiators open and  
258 with the radiators of some apartments alternatively closed).

259 The test conditions for the evaluation of the performance of the novel hybrid accounting method are  
260 summarised in table 2.

261

262

Table 2 – Test conditions

<i>Period</i>	<i>Start</i>	<i>End</i>	<i>Av. outdoor temp.</i>	<i>Transient</i>	<i>Occupancy conditions</i>
Warm	October 15 <sup>th</sup>	November 15 <sup>th</sup>	13 °C	30 min	All apartments occupied
	March 15 <sup>th</sup>	April 15 <sup>th</sup>	13 °C		Ap_7 and Ap_8 not occupied
Cold	November 15 <sup>th</sup>	December 15 <sup>th</sup>	6,5 °C	60 min	All apartments occupied
	February 15 <sup>th</sup>	March 15 <sup>th</sup>	6,5 °C		Ap_3 and Ap_4 not occupied
Very cold	December 15 <sup>th</sup>	January 15 <sup>th</sup>	0 °C	90 min	All apartments used
	January 15 <sup>th</sup>	February 15 <sup>th</sup>	0 °C		Ap_3, 4, 7 and 8 not occupied

263

264

265 **4. Uncertainty estimation of heat accounting hybrid method**

266

267 **4.1 Uncertainty estimation of reference thermal energy measurement and of the allocation units**

268

269 The uncertainty estimation of the reference thermal energy measurements is carried out considering the  
270 measurement model given by the energy conservation law [19]:

$$Q = \int \rho \dot{V} c_p \Delta T_{io} dt \quad (8)$$

271 where  $\rho$  and  $c_p$  are, respectively, the density and the specific heat capacity of the heat conveying fluid  
272 (water),  $\Delta T_{io}$  is the temperature difference between the inlet and outlet flow section of the radiator,  $\dot{V}$  is  
273 the radiator volumetric flow rate and  $t$  is the time. Thus, applying uncertainty the propagation law and  
274 considering the measurement quantities are not correlated, standard uncertainty of the reference  
275 thermal energy measurement can be evaluated approximately as:

$$u(Q) \cong Q \sqrt{\left[\frac{u(\dot{V})}{\dot{V}}\right]^2 + \left[\frac{u(\Delta T)}{\Delta T}\right]^2 + \left[\frac{u(\rho)}{\rho}\right]^2 + \left[\frac{u(c_p)}{c_p}\right]^2} \quad (9)$$

276 The relative uncertainties of density and specific heat capacity of the heat conveying liquid (water)  
277 have been evaluated taking into account the uncertainty contributions of water temperature and  
278 pressure measurements, the uncertainty of the equation of state for the determination of the  
279 thermodynamic properties of water [20] and, finally, the uncertainty of density and specific heat  
280 capacity measurements. The uncertainty contribution of the time integration of radiator thermal power  
281 is assumed to be negligible compared to the other contributions. In table 3 a summary of the single  
282 uncertainty contributions of the HMs sub-assembly modules installed on each radiator has been  
283 reported together with the estimation of the reference thermal energy measurement.

284

285

Table 3 –Uncertainty estimation of the reference thermal energy measurement

<i>HM sub-assembly</i>	<i>Sensor</i>	<i>Standard uncertainty</i>
Flow measurement	Electromagnetic flow meter	0.1% of reading for flow-rates higher than 90 dm <sup>3</sup> h <sup>-1</sup> from 0.1% to 1.0% of reading for flow-rates in the range from 90 dm <sup>3</sup> h <sup>-1</sup> to 20 dm <sup>3</sup> h <sup>-1</sup>
Flow / return temperature difference	Pair of Pt100 resistance thermometers and PLC module for 4-wire resistance measurement	0.04 °C
Calculation of heating fluid thermodynamic properties and time integration of thermal power measurement	Calculation unit implementing approximated formulations of the fluid equation of state	1.0% (with respect to the calculated product between density and specific heat capacity of the fluid)
Standard uncertainty of reference thermal energy measurement		from 0.8 to 2.7 % of reading

287

288 The uncertainty of  $AU$  counted by HCAs has been evaluated considering the following contributions: i)  
 289 the display resolution (i.e.  $R_{AU} = 1$ ), ii) the maximum relative display deviation (i.e.  $E\%_{max} = \pm 5\%$   
 290 in the range of  $15 K \leq \Delta T \leq 40 K$  [4]) and iii) the uncertainty of the estimation of rating factor  $K_Q$   
 291 related to the heat output of radiators (according to EN 442 [16, 17]). The uncertainty of  $AU'$  of hybrid  
 292 method can be considered equal to the indirect method, since the uncertainty contribution of the direct  
 293 thermal energy measurements (heat meters) is negligible with respect to the uncertainty of HCAs.  
 294 Therefore, the standard uncertainty  $u(AU)$  can be evaluated as follows:

$$u(AU) = u(AU') \cong AU \sqrt{2 \left( \frac{R_{AU}}{AU \cdot 2\sqrt{3}} \right)^2 + \left( \frac{E\%_{max}}{\sqrt{3}} \right)^2 + u(K_Q)^2} \quad (10)$$

295

296

#### 297 4.2 Uncertainty estimation of the Share

298

299 The uncertainty of the share obtained through the reference thermal energy measurements at each  
 300 radiator, can be evaluated approximately as:

$$u(S_{HM,i}) \cong S_{HM,i} \sqrt{\left[ \frac{u(Q_i)}{Q_i} \right]^2 + \left[ \frac{u(\sum_1^n Q_j)}{\sum_1^n Q_j} \right]^2 - 2 \frac{cov(Q_i, \sum_1^n Q_j)}{Q_i \sum_1^n Q_j}} \quad (11)$$

301 where the uncertainty of the heat consumption of individual apartments  $u(Q_i)$  is evaluated assuming that  
 302 thermal energy measurements of radiators belonging to the same apartment (i.e. radiators on the same floor)  
 303 are fully correlated. On the other hand, the uncertainty of the overall sum of heat consumptions is  
 304 obtained considering a null correlation between thermal energy measurements of different apartments  
 305 (null correlation between radiators on different floors):

$$u\left(\sum_1^n Q_j\right) \cong \sqrt{\sum_1^n u^2(Q_j)} \quad (12)$$

306 Under the same assumption of uncorrelated thermal energy measurements of single apartments, the  
 307 covariance between a single apartment and the overall heat consumption can be evaluated as:

$$\text{cov}\left(Q_i, \sum_1^n Q_j\right) \cong u^2(Q_i) \quad (13)$$

308 Similarly, the uncertainty of the share obtained through the indirect and the hybrid method, can be  
 309 evaluated as follows:

$$u(S_i) \cong S_i \sqrt{\left[\frac{u(AU_i)}{AU_i}\right]^2 + \left[\frac{u(\sum_1^n AU_j)}{\sum_1^n AU_j}\right]^2 - 2 \frac{\text{cov}(AU_i, \sum_1^n AU_j)}{AU_i \sum_1^n AU_j}} \quad (14)$$

$$u\left(\sum_1^n AU_j\right) \cong \sqrt{\sum_1^n u^2(AU_j)} \quad (15)$$

$$\text{cov}\left(AU_i, \sum_1^n AU_j\right) \cong u^2(AU_i) \quad (16)$$

310

311

312 **4. Results and discussions**

313

314 Table 4 shows the experimental results for the whole investigated period in terms of heat allocation  
 315 units and shares of each apartment. Heating shares are calculated from the HCAs readings by applying  
 316 the conventional indirect method and the novel hybrid method and from the reference direct direct  
 317 method (i.e. through thermal energy meters). The values of indirect and hybrid shares and the  
 318 corresponding errors estimated over the entire test period with respect to the reference direct method  
 319 are also reported.

320 The analysis of results in Table 4 highlighted hybrid method shows a lower maximum absolute error  
 321 (i.e. 1.35% against 2.06%) and a standard deviation of accounting errors equal to 1.22% and 0.89% for  
 322 the indirect and hybrid methods, respectively. In table 4 the measured errors have been discriminated  
 323 at building (i.e. the difference between the calculated share and the one of the reference direct method)  
 324 and at apartment level (i.e. the ratio between this latter and the share of the reference direct method).  
 325 Single errors, although they may appear small if compared to the whole accounting in the building  
 326 (absolute errors), become extremely relevant when compared with the shares charged to each user  
 327 (relative errors). As for example Ap\_1 and Ap\_4 would pay respectively 15.1 % less and 10.6% more  
 328 through the indirect method in respect to the reference direct one, and such difference is smoothed with  
 329 the proposed hybrid method (i.e. 7.9% less and 6.4% more, respectively). The experimental results  
 330 show that the proposed hybrid method leads to a significant improvement in the accuracy of heat  
 331 accounting compared to the indirect one both in terms of standard deviation, weighted mean square  
 332 error (*wRMSE*) and maximum errors.

333

334 Table 4 – Experimental results for the whole investigated period

	<i>Direct method</i>		<i>Indirect method</i>				<i>Hybrid method</i>			
	<i>Q / kWh</i>	<i>S<sub>HM</sub></i>	<i>AU</i>	<i>S</i>	<i>Error (building)</i>	<i>Error (apartment)</i>	<i>AU'</i>	<i>S'</i>	<i>Error (building)</i>	<i>Error (apartment)</i>
Ap_1	429.38	11.83%	299	10.04%	-1.79%	<b>-15.1%</b>	324.54	10.90%	-0.93%	<b>-7.9%</b>
Ap_2	824.92	22.73%	738	24.78%	<b>2.06%</b>	9.0%	710.58	23.86%	1.14%	5.0%
Ap_3	222.06	6.12%	178	5.98%	-0.14%	-2.3%	193.34	6.49%	0.37%	6.1%
Ap_4	502.78	13.85%	456	15.31%	1.46%	10.6%	439.02	14.74%	0.89%	6.4%
Ap_5	352.73	9.72%	273	9.17%	-0.55%	-5.7%	295.95	9.94%	0.22%	2.3%
Ap_6	665.09	18.32%	525	17.63%	-0.69%	-3.8%	505.50	16.97%	<b>-1.35%</b>	-7.4%
Ap_7	212.36	5.85%	171	5.74%	-0.11%	-1.8%	184.20	6.19%	0.34%	5.7%
Ap_8	420.63	11.59%	338	11.35%	-0.24%	-2.1%	324.87	10.91%	-0.68%	-5.9%
Total	3630.0	100.0%	2978	100.0%	0.00%	-	2978.0	100.0%	0.00%	-

335 Note: The maximum absolute errors have been evidenced in bold

336 Table 5 summarizes the results for the indirect and hybrid methods of the tests at different climatic (i.e.  
 337 warm, cold, very cold) and occupancy conditions (i.e. full/not full occupancy) in terms of maximum  
 338 error and of Root-Mean-Square-Error weighted with the estimated uncertainties of the errors  
 339 ( $wRMSE$ ), calculated as per eq.(17):

$$wRMSE = \sqrt{\frac{\sum_i [E_i / U(E_i)]^2}{\sum_i [1 / U(E_i)]^2}} \quad (17)$$

340 where the errors of the shares  $E_i$  for hybrid and indirect methods and the expanded uncertainty of  
 341 errors,  $U(E_i)$ , with a coverage factor  $k=2$  which for a normal distribution corresponds to a probability  
 342 of approximately 95%, have been evaluated as follows.

$$E_i = S_i - S_{HM,i} \quad (18)$$

$$U(E_i) = 2 \sqrt{u^2(S_{HM,i}) + u^2(S_i)} \quad (19)$$

343

344

Table 5 –  $wRMSE$  at different climatic conditions and occupancy

Period and Occupancy conditions		$wRMSE$ , %			Maximum error, %		
		Indirect	Hybrid	Improvement	Indirect	Hybrid	Improvement
Full occupancy	Warm	1,21	0,95	-21,8 %	2.50	1.51	-39.6 %
	Cold	0,93	0,82	-12.0 %	2.04	1.48	-27.3 %
	Very Cold	0,81	0,54	-33,6 %	1.64	0.96	-41.5 %
	Whole full occ. period	0,94	0,72	-23,4 %	1.95	1.23	-36.9 %
Occasional occupancy	Warm,	1,35	0,96	-29,1 %	2.53	1.41	-44.3 %
	Cold	1,30	1,02	-21,5 %	3.69	2.69	-27.0 %
	Very Cold,	1,83	1,31	-28,3 %	2.36	1.53	-35.2 %
	Whole occasional occ. period	0,55	0,44	-19,9 %	2.78	1.63	-41.3 %
Whole period		0,84	0,65	-23,4 %	2.06	1.14	-44.7 %

345

346

347 From data in table 5 it can be highlighted that a reduction of both  $wRMSE$  and maximum error has  
 348 been found when the hybrid method is applied and that in the cold period at not full occupancy error  
 349 peaks of 3.69% for indirect method and 2.69% for hybrid one occur. Therefore, it is possible to state  
 350 that the hybrid method shows in average an accuracy of 1.14% which is much better than the  
 351 conventional indirect method one (equal to 2.06%). It is also interesting to highlight that the hybrid  
 352 method is particularly effective especially when occasional occupation conditions occur. In this case, in  
 353 fact, an improvement in accuracy from 2.78% to 1.63% has been found with respect to the maximum  
 354 error (and from 0.55% to 0.44% in terms of  $wRMSE$ ). In any case, the hybrid method was more  
 355 effective at all the investigated climatic and occupancy conditions.

356 Figure 6 and Figure 7 show a comparison between hybrid and indirect methods in terms of  $wRMSE$   
 357 and of maximum error, respectively. It can be highlighted that hybrid method shows better accuracy at  
 358 any climatic condition and both for full or not-full occupancy.  
 359

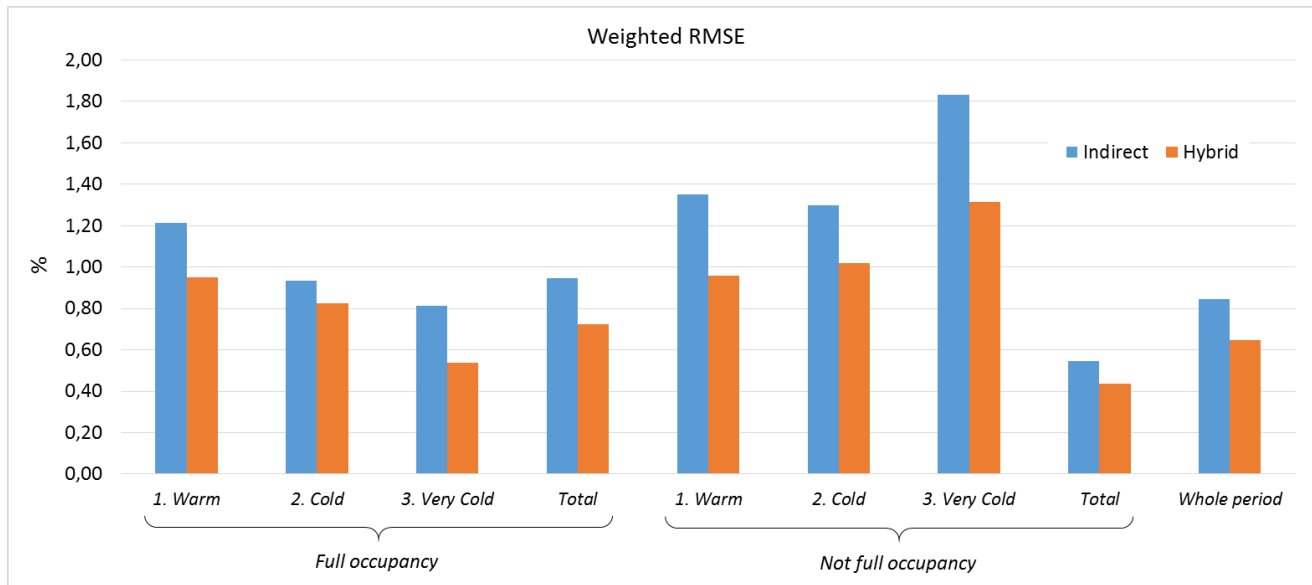

360  
 361 Figure 6 –  $wRMSE$  of indirect and hybrid methods  
 362

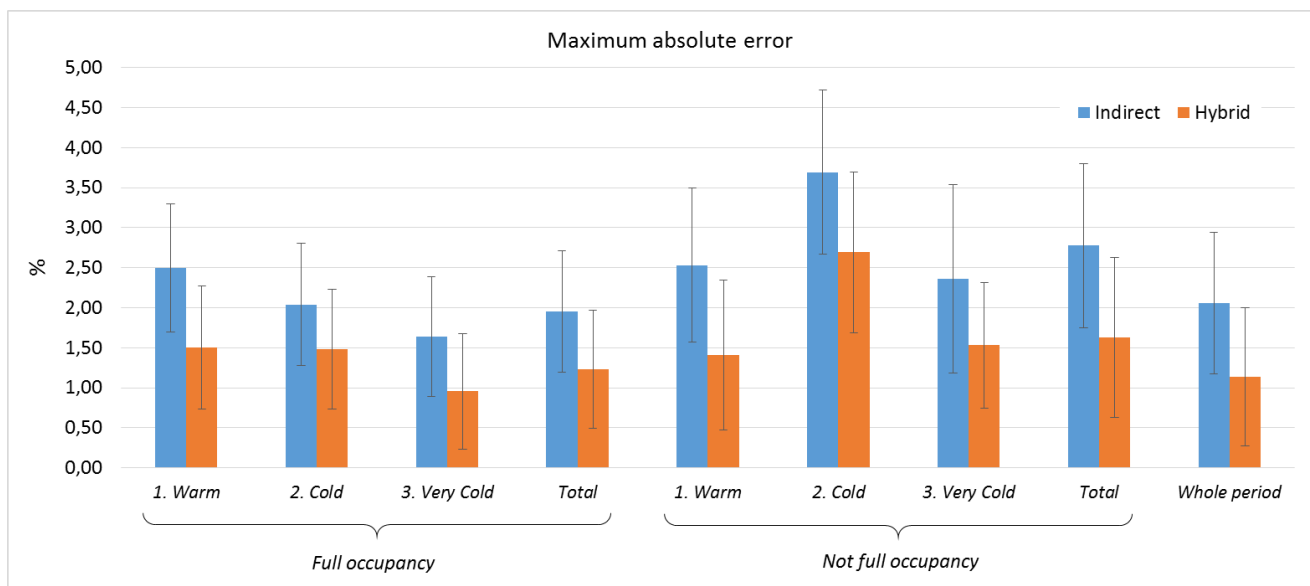

363  
 364 Figure 7 – Maximum error of indirect and hybrid methods  
 365

366 A tricky issue of indirect heat accounting systems, which can greatly affect their accuracy, is  
 367 represented by the estimation of rated heat output of single radiators. In particular, for two sensors

368 electronic heat cost allocators, which are nowadays the more spread indirect heat accounting systems, a  
 369 resulting rating factor  $K$  must be estimated. This is given by the product of  $K_C$  and  $K_Q$  rating factors,  
 370 which take into account the thermal contact between HCA and radiator surface and the nominal heat  
 371 output of the radiator, respectively. Furthermore, authors investigated the sensitivity of indirect and  
 372 hybrid methods when systematic errors of the estimation of rating factor  $K$  occur. In particular, the  
 373 estimation of  $K_Q$  is a particularly critical issue in the indirect method, especially in existing buildings  
 374 where rated heat output of heating bodies is not always known and certified [21]. To this end,  
 375 systematic fictitious errors (e.g. the possible errors associated to the initial HCA configuration by the  
 376 installer or consequent to a renovation of the thermal plant) were introduced in the heat output of  
 377 radiators and their effects have been evaluated. Figure 8 shows the dependence of standard deviation  
 378 and maximum error of heat accounting with respect to the error of coefficient  $K$  for radiators installed  
 379 in the same vertical raising main (which can be assumed equal to each other). This situation is fairly  
 380 common in buildings with standard apartment types in the different storeys and, therefore, with the  
 381 same configuration and installation leading to highly likely systematic errors (e.g. radiator with the  
 382 same few number of elements in the bathrooms, radiators installed in a niche in the wall, etc.). From  
 383 the analysis of the results it can be pointed out, as predictable, that the hybrid method shows a constant  
 384 accuracy and it is not affected in any way by the aforementioned error, whereas the indirect method  
 385 accuracy shows a linear dependence with the error of  $K$  coefficient.

386

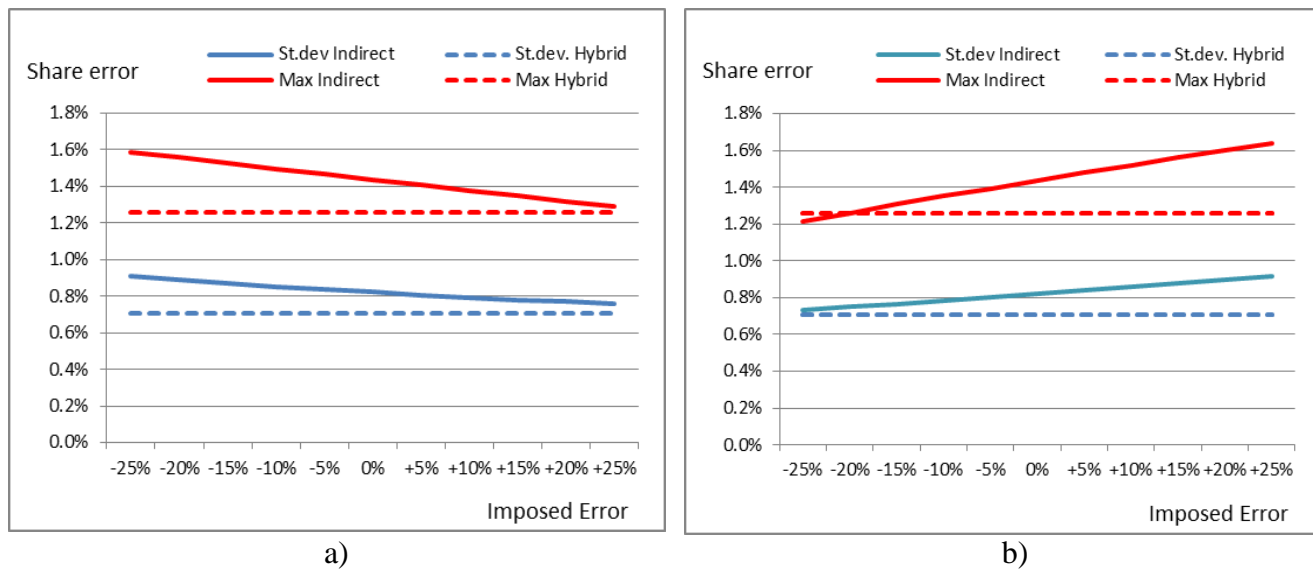

387

388 Figure 8 – Sensitivity analysis of the  $K$  coefficient estimation of radiators: a) error in only one raising  
 389 main (1N), b) error in two raising mains (1N e 3S)

390

391 Authors also evaluated the influence on standard deviation and maximum error of the heat accounting  
392 due to the estimation of the coefficient  $K$  for radiators installed in a single apartment (Figure 9a) and in  
393 two apartments (Figure 9b). This situation occurs, as for example, when a single tenant renovates the  
394 heating system with the replacement of radiators only in few rooms.

395

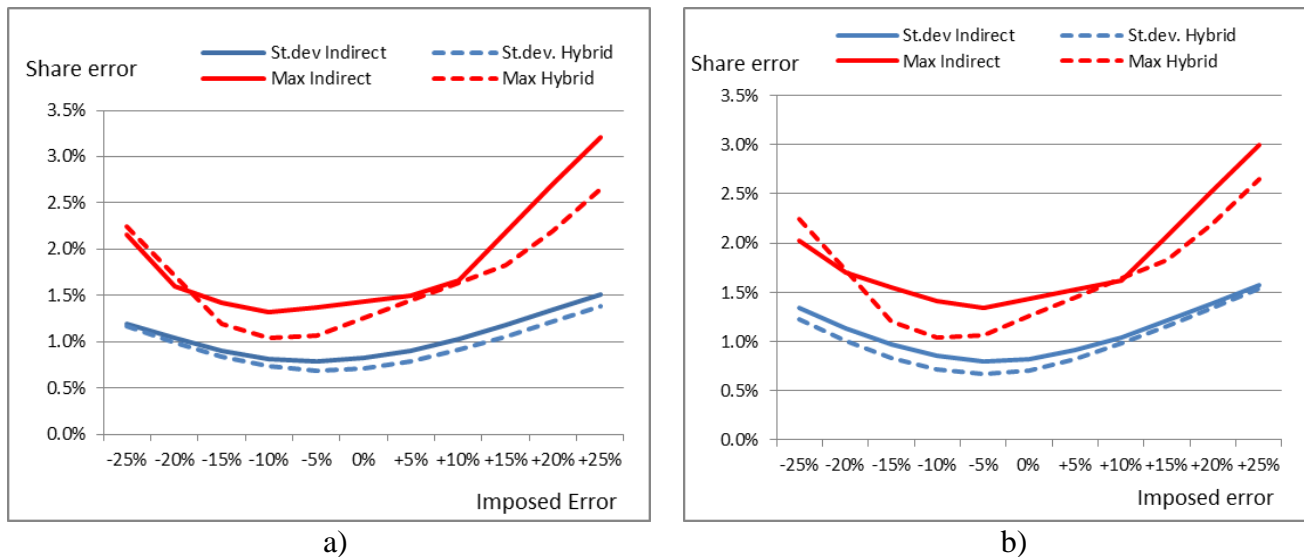

396

397 Figure 9 – Sensitivity analysis of the  $K$  coefficient estimation of radiators: a) error in only one  
398 apartment (Ap\_8), b) error in two apartments (Ap\_7 and Ap\_8)

399

400 From the analysis of the experimental results it can be pointed out that:

401 – standard deviation of Hybrid method error is slightly lower and almost similar to the Indirect  
402 method one,

403 – maximum error of Hybrid method is basically lower in respect to the Indirect method one, except  
404 under specific conditions (e.g. in the investigated case study, when the error of  $K$  is below -20%  
405 both for the case with one and two apartments).

406 The above described results are consistent to the fact that Hybrid method performs a correction on  
407 single raising mains (i.e. in vertical) and when the error of  $K$  is imposed on a column the effect is a  
408 generalized lower share error in respect to the Indirect method. On the other hand, such correction is  
409 not always effective in some apartments (i.e. in horizontal), in which share error could be randomly  
410 lower or higher. In fact, when the errors of  $K$  are introduced in single apartments (e.g. due to the  
411 replacement of radiators whose heat outputs are not accurately known), larger systematic share errors

412 of Hybrid method in respect to the Indirect one may occur in a completely random way, according to  
413 the number of single accounting devices involved in the radiator replacement in the apartment.  
414 In conclusion, the sensitivity analysis shows the hybrid method is basically less affected by the error on  
415 the estimation of coefficient  $K$ , except in few random conditions in which the imposed error is  
416 concentrated in single apartments.

417

418

## 419 6. Conclusions

420

421 In this paper the authors proposed a novel “hybrid” method aimed at improving accuracy of heat  
422 accounting in historical buildings supplied by centralized heating systems, by merging the advantages  
423 of indirect method with the higher accuracy typical of direct methods. The on-field accuracy of the  
424 developed method has been experimentally evaluated in comparison with the traditional direct and  
425 indirect ones at INRIM, the primary metrology institute in Italy, in a specially designed experimental  
426 mockup, simulating a virtual four-storey/eight-apartments building.

427 The experimental analysis shows that the proposed hybrid method always performs better than the  
428 indirect one. The advantage can be particularly relevant for buildings presenting standard apartment  
429 configurations and for occasionally occupied buildings.

430 In particular, the experimental results demonstrated that:

- 431 – in the whole investigated period and both for full and occasional occupancy conditions the  
432 standard deviation of accounting errors is equal to 1.22% and 0.89% for the indirect and hybrid  
433 method respectively;
- 434 – when occasional occupation conditions occur, the lowering of both maximum error (reduction  
435 of approximately 41.3%) and  $wRMSE$  (average reduction of about 19.9%) has been found for  
436 the hybrid method with respect to the indirect one;
- 437 – the hybrid method is not affected in any way by the error on the evaluation of the  $K$  coefficient  
438 for radiators installed on the same vertical raising main (e.g. error in the evaluation of the  
439 nominal heat output of radiators of the same type), whereas the indirect method shows a linear  
440 trend;
- 441 – the hybrid method tends to be less affected by the systematic error on the  $K$  coefficient for  
442 radiators installed in the same apartment (e.g. case of the renovation of the heating system) with  
443 respect to the indirect one.

444 The proposed method, therefore, despite the higher cost due to the installation of direct thermal energy  
 445 meters on single vertical raising mains, could be particularly effective in old tower buildings where the  
 446 accurate estimation of the  $K$  coefficients of installed radiators is particularly difficult. It is therefore the  
 447 intention of the authors to perform an experimental campaign aimed at assessing on the field the  
 448 accuracy of the proposed hybrid method in a real building case study.

449

450

## 451 Acknowledgements

452

453 This work has been developed under the projects “Ricerca di Sistema Elettrico PAR 2016” funded by  
 454 ENEA (grant number I12F16000180001) “PRIN Riquilificazione del parco edilizio esistente in ottica  
 455 NZEB” funded by MIUR (grant number 2015S7E247\_002).

456

457

## 458 Acronyms and Symbols

459

EED	Energy Efficiency Directive
HCA	Heat cost allocator
HM	Heat Meter
MID	Measuring Instrument Directive
PLC	Programmable logic computer
St.dev	Standard deviation
$AU_b$	Allocation units of the whole building for the indirect method, dimensionless
$AU'_b$	Allocation units of the whole building for the hybrid method, dimensionless
$AU_{i,j}$	Allocation unit of each $j$ -th radiator in the $i$ -th apartment (indirect), dimensionless
$AU'_{i,j}$	Allocation unit of each $j$ -th radiator in the $i$ -th apartment (hybrid), dimensionless
$AU_i$	Allocation unit of the $i$ -th apartment of the building for the indirect method, dimensionless
$AU'_i$	Allocation unit of the $i$ -th apartment of the building for the hybrid method, dimensionless
$AU_{k,j}$	Allocation unit of the single raising main, dimensionless.
$AU_k$	Allocation units of the single raising main, dimensionless
$E\%_{max}$	maximum relative display deviation, dimensionless
$E_i$	errors of the shares for hybrid and indirect methods
$K_C$	rating factor for thermal contact between HCA and radiator
$K_Q$	rating factor for the nominal thermal power of the radiator
$Q_b$	Total thermal energy consumed in the building, kWh
$Q_i$	Thermal energy consumed by the single $i$ -th apartment, kWh
$Q_{k,j}$	energy consumed in the single raising main, kWh
$Q_k$	Thermal energy supplied along each $k$ -th vertical raising main, kWh

$Q_k$	thermal energy supplied along each vertical $k$ -th, kWh
$R_{AU}$	heat cost allocator display resolution, dimensionless
$S_{HM}$	Individual share of each $i$ -th apartment (reference direct), dimensionless
$S_i$	Individual share of each $i$ -th apartment (indirect), dimensionless
$S'_i$	Individual share of each $i$ -th apartment (hybrid), dimensionless
$\dot{V}$	radiator volumetric flow rate, $m^3 s^{-1}$
$c_p$	specific heat capacity of the heat conveying fluid, $kJ kg^{-1} K^{-1}$
$n_i$	Number of apartments in the building, dimensionless
$n_j^i$	Number of radiators in each $i$ -th apartment, dimensionless
$n_j^k$	Number of $j$ -th radiators installed on the same $k$ -th vertical raising main, dimensionless
$n_k$	Number of vertical raising mains in the distribution plant, dimensionless
$H$	Radiator height, m
$K$	resulting rating factor of the heat cost allocator
$L$	Radiator length, m
$U(E_i)$	expanded uncertainty of errors, dimensionless
$W$	Radiator width, m
$t$	time period, s.
$u(K_Q)$	standard uncertainty of rating factor $K_Q$ , kWh
$u(Q_i)$	standard uncertainty of individual apartments heat consumption, dimensionless
$u(S_{HM,i})$	standard uncertainty of the share ref. thermal energy measurements, dimensionless
$u(Q)$	standard uncertainty of thermal energy measurement, kWh
$wRMSE$	weighted Root-Mean-Square-Error, dimensionless
$\Delta T_{io}$	temperature difference between the inlet and outlet flow section of the radiator, $^{\circ}C$
$\Delta T_r$	Temperature difference between heating fluid and indoor ambient temperature, $^{\circ}C$
$\rho$	density of the heat conveying fluid, $kg m^{-3}$

460

461

462

463 **References**

464

465 [1] Energy Efficiency Directive (EED) European Commission. Directive 2012/27/EU of the  
466 European Parliament and of the Council of 25 October 2012 on energy efficiency, amending  
467 Directives 2009/125/EC and 2010/30/EU and repealing Directives 2004/8/EC and 2006/32/EC,  
468 2012.

469 [2] Directive (EU) 2018/844 of the European Parliament and of the Council of 30 May 2018  
470 amending Directive 2010/31/EU on the energy performance of buildings and Directive  
471 2012/27/EU on energy efficiency, 2018

472 [3] European Committee for Standardization (CEN). EN 1434-1:2016 Heat meters - Part 1: General  
473 requirements. 2015

474 [4] European committee for Standardization (CEN). UNI EN 834:2013. Heat cost allocators for the  
475 determination of the consumption of room heating radiators - Appliances with electrical energy  
476 supply. 2013.

- 477 [5] Italian National Unification. UNI 11388:2015. Heat costs allocation system based on insertion  
478 time compensated by average temperature of the fluid (in Italian language only). (2015).
- 479 [6] Italian National Unification. UNI 9019:2013 Heat costs allocation based on indirect accounting  
480 for the useful thermal energy calculation by insertion time counter compensated with the degree-  
481 days of the building unit. (2013)
- 482 [7] MID directive European Commission. Directive 2014/32/EU of the European parliament and of  
483 the council of 26 February 2014 on the harmonisation of the laws of the Member States relating  
484 to the making available on the market of measuring instruments (recast), 2014
- 485 [8] G.Ficco, A.Frattolillo, A.Malengo, G.Puglisi, F.Saba, F.Zuena. Field verification of thermal  
486 energy meters through ultrasonic clamp-on master meters. *Measurement* (2020), 151,107152
- 487 [9] L. Celenza, M. Dell'Isola, G. Ficco, B.I. Palella, G. Riccio, Heat accounting in historical  
488 buildings, *Energy Build.* 95 (2015) 47–56
- 489 [10] L. Canale, M. Dell'Isola, G. Ficco, B. Di Pietra, A. Frattolillo. Estimating the impact of heat  
490 accounting on Italian residential energy consumption in different scenarios. *Energy and*  
491 *Buildings.* 168 (2018) 385-98.
- 492 [11] M. Dell'Isola, G. Ficco, L. Canale, A. Frattolillo, I. Bertini. A new heat cost allocation method  
493 for social housing. *Energy and Buildings.* 172 (2018) 67-77.
- 494 [12] G. Ficco, L. Celenza, M. Dell'Isola, P. Vigo. Experimental comparison of residential heat  
495 accounting systems at critical conditions. *Energy and Buildings.* 130 (2016) 477-487
- 496 [13] M. Dell'Isola, G. Ficco, F. Arpino, G. Cortellessa, L. Canale. A novel model for the evaluation of  
497 heat accounting systems reliability in residential buildings. *Energy and Buildings* 150 (2017)  
498 281-93
- 499 [14] F. Saba, V. Fernicola, M.C. Masoero, S. Abramo. Experimental Analysis of a Heat Cost  
500 Allocation Method for Apartment Buildings. *Buildings.* 7 (2017).
- 501 [15] C.Marinari, F.Saba, F.Grisotto, M.Orio, M.Masoero. The INRiM thermo-hydraulic mock-up for  
502 thermal energy measurement devices: Design, construction and metrological characterization.  
503 *Energy Procedia* (2015), 78, pp. 2304-2309
- 504 [16] European Committee for Standardization (CEN). EN 442-1: Radiators and convectors - Part 1:  
505 Technical specification and requirements. 2014.
- 506 [17] European Committee for Standardization (CEN). EN 442-2 Radiators and Convectors—Part 2:  
507 Test Methods and Rating. 2014
- 508 [18] G.Betta, M.Dell'Isola. Optimum choice of measurement points for sensor calibration.  
509 *Measurement* (1996), 17(2), pp. 115-125
- 510 [19] JCGM 100:2008 GUM 1995 with minor corrections. Evaluation of measurement data. Guide to  
511 the expression of uncertainty in measurement
- 512 [20] IAPWS R7-97(2012) Revised Release on the IAPWS Industrial Formulation 1997 for the  
513 Thermodynamic Properties of Water and Steam, August 2007
- 514 [21] F.Arpino, G.Cortellessa, M.Dell'Isola, G.Ficco, R.Marchesi, C.Tarini. Influence of installation  
515 conditions on heating bodies thermal output: preliminary experimental results. *Enrgy Proced.* 101  
516 (2016) 74-80.

[Click here to view linked References](#)

# A novel measurement method for accurate heat accounting in historical buildings

M. Dell'Isola<sup>1</sup>, G. Ficco<sup>1</sup>, B. Di Pietra<sup>2</sup>, F. Saba<sup>3</sup>, M.C. Masoero<sup>4</sup>

<sup>1</sup> DICeM, Department of Civil and Mechanical Engineering, University of Cassino and Southern Lazio, Via Di Biasio 43, 03043 Cassino, Italy. ph. +39 (0)7762993666, fax +39 (0)7762994002, email: dellisola@unicas.it

<sup>2</sup> ENEA - Dipartimento Unità per l'Efficienza Energetica (DUEE) - Via Anguillarese, km 1.150 - 00123 Roma, Italy

<sup>3</sup> INRIM Istituto Nazionale di Ricerca Metrologica, Strada delle Cacce 91, Torino, Italy

<sup>4</sup> DENERG -Dipartimento Energia, Politecnico di Torino, Corso Duca degli Abruzzi, 24 - 10129 Torino. Italy

**Abstract** – Nowadays, two different heat accounting methods are available: the direct method, based on heat meters, and the indirect one, based on heat cost allocators. Unfortunately, in existing buildings, due to the plant configuration, heat meters are often technically unfeasible or not cost efficient, whereas heat cost allocators can be easily installed in almost all conditions. At the same time, the indirect method relies on a high number of interconnected devices with installation and operative conditions often variable within the same building and influencing the on-field metrological performances. In this paper, the authors propose a novel “hybrid” method for accurate heat accounting combining the advantages of indirect method with the higher accuracy typical of direct methods. The proposed method has been experimented at INRIM, the primary metrology institute in Italy, assessing the on-field performance in a virtual eight-apartments building. The experimental results show that the proposed method always presents improved accuracy.

**Keywords:** heat accounting, heat meter, heat cost allocator, accuracy, historical buildings.

## 1. Introduction

The Energy Efficiency Directive (EED) 2012/27/EU [1] and its subsequent recast 2018/844/EU [2] identified individual heat accounting as an essential tool for improving energy efficiency in buildings.

32 To this aim, EED has set the obligation to install heat accounting systems for individual measurement  
33 of energy consumption of space heating in condominium buildings supplied by district heating or by a  
34 common centralized system, when technically feasible and economically convenient. Heat accounting  
35 methods can be classified into two main categories: i) direct methods, which provide through heat  
36 meters (HM) [3] an accurate measurement of the thermal energy consumed by each apartment within a  
37 building through an energy balance on the flow and return pipes of the heating/cooling circuit; ii)  
38 indirect methods, which provide estimates proportional to the heat exchanged between single heating  
39 elements and ambient of each apartment through dimensionless allocation units (*AU*). To this last  
40 category belong the heat cost allocators (HCA) [4] and the insertion time counters compensated with  
41 the heating fluid temperature [5] or with the degree days [6]. HMs are the most accurate devices  
42 currently available on the market for thermal energy measurement presenting also the peculiarity of  
43 being regulated by legal metrology MID directive [7] thus providing specific guarantees and consumer  
44 protection in terms of type approval, production, installation, initial and periodic verifications [8]. HMs  
45 are among the most used in new buildings, generally provided with central heating system and  
46 horizontal distribution configuration with manifolds for single apartments [9]. HCAs, on the other  
47 hand, are the most popular and widely used indirect accounting systems in northern and central  
48 European countries (such as Germany, Austria, Denmark). Besides, there is a huge theoretical potential  
49 for installation in existing buildings also in other European countries (estimated at around 20 million)  
50 such as Spain, France and Italy. In particular, in Italy the estimated multi-family buildings stock where  
51 individual measurement systems are not yet installed, is approximately 4.5 million [10].

52 The EED directive allows indirect heat accounting methods to be used when the direct one is not  
53 technically feasible and/or economically efficient. As a matter of fact, in many historical buildings, due  
54 to architectural constraints and/or to the configuration of the heating system (generally with vertical  
55 raising mains), direct HMs are not always technically feasible or cost efficient. In this case, in fact, it  
56 would be necessary to install one HM for each heating element, with consequent metrological issues  
57 due to low flow-rates and measured temperature differences in addition with unavoidable higher costs.  
58 In Europe, this is a typical situation in almost all historical buildings and in buildings built before the  
59 1980s [9, 11]. Unfortunately, not all heat accounting systems show the same reliability. Besides,  
60 indirect accounting systems show lower measurement accuracy which is extremely dependent on  
61 installation and programming features. A specific methodology for estimating the accuracy and  
62 reliability of indirect heat accounting systems is still lacking in the scientific literature and technical  
63 standards. Moreover, due to the specific architecture of such systems (that is to say a sort of complex

64 distributed system consisting of a large number of similar devices installed on radiators together with  
65 data gathering/storage/processing devices), the accuracy of heat allocation will depend on both the  
66 accuracy of the individual devices and on the different installation and operation characteristics of the  
67 plant. From a field analysis on the different heat metering and accounting methods [12] in fact,  
68 different accuracy levels have been found, ranging from about 4.4% for HMs to 21.6% for insertion  
69 time counters compensated with degree-days. Intermediate accuracy, on the other hand, were estimated  
70 for HCAs (about 9.2%) and for the insertion time counters compensated with the heating fluid  
71 temperature (about 13.4%). In reality, the accuracy of indirect accounting systems in different  
72 operating conditions may vary from about 2.7% (i.e. in a large multi-family building in optimal  
73 conditions) to about 11.7% (i.e. in a two-family building in critical conditions). Furthermore, the  
74 allocation accuracy can be estimated through a model allowing to assess the influence of the  
75 installation conditions with particular reference to the number and type of radiators and of the related  
76 installation, also in relation to the installation issues and use of single apartments. This model can be  
77 adopted both to design appropriate heat accounting systems in new buildings and to evaluate their  
78 reliability in existing ones. [13].

79 In this work, aiming at addressing the above mentioned issues of accounting methods in existing  
80 buildings with a centralized heating system, especially for large buildings and occasionally lived, the  
81 authors propose a novel accounting method, namely the "hybrid heat accounting" method. The  
82 proposed method relies on indirect systems on single radiators and on direct heat meters on the existing  
83 raising mains of the heating plant, merging the advantages of direct and indirect allocation methods. In  
84 particular, in respect to the actual available heat accounting methods such as proportional methods  
85 based on floor area or installed heat power or indirect HCAs, it allows knowing the consumption of  
86 each room in the apartment typical of indirect methods and it is expected to show an increasing  
87 accuracy and reliability of the share typical of direct methods. The metrological performance of the  
88 proposed method was analysed at the experimental mockup of INRIM, the National Metrological  
89 Research Institute of Turin, specifically configured to simulate field operation of an eight apartments  
90 building. Through a specific design of the experiments, it was possible to assess the influence of some  
91 operating parameters such as: i) the usage mode (occasional or continuous) by excluding some  
92 apartments; ii) the different consumption due to changes in the external climatic conditions through the  
93 variation of the heating fluid flow and temperatures.

94

95

96 **2. Theory and Methods**

97

98 The direct heat accounting method allows accurate measurement of the energy supplied to each  
99 apartment, at the same time showing generally high commissioning costs and above all an intrinsic  
100 limitation of use in buildings with vertical distribution. On the other hand, the heat accounting method  
101 does not directly measure the energy consumed but estimates dimensionless allocation units  
102 proportional to it, presenting a lower accuracy together with simpler installation and basically lower  
103 costs. Furthermore, indirect methods allow to discriminate the consumption of each emission element  
104 and therefore of each room within the apartment. Figure 1 shows the two typical operational schemes  
105 of distributed heating plants in existing condominium buildings supplied by a common centralized  
106 system. In ring distribution plants direct heat accounting with HMs is in principle technically feasible,  
107 whereas in vertical mains distribution ones only indirect accounting systems combine technical  
108 feasibility and economic convenience.

109

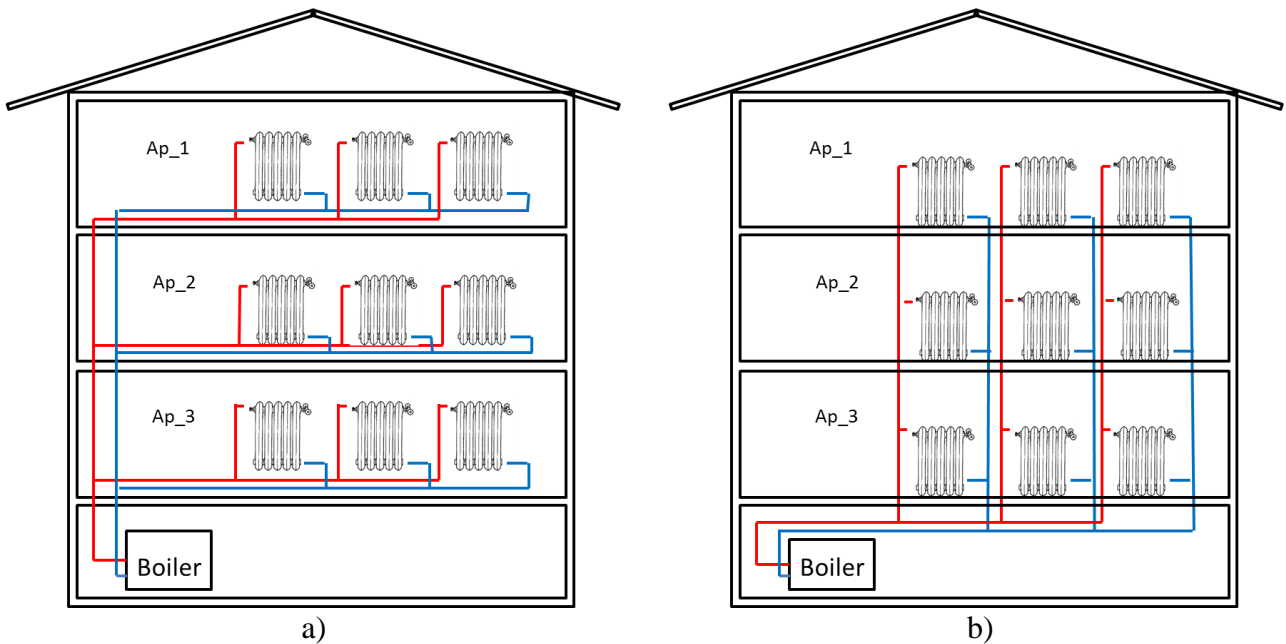

110 Figure 1 – Heating plant configurations of distributed heating plants: a) Ring distribution, b) Vertical  
111 mains distribution  
112

113

114 2.1 Direct and indirect heat accounting methods

115

116 When a direct heat accounting method is applied, the "individual" share of single apartments,  $S_i$  (%), is  
 117 estimated by calculating the ratio between the energy consumed by the single apartment (measured  
 118 through HMs used as sub-meters),  $Q_i$  (kWh), and the total energy consumed in the building,  $Q_b$  (kWh),  
 119 and measured by a supply thermal energy meter (e.g. through a HM in the heat exchange substation in  
 120 the case of supply from district heating, or the energy measured by a gas meter if the boiler is supplied  
 121 by natural gas network), as per equation (1).

$$S_i = \frac{Q_i}{Q_b} \quad (1)$$

122 On the other hand, for indirect heat accounting methods, the allocation unit of the  $i$ -th apartment of the  
 123 building ( $AU_i$ ), is obtained by summing the allocation unit of each  $j$ -th radiator in the apartment ( $AU_{i,j}$ ),  
 124 as per eq.(2). Then, the share  $S_i$  of each  $i$ -th apartment (i.e. the so-called "voluntary" heat  
 125 consumptions) is given by the following equation (3).

$$AU_i = \sum_{j=1}^{n_j^i} AU_{i,j} \quad (2)$$

$$S_i = \frac{AU_i}{AU_b} = \frac{\sum_{j=1}^{n_j^i} AU_{i,j}}{\sum_{i=1}^{n_i} \sum_{j=1}^{n_j^i} AU_{i,j}} \quad (3)$$

126 where  $n_j^i$  is the number of radiators (which is usually equal to the number of columns in the heating  
 127 plant) in each  $i$ -th apartment and  $n_i$  is the number of apartments in the building, respectively.

128

## 129 2.2 The novel "hybrid heat allocation" method

130

131 The novel hybrid allocation method has been developed at the LAMI, the industrial measurement  
 132 laboratory of the University of Cassino and Southern Lazio, and consists of indirect heat accounting  
 133 devices (e.g. HCAs) installed on each radiator and direct HMs installed at the base of each raising main  
 134 of the heating distribution plant in addition to the supply HM, as shown in Figure 2.

135

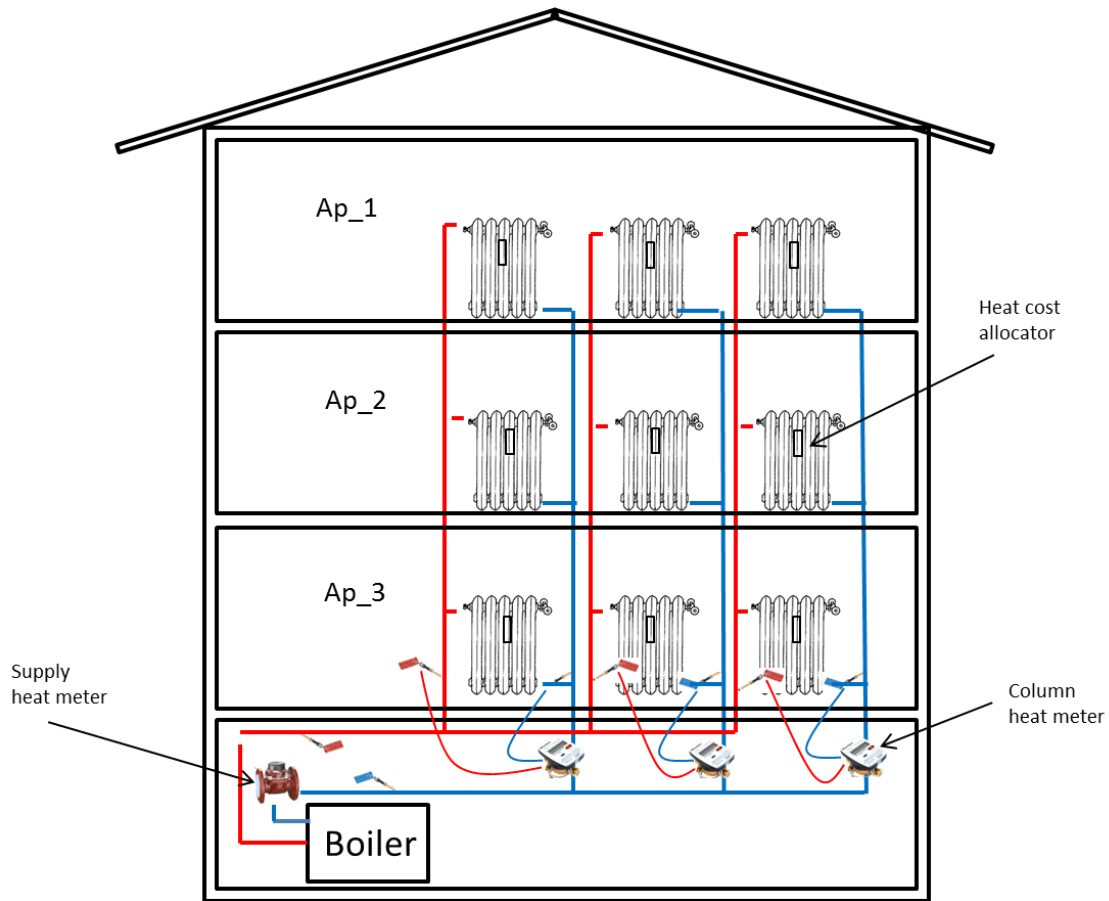

Figure 2 – Hybrid heat allocation method scheme

136

137

138

139

140 The possibility of improving the metrological performance of indirect accounting devices in buildings  
 141 supplied by centralized heating plant with vertical raising mains was first proposed by Celenza et al.  
 142 [9]. In this case, heat allocation is carried out selectively on each column and not on the entire building,  
 143 also allowing in this way:

- 144 – to verify the thermal energy produced by the boiler and, therefore, to monitor its efficiency and  
 145 promptly schedule eventual maintenance interventions;
- 146 – to evaluate the individual share of heat consumption, considering groups of radiators with  
 147 similar installation conditions and nominal heat output, like the radiators on each vertical  
 148 raising main; indeed, the apartment typology and the rooms distribution is typically repetitive  
 149 for the overlapping floors, thus, higher accuracy of the accounting is expected as a positive  
 150 effect of the compensation of the similar systematic errors affecting the indirect heat accounting  
 151 devices;

- 152 – to monitor the energy consumption of single rooms, maintaining at the same time the energy  
 153 measurement on each column;
- 154 – to show the economy and simplicity of installation of indirect devices with a slight additional  
 155 cost depending on the number of vertical raising mains. For example, in a ten-story building  
 156 with 20 apartments and 100 heating elements with a heating distribution system with 5 columns  
 157 (i.e. needing the installation of 5 HMs additional to the indirect system) the increase of fixed  
 158 cost for commissioning would be about 15-20%.

159 The direct measurement on the vertical raising mains returns the values of the thermal energy  $Q_k$  (kWh)  
 160 supplied along each vertical  $k$ -th and therefore the total one of the building as per eq.(5). Allocation  
 161 unit  $AU'_{i,j}$  of each radiator in the hybrid method is then given by eq. (6).

$$Q_b = \sum_{k=1}^{n_k} Q_k \quad (5)$$

$$AU'_{i,j} = AU_{i,j} \frac{AU_b}{AU_k} \frac{Q_k}{Q_b} = AU_{i,j} \frac{\sum_{i=1}^{n_i} \sum_{j=1}^{n_j^i} AU_{i,j}}{\sum_{j=1}^{n_j^k} AU_{i,j}} \frac{Q_k}{Q_b} \quad (6)$$

162 where  $n_k$  is the number of the vertical raising mains in the distribution plant,  $n_j^i$  is the number of  
 163 radiators in each  $i$ -th apartment and  $n_j^k$  is the number of radiators installed on each raising main.

164 For the sake of simplicity, it can be argued that a correction factor is introduced which depends on both  
 165 the ratio between the energy consumed in the single raising main ( $Q_{k,j}$ ) and the total in the building  
 166 ( $Q_b$ ) and between the total  $AU_b$  in the building and the  $AU_{k,j}$  in the single raising main.

167 Therefore, the share  $S'_i$ , of each  $i$ -th apartment (i.e. the so-called "voluntary" heat consumptions) is  
 168 given by the following equation:

$$S'_i = \frac{AU'_i}{AU'_b} = \frac{\sum_{j=1}^{n_j^i} AU'_{i,j}}{\sum_{i=1}^{n_i} \sum_{j=1}^{n_j^i} AU'_{i,j}} = \frac{\sum_{j=1}^{n_j^i} \left( \frac{AU_{i,j}}{\sum_{j=1}^{n_j^k} AU_{i,j}} \frac{Q_k}{Q_b} \right)}{\sum_{i=1}^{n_i} \sum_{j=1}^{n_j^i} \left( \frac{AU_{i,j}}{\sum_{j=1}^{n_j^k} AU_{i,j}} \frac{Q_k}{Q_b} \right)} \quad (7)$$

169

170

171 2.3 Design of experiments

172

173 The authors designed an experimental campaign at the Energy Measurement Laboratory of INRIM, the  
174 National Metrology Institute of Turin, aimed at evaluating the performance of the novel hybrid  
175 accounting method. The test facility (Figure 3) consists of a full-scale central heating system with 40  
176 radiators characterized by different shapes, hydraulic connections, dimensions and materials, installed  
177 on four levels and connected through a hydraulic circuit which can be automatically set in order to  
178 simulate alternatively raising mains or single pipe horizontal distribution plant configuration.

179



180

181

182 Figure 3 - Heat accounting experimental mockup at INRIM

183

184 The test facility allows testing both conventional and innovative heat accounting systems and methods  
185 in experimental conditions similar to the operational ones [14, 15]. The experimental mockup has been  
186 configured with vertical raising main distribution, which is the typical application case of the indirect  
187 heat accounting through HCAs in historical buildings. Figure 4 shows the layout of the experimental  
188 mockup with the identification of the individual heating elements and vertical mains.

189

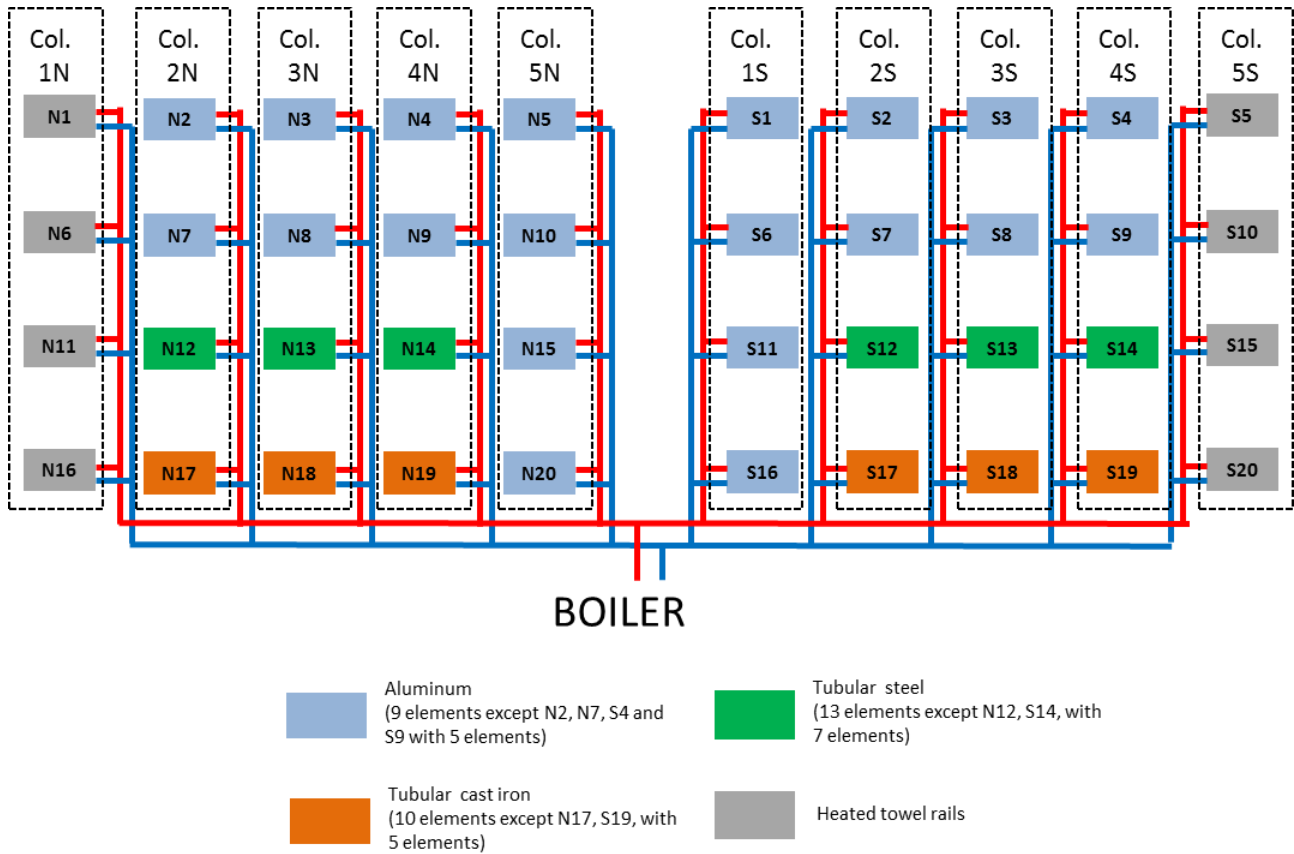

190

191

192 Figure 4 - INRIM mockup for heat accounting measurements with vertical raising main configuration

193

194 In Table 1 a summary of the technical characteristics of the radiators installed in the experimental  
 195 mockup is reported.

196

197

Table 1– Technical characteristics of the radiators of the experimental mockup

<i>Radiator type and id.</i>		<i>Number of radiator elements</i>	<i>Radiator Dimensions (H, L, W), mm</i>	<i>Nominal Heat output EN 442 [16, 17] <math>\Delta T_r = 50^\circ\text{C}, W</math></i>	<i>Radiator exponent (EN 442)</i>
Aluminum	N3, N4, N5, N8, N9, N10, N15, N20, S1, S2, S3, S6, S7, S8, S11, S16	9	720, 870, 80	1.36	1716
	N2, N7, S9, S4	5	400, 870, 80		973
Cast iron	N18, N19, S17, S18	10	600, 880, 140	1.37	2044
	S19, N17	5	300, 880, 140		1060
Steel	N13, N14, S12, S13	13	590, 900, 150	1.28	1908
	S14, N12	7	320, 900, 150		1073
Heated towel rail	N1, N6, N11, N16, S5, S10, S15, S20	-	535, 713, 30	1.25	496

198

199 To compare the performance of the novel hybrid method against a conventional indirect heat  
200 accounting method, 40 two-sensors electronic HCAs (EN 834 approved) have been installed on the  
201 mockup radiators and programmed according to the manufacturer's instructions. Reference data are  
202 provided by combined HMs made up of an electromagnetic flow meter, a pair of Pt100 resistance  
203 thermometers and a thermal energy calculation unit directly implemented on the central control PC,  
204 which receives the converted measurement signals from a Programmable Logic Controller (PLC).

205 The sub-assemblies of HMs are periodically calibrated at the INRIM laboratories, guaranteeing the  
206 necessary metrological traceability to the national standards. In particular:

- 207 – electromagnetic flow meters are calibrated by comparison with a reference electromagnetic  
208 flow meter (which is in turn calibrated against the national standard of liquid flow rate), on at  
209 least five flow rate values, automatically configuring the hydraulic circuit so that the flow  
210 meters of single radiators are in series with the reference meter;
- 211 – temperature sensors are calibrated by comparison with a reference Pt100 resistance  
212 thermometer in a thermostatic bath.

213 The entire system is monitored and controlled by means of a SCADA-HMI software, through which it  
214 is possible to vary the working points of the centralized generator, the circulation pump and the  
215 opening and closing states of the valves of each heating body, intervening both manually and  
216 automatically according to a predetermined program. Thus, it is possible to adjust the flow temperature  
217 and the flow rate of the heat transfer fluid in each radiator. Furthermore, through the automatic system,  
218 the output signals of the reference direct heat meters (power, thermal energy, flow rate, inlet and outlet  
219 temperatures) can be logged with a sampling interval of at least 15 s.

220 With the aim to reproduce as far as possible the typical installation and operational conditions on the  
221 field, the experimental mockup has been configured as a virtual four-storeys / eight-apartments  
222 building (Figure 5). Each virtual floor consists of two apartments: a two-room apartment with four  
223 radiators (apartments 1, 3, 5 and 7) and a four-room apartment with six radiators (apartments 2, 4, 6  
224 and 8). Therefore, the centralized heating plant presents ten vertical raising mains. The four vertical  
225 raising mains of the two-room apartments are characterized by identical radiators with the same heat  
226 output, whereas the six vertical raising mains of the four-room apartments consist of radiators of  
227 different type, but similar nominal heat output.

228

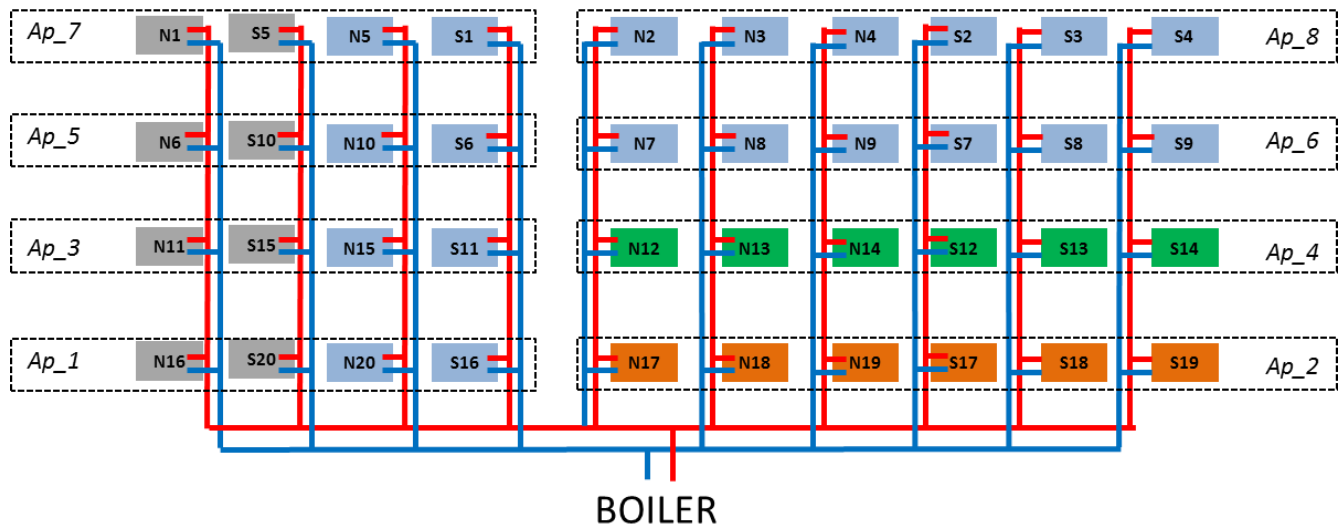

229  
230

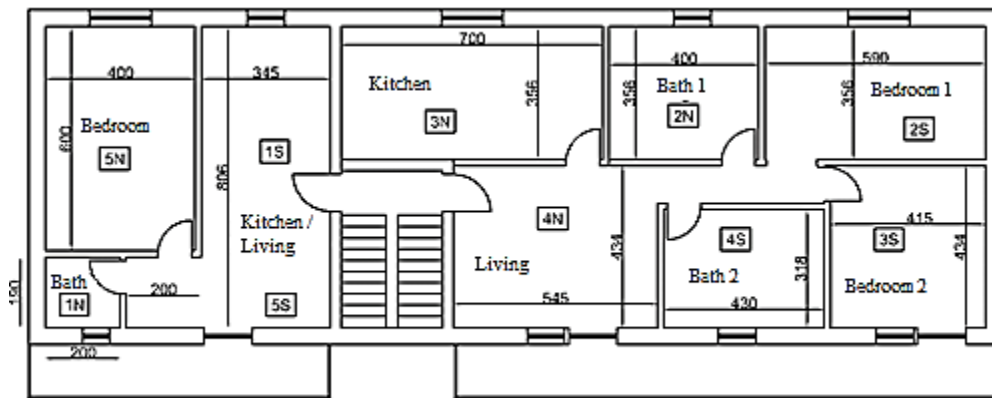

231  
232  
233

Figure 5 – Experimental set-up and corresponding virtual building

234 The authors also performed the calculation of the thermal energy need and the related radiators nominal  
 235 heat output of the virtual building, considering the requirements of the climatic zone “E” where the  
 236 INRIM experimental mockup is located. For such a climatic zone, the heating period is between  
 237 October 15<sup>th</sup> and April 15<sup>th</sup> for a maximum daily operation of 14 hours. The indoor temperature of the  
 238 heated rooms and the minimum outdoor temperature in the winter period have been conventionally set  
 239 at 20°C and -8°C, respectively. Based on such design data and on the nominal heat output of each  
 240 radiator of the mockup, the virtual test rooms to which each radiator is associated have been identified.  
 241 Consequently, three different climatic periods of the heating season from October 15<sup>th</sup> to April 15<sup>th</sup>  
 242 were identified for which the average temperatures of Turin and the corresponding heat requirements

243 for each room have been calculated, as well as the heat output and heating fluid flow-rates, assuming a  
244 temperature difference between supply and return of about 10 °C (see table 3).

245 In order to evaluate the performance of the novel hybrid accounting method in test conditions close to  
246 the real dynamic operating conditions, the experiments were designed considering [18]:

- 247 – three different combinations of total flow rate and supply temperature of the heating plant,  
248 simulating the real operation of the system in three periods of the heating season (namely “warm”,  
249 “cold” and “very cold”) characterized by different average outdoor temperatures (13 °C, 6.5 °C and  
250 0 °C, respectively);
- 251 – different time programmed heating load profiles, consisting of an initial phase of variable duration  
252 (from 30 min to 90 min) in which the heater is set at its peak load (time duration and peak heating  
253 power depend on the simulated period of the heating season), followed by a steady mode heating  
254 phase of 4 hours and a final cooling phase of about 2 hours for radiators surface cooling down to the  
255 indoor ambient temperature (each heating profile has been repeated four times consecutively);
- 256 – different combinations of open and closed radiators, simulating different occupational modes of the  
257 building and usage of the heating plant (tests have been carried out both with all radiators open and  
258 with the radiators of some apartments alternatively closed).

259 The test conditions for the evaluation of the performance of the novel hybrid accounting method are  
260 summarised in table 2.

261

262

Table 2 – Test conditions

<i>Period</i>	<i>Start</i>	<i>End</i>	<i>Av. outdoor temp.</i>	<i>Transient</i>	<i>Occupancy conditions</i>
Warm	October 15 <sup>th</sup>	November 15 <sup>th</sup>	13 °C	30 min	All apartments occupied
	March 15 <sup>th</sup>	April 15 <sup>th</sup>	13 °C		Ap_7 and Ap_8 not occupied
Cold	November 15 <sup>th</sup>	December 15 <sup>th</sup>	6,5 °C	60 min	All apartments occupied
	February 15 <sup>th</sup>	March 15 <sup>th</sup>	6,5 °C		Ap_3 and Ap_4 not occupied
Very cold	December 15 <sup>th</sup>	January 15 <sup>th</sup>	0 °C	90 min	All apartments used
	January 15 <sup>th</sup>	February 15 <sup>th</sup>	0 °C		Ap_3, 4, 7 and 8 not occupied

263

264

265 **4. Uncertainty estimation of heat accounting hybrid method**

266

267 **4.1 Uncertainty estimation of reference thermal energy measurement and of the allocation units**

268

269 The uncertainty estimation of the reference thermal energy measurements is carried out considering the  
270 measurement model given by the energy conservation law [19]:

$$Q = \int \rho \dot{V} c_p \Delta T_{io} dt \quad (8)$$

271 where  $\rho$  and  $c_p$  are, respectively, the density and the specific heat capacity of the heat conveying fluid  
272 (water),  $\Delta T_{io}$  is the temperature difference between the inlet and outlet flow section of the radiator,  $\dot{V}$  is  
273 the radiator volumetric flow rate and  $t$  is the time. Thus, applying uncertainty the propagation law and  
274 considering the measurement quantities are not correlated, standard uncertainty of the reference  
275 thermal energy measurement can be evaluated approximately as:

$$u(Q) \cong Q \sqrt{\left[\frac{u(\dot{V})}{\dot{V}}\right]^2 + \left[\frac{u(\Delta T)}{\Delta T}\right]^2 + \left[\frac{u(\rho)}{\rho}\right]^2 + \left[\frac{u(c_p)}{c_p}\right]^2} \quad (9)$$

276 The relative uncertainties of density and specific heat capacity of the heat conveying liquid (water)  
277 have been evaluated taking into account the uncertainty contributions of water temperature and  
278 pressure measurements, the uncertainty of the equation of state for the determination of the  
279 thermodynamic properties of water [20] and, finally, the uncertainty of density and specific heat  
280 capacity measurements. The uncertainty contribution of the time integration of radiator thermal power  
281 is assumed to be negligible compared to the other contributions. In table 3 a summary of the single  
282 uncertainty contributions of the HMs sub-assembly modules installed on each radiator has been  
283 reported together with the estimation of the reference thermal energy measurement.

284

285

Table 3 –Uncertainty estimation of the reference thermal energy measurement

<i>HM sub-assembly</i>	<i>Sensor</i>	<i>Standard uncertainty</i>
Flow measurement	Electromagnetic flow meter	0.1% of reading for flow-rates higher than 90 dm <sup>3</sup> h <sup>-1</sup> from 0.1% to 1.0% of reading for flow-rates in the range from 90 dm <sup>3</sup> h <sup>-1</sup> to 20 dm <sup>3</sup> h <sup>-1</sup>
Flow / return temperature difference	Pair of Pt100 resistance thermometers and PLC module for 4-wire resistance measurement	0.04 °C
Calculation of heating fluid thermodynamic properties and time integration of thermal power measurement	Calculation unit implementing approximated formulations of the fluid equation of state	1.0% (with respect to the calculated product between density and specific heat capacity of the fluid)
Standard uncertainty of reference thermal energy measurement		from 0.8 to 2.7 % of reading

287

288 The uncertainty of  $AU$  counted by HCAs has been evaluated considering the following contributions: i)  
 289 the display resolution (i.e.  $R_{AU} = 1$ ), ii) the maximum relative display deviation (i.e.  $E\%_{max} = \pm 5\%$   
 290 in the range of  $15 K \leq \Delta T \leq 40 K$  [4]) and iii) the uncertainty of the estimation of rating factor  $K_Q$   
 291 related to the heat output of radiators (according to EN 442 [16, 17]). The uncertainty of  $AU'$  of hybrid  
 292 method can be considered equal to the indirect method, since the uncertainty contribution of the direct  
 293 thermal energy measurements (heat meters) is negligible with respect to the uncertainty of HCAs.  
 294 Therefore, the standard uncertainty  $u(AU)$  can be evaluated as follows:

$$u(AU) = u(AU') \cong AU \sqrt{2 \left( \frac{R_{AU}}{AU \cdot 2\sqrt{3}} \right)^2 + \left( \frac{E\%_{max}}{\sqrt{3}} \right)^2 + u(K_Q)^2} \quad (10)$$

295

296

#### 297 4.2 Uncertainty estimation of the Share

298

299 The uncertainty of the share obtained through the reference thermal energy measurements at each  
 300 radiator, can be evaluated approximately as:

$$u(S_{HM,i}) \cong S_{HM,i} \sqrt{\left[ \frac{u(Q_i)}{Q_i} \right]^2 + \left[ \frac{u(\sum_1^n Q_j)}{\sum_1^n Q_j} \right]^2 - 2 \frac{cov(Q_i, \sum_1^n Q_j)}{Q_i \sum_1^n Q_j}} \quad (11)$$

301 where the uncertainty of the heat consumption of individual apartments  $u(Q_i)$  is evaluated assuming that  
 302 thermal energy measurements of radiators belonging to the same apartment (i.e. radiators on the same floor)  
 303 are fully correlated. On the other hand, the uncertainty of the overall sum of heat consumptions is  
 304 obtained considering a null correlation between thermal energy measurements of different apartments  
 305 (null correlation between radiators on different floors):

$$u\left(\sum_1^n Q_j\right) \cong \sqrt{\sum_1^n u^2(Q_j)} \quad (12)$$

306 Under the same assumption of uncorrelated thermal energy measurements of single apartments, the  
 307 covariance between a single apartment and the overall heat consumption can be evaluated as:

$$\text{cov}\left(Q_i, \sum_1^n Q_j\right) \cong u^2(Q_i) \quad (13)$$

308 Similarly, the uncertainty of the share obtained through the indirect and the hybrid method, can be  
 309 evaluated as follows:

$$u(S_i) \cong S_i \sqrt{\left[\frac{u(AU_i)}{AU_i}\right]^2 + \left[\frac{u(\sum_1^n AU_j)}{\sum_1^n AU_j}\right]^2 - 2 \frac{\text{cov}(AU_i, \sum_1^n AU_j)}{AU_i \sum_1^n AU_j}} \quad (14)$$

$$u\left(\sum_1^n AU_j\right) \cong \sqrt{\sum_1^n u^2(AU_j)} \quad (15)$$

$$\text{cov}\left(AU_i, \sum_1^n AU_j\right) \cong u^2(AU_i) \quad (16)$$

310

311

312 **4. Results and discussions**

313

314 Table 4 shows the experimental results for the whole investigated period in terms of heat allocation  
 315 units and shares of each apartment. Heating shares are calculated from the HCAs readings by applying  
 316 the conventional indirect method and the novel hybrid method and from the reference direct direct  
 317 method (i.e. through thermal energy meters). The values of indirect and hybrid shares and the  
 318 corresponding errors estimated over the entire test period with respect to the reference direct method  
 319 are also reported.

320 The analysis of results in Table 4 highlighted hybrid method shows a lower maximum absolute error  
 321 (i.e. 1.35% against 2.06%) and a standard deviation of accounting errors equal to 1.22% and 0.89% for  
 322 the indirect and hybrid methods, respectively. In table 4 the measured errors have been discriminated  
 323 at building (i.e. the difference between the calculated share and the one of the reference direct method)  
 324 and at apartment level (i.e. the ratio between this latter and the share of the reference direct method).  
 325 Single errors, although they may appear small if compared to the whole accounting in the building  
 326 (absolute errors), become extremely relevant when compared with the shares charged to each user  
 327 (relative errors). As for example Ap\_1 and Ap\_4 would pay respectively 15.1 % less and 10.6% more  
 328 through the indirect method in respect to the reference direct one, and such difference is smoothed with  
 329 the proposed hybrid method (i.e. 7.9% less and 6.4% more, respectively). The experimental results  
 330 show that the proposed hybrid method leads to a significant improvement in the accuracy of heat  
 331 accounting compared to the indirect one both in terms of standard deviation, weighted mean square  
 332 error (*wRMSE*) and maximum errors.

333

334 Table 4 – Experimental results for the whole investigated period

	<i>Direct method</i>		<i>Indirect method</i>				<i>Hybrid method</i>			
	<i>Q / kWh</i>	<i>S<sub>HM</sub></i>	<i>AU</i>	<i>S</i>	<i>Error (building)</i>	<i>Error (apartment)</i>	<i>AU'</i>	<i>S'</i>	<i>Error (building)</i>	<i>Error (apartment)</i>
Ap_1	429.38	11.83%	299	10.04%	-1.79%	<b>-15.1%</b>	324.54	10.90%	-0.93%	<b>-7.9%</b>
Ap_2	824.92	22.73%	738	24.78%	<b>2.06%</b>	9.0%	710.58	23.86%	1.14%	5.0%
Ap_3	222.06	6.12%	178	5.98%	-0.14%	-2.3%	193.34	6.49%	0.37%	6.1%
Ap_4	502.78	13.85%	456	15.31%	1.46%	10.6%	439.02	14.74%	0.89%	6.4%
Ap_5	352.73	9.72%	273	9.17%	-0.55%	-5.7%	295.95	9.94%	0.22%	2.3%
Ap_6	665.09	18.32%	525	17.63%	-0.69%	-3.8%	505.50	16.97%	<b>-1.35%</b>	-7.4%
Ap_7	212.36	5.85%	171	5.74%	-0.11%	-1.8%	184.20	6.19%	0.34%	5.7%
Ap_8	420.63	11.59%	338	11.35%	-0.24%	-2.1%	324.87	10.91%	-0.68%	-5.9%
Total	3630.0	100.0%	2978	100.0%	0.00%	-	2978.0	100.0%	0.00%	-

335 Note: The maximum absolute errors have been evidenced in bold

336 Table 5 summarizes the results for the indirect and hybrid methods of the tests at different climatic (i.e.  
 337 warm, cold, very cold) and occupancy conditions (i.e. full/not full occupancy) in terms of maximum  
 338 error and of Root-Mean-Square-Error weighted with the estimated uncertainties of the errors  
 339 ( $wRMSE$ ), calculated as per eq.(17):

$$wRMSE = \sqrt{\frac{\sum_i [E_i / U(E_i)]^2}{\sum_i [1 / U(E_i)]^2}} \quad (17)$$

340 where the errors of the shares  $E_i$  for hybrid and indirect methods and the expanded uncertainty of  
 341 errors,  $U(E_i)$ , with a coverage factor  $k=2$  which for a normal distribution corresponds to a probability  
 342 of approximately 95%, have been evaluated as follows.

$$E_i = S_i - S_{HM,i} \quad (18)$$

$$U(E_i) = 2 \sqrt{u^2(S_{HM,i}) + u^2(S_i)} \quad (19)$$

343

344

Table 5 –  $wRMSE$  at different climatic conditions and occupancy

Period and Occupancy conditions		$wRMSE$ , %			Maximum error, %		
		Indirect	Hybrid	Improvement	Indirect	Hybrid	Improvement
Full occupancy	Warm	1,21	0,95	-21,8 %	2.50	1.51	-39.6 %
	Cold	0,93	0,82	-12.0 %	2.04	1.48	-27.3 %
	Very Cold	0,81	0,54	-33,6 %	1.64	0.96	-41.5 %
	Whole full occ. period	0,94	0,72	-23,4 %	1.95	1.23	-36.9 %
Occasional occupancy	Warm,	1,35	0,96	-29,1 %	2.53	1.41	-44.3 %
	Cold	1,30	1,02	-21,5 %	3.69	2.69	-27.0 %
	Very Cold,	1,83	1,31	-28,3 %	2.36	1.53	-35.2 %
	Whole occasional occ. period	0,55	0,44	-19,9 %	2.78	1.63	-41.3 %
Whole period		0,84	0,65	-23,4 %	2.06	1.14	-44.7 %

345

346

347 From data in table 5 it can be highlighted that a reduction of both  $wRMSE$  and maximum error has  
 348 been found when the hybrid method is applied and that in the cold period at not full occupancy error  
 349 peaks of 3.69% for indirect method and 2.69% for hybrid one occur. Therefore, it is possible to state  
 350 that the hybrid method shows in average an accuracy of 1.14% which is much better than the  
 351 conventional indirect method one (equal to 2.06%). It is also interesting to highlight that the hybrid  
 352 method is particularly effective especially when occasional occupation conditions occur. In this case, in  
 353 fact, an improvement in accuracy from 2.78% to 1.63% has been found with respect to the maximum  
 354 error (and from 0.55% to 0.44% in terms of  $wRMSE$ ). In any case, the hybrid method was more  
 355 effective at all the investigated climatic and occupancy conditions.

356 Figure 6 and Figure 7 show a comparison between hybrid and indirect methods in terms of  $wRMSE$   
 357 and of maximum error, respectively. It can be highlighted that hybrid method shows better accuracy at  
 358 any climatic condition and both for full or not-full occupancy.  
 359

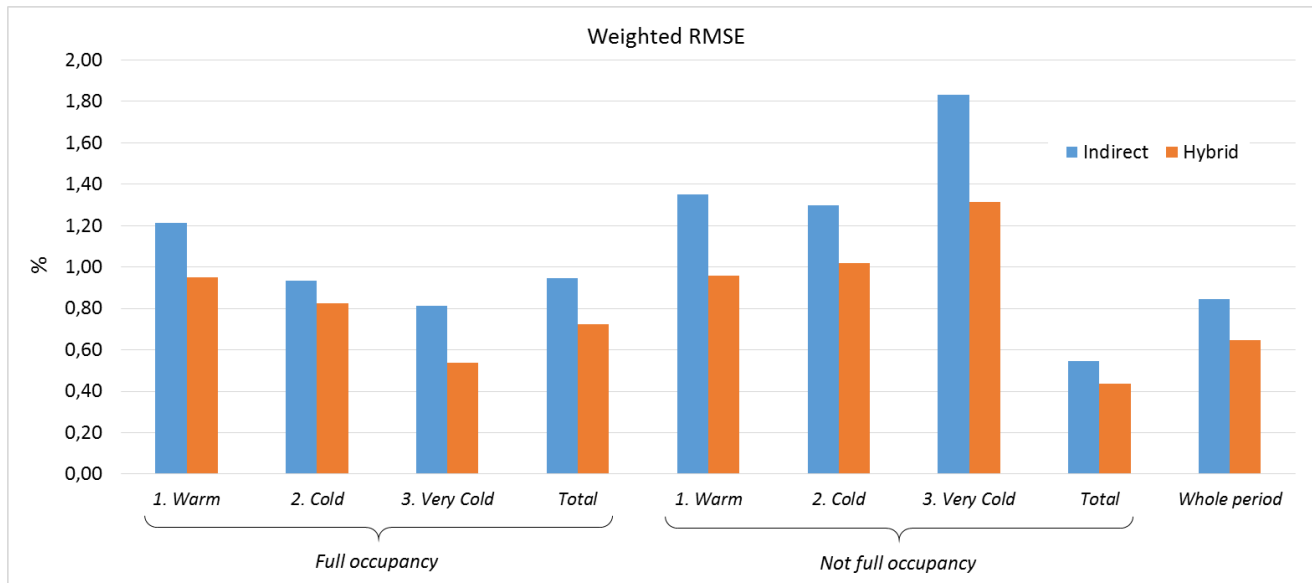

360  
 361 Figure 6 –  $wRMSE$  of indirect and hybrid methods

362

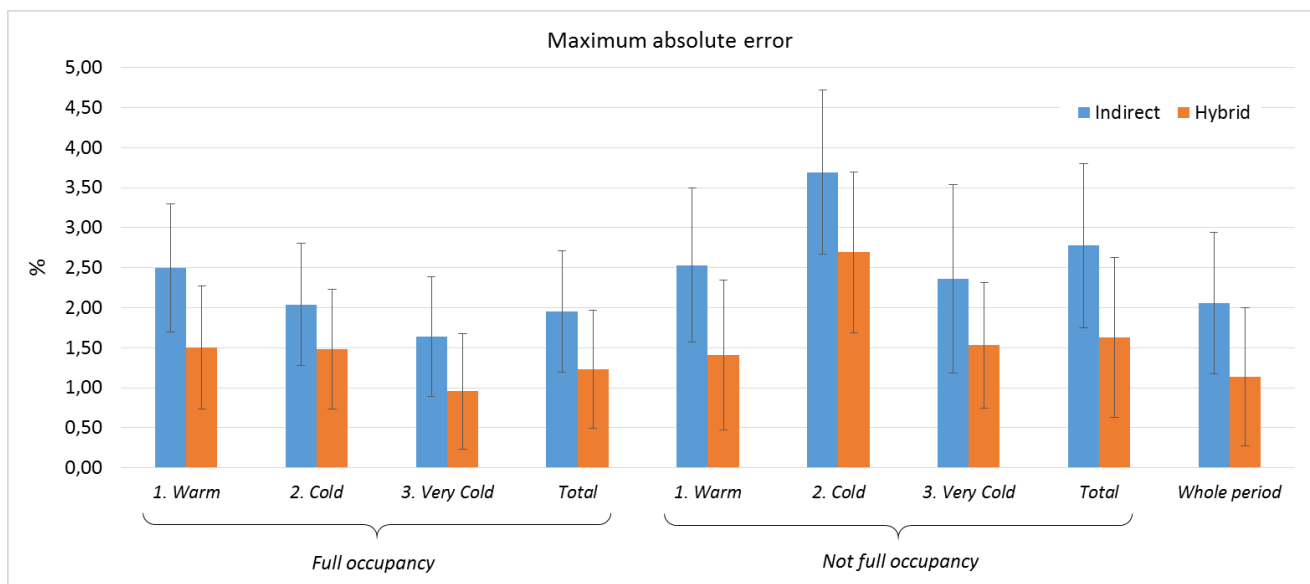

363  
 364 Figure 7 – Maximum error of indirect and hybrid methods

365

366 A tricky issue of indirect heat accounting systems, which can greatly affect their accuracy, is  
 367 represented by the estimation of rated heat output of single radiators. In particular, for two sensors

368 electronic heat cost allocators, which are nowadays the more spread indirect heat accounting systems, a  
 369 resulting rating factor  $K$  must be estimated. This is given by the product of  $K_C$  and  $K_Q$  rating factors,  
 370 which take into account the thermal contact between HCA and radiator surface and the nominal heat  
 371 output of the radiator, respectively. Furthermore, authors investigated the sensitivity of indirect and  
 372 hybrid methods when systematic errors of the estimation of rating factor  $K$  occur. In particular, the  
 373 estimation of  $K_Q$  is a particularly critical issue in the indirect method, especially in existing buildings  
 374 where rated heat output of heating bodies is not always known and certified [21]. To this end,  
 375 systematic fictitious errors (e.g. the possible errors associated to the initial HCA configuration by the  
 376 installer or consequent to a renovation of the thermal plant) were introduced in the heat output of  
 377 radiators and their effects have been evaluated. Figure 8 shows the dependence of standard deviation  
 378 and maximum error of heat accounting with respect to the error of coefficient  $K$  for radiators installed  
 379 in the same vertical raising main (which can be assumed equal to each other). This situation is fairly  
 380 common in buildings with standard apartment types in the different storeys and, therefore, with the  
 381 same configuration and installation leading to highly likely systematic errors (e.g. radiator with the  
 382 same few number of elements in the bathrooms, radiators installed in a niche in the wall, etc.). From  
 383 the analysis of the results it can be pointed out, as predictable, that the hybrid method shows a constant  
 384 accuracy and it is not affected in any way by the aforementioned error, whereas the indirect method  
 385 accuracy shows a linear dependence with the error of  $K$  coefficient.

386

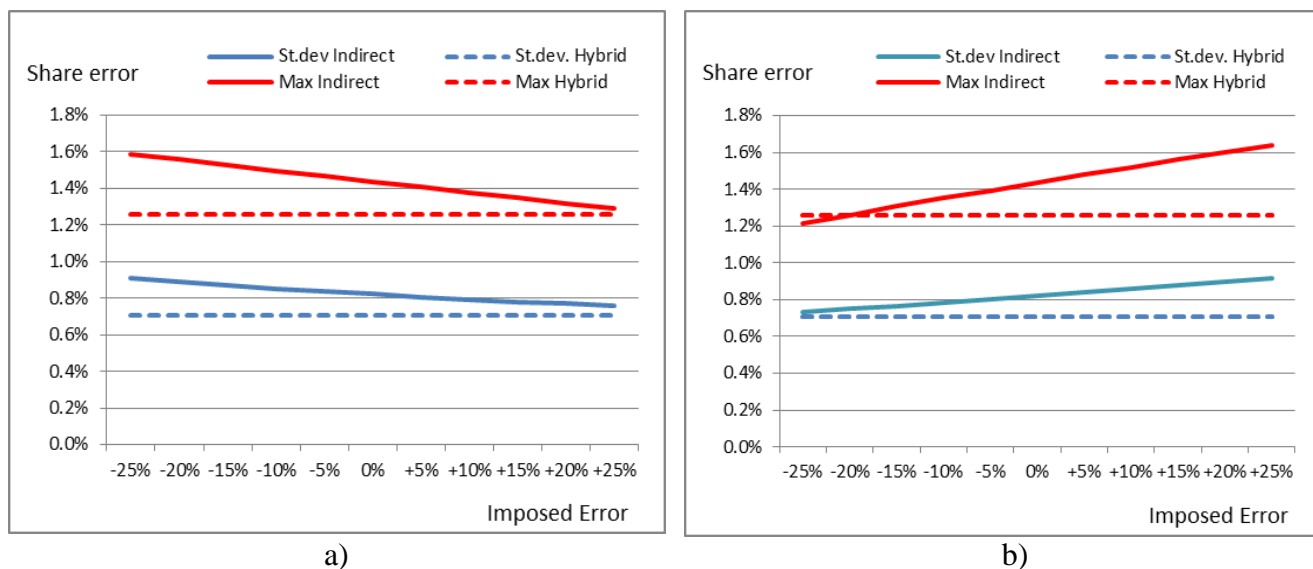

387

388 Figure 8 – Sensitivity analysis of the  $K$  coefficient estimation of radiators: a) error in only one raising  
 389 main (1N), b) error in two raising mains (1N e 3S)

390

391 Authors also evaluated the influence on standard deviation and maximum error of the heat accounting  
392 due to the estimation of the coefficient  $K$  for radiators installed in a single apartment (Figure 9a) and in  
393 two apartments (Figure 9b). This situation occurs, as for example, when a single tenant renovates the  
394 heating system with the replacement of radiators only in few rooms.

395

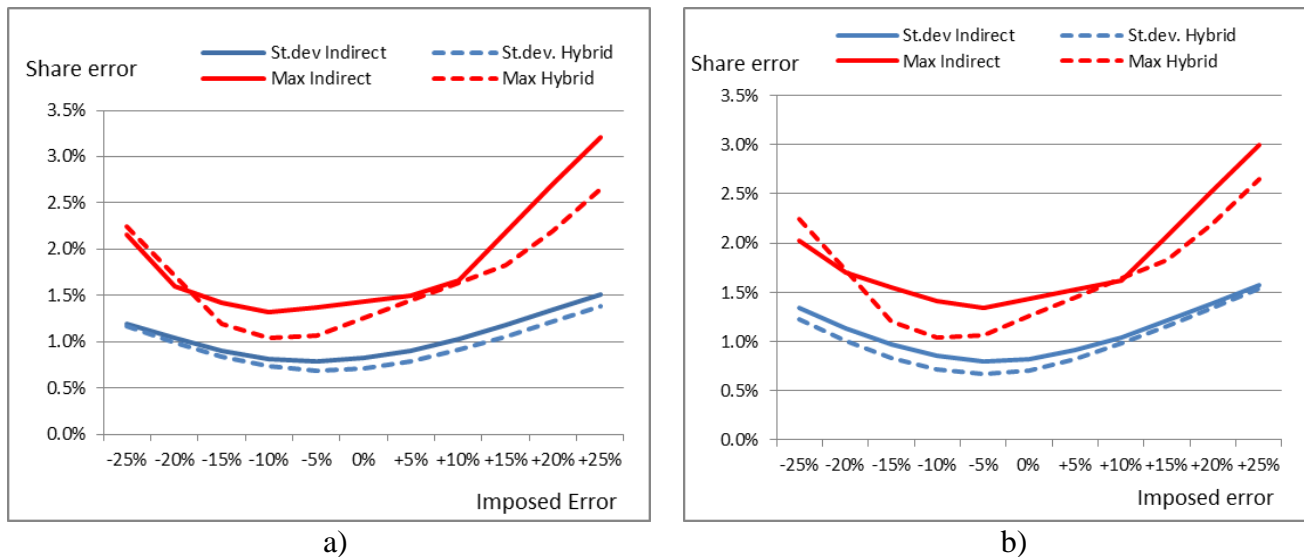

396

397 Figure 9 – Sensitivity analysis of the  $K$  coefficient estimation of radiators: a) error in only one  
398 apartment (Ap\_8), b) error in two apartments (Ap\_7 and Ap\_8)

399

400 From the analysis of the experimental results it can be pointed out that:

- 401 – standard deviation of Hybrid method error is slightly lower and almost similar to the Indirect  
402 method one,
- 403 – maximum error of Hybrid method is basically lower in respect to the Indirect method one, except  
404 under specific conditions (e.g. in the investigated case study, when the error of  $K$  is below -20%  
405 both for the case with one and two apartments).

406 The above described results are consistent to the fact that Hybrid method performs a correction on  
407 single raising mains (i.e. in vertical) and when the error of  $K$  is imposed on a column the effect is a  
408 generalized lower share error in respect to the Indirect method. On the other hand, such correction is  
409 not always effective in some apartments (i.e. in horizontal), in which share error could be randomly  
410 lower or higher. In fact, when the errors of  $K$  are introduced in single apartments (e.g. due to the  
411 replacement of radiators whose heat outputs are not accurately known), larger systematic share errors

412 of Hybrid method in respect to the Indirect one may occur in a completely random way, according to  
413 the number of single accounting devices involved in the radiator replacement in the apartment.

414 In conclusion, the sensitivity analysis shows the hybrid method is basically less affected by the error on  
415 the estimation of coefficient  $K$ , except in few random conditions in which the imposed error is  
416 concentrated in single apartments.

417

418

## 419 **6. Conclusions**

420

421 In this paper the authors proposed a novel “hybrid” method aimed at improving accuracy of heat  
422 accounting in historical buildings supplied by centralized heating systems, by merging the advantages  
423 of indirect method with the higher accuracy typical of direct methods. The on-field accuracy of the  
424 developed method has been experimentally evaluated in comparison with the traditional direct and  
425 indirect ones at INRIM, the primary metrology institute in Italy, in a specially designed experimental  
426 mockup, simulating a virtual four-storey/eight-apartments building.

427 The experimental analysis shows that the proposed hybrid method always performs better than the  
428 indirect one. The advantage can be particularly relevant for buildings presenting standard apartment  
429 configurations and for occasionally occupied buildings.

430 In particular, the experimental results demonstrated that:

- 431 – in the whole investigated period and both for full and occasional occupancy conditions the  
432 standard deviation of accounting errors is equal to 1.22% and 0.89% for the indirect and hybrid  
433 method respectively;
- 434 – when occasional occupation conditions occur, the lowering of both maximum error (reduction  
435 of approximately 41.3%) and  $wRMSE$  (average reduction of about 19.9%) has been found for  
436 the hybrid method with respect to the indirect one;
- 437 – the hybrid method is not affected in any way by the error on the evaluation of the  $K$  coefficient  
438 for radiators installed on the same vertical raising main (e.g. error in the evaluation of the  
439 nominal heat output of radiators of the same type), whereas the indirect method shows a linear  
440 trend;
- 441 – the hybrid method tends to be less affected by the systematic error on the  $K$  coefficient for  
442 radiators installed in the same apartment (e.g. case of the renovation of the heating system) with  
443 respect to the indirect one.

444 The proposed method, therefore, despite the higher cost due to the installation of direct thermal energy  
 445 meters on single vertical raising mains, could be particularly effective in old tower buildings where the  
 446 accurate estimation of the  $K$  coefficients of installed radiators is particularly difficult. It is therefore the  
 447 intention of the authors to perform an experimental campaign aimed at assessing on the field the  
 448 accuracy of the proposed hybrid method in a real building case study.

449

450

## 451 Acknowledgements

452

453 This work has been developed under the projects “Ricerca di Sistema Elettrico PAR 2016” funded by  
 454 ENEA (grant number I12F16000180001) “PRIN Riquilificazione del parco edilizio esistente in ottica  
 455 NZEB” funded by MIUR (grant number 2015S7E247\_002).

456

457

## 458 Acronyms and Symbols

459

EED	Energy Efficiency Directive
HCA	Heat cost allocator
HM	Heat Meter
MID	Measuring Instrument Directive
PLC	Programmable logic computer
St.dev	Standard deviation
$AU_b$	Allocation units of the whole building for the indirect method, dimensionless
$AU'_b$	Allocation units of the whole building for the hybrid method, dimensionless
$AU_{i,j}$	Allocation unit of each $j$ -th radiator in the $i$ -th apartment (indirect), dimensionless
$AU'_{i,j}$	Allocation unit of each $j$ -th radiator in the $i$ -th apartment (hybrid), dimensionless
$AU_i$	Allocation unit of the $i$ -th apartment of the building for the indirect method, dimensionless
$AU'_i$	Allocation unit of the $i$ -th apartment of the building for the hybrid method, dimensionless
$AU_{k,j}$	Allocation unit of the single raising main, dimensionless.
$AU_k$	Allocation units of the single raising main, dimensionless
$E\%_{max}$	maximum relative display deviation, dimensionless
$E_i$	errors of the shares for hybrid and indirect methods
$K_C$	rating factor for thermal contact between HCA and radiator
$K_Q$	rating factor for the nominal thermal power of the radiator
$Q_b$	Total thermal energy consumed in the building, kWh
$Q_i$	Thermal energy consumed by the single $i$ -th apartment, kWh
$Q_{k,j}$	energy consumed in the single raising main, kWh
$Q_k$	Thermal energy supplied along each $k$ -th vertical raising main, kWh

$Q_k$	thermal energy supplied along each vertical $k$ -th, kWh
$R_{AU}$	heat cost allocator display resolution, dimensionless
$S_{HM}$	Individual share of each $i$ -th apartment (reference direct), dimensionless
$S_i$	Individual share of each $i$ -th apartment (indirect), dimensionless
$S'_i$	Individual share of each $i$ -th apartment (hybrid), dimensionless
$\dot{V}$	radiator volumetric flow rate, $m^3 s^{-1}$
$c_p$	specific heat capacity of the heat conveying fluid, $kJ kg^{-1} K^{-1}$
$n_i$	Number of apartments in the building, dimensionless
$n_j^i$	Number of radiators in each $i$ -th apartment, dimensionless
$n_j^k$	Number of $j$ -th radiators installed on the same $k$ -th vertical raising main, dimensionless
$n_k$	Number of vertical raising mains in the distribution plant, dimensionless
$H$	Radiator height, m
$K$	resulting rating factor of the heat cost allocator
$L$	Radiator length, m
$U(E_i)$	expanded uncertainty of errors, dimensionless
$W$	Radiator width, m
$t$	time period, s.
$u(K_Q)$	standard uncertainty of rating factor $K_Q$ , kWh
$u(Q_i)$	standard uncertainty of individual apartments heat consumption, dimensionless
$u(S_{HM,i})$	standard uncertainty of the share ref. thermal energy measurements, dimensionless
$u(Q)$	standard uncertainty of thermal energy measurement, kWh
$wRMSE$	weighted Root-Mean-Square-Error, dimensionless
$\Delta T_{io}$	temperature difference between the inlet and outlet flow section of the radiator, $^{\circ}C$
$\Delta T_r$	Temperature difference between heating fluid and indoor ambient temperature, $^{\circ}C$
$\rho$	density of the heat conveying fluid, $kg m^{-3}$

460

461

462

463 **References**

464

465 [1] Energy Efficiency Directive (EED) European Commission. Directive 2012/27/EU of the  
466 European Parliament and of the Council of 25 October 2012 on energy efficiency, amending  
467 Directives 2009/125/EC and 2010/30/EU and repealing Directives 2004/8/EC and 2006/32/EC,  
468 2012.

469 [2] Directive (EU) 2018/844 of the European Parliament and of the Council of 30 May 2018  
470 amending Directive 2010/31/EU on the energy performance of buildings and Directive  
471 2012/27/EU on energy efficiency, 2018

472 [3] European Committee for Standardization (CEN). EN 1434-1:2016 Heat meters - Part 1: General  
473 requirements. 2015

474 [4] European committee for Standardization (CEN). UNI EN 834:2013. Heat cost allocators for the  
475 determination of the consumption of room heating radiators - Appliances with electrical energy  
476 supply. 2013.

- 477 [5] Italian National Unification. UNI 11388:2015. Heat costs allocation system based on insertion  
478 time compensated by average temperature of the fluid (in Italian language only). (2015).
- 479 [6] Italian National Unification. UNI 9019:2013 Heat costs allocation based on indirect accounting  
480 for the useful thermal energy calculation by insertion time counter compensated with the degree-  
481 days of the building unit. (2013)
- 482 [7] MID directive European Commission. Directive 2014/32/EU of the European parliament and of  
483 the council of 26 February 2014 on the harmonisation of the laws of the Member States relating  
484 to the making available on the market of measuring instruments (recast), 2014
- 485 [8] G.Ficco, A.Frattolillo, A.Malengo, G.Puglisi, F.Saba, F.Zuena. Field verification of thermal  
486 energy meters through ultrasonic clamp-on master meters. *Measurement* (2020), 151,107152
- 487 [9] L. Celenza, M. Dell'Isola, G. Ficco, B.I. Palella, G. Riccio, Heat accounting in historical  
488 buildings, *Energy Build.* 95 (2015) 47–56
- 489 [10] L. Canale, M. Dell'Isola, G. Ficco, B. Di Pietra, A. Frattolillo. Estimating the impact of heat  
490 accounting on Italian residential energy consumption in different scenarios. *Energy and*  
491 *Buildings.* 168 (2018) 385-98.
- 492 [11] M. Dell'Isola, G. Ficco, L. Canale, A. Frattolillo, I. Bertini. A new heat cost allocation method  
493 for social housing. *Energy and Buildings.* 172 (2018) 67-77.
- 494 [12] G. Ficco, L. Celenza, M. Dell'Isola, P. Vigo. Experimental comparison of residential heat  
495 accounting systems at critical conditions. *Energy and Buildings.* 130 (2016) 477-487
- 496 [13] M. Dell'Isola, G. Ficco, F. Arpino, G. Cortellessa, L. Canale. A novel model for the evaluation of  
497 heat accounting systems reliability in residential buildings. *Energy and Buildings* 150 (2017)  
498 281-93
- 499 [14] F. Saba, V. Fernicola, M.C. Masoero, S. Abramo. Experimental Analysis of a Heat Cost  
500 Allocation Method for Apartment Buildings. *Buildings.* 7 (2017).
- 501 [15] C.Marinari, F.Saba, F.Grisotto, M.Orio, M.Masoero. The INRiM thermo-hydraulic mock-up for  
502 thermal energy measurement devices: Design, construction and metrological characterization.  
503 *Energy Procedia* (2015), 78, pp. 2304-2309
- 504 [16] European Committee for Standardization (CEN). EN 442-1: Radiators and convectors - Part 1:  
505 Technical specification and requirements. 2014.
- 506 [17] European Committee for Standardization (CEN). EN 442-2 Radiators and Convectors—Part 2:  
507 Test Methods and Rating. 2014
- 508 [18] G.Betta, M.Dell'Isola. Optimum choice of measurement points for sensor calibration.  
509 *Measurement* (1996), 17(2), pp. 115-125
- 510 [19] JCGM 100:2008 GUM 1995 with minor corrections. Evaluation of measurement data. Guide to  
511 the expression of uncertainty in measurement
- 512 [20] IAPWS R7-97(2012) Revised Release on the IAPWS Industrial Formulation 1997 for the  
513 Thermodynamic Properties of Water and Steam, August 2007
- 514 [21] F.Arpino, G.Cortellessa, M.Dell'Isola, G.Ficco, R.Marchesi, C.Tarini. Influence of installation  
515 conditions on heating bodies thermal output: preliminary experimental results. *Enrgy Proced.* 101  
516 (2016) 74-80.