

Integrating BIM with on site investigation for seismic vulnerability assessment

Original

Integrating BIM with on site investigation for seismic vulnerability assessment / Domaneschi, M.; Villa, V.; Cimellaro, G. P.; Caldera, C.; Zamani Noori, A.; Marasco, S.; Ansari, F.. - 1:(2019), pp. 544-553. (7th International Conference on Computational Methods in Structural Dynamics and Earthquake Engineering, COMPDYN 2019 grc 2019).

Availability:

This version is available at: 11583/2818054 since: 2020-04-29T18:41:38Z

Publisher:

National Technical University of Athens

Published

DOI:

Terms of use:

This article is made available under terms and conditions as specified in the corresponding bibliographic description in the repository

Publisher copyright

(Article begins on next page)

INTEGRATING BIM WITH ON SITE INVESTIGATION FOR SEISMIC VULNERABILITY ASSESSMENT

M. Domaneschi¹, V. Villa¹, G.P. Cimellaro¹, C. Caldera¹, A. Zamani Noori¹, S. Marasco¹, and F. Ansari²

¹ Politecnico di Torino
Corso Duca degli Abruzzi, 24 - Torino
e-mail: marco.domaneschi@polito.it; valentina.villa@polito.it; giampaolo.cimellaro@polito.it; carlo.caldera@polito.it; zamaninoori@gmail.com; sebastiano.marasco@polito.it

² University of Illinois at Chicago
2095 Engineering Research Facility - 842 W. Taylor Street (M/C 246), Chicago, IL 60607-7023
fansari@uic.edu

Abstract

The Italian school buildings asset consists of over 40,000 units. The most (more than 60%) were built before the introduction of the national standard on school buildings and constructions in seismic areas. The present research aims to implement a methodology that consists in an informative modelling for seismic risk analysis. The objective of the activity is to provide the policy makers of an innovative and useful tool for screening the existing building stock, in order to define the priorities of intervention.

The research is divided into several parts. The paper firstly investigates a structured way to collect data for an existing school building, through non-destructive tests (impact hammer - sclerometer, pacometer, thermal camera, accelerometric network) for the reconstruction of the information heritage related to the structures. The existing BIM (building information model) is then integrated with the structural data. The usefulness of implementing the actual BIM LOD (level of detail) or an higher detail level that can represent the new state of knowledge is also investigated to prepare a finite element model.

The subsequent on field acceleration measures are employed both to evaluate the structural modal characteristics and to validate the finite element model. The computation of the vulnerability coefficient of the structure in accordance with the new Italian standard is the last step of the analysis.

Keywords: BIM, monitoring, FEM, seismic vulnerability, school building

1 INTRODUCTION

Building Information Modelling (BIM) is a methodology that is radically changing the construction sector, and in recent decades is spreading as a management methodology, thanks to the studies of Eastman [1] and both to the continuous innovation of technological and information infrastructure. It can support planning and cost estimation, management of design changes, visualization and simulation of design ideas, management of construction and maintenance. The potential of Building Information Modeling for seismic risk analysis is closely related to BIM as a relational database of building information.

Much recent research is focused on the Facility Management (FM) phase for the management of existing buildings [2,3]. Some of these studies focus on the use of sensors for monitoring and controlling parameters for building uses [4]. BIM represents the future of building management and can have enormous potential for seismic risk calculation, because it is a database containing all information on the vulnerability of structural and non-structural components [5]. Some research has begun to define ways in which BIM could help in seismic risk assessment and mitigation. [6].

The Italian school building stock consists of more than 40,000 buildings, mostly constructed before the introduction of the technical regulation on school building (DM 18/2/1975) and before the definition of special requirements for seismic areas (Law no. 64/1974) [7]. In summary, it was found that only 48.5% of Italian school buildings have a static certification, 56% have a static certificate of suitability and only 10.1% are built according to anti-seismic safety criteria. At the end of this brief overview, 50.13% of school buildings on Italian territory are located in seismic areas with a medium-high level of danger [8].

2 OBJECTIVES AND METHODOLOGY

Nowadays BIM is a methodology that is been implementing into construction process with the aim of managing the entire LCA of building. BIM models are made for new buildings at the design stage and are not always structured to support the execution and subsequent operational and maintenance (O&M) phases. The models for existing buildings, on the other hand, often concentrate on the precise reconstruction of very complex geometries, such as in many cases HBIM, or on systematizing the documentation and data relating to the building materials.

In the case of existing infrastructures such as schools, many studies are focused on the BIM modeling for the energy assessment and for the design of upgrading interventions [9]. The data contained in the models are therefore linked to the architectonic, plant engineering and energy fields [10]. The BIM model hardly contains structural information that can be used and processed with FEM analysis software.

Before carrying out any intervention on existing buildings the priority is to verify the structural stability and seismic vulnerability to avoid investments on dangerous or inefficient constructions. This is even more strategic when it comes to public buildings as schools. In recent years, there has been a need to assess the seismic vulnerability of the Italian school heritage, built largely without specific seismic safety regulations, with codes that have been exceeded for decades and with insufficient maintenance activities.

For this reason, this research aims to define guidelines for structural BIM modelling of existing buildings, by means of which existing or new BIM models can be integrated with details, information and structural characteristics that allow to easily (e.g., through plugins) derive a structural model (e.g., finite element) by which the seismic vulnerability can be calculated.

In order to identify the essential information for the seismic vulnerability analysis, the levels of graphic detail (LOG) and information detail (LOI) defined by the literature and the regulations are evaluated [11]. The data are collected from the early stages of design and, with the evolution and definition of the design details, they are improved and their degree of reliability is improved [12]. At the construction phase, all the information relating to materials, laying methods and on-site tests become final and useful for the serviceability stage and the building maintenance. Among all these data there are some of strategic importance for the calculation of the seismic vulnerability index. As an example, an information sheet is given for a reinforced concrete pillar cast in situ where, in the Hand-Over and Close-Out phase, the information necessary for FEM analysis is highlighted (Table 1).

GUIDELINE FOR BIM MODELLING OF STRUCTURAL ELEMENTS - IN-SITU CONCRETE COLUMN					
LOG					
		Concept and Developed Design	Technical Design	Construction Design	Hand-Over and CloseOut
					
LOI					
Dimensions	<i>b</i>	X	X	X	X
	<i>h</i>	X	X	X	X
	<i>Materials</i>	X	X	X	X
Concrete properties	<i>Analytics Model</i>	-	X	X	X
	<i>CLS - Concrete strength class</i>	-	X	X	X
	<i>CLS - Concrete exposure class</i>	-	X	X	X
	<i>CLS - Concrete consistency class</i>	-	X	X	X
	<i>CLS - Chloride content class</i>	-	X	X	X
	<i>CLS - Maximum diameter of aggregates</i>	-	X	X	X
	<i>CLS - Minimum cement dosage</i>	-	-	X	X
	<i>CLS - Max water/cement ratio</i>	-	X	X	X
	<i>CLS - Trapped air (max value)</i>	-	-	X	X
	<i>CLS - Cement properties</i>	-	X	X	X
	<i>CLS - Mixing water properties</i>	-	X	X	X
Steel properties	<i>Long. rebars - Armor area current section</i>	-	-	X	X
	<i>Long. rebars - Number of primary reinforcement bars</i>	-	-	X	X
	<i>Long. rebars - Diameter of primary reinforcement bars</i>	-	-	X	X
	<i>Stirrups - Number of secondary reinforcement brackets</i>	-	-	X	X
	<i>Stirrups - Step brackets secondary reinforcement</i>	-	-	X	X
	<i>Stirrups - Diameter of secondary reinforcement brackets</i>	-	-	X	X
	<i>Stirrups - Step brackets to the supports</i>	-	-	X	X
	<i>Min. steel cover thickness</i>	-	X	X	X
	<i>Type of steel reinforcing bars</i>	-	X	X	X
	<i>Type of steel reinforcement brackets</i>	-	X	X	X
	<i>Properties steel reinforcing bars</i>	-	X	X	X
	<i>Properties steel reinforcement brackets</i>	-	X	X	X

Table 1: Information sheet of a reinforced concrete pillar.

With the traditional collection and archiving system, not always during the life of the building, the Clients properly store all the documents and data of the project and its realization (technical sheets, drawings, certificates, etc.). In the case of particularly old public buildings, it is quite frequent not to find structural and testing projects. For this reason, it is essential to understand what information is necessary for the construction of FEM models. If necessary, these can be collected after by means of non-destructive and reconstructive tests (sclerometric, pacometric tests, etc.).

Revit analytical model

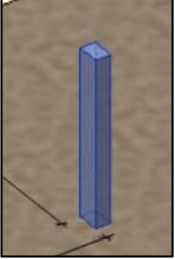
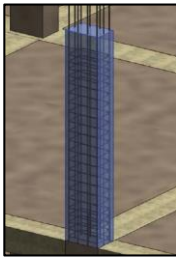
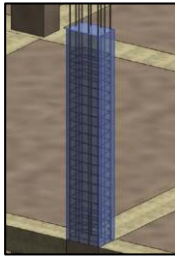
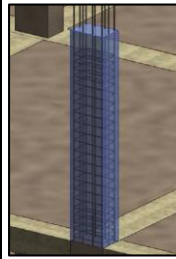
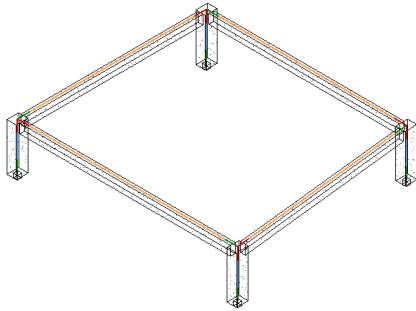

Revit material sheet

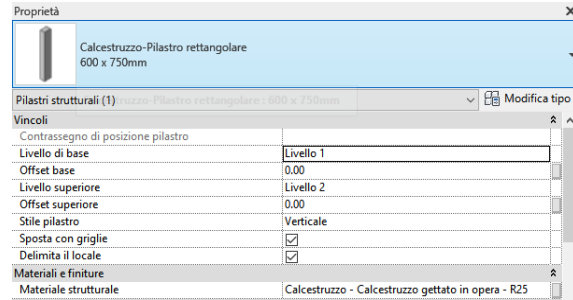

Revit 3D model

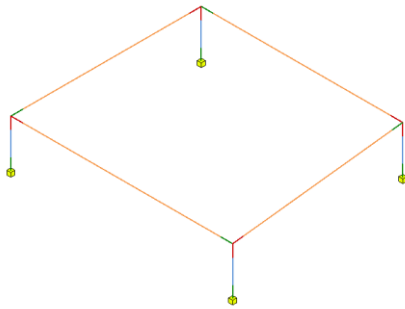

SAP model

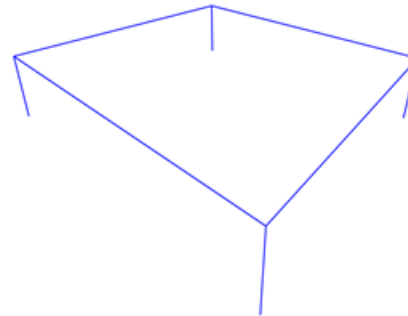

Figure 1 : Example of extrapolation from Revit to SAP.

Once the BIM model has been implemented according to the guidelines just discussed and described in detail below, it is easy to transfer the BIM to a FEM software. The structural model is then validated through on field dynamic vibration tests. In particular operational modal analysis allows to identify the natural frequency and mode shapes. The vulnerability index can be finally assessed following the current prescription from Italian standard.

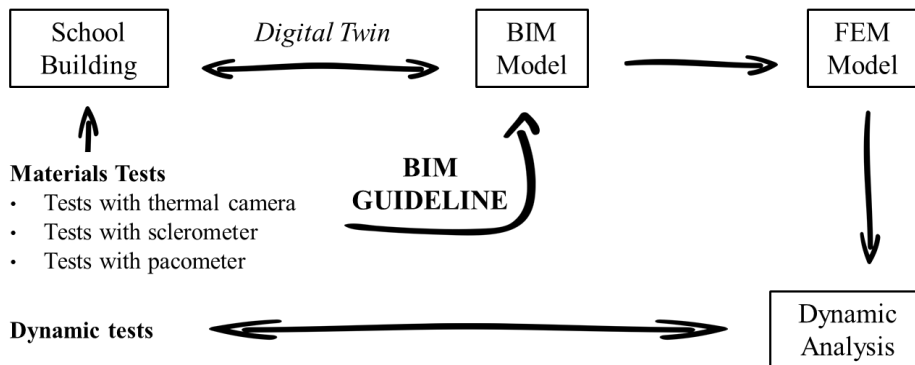

Figure 2 : Scheme of methodology applied

In this way, the proposed methodology may allow the decision-makers to face a complex scenario with a tool that can streamline the procedure by identifying the most dangerous situations, those ones where further investigation is needed or where no intervention is necessary.

3 GUIDELINES

Guidelines for BIM modelling have been drawn up in order to give indications to BIM modelers and to obtain a BIM model that can be used for dynamic structural analyses. CSIxREVIT is the available plug-in to extrapolate from the Revit BIM model the SAP or ETABS Codes.

The main shortcomings observed when analyzing existing BIM are the lack of material definition of structural elements, the inaccuracy in the definition of beams and pillars that respond more to architectural needs on BIM rather than to structural ones. Similarly, also the inaccuracy in the definition of the boundary conditions.

Therefore, the following points are suggested to the BIM developers in order to be able to easily extrapolate from Revit into a structural model that may be useful for vulnerability analyses. In particular it is necessary to essentially define in Revit:

- the type of material of all structural elements
- the precise geometry of all elements: the cross-section for all drawing elements such as beams or the thickness in the case of wall and floor shells.
- The kinematic constraints and the connection between the various structural elements to satisfy compatibility and consistency.
- The loading distribution for all structural elements. These are the structural dead loads (weight of building materials, concentrated masses, e.g. machinery, etc.).

4 CASE STUDY

The “Mascagni School” is a reinforced concrete building located in Melzo (MI) built in 1976. The school consists of three separated structures including classes, gym and canteen. Figure 3 shows the overall view of the school. Only the main building including the classes is analyzed in this report.



Figure 3. (a) Building overall view, (b) classes, and (c) gym building

The main structure (Classes) is a two stores building with a rectangular plan about 98.5m x 20 m and the height of 6.8 m. This building is composed of three different blocks separated by two expansion joints (Figure 4). During the inspection, it was observed that the space in expansion joints is about 3cm filled with polystyrene material.

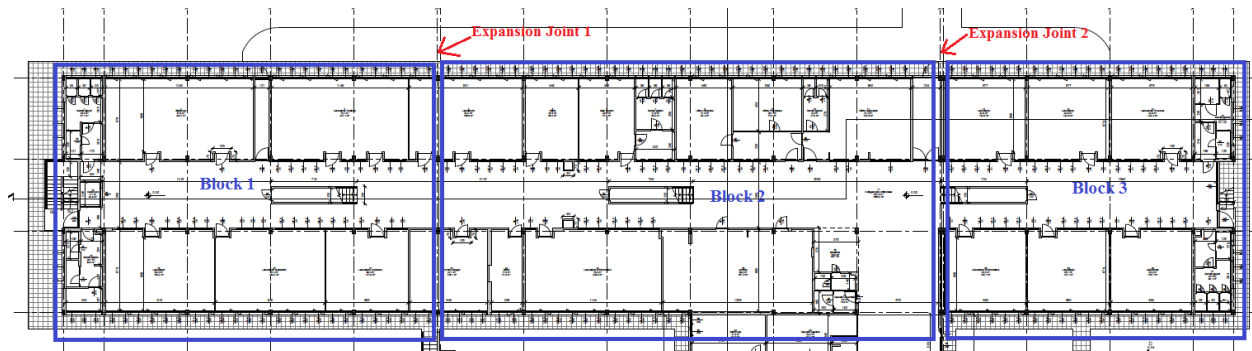

Figure 4: Expansion joints configuration of main building (classes)

4.1 Materials tests

The only available information about the school can be found in a BIM model (created by Politecnico di Milano), while it lacks a lot of information to create a detailed FEM model. Therefore, a site inspection was performed on November 14th 2018 to get the required data. A series of non-destructive tests were conducted to obtain the structural parameters such as module of elasticity and material strength (using sclerometer), test with thermal camera (to identify the structural elements), test using pacometer (to specify the element reinforcement). Finally, the obtained information was used to integrate the BIM model.

4.2 Tests with thermal camera

Thermal camera was used to detect the hidden structural elements such as columns and beams. The device is an infrared camera able to detect the different degrees of irradiation emitted by the different surface materials. Figure 5a shows an example of the test performed in canteen building identifying beams and column. The concrete elements (blue areas) have a lower temperature with respect to the masonry elements, lighting systems and aluminium ventilation elements (orange and yellow areas).

4.3 Tests with sclerometer

To have some indications on the materials strength, non-destructive tests have been performed with sclerometer. This device measures the rebound value R . Using the conversion tables, it is possible to determine the value of the compressive strength based on the magnitude of the measured rebound. The concrete to be examined must be free from any coatings (such as a column) to show the surface of the elements. The test was performed directly on the beams and columns surfaces since they were not covered fully with any material (Figure 5b). E.g., the test was performed to determine the strength of two columns located at the ground floor. They have two different dimension (25x50cm and 30x50cm) as representative of the typical columns of the building. The results show that the average concrete strength of the columns is equal to 31.5 MPa. Therefore, the concrete class C25/30 can be used to integrate the BIM.

4.4 Tests with pacometer

A pacometer was used to get information about the reinforcement inside the reinforced concrete elements, such as location, cover and size of steel reinforcement bars. The tests consist in the measurement of the magnetic field determined by the presence of steel reinforce-

ments near the concrete surface of the structural elements. E.g., the two typical columns used for the test with the sclerometer were tested (Figure 5c).



Figure 5: a) Constructional element identification using thermal camera; b) data acquisition with sclerometer; c) Measurements with pacometer

4.5 Dynamic tests

The validation of the FE model of the school building, as extrapolated from the BIM, has been performed by means of dynamic tests [13,14]. A wireless sensor network has been employed for collecting acceleration records in different positions on the school building. It consists in both MEMS and force balance triaxle acceleration sensors (Figure 6a).

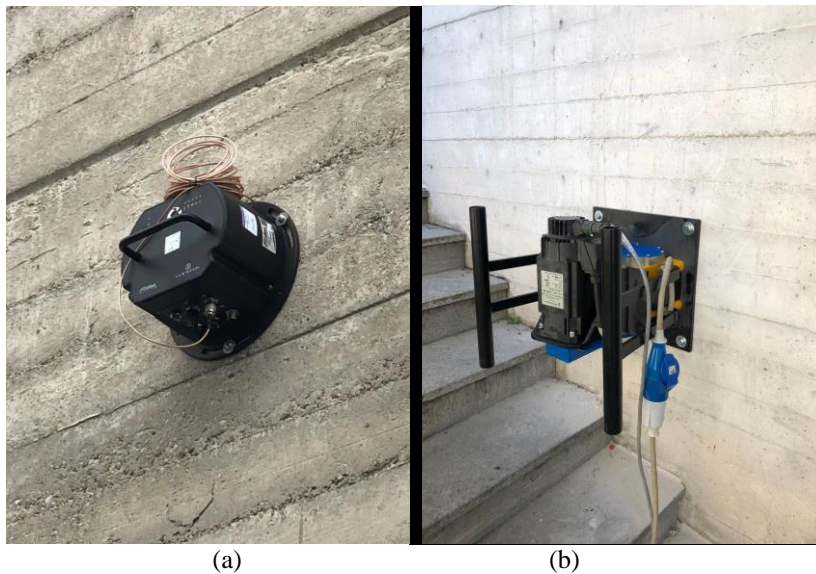

Figure 6: (a) MEMS sensing unit of the wireless sensor network and (b) the vibrodine.

To assess the efficiency of the different type of accelerometers both ambient vibration tests and forced dynamic tests have been performed. In the last case a vibrodine facility able to apply harmonic forces on the structure has been employed. It has been applied to a reinforced concrete element, the elevator containment (Figure 6b).

The finite element model has been validated by comparison with the natural vibrations frequencies as identified from the dynamic tests. Table 2 summarizes as example the comparison for the first block of the school building in the north direction.

SOFTWARE	Block 1 (Acc. # 54)	
	Mode 1	Mode 2
	[Hz]	[Hz]
MATLAB	9	14,6
GEOPSY	9,18	14,15
SAP 2000	7,98	19,1

Table 2: Comparison of the natural frequencies between the dynamic tests and the FEM model.

4.6 From BIM to FEM

Following the BIM guideline described before, the School BIM model was implemented and the SAP model is extrapolated through the plug-in. Figure 7 highlights the case study of the main school building (where classes are located) of the case study in the hinterland of Milan.

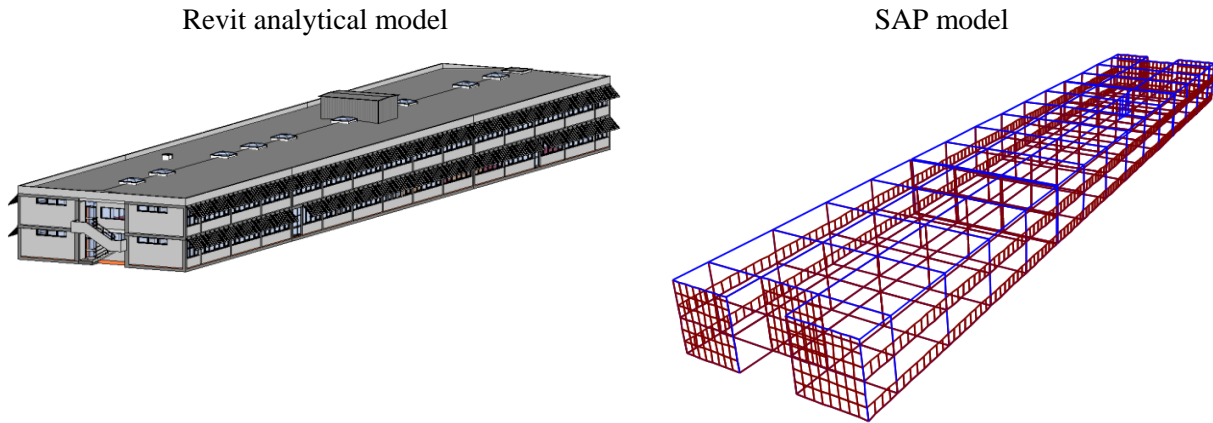

Figure 7 : Mascagni School in Melzo, Milan.

4.7 Seismic vulnerability

The characteristic of a structure to suffer a certain level of damage facing a given seismic event is termed as *vulnerability*. Following the current Italian technical prescription, the assessment of seismic vulnerability for all public buildings is required to their redevelopment, with particular reference to schools. The parameters that can influence seismic vulnerability are the structural type, age of construction, number of floors and maintenance status of the building. In particular, the following vulnerability index is reported:

$$\zeta_E = \frac{F^*}{F_{NTC}}$$

Where F^* is the maximum bearable seismic action and F_{NTC} is the seismic action that should be used for designing the same structure accordingly with the current Italian standard DM NTC 2018. The value at the numerator can be computed through different methodologies at increasing complexity. For regular structures, static nonlinear analyses (pushover) could be selected. The transition from the linear range could be selected as the maximum bearable seismic action. However, it is worth noting how the standard does not give any other

prescription about modelling and it can be interpreted as an implicit recognition of the uncertainties of the problem and the singularity of each structure.

The evaluation of the seismic capacity for the structure should allow estimating a safety margin moving the problem from the seismic hazard characterization at the site to the structural fragility. Such perspective could be also useful for the national authority for tracing the general condition of the existing building asset, built often more than fifty years ago, in times when earthquake engineering was less developed.

5 CONCLUSIONS

This research shows the importance of a BIM modelling guideline in order to have a BIM model that could be easily used for seismic analysis. Usually, for instance the BIM model case study had some interoperability problems and needed some modifications before using it for analysis.

The methodology proposed in this paper and validated with the case study can be applied for a faster and more efficient assessment of the seismic vulnerability coefficient of the building stock. This is a huge support tool for managers and owners to effectively assess priorities for action, based on deficiencies and seismic risk.

ACKNOWLEDGMENTS

The research leading to these results has received funding from the European Research Council under the Grant Agreement n°ERC_IDEalreSCUE_637842 of the project IDEAL RESCUE - Integrated DEsign and control of Sustainable CommUnities during Emergencies.

Maria Vittoria Pietropinto performed some of the analyses in partial fulfilment for the requirements of the Bachelor's Degree in Civil Engineering at Politecnico di Torino, under the guidance of the Authors. Her contribution is gratefully acknowledged.

REFERENCES

- [1] Eastman, C., Teicholz, P., Sacks, R., Liston, K. (2011) BIM Handbook: A Guide to Building information modeling for owners, managers, designers, engineers and contractors – 2nd Edition. Wiley, Hoboken, New Jersey.
- [2] Volk, R., Stengel, J., Schultmann, F. (2014) Building Information Modeling (BIM) for existing buildings – Literature review And future needs. *Automation in Construction* 38: 109–127.
- [3] Bercerik-Gerber, B., Jazizadeh, F., Li, N., Calis, G. (2012) Application areas and data requirements for BIM-enabled facilities management. *Journal of Construction Engineering and Management*, 138 (3): 431-442.
- [4] Dong, B., O'Neill, Z., Zhengwei, L. (2014) A BIM-enabled information infrastructure for building energy Fault Detection and Diagnostics. *Automation in Construction*, 44: 197-211.
- [5] FEMA report (2006), "Next-Generation Performance-Based Seismic Design Guidelines: Program Plan for New and Existing Buildings".

- [6] David P. Welch, T. J. S. (2014) Potential of Building Information Modelling for Seismic Risk Mitigation in Buildings. *Bulletin of the New Zealand Society for Earthquake Engineering*, 47(4), 253–263.
- [7] Tagliabue, L. C., & Villa, V. (n.d.). *Il BIM per le scuole Analisi del patrimonio scolastico*. (HOEPLI, Ed.). Milano.
- [8] Villa, V., Domaneschi, M., Cimellaro, G. P., Caldera, C. (2018), BIM-based approach for seismic risk analysis. Shiao, J., Vimonsatit, V., Yazdani, S., and Singh, A. *Streamlining Information Transfer between Construction and Structural Engineering (ASEA-SEC-4)* ISBN 978-0-9960437-7-9
- [9] Di Giuda, G. M., Villa, V., Tagliabue, L. C., Giana, P. E., Rinaldi, S., Ciribini, A. L. C. (2018) Refurbishment and school buildings management in a smart building environment. *Technologies and Materials For Renewable Energy, Environment And Sustainability: TMREES18*, 1-8. ISBN: 978-0-7354-1675-8
- [10] Moretti, N., Mainini, A. G., Tagliabue, L., Maltese, S., Dejacco, M. C., Villa, V., Di Giuda, G. M., Poli, T., Ciribini, A. L. C., De Angelis, E., Hakim, S., Re Cecconi, F. (2017) Data-driven energy retrofit per gli edifici scolastici School buildings data driven energy retrofit. *Colloqui AT.e 2017 - Demolition or Reconstruction?* 1121-1131 ISBN: 978-88-96386-58-3
- [11] Di Giuda, G. M., Villa, V., Loreti, L. (2016) Definition of Incremental Information Data for BIM-based Project. *Back To 4.0: Rethinking The Digital Construction Industry*, 29-38. ISBN: 978-88-916-1807-8
- [12] Di Giuda, G. M., Maltese, S., Re Cecconi, F., Villa, V. (2017). Il BIM per la gestione dei patrimoni immobiliari. Linee guida, livelli di dettaglio informativo grafico (LOD) e alfanumerico (LOI), HOEPLI. ISBN: 9788820381639
- [13] Domaneschi, M., Sigurdardottir, D., Glišić, B. (2017) Damage detection based on output-only monitoring of dynamic curvature in concrete-steel composite bridge decks. *Structural Monitoring and Maintenance*, 4(1): 1-15.
- [14] Cimellaro, G.P., De Stefano, A. (2014) Ambient vibration tests of XV century Renaissance Palace after 2012 Emilia earthquake in Northern Italy. *Structural Monitoring and Maintenance*, 1(2). DOI: <http://dx.doi.org/10.12989/smm.2014.1.2.000>