

Some aspects on 3D base isolation of heavy and lightweight structures with TMD

Original

Some aspects on 3D base isolation of heavy and lightweight structures with TMD / Domaneschi, M.; Martinelli, L.; Cimellaro, G. P.. - STAMPA. - 1:(2019), pp. 2034-2045. (Intervento presentato al convegno 7th International Conference on Computational Methods in Structural Dynamics and Earthquake Engineering, COMPDYN 2019 tenutosi a Crete (Greece) nel 24 June 2019 through 26 June 2019) [10.7712/120119.7056.19945].

Availability:

This version is available at: 11583/2818052 since: 2020-04-29T18:12:09Z

Publisher:

National Technical University of Athens

Published

DOI:10.7712/120119.7056.19945

Terms of use:

This article is made available under terms and conditions as specified in the corresponding bibliographic description in the repository

Publisher copyright

(Article begins on next page)

SOME ASPECTS ON 3D BASE ISOLATION OF HEAVY AND LIGHTWEIGHT STRUCTURES WITH TMD

Marco Domaneschi¹, Luca Martinelli², Gian Paolo Cimellaro³

¹ Politecnico di Torino DISEG

marco.domaneschi@polito.it

² Politecnico di Milano DICA

luca.martinelli@polimi.it

³ Politecnico di Torino DISEG

gianpaolo.cimellaro@polito.it

Abstract

Some aspects related to the 3-D base isolation of structures are presented in this paper through a numerical approach. A traditional horizontal base isolation system with the use of high damping rubber bearings (HDRB) is coupled with a tuned mass damper (TMD) in the vertical direction. Both lightweight (e.g. artworks or special equipment) and massive structures (a nuclear power plant building) have been considered and possible positive and negative aspects from the implementation of the proposed hybrid control strategy are investigated. It is found that the TMD is able to provide a reliable source of energy dissipation, and to control the vertical motion of the structure, only when this has a low value of damping. For damping values that approximately exceed the 5% limit, the positive effects of TMD are negligible, if not worsening.

Keywords: 3D base isolation, TMD, HDRB, vertical mitigation, three dimensional ground motion, lightweight and heavy and structures

1 INTRODUCTION

The approach of using Base Isolation to control the seismic response of a structure has by now become a mature and well established one [1-3].

Base Isolation assumes insertion of specifically designed deformable devices (isolation bearings) between the structure of interest (the superstructure) and its foundations to shift the fundamental period of the superstructure above the predominant period of the ground motion.

The most common application of Base Isolation takes into account the lateral movement of the superstructure, and adopts laterally flexible isolation devices to shift the superstructure fundamental period typically in the range from 2 to 4 seconds. However, since such long periods imply large relative displacements across the isolation devices, a form of energy dissipation is normally introduced. Base Isolation with respect to the lateral motion has been the subject of a vast amount of published research and has become an accepted and standardized approach in several seismic design codes (e.g. [4]).

The concept of Seismic Isolation applied to the vertical component of the structural motion has, instead, received a much more limited attention. The first proposals were formulated in the late 80s, early 90s of the last century (e.g., [5]), and appeared related to the vertical isolation of part of a floor, mainly to protect valuable light weight equipment (see [6-8]). These early proposals were mainly based on mechanical devices. Full-scale tests, carried out on shaking tables, pointed out as the performance was less than that associated at the time to horizontal isolation, because of the vertical frequency of the system being not low enough due to the cost and size of the required isolation devices.

More recently, the idea of the vertical isolation of a building has surfaced again in two very different fields: namely, in relation to the protection of Nuclear Power Plants and of small historical objects (e.g. [9,10]).

Isolation in vertical direction, coupled to horizontal base isolation, is known in the nuclear community also as "3D isolation". A recent review of several vertical isolation devices for NPPs can be found in [11]. The Vertical Base Isolation (VBI) of Nuclear Power Plants (NPPs) has been studied, besides in the USA and in Japan, also in Korea [12], fostered by the effects that the vertical component of near field earthquakes that can have on NPPs.

VBI can be implemented either using integrated isolation solutions, in which a single device provides isolation with respect to all three ground motion components, or by adding a localized vertical isolation component in series to a device that provides isolation with respect to the horizontal motion components [6]. At any rate, as it happens for lateral isolation, by decreasing the vertical frequency the acceleration in the superstructure are decreased, while the relative displacements across the isolators are increased. An appropriately high value of damping can help controlling the relative displacements, especially in the low frequency range.

2 METHODOLOGY

In this paper two types of integrated isolation solutions are dealt with: elastomeric-bearings and vertical metallic springs. Elastomeric bearings can be classified as low damping or high damping bearings, depending on the damping capabilities of the rubber they are made of.

The stiffness and energy dissipation of high damping bearings is highly nonlinear and depends on the level of shear strain. The effective damping of these devices can reach 10 to 15 % of the critical.

The low damping bearings exhibit an almost linear characteristic with damping values in the range of 2 to 5 % of critical in the lateral direction. They decrease to lower values if the vertical direction is analyzed. This topic is considered in this preliminary study.

Metallic springs have typically a very small damping, since they have to stray into the elastic range of the material, and hence need an additional source of damping in horizontal and vertical direction.

In this preliminary work we focus only on the vertical motion of the superstructure and on providing the required amount of damping in the vertical direction by means of a properly tuned Tuned Mass Damper (TMD).

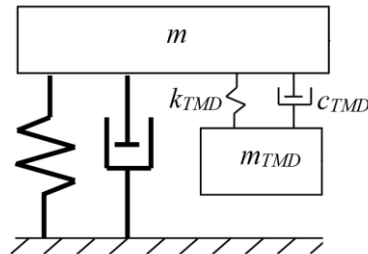

Figure 1: Linear dynamic model for the vertical motion of the superstructure with mass m and the TMD.

The Tuned Mass Dampers used to passively control the superstructure consist in a mass attached to the superstructure with a spring and a damper (Figure 1). The control exerted by the TMDs can be classified as passive, since the TMDs work as passive energy dissipation devices, providing the damping required to the VIS.

The damper in the TMD dissipates energy whenever the mass of the TMD oscillates relative to the superstructure. In order to ensure this motion the TMD is carefully tuned so that its natural frequency is close to one relevant modal frequency of the base isolated system.

The energy transferred from the superstructure to the TMD generates large oscillations of the mass of the TMD, to the point that this aspect can become a limiting one in the design of the TMD.

Due to the quasi-resonance between the controlled mode of the base isolated system and the TMD, required for the functioning of the TMD system, this last operates efficiently only in a narrow frequency band. That is the frequency of the harmonic input or, in case of wide frequency input, the main natural frequency of the structure. Therefore, the TMD mitigates only the vibration mode it is tuned to.

One of the earliest theory for the design of TMD was presented by Den Hartog in his well known book [13], where the optimal parameters (natural frequency and damping ratio) of a TMD that minimizes the displacement of the primary structure (here the superstructure) were obtained by means of the so called *fixed-points method*. The primary structure is supposed to have vanishing structural damping. Optimal parameters for a wider list of minimization objectives, also obtained by the fixed-points method, were later reported in [14], also for vanishing damping of the primary structure. Empirical formulas for several minimization objectives were given by Ioi and Ikeda [15] while approximate, analytical closed-form, and series solution for the case of non-vanishing damping of the primary structure can be found in [16] for mono-frequency and white noise input.

Optimization of the TMDs parameters in the case of earthquake type excitation was presented in [17] for an earthquake excitation modelled by a stationary stochastic process with a power spectral density of the Kanai-Tajimi type [18,19].



By properly selecting the frequency ω_g and damping ζ_g of the Kanai-Tajimi filter, different spectral density shapes can be represented. For the fitting of real earthquake accelerations ω_g has been found in the range 3 to 12 Rad/s. The value of the frequency ω_g and the damping ζ_g

associated to the EC8 [4] elastic response spectra can be found in [20.21], along with a closed form expression for the elastic response spectra derived from this PSD.

3 ADOPTED CASE STUDIES FOR PRELIMINARILY TESTS

The preliminary study is focused on both heavy and lightweight structures represented by a nuclear power plant (NPP) building and a statue. This last one is a real statue case study with the geometric and mass properties reported in Table 1. It has been considered rigidly connected to the support that is base isolated on four helicoidal metallic springs with 109 and 122 kN/m as horizontal and vertical stiffness respectively. The intrinsic damping is extremely low (about 0.1% in both directions).

Table 1: Considered statue as case study of lightweight structure.

Statue Name	Location	Mass [kg]	Footprint [m]		Height [m]	Center of the mass [m]			Photograph	
			x	y		x	y	z	y-z	x-z
Zuccone (Donatello)	Museo dell'Opera del Duomo	576	0.55	0.41	1.99	0.27	0.19	0.91		

The considered NPP building is the IRIS medium power (335 MWe) pressurized light water reactor whose preliminary design has been developed by an international consortium which includes more than 20 partners from 10 countries. In a tentative design (see Figure 2), the introduction of an isolation system was considered; the system is made by 120 HDRB devices installed between the foundation slab and the base [2].

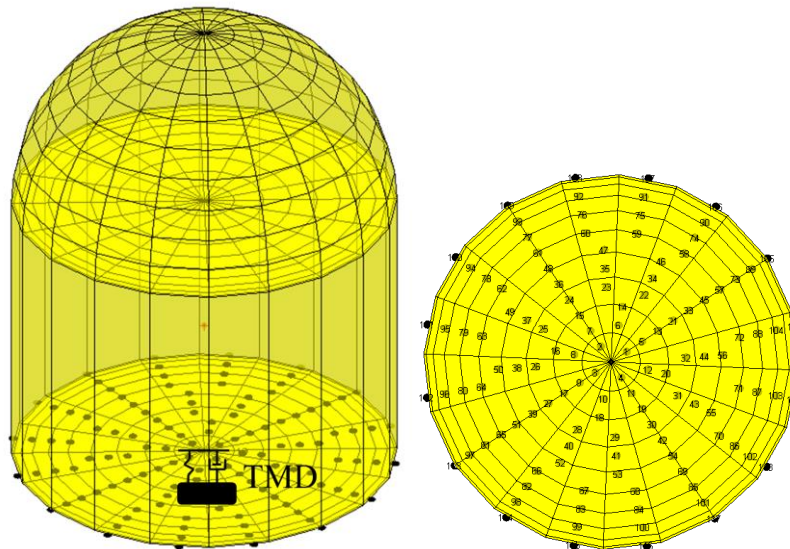
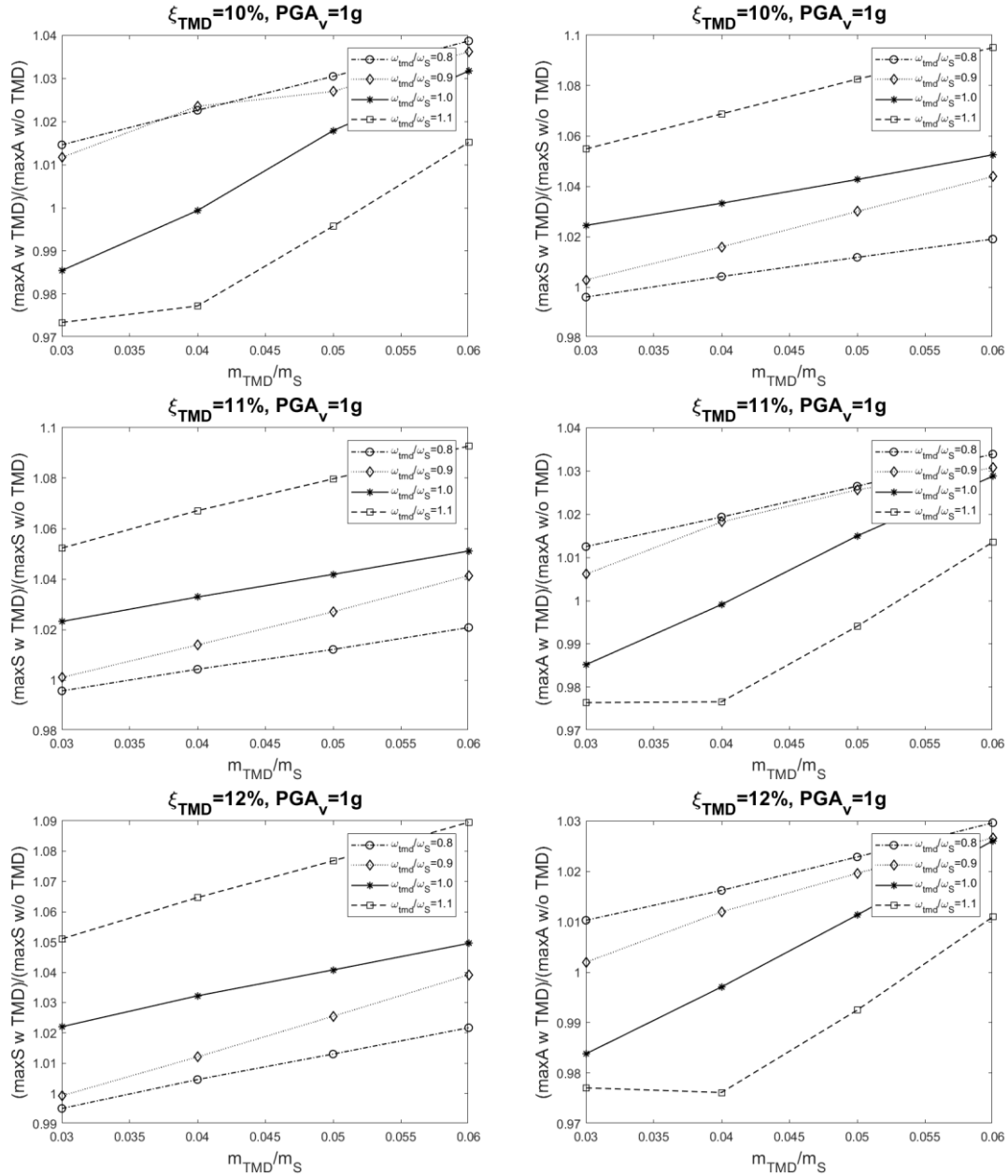

Figure 2: Base isolated NPP model: (a) NPP layout and the TMD on the vertical direction at the center of mass. (b) Top view of the isolation layer.

The isolators are made of alternated rubber layers and steel plates, bonded through vulcanization. Damping factors intrinsic to this technology ranges generally from 10% to 20%, while shear modulus lies in the 0.8–1.4 MPa range.

4 RESULTS

The preliminary analysis of the structures has been performed by the direct integration of the equation of motion for the 2DOFS in Figure 1. The seismic input in the vertical direction has been fixed to 1g PGA with the aim of possible generalizations due to the intrinsic linearity of the numerical model. It has been selected compatible to the USNRC 1.60 response spectra, as in [2].



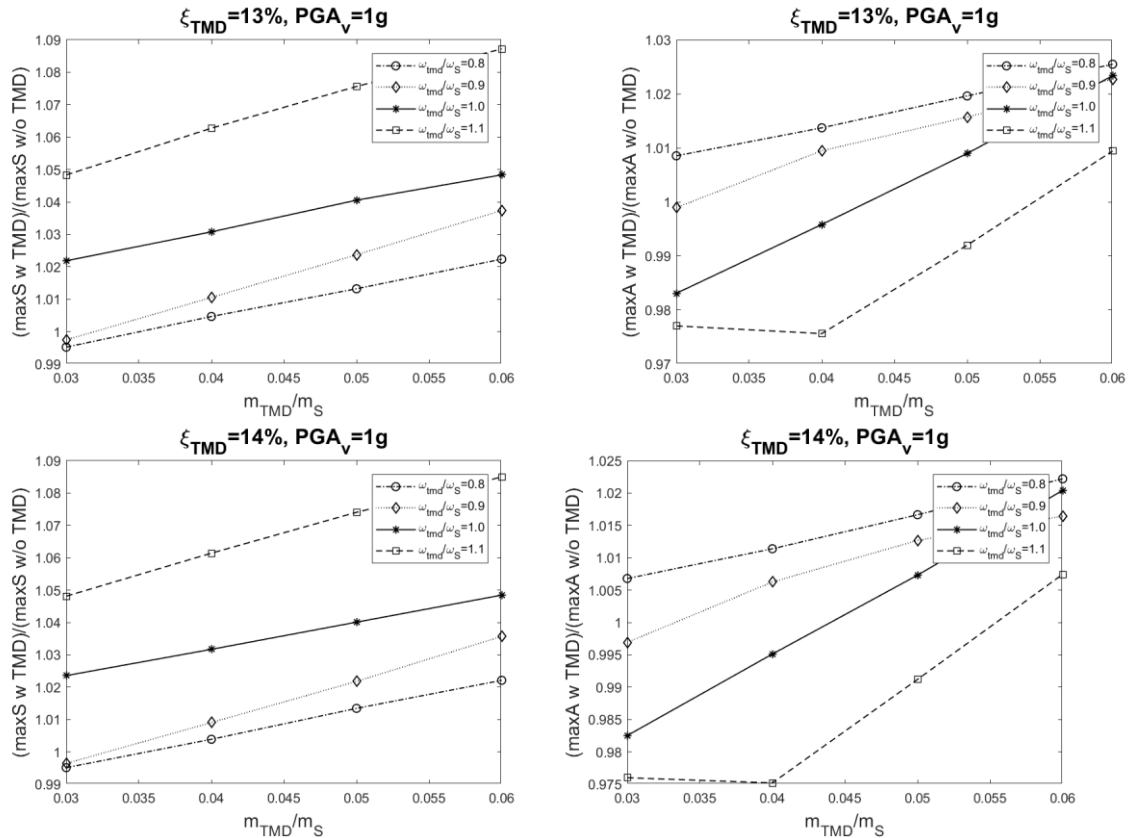

Figure 3: NPP from [2]: parametric study following the Den Hartog [22] tuning equations for different levels of TMD damping (ξ). Horizontal axis: TMD mass over the system mass; vertical axis: ratio between the system response with and w/o TMD; legend: ratio between the system and the TMD circular frequency.

Figure 3 reports the results of a parametric study for the NPP building in [2] in terms of the ratio of the response parameter of interest for the building with and without VBI. The study follows the Den Hartog [22] tuning equations and ranging different levels of TMD design parameters. The selected response parameters are the extreme value of the absolute vertical acceleration (A) of the superstructure, and the extreme value of its vertical relative displacement (S). Figure 4 reports the results of VBI for the NPP for a damping of the superstructure that is 1/10th of that of Figure 3. Finally, Figure 5 reports the results of VBI for the case of a small historical object: a statue.

As it can be appreciated from Figure 3, due to the already sufficiently large amount of damping provided by the VBI devices, (the Seismic isolators are HDRB, so a high level of inherent damping is considered [2]), the introduction of a TMD resulted in a deterioration of the response both in terms of acceleration and displacements. At the increase of the damping in the TMD the response deteriorates even more, and a TMS does not seem to be a proper solution of additional damping for the structure.

However, considering also the extensive use of low damping rubber bearings in existing structures, as the natural rubber bearings, also for nuclear facilities, the benefits of TMD implementation for existing and new structures can be highlighted [23,24]. Thus, Figure 4 for the same NPP building in [2], with a reduced intrinsic damping of the isolation layer (about 1%), highlights the benefits that can be provided by the implementation of a TMD system. This positive effect is mainly provided with respect to the absolute acceleration response.

Finally, Figure 5 depicts the case of a small statue, vertically isolated by metallic springs. For the reasons already expresses, the damping in this case is very low. Due to the low initial value of the damping in the superstructure, that is provided only by material hysteresis in the springs, the introduction of a TMS is highly beneficial for both the absolute acceleration in the vertical direction and the relative displacements, to an extent similar to the one for the NPP with low damping isolation bearing.

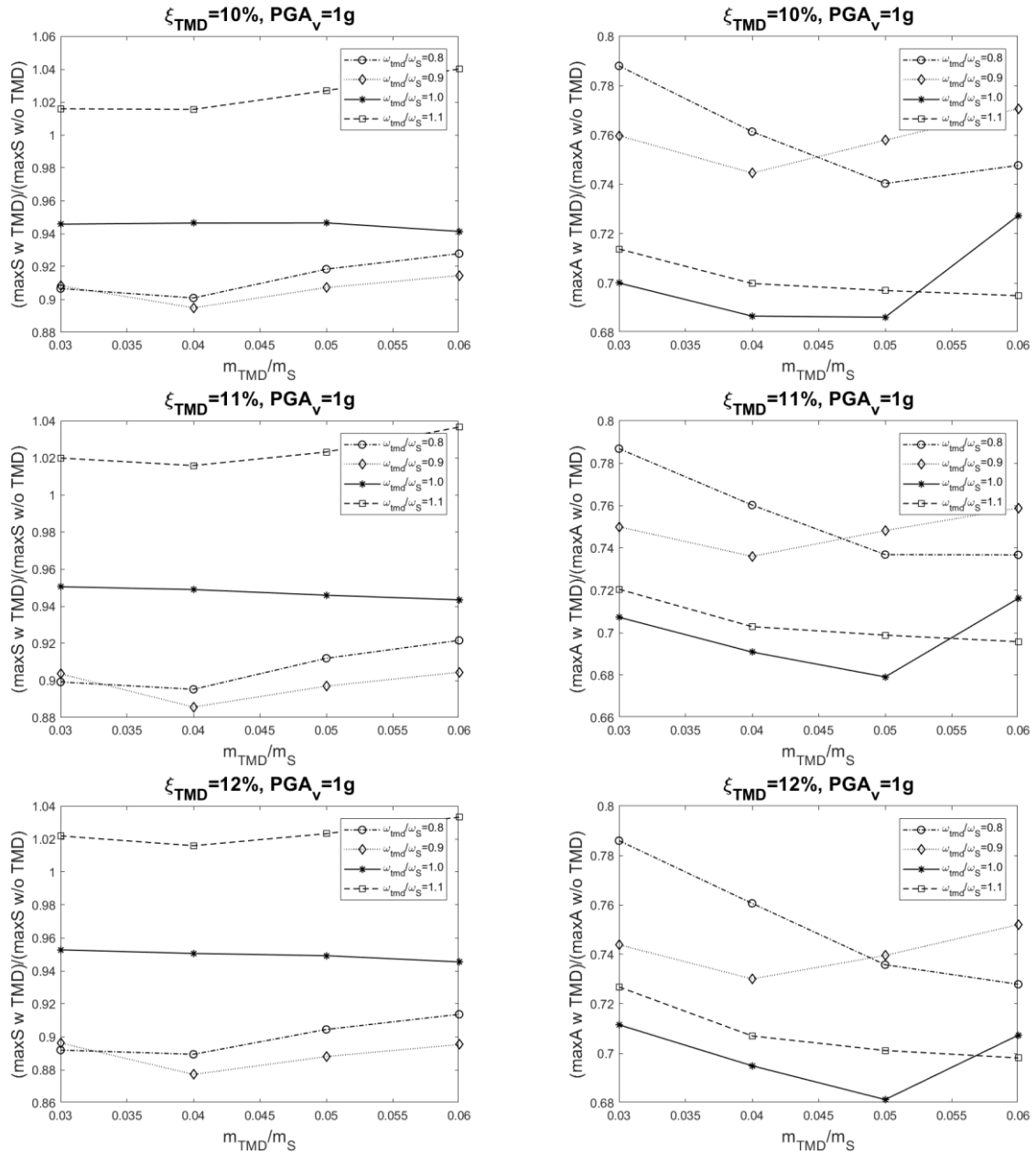

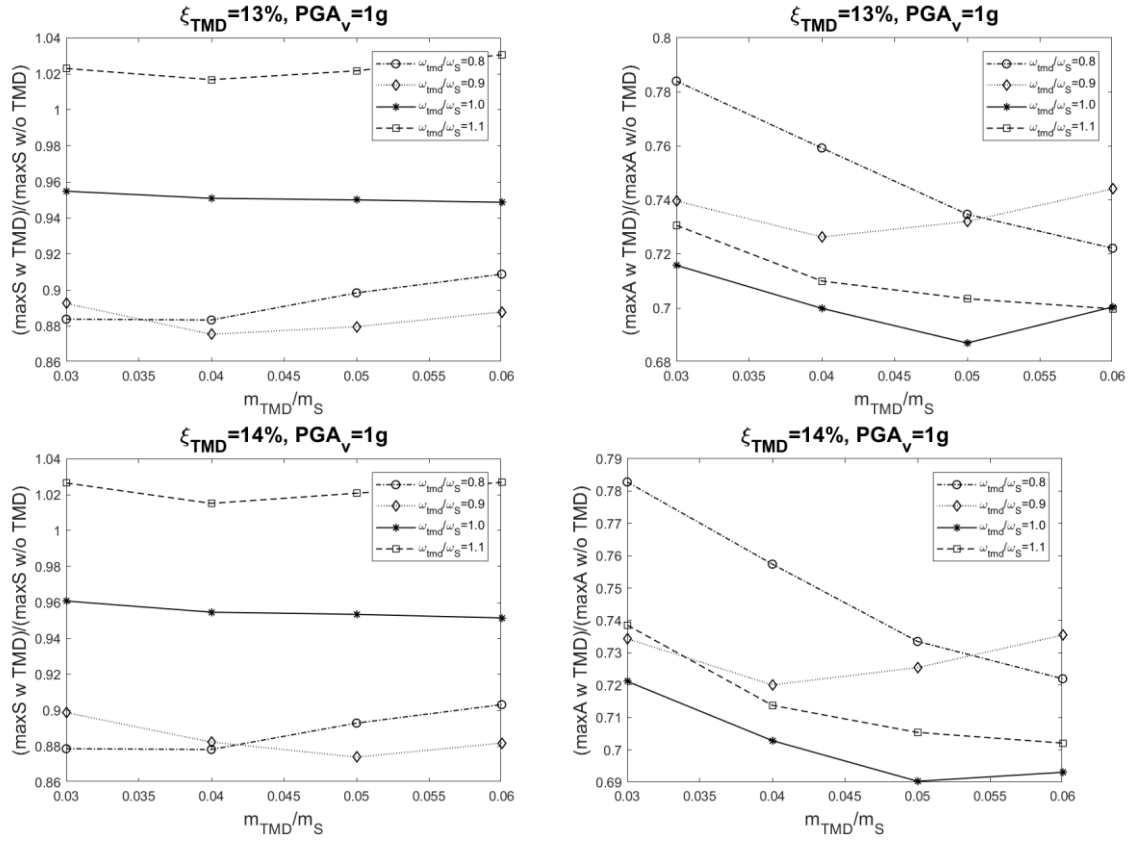
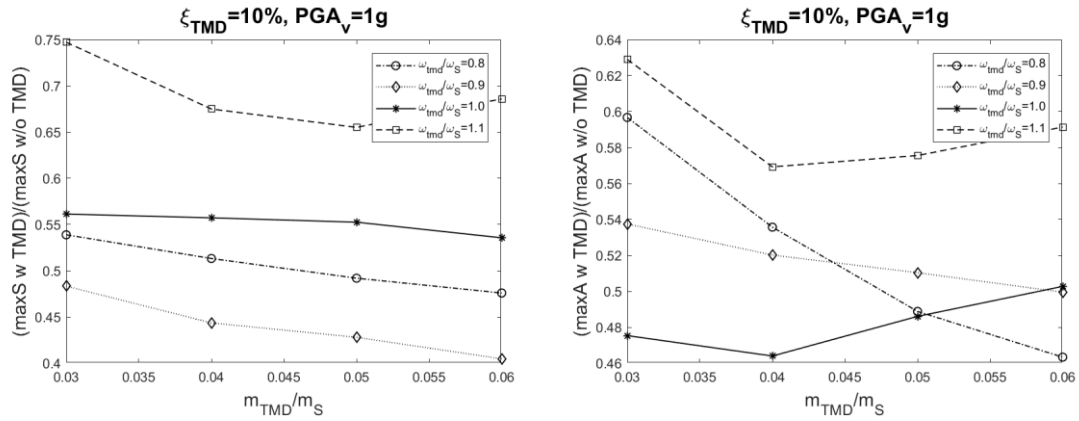

Figure 4: NPP from [2] with reduced damping in the rubber bearings isolation layer: parametric study following the Den Hartog [22] tuning equations for different levels of TMD damping (ξ). Horizontal axis: TMD mass over the system mass; vertical axis: ratio between the system response with and w/o TMD; legend: ratio between the system and the TMD circular frequency.



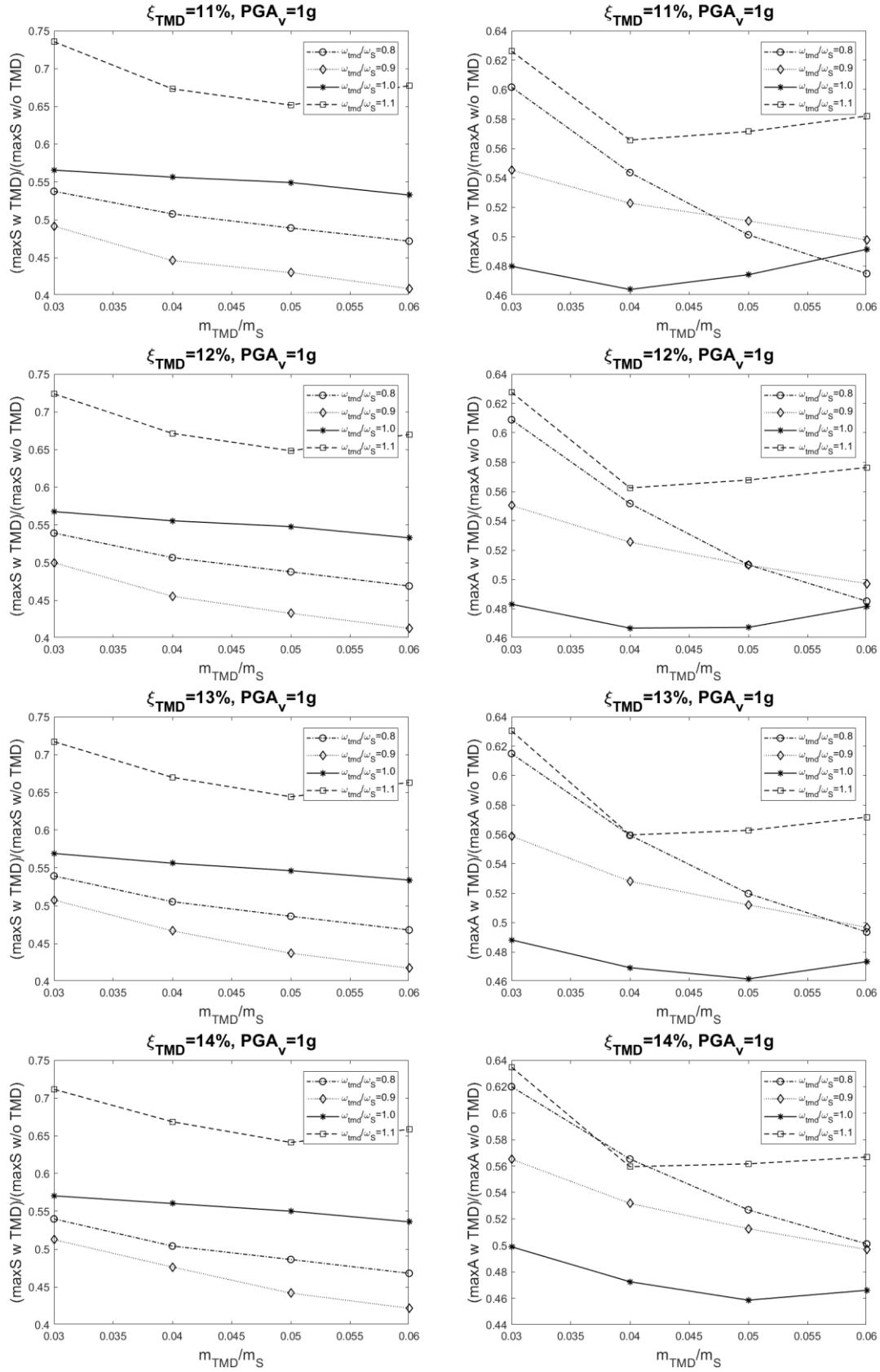

Figure 5: Statue: parametric study following the Den Hartog [22] tuning equations for different levels of TMD damping (ξ). Horizontal axis: TMD mass over the system mass; vertical axis: ratio between the system response with and w/o TMD; legend: ratio between the system and the TMD circular frequency.

5 CONCLUSIONS

- This paper deals with a preliminary study of an innovative solution that consists in the implementation of a TMD in the vertical direction in parallel to traditional base isolated systems to mitigate the vertical response. Therefore, a 3-D base isolation with uncoupled reaction components is achieved.
- To test the proposed procedure with respect to traditional isolated ones, simple case studies are considered, in particular a heavy and lightweight case studies. They are a NPP building and a statue respectively.
- The preliminary results show that the implementation of TMD can be beneficial to reduces the vertical absolute accelerations and the relative vertical displacements of the superstructure. However, the level of the inherent damping in the base isolation bearings drive the effectiveness of the proposed solution. Indeed, it is verified effective only with low damping base isolation devices, as natural rubber bearings or steel helical springs.
- Further research will be focused on the investigation of more complex structural conditions, considering both the vertical and horizontal nonlinear structural response. Furthermore, more general seismic inputs will be considered for a comprehensive earthquake scenario, to evaluate the practicability and the effectiveness of the proposed solution.

ACKNOWLEDGMENTS

The research leading to these results has received funding from the European Research Council under the Grant Agreement n°ERC_IDEalreSCUE_637842 of the project IDEAL RESCUE - Integrated DEsign and control of Sustainable CommUnities during Emergencies.

REFERENCES

- [1] M. Domaneschi, L. Martinelli, C. Cattivelli (2018), “Phenomenological Model of Seismic Isolation Rubber Bearings with Variable Axial Loading”, *Frontiers in Built Environment – Earthquake Engineering*, Vol.4, Article 49.
- [2] F. Perotti, M. Domaneschi, S. De Grandis (2013), “The numerical computation of seismic fragility of base-isolated Nuclear Power Plant buildings”, *Nuclear Engineering and Design*, 262:189–200.
- [3] B. Basu, O. Bursi, F. Casciati, S. Casciati, A. Del Grosso, M. Domaneschi, L. Faravelli, J. Holnicki, H. Irschik, M. Krommer, M. Lepidi, A. Martelli, B. Oztork, F. Pozo, G. Pujol, Z. Rakicevic, J. Rodellar (2014), “An EACS joint perspective. Recent studies in civil structural control across Europe”, *Structural Control & Health Monitoring*, 21(12), 1414–1436.
- [4] Eurocode 8 EC8 (1998), UNI ENV 1998, Design of Structures for Earthquake Resistance.
- [5] Tanaka et al., “Development of earthquake and microtremor isolation floor system utilizing air springs and laminated rubber bearings”, *IHI Engineering Review (English Edition)*, 22(2), pp. 47-52, 1989.

- [6] G.P. Cimellaro, M. Domaneschi, G. Warn (2018), "Three-Dimensional base isolation using vertical negative stiffness devices", *Journal of Earthquake Engineering*. Published online: 10 Aug 2018.
- [7] Fujka T., "Earthquake isolation technology for industrial facilities: research, development and applications in Japan", *Bulletin of the New Zealand Society for Earthquake Engineering*, 18(3): 224-249, 1985.
- [8] Fujita et al. "3-Dimensional earthquake isolation floor with a direction converter of vibration for vertical isolation", *American Society of Mechanical Engineers, Pressure Vessels and Piping Division Publication PVP*, 181, pp. 43-48, 1989.
- [9] Calio I. and Marletta M., "Passive Control of the Seismic Rocking Response of Art Objects", *Engineering Structures Vol: 25, Issue: 8*. 1009-1018, (2003).
- [10] C.A Castiglioni, A. Kanyilmaz, "A new approach for the Seismic Isolation Methods for Ancient Statues Displayed in Base Isolated Museums", *Proc. 15th WCEE*.
- [11] Z. Zhou et al., "Potentiality of Using Vertical and Three-Dimensional Isolation Systems in Nuclear Structures", *Nuclear Engineering and Technology*, pp: 1237-1251, (48), 2016.
- [12] Younin Lee, Yong-Sy Ji, Woojin Han, Snghyun Choi and Sung Gook Cho, "Shaking Table Test of Vertical Isolation Device", *International Journal of Environmental Science and Development*, Vol. 5, No. 1, February 2014.
- [13] J. P. Den Hartog (1985), *Mechanical Vibrations, Civil, Mechanical and Other Engineering Series*, Dover Civil and Mechanical Engineering, Dover books on engineering, Courier Corporation, 1985, ISBN 0486647854, 9780486647852
- [14] Warburton, G. B. (1982), "Optimum Absorber Parameters for Various Combinations of Response and Excitation Parameters", *Earthquake Engineering & Structural Dynamics*, 10(3), 381-401.
- [15] Ioi, T., and Ikeda, K. (1978), "On the Dynamic Vibration Damped Absorber of the Vibration System", *Bulletin of the Japanese Society of Mechanical Engineering*, 21, (151), 64-71.
- [16] Asami T., Nishihara O., Baz A. M., "Analytical Solutions to H_∞ and H_2 Optimization of Dynamic Vibration Absorbers Attached to Damped Linear Systems", *Transactions of the ASME*, Vol. 124, pp284-294, APRIL 2002.
- [17] Nam Hoang, Yozo Fujino, Pennung Warnitchai, Optimal tuned mass damper for seismic applications and practical design formulas, *Engineering Structures* 30 (2008) 707–715.
- [18] Kanai K., "Semi-empirical formula for the seismic characteristics of the ground", *Bulletin of the Earthquake Research Institute, The University of Tokyo*;35:309–25, 1957.
- [19] Tajimi H., "A statistical method of determining the maximum response of a building structure during an earthquake", In: *Proc. 2nd world conf. on earthquake engineering*, vol. II. p. 781–98, 1960.
- [20] Martinelli L., Barbella G., Feriani A., "Modeling of Qiandao Lake submerged floating tunnel subject to multi-support seismic input", *Procedia Engineering*, Volume 4, Pages 311-318, 2010. <https://doi.org/10.1016/j.proeng.2010.08.035>

- [21] Martinelli L., Barbella G., Feriani A., “A numerical procedure for simulating the multi-support seismic response of submerged floating tunnels anchored by cables”, *Engineering Structures*, 33, pp:2850-2860, 2011. doi: 10.1016/j.engstruct.2011.06.009.(ISSN:0141-0296)
- [22] M. Domaneschi, L. Martinelli, E. Po (2015), “Control of Wind Buffeting Vibrations in a Suspension Bridge by TMD: hybridization and robustness issues”, *Computers and Structures*, 155, 3-17.
- [23] A. S. Whittaker, P. Sollogoub, M. K. Kim (2017), *SEISMIC ISOLATION OF NUCLEAR STRUCTURES: PAST, PRESENT AND FUTURE*, Transactions, SMiRT-24 BEXCO, Busan, Korea - August 20-25, 2017.
- [24] P. Sollogoub (2016), *APPLICATION OF BASE-ISOLATION TO NUCLEAR FACILITIES*, SECED, London UK.