

APPARATUS AND METHOD OF MANUFACTURING METALLIC OR INORGANIC FIBERS HAVING A THICKNESS IN THE MICRON RANGE BY MELT SPINNING

Original

APPARATUS AND METHOD OF MANUFACTURING METALLIC OR INORGANIC FIBERS HAVING A THICKNESS IN THE MICRON RANGE BY MELT SPINNING / Spatz, Joachim; Micoulet, Alexandre; Sharifikolouei, Elham. - (2017).

Availability:

This version is available at: 11583/2784335 since: 2020-01-23T10:35:00Z

Publisher:

Published

DOI:

Terms of use:

This article is made available under terms and conditions as specified in the corresponding bibliographic description in the repository

Publisher copyright

(Article begins on next page)



- (51) **International Patent Classification:**
B22D 11/06 (2006.01) D01F 1/00 (2006.01)
- (21) **International Application Number:**
PCT/EP20 16/070963
- (22) **International Filing Date:**
6 September 2016 (06.09.2016)
- (25) **Filing Language:** English
- (26) **Publication Language:** English
- (30) **Priority Data:**
15 184903.1 11 September 2015 (11.09.2015) EP
- (71) **Applicant:** MAX-PLANCK-GESELLSCHAFT ZUR FÖRDERUNG DER WISSENSCHAFTEN E.V. [DE/DE]; Hofgartenstraße 8, 80539 München (DE).
- (72) **Inventors:** SPATZ, Joachim; Knappenberg 21E, 70569 Stuttgart (DE). MICOULET, Alexandre; Vogesenstrasse 93, 68229 Mannheim (DE). SHARIFIKOLOUEI, Elham; Hegelstrasse 51, 70174 Stuttgart (DE).
- (74) **Agent:** MANITZ FINSTERWALD UND PARTNER GBR; Postfach 310220, 80102 München (DE).

- (81) **Designated States** (unless otherwise indicated, for every kind of national protection available): AE, AG, AL, AM, AO, AT, AU, AZ, BA, BB, BG, BH, BN, BR, BW, BY, BZ, CA, CH, CL, CN, CO, CR, CU, CZ, DE, DK, DM, DO, DZ, EC, EE, EG, ES, FI, GB, GD, GE, GH, GM, GT, HN, HR, HU, ID, IL, IN, IR, IS, JP, KE, KG, KN, KP, KR, KZ, LA, LC, LK, LR, LS, LU, LY, MA, MD, ME, MG, MK, MN, MW, MX, MY, MZ, NA, NG, NI, NO, NZ, OM, PA, PE, PG, PH, PL, PT, QA, RO, RS, RU, RW, SA, SC, SD, SE, SG, SK, SL, SM, ST, SV, SY, TH, TJ, TM, TN, TR, TT, TZ, UA, UG, US, UZ, VC, VN, ZA, ZM, ZW.
- (84) **Designated States** (unless otherwise indicated, for every kind of regional protection available): ARIPO (BW, GH, GM, KE, LR, LS, MW, MZ, NA, RW, SD, SL, ST, SZ, TZ, UG, ZM, ZW), Eurasian (AM, AZ, BY, KG, KZ, RU, TJ, TM), European (AL, AT, BE, BG, CH, CY, CZ, DE, DK, EE, ES, FI, FR, GB, GR, HR, HU, IE, IS, IT, LT, LU, LV, MC, MK, MT, NL, NO, PL, PT, RO, RS, SE, SI, SK, SM, TR), OAPI (BF, BJ, CF, CG, CI, CM, GA, GN, GQ, GW, KM, ML, MR, NE, SN, TD, TG).

Published:
— with international search report (Art. 21(3))

(54) **Title:** APPARATUS AND METHOD OF MANUFACTURING METALLIC OR INORGANIC FIBERS HAVING A THICKNESS IN THE MICRON RANGE BY MELT SPINNING

Fig. 1

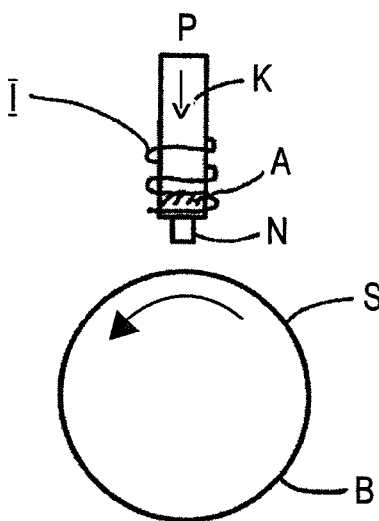

(57) **Abstract:** An apparatus for producing elongate fibers of metal, metallic glasses or inorganic material comprises a rotatable wheel having a planar external circumferential surface, which is flat in a direction parallel to the axis of rotation of the wheel, at least one nozzle having a nozzle opening for directing a molten metal onto the circumferential surface and a collection means for collecting solidified fibers of metal formed on the circumferential surface from the molten metal and separated from the circumferential surface by centrifugal force generated by rotation of the wheel. The nozzle has a rectangular cross-section having a width of the nozzle opening in the circumferential direction of rotation of the wheel and a length transverse to the circumferential surface of the wheel which is greater than the width. An apparatus is provided for controlling a gas pressure applied to the liquid metal which moves the liquid metal through the nozzle opening and delivers it to the circumferential surface of the rotatable wheel. A method of producing elongate fibers is also claimed.

WO 2017/042155 A1

**Apparatus and method of manufacturing metallic or inorganic fibers
having a thickness in the micron range by melt spinning**

5

Melt spinning is a technique used for the rapid cooling of liquids. A wheel may be cooled internally, usually by water or liquid nitrogen, and rotated. A thin stream of liquid is then dripped onto the wheel and cooled, causing rapid solidification. This technique is used to develop materials that require extremely high cooling rates in order to form elongate fibers of materials such as metals, inorganic materials and metallic glasses. The cooling rates achievable by melt-spinning are of the order of $10^4 - 10^7$ kelvin per second (K/s).

The first proposals for melt spinning originated with Robert Pond in a series of related patents from 1958-1961 (US Patent Nos. 2,825,108, 2,910,744, and 2,976,590). In US patents 2,825,198 and 2,910,724 a molten metal is ejected through a nozzle under pressure onto a rotating smooth concave surface of a chill block. By varying the surface speed of the chill block and the ejection conditions it is said to be possible to form metal filaments with a minimum cross sectional dimension of $1\mu\text{m}$ to $4\mu\text{m}$ and lengths from $1\mu\text{m}$ to infinity. In US patent 2,824,198 a single chill block is used, in US patent 2,910,724 a plurality of nozzles direct flows of metal onto one rotating chill block or a plurality of rotating chill blocks and associated nozzles are provided. In US patent 2,910,724 no chill block is provided, instead the molten metal is ejected downwardly through nozzles into a vertically disposed cooled chamber containing solid carbon dioxide on ledges provided at the side wall of the chamber. By varying the cross sectional shape of the nozzles the cross-sectional shape of the filaments produced can be varied.

The current concept of the melt spinner was outlined by Pond and Maddin in 1969. Although, liquid was, at first, quenched on the inner surface of a drum, Liebermann and Graham further developed the process as a continuous casting technique by 1976, this time on the drum's outer surface.

5

The process can continuously produce thin ribbons of material, with sheets several inches in width being commercially available. The dimensions of the bands normally amount to several tens of microns thickness and several centimeters in width and length

10

References to this process can be found in the following publications:

1. R. W. Cahn, Physical Metallurgy, Third edition, Elsevier Science Publishers B.V.,1983.

15

2. Liebermann, H.; Graham, C. (November 1976). "Production of amorphous alloy ribbons and effects of apparatus parameters on ribbon dimensions". IEEE Transactions on Magnetics 12(6): 921—923. doi: 10.1 109/TMAG.1976.1059201.

20

3. Egami, T. (December 1984). "Magnetic amorphous alloys: physics and technological applications". Reports on Progress in Physics 47 (12): 1601 .doi: 10.1 088/0034-4885/47/1 2/002.

25

The melt spinning process has hitherto not been used for the commercial manufacture of micron scale metallic ribbons and fibers on an industrial scale.

In this connection it should be noted that a fiber can be understood as an element of which the length is at least twice its width.

A method of manufacturing microfibers from a metallic melt by depositing the melt on a rotating wheel is described in our as yet unpublished EP application 14 180 273,6 and in the corresponding PCT application PCT/EP2015/068194. There the wheel is provided with a structured surface which modulates the dimensions of the metallic microfibers that are produced.

Metal fiber reinforced composite materials play a central role in a whole series of applications for the improvement of the most diverse properties. Examples of such applications are:

10

- Electrodes for batteries and accumulators,
- Conductive plastics for touch sensitive systems such as displays and artificial hands in the field of robots,
- Anti-electrostatic textiles and plastics,
- Mechanically reinforced textiles, plastics and cement for lightweight and heavy construction,
- Filter materials for use in environments subjected to mechanical and/or chemical stress
- Catalysis

20

An important aspect for the improvement of fiber based material functions is a large surface area to weight ratio of the metal fibers and the ability to manufacture and process them in an industrially relevant process. This signifies:

25

- low widths and adjustable lengths of the metal fibers,
- control of the fiber adhesion for the further processing of the fibers,
- applicable to different materials
- economic manufacturing method and low process costs with a high material yield per unit time,

30

Nowadays, the industrially relevant manufacture of functional materials based on metal fibers is restricted to fiber thicknesses of $> 50\mu\text{m}$. Academic processes exist based on lithographic techniques, glass based template methods and mechanical extrusion processes which enable metallic fibers of $< 50\mu\text{m}$ to be achieved. These methods cannot however be utilized industrially because they are restricted to a few materials and in some cases are not repeatable.

The method and apparatus described in our EP application 14 180 273,6 and in the corresponding PCT application PCT/EP2015/068194 permit the production of micron sized fibers on an industrial scale. However, the need to provide the rotating wheel with a relatively fine and highly precise surface design or topography is a substantial complication and a substantial cost factor in an industrial process.

Further prior art can be found in the following documents: EP 0 055 827 A 1, the publication by S.W. Kim et al. titled "Manufacture and Industrial application of Fe-based Metallic Glasses", published in the Materials Science Forum, in volume 706-709, 2012 on pages 1324 to 1330, the publication by J.K. Sung et al. titled "Theoretical expectations of strip thickness in planar flow casting process", published in Materials Science and Engineering, volumes A 181-A182, 1994 on pages 1237-1242, and the publication by Jech Robert et al. titled: "Rapid Solidification via melt spinning: Equipment and techniques", published in Journal of Metals, volume 36, no. 4 on December 20, 2013 on pages 41-45.

The object of the present invention is to provide an apparatus and a method by which metallic and more generally inorganic microfibers can be generated on an external surface of a rotating wheel, with the microfibers having a homogenous distribution in the thickness of the fibers and a controllable width having a median value in the range from 200nm to $50\mu\text{m}$ as well as a length of 100mm to centimeters or longer by depositing the melt onto a rapidly rotating metal or

ceramic wheel having a smooth planar surface. The fibers should preferably have a thickness and width of less than one micron and a length of 0.5mm to 5mm or larger.

5 In order to satisfy this object there is provided apparatus for producing elongate fibers of metal, of metallic glasses or of inorganic material, the apparatus comprising a rotatable wheel having a planar external circumferential surface, which is flat in a direction parallel to the axis of rotation of the wheel, at least one nozzle having a nozzle opening for directing a molten material onto the
10 circumferential surface, with the nozzle having a rectangular cross section and a width of a slit of the nozzle opening in the circumferential direction of the wheel being selected to lie in the range from 10 to 500 μm and a collection means for collecting solidified fibers of material formed on the circumferential surface from the molten material and separated from the circumferential surface by centrifugal
15 force generated by rotation of the wheel, wherein the apparatus comprises a further apparatus that is configured to control a gas pressure applied to the molten material which moves the molten material through the nozzle opening and delivers it to the circumferential surface of the rotatable wheel and wherein the further apparatus is further configured to regulate the mass flow of molten material down
20 to a level at which microfibers of the material are formed on the rotatable wheel by controlling and keeping the mass flow per unit area of the wheel surface of the molten material which is deposited per unit of area onto the circumferential surface of the rotatable wheel in the range from 0.01 to 100g/ m²*sec for a surface speed of rotation of the wheel in the range from 10 to 100m/sec.

25

The nozzle conveniently has a rectangular cross-section having a width of the nozzle opening in the circumferential direction of rotation of the wheel and a length transverse to the circumferential surface of the wheel which is greater than the width, however this is not essential and the nozzle can in principle be

30 manufactured with the most diverse cross-sectional shapes provided the

dimensions and geometry of the nozzle opening permit the flow of molten metal through the opening to be regulated down to a level at which the desired microfibers are produced. As a further example the nozzle could have a crescent shaped opening, or could comprise a row of interconnected generally circular or elliptical or rectangular openings or a row of discrete circular or elliptical or rectangular openings, the row in each case being disposed parallel to the axis of rotation of the wheel or at an angle to the axis of rotation of the wheel. References to the width of the nozzle slit can then be understood as the width or the average width of the circular, elliptical or rectangular openings in a direction parallel to the direction of surface rotation of the wheel.

It should be noted in this connection that the prior art cited in the introduction to the specification does not show that the currently described nozzle widths can produce the desired fibers and that the desired fibers can be produced at the wheel speed ranges respectively at ranges of the surface speed of rotations of the wheel described herein.

The present invention also relates to a method for producing elongate microfibers of metal, or metallic glasses or of inorganic material having a median width of $50\mu\text{m}$ or less, a thickness of $5\mu\text{m}$ or less and a length at least ten times greater than said width, the method comprising the steps of directing a molten material through a nozzle onto a planar external circumferential surface of a rotating wheel, with the nozzle having a nozzle opening for directing a molten material onto the circumferential surface, with the nozzle having a rectangular cross section and a width of a slit of the nozzle opening in the circumferential direction of the wheel being selected to lie in the range from 10 to 500 μm , by applying a gas pressure to the molten material to move it through the nozzle opening and deliver it to the circumferential surface of the rotatable wheel, and collecting solidified fibers formed on the circumferential surface from the molten material and separated from the circumferential surface by centrifugal force generated by rotation of the wheel,

the method further comprising the steps of selecting the dimensions and geometry of the nozzle in combination with the gas pressure (ΔP) to regulate the mass flow of molten material (M_{fa}) which is deposited per unit of area onto the circumferential surface of the rotatable wheel to a value in the range from 0.1 to 5 100g/(m²*sec), especially between 0.5 and 50g/ (m²*sec), particularly between 0.7 and 30g/ (m²*sec) and ideally around 1g/ (m²*sec) for a surface speed of rotation of the wheel in the range from 10 to 100m/sec to form microfibers of the material on the rotatable wheel by reducing the flow of molten material onto the circumferential surface of the wheel in a material dependent manner to a level at 10 which it is concentrated by the forces that are acting to produce the desired elongate fibers of the material.

The flow of material is reduced to a level at which the elongate fibers have a width of 200μm to < 1μm, preferably of 150μm to < 1μm and especially of < 50μm to < 15 1μm. This means that the volume of liquid material V_m which is deposited per unit of area onto the circumferential surface of the rotatable wheel is controlled. The metal strands or fibers thereby produced typically have a thickness of less than or equal to 5μm to < 1μm.

20 The length of the fibers is controlled by including grooves or elevations of 5mm to 1mm on top of the wheel surface onto which the melt is deposited. The grooves or elevations run parallel to the rotation axis with distances between the grooves and elevations which correspond to the length of the fibers. Practically, these grooves and elevations can be prepared by mechanical machining.

25

The underlying concept of the invention can be seen from the following calculations based on experimental results:

The quantity of the metallic melt deposited per second (Mf) lies between 0.01 and 10 g/sec; especially between 0.1 and 5g/sec, particularly between 0.2 and 3g/sec and ideally around 0.25g/sec.

- 5 The speed of rotation of the wheel surface (U) typically lies between 10 and 100 m/sec; especially between 30 and 80m/sec, ideally at 60 m/sec.

The mass flow per unit area = Mfa can be calculated as follows, when the speed of rotation of the surface of the wheel is U(m/sec) and the length of the nozzle

- 10 opening is Ld:

$$Mf = 0.01 \text{ g/sec}; U=10 \text{ m/sec}, Ld=1 \text{ cm} : Mfa = Mf / (U * Ld * \text{sec}) = 0.1 \text{ g} / (\text{m}^2 * \text{sec})$$

$$Mf = 10 \text{ g/sec}; U=100 \text{ m/sec}, Ld=1 \text{ cm}: Mfa = Mf / (U * Ld * \text{sec}) = 10 \text{ g} / (\text{m}^2 * \text{sec})$$

$$Mf = 10 \text{ g/sec}; U=10 \text{ m/sec}, Ld=1 \text{ cm} : Mfa = Mf / (U * Ld * \text{sec}) = 100 \text{ g} / (\text{m}^2 * \text{sec})$$

- 15 $Mf = 0.01 \text{ g/sec}; U=100 \text{ m/sec}, Ld=1 \text{ cm} : Mfa = Mf / (U * Ld * \text{sec}) = 0.01 \text{ g} / (\text{m}^2 * \text{sec})$

Thus Mfa ranges between 0.01 and 100 g / (m² * sec); ideally at 0.42 g/(m² * sec) for U=60m/sec und Mf=0,25g/sec. It will be understood that the Mfa values quoted

- 20 herein apply per linear centimeter of the nozzle orifice length L.

These Mfa limits can be transformed as follows for the case of steel with a density G of circa 8 g/cm³ to the expected layer thicknesses (d) of the melt on the wheel before separating into fibers:

- 25

$$Mfa = 0.01 \text{ g}/(\text{m}^2 * \text{sec}) : d= (Mfa/ G)^* (\text{m}^2 * \text{sec} / U * Ld * \text{sec}) = 1/8 * 10^{-2} \text{ mm}$$

$$Mfa = 100 \text{ g}/(\text{m}^2 * \text{sec}) : d= 1/8 \text{ mm}$$

Ideally with

- 30 $Mfa=0.42 \text{ g}/(\text{m}^2 * \text{sec}) : d= 0.0875 \text{ mm}.$

It is particularly surprising that it is possible, by providing an apparatus and a method with the above features, to generate metal strands and fibers with dimensions which can be controlled within relatively tight limits using a rotatable
5 wheel with a smooth, polished planar, non-structured surface having a certain surface roughness. The copper wheels used for the experiments detailed below were polished prior to each experiment. It is expected that there is some correlation between the surface roughness and the width of the fibers.

10 A controller is preferably provided for keeping the speed of rotation of the wheel constant so that the surface speed of the wheel lies in the range from 40 to 60m/s with a wheel of 20 cm or larger diameter of the external circumferential surface. The production of fiber material is a combination of the material flow from the nozzle and the speed of rotation of the rotatable wheel. If one succeeds in
15 drastically reducing the metal flow from the nozzle then it is also possible to operate with lower speeds of rotation, i.e. surface speeds of the wheel. Accordingly a speed of rotation of 10Hz with a wheel of 200mm diameter is also entirely possible providing the amount of molten material issuing from the nozzle is correspondingly reduced. It has proved possible to generate microfibers at speeds
20 of rotation of 60Hz with a wheel of 200mm diameter. A surface speed of 100m/s of a copper wheel is close to the mechanical limit for a copper wheel of 200mm diameter. However, higher speeds are possible if the material of the wheel is changed, for example speeds of up to 200m/s for a stainless steel wheel of 200mm diameter.

25

Controlling the surface speed of the wheel in this manner makes it possible to ensure the flow of metal from a rectangular orifice of fixed width, or from another suitable orifice can be reduced to a level at which metal fiber of the desired size can be produced.

30

Although a diameter of the wheel of 20cm to 35cm is preferred this is not critical and wheel diameters in the range from 1 to 100cm can be used. A larger diameter of the circumferential surface of the rotating wheel increases the surface speed of the wheel if the speed of rotation is kept constant. Thus a larger diameter of the wheel results in a smaller width of the metal fibers at constant speed of rotation. The width of the opening of the slit of the nozzle in the circumferential direction of the wheel is preferably selected (for a rectangular nozzle opening or a crescent shaped opening) to lie in the range from 20 to 500 μm and especially in the range from 20 to 100 μm . These are currently the practical size ranges for the width of the nozzle opening. It is however possible that higher peripheral speeds of the wheel will enable greater widths or sizes of the nozzle opening for the production of microfibers. The maximum length of the slit corresponds to the width of the external circumferential surface of the wheel in a direction parallel to the axis of rotation thereof, i.e. is the same as or less than the width of the external circumferential surface of the wheel, e.g. several centimeter shorter than the width of the external circumferential surface of the wheel. In the examples given, the width of the slit was ca. 1cm and the width of the wheel ca. 4cm.

For the sake of completeness it should be noted that Liebermann who produced ribbons of 10 to 40 μm thickness used a nozzle with a circular orifice.

The temperature of the melt is preferably kept 100 to 400 $^{\circ}\text{C}$ greater than the melting point of the metal. As the viscosity of the melt reduces with increasing temperature of the melt the reduction in viscosity with increasing temperature must be borne in mind when selecting the operating parameters for a particular metal in order to ensure the rate of delivery of molten metal to the rotatable wheel is kept sufficiently low for fibers of the desired dimensions to be achieved. The viscosity of the melt also depends on the material of the melt.

In addition to the foregoing the pressure exerted on the melt upstream of the nozzle is controlled to be higher than the pressure prevailing in the melt spinning chamber by an amount in the range from 50 to 5000 mbar. Although the aim is to reduce the amount of melt delivered to the rotatable wheel so that the desired sizes of microfibers arise, it nevertheless proves possible, with a nozzle length of 5 10mm, to process one gram of metal per second to microfibers, so that the process is industrially relevant.

The rotatable wheel is preferably temperature controlled, e.g. to a temperature in 10 the range of -100 °C to +400°C.

The wheel is usually made of a metal, for example copper or stainless steel, or of a metal alloy or of a ceramic material or is a wheel of a base material having a layer or tire made of a metal or of a metal alloy or of a ceramic material or of 15 graphite or a vapor deposited carbon, for example a copper wheel having a layer of graphite.

The wheel is preferably mounted to rotate within a chamber having an atmosphere, the atmosphere being at least one of air, an inert gas, nitrogen, or 20 helium.

Moreover, the wheel is preferably mounted to rotate within a chamber having an atmosphere at a pressure corresponding to the ambient atmospheric pressure, or to a lower pressure than ambient pressure. 25

Generally speaking the thickness and width of the microfibers can be controlled by dispensing a metallic melt from a crucible standing under a pressure P through a rectangular slot of area A onto a rapidly rotating planar wheel. In this connection the following process parameters have been found to be the determining factors: 30

Mfa - the mass of liquid metal dispensed per unit of area per second onto the surface of the rotating wheel, should be controlled and kept very low, typically below $10 \text{ g}/(\text{m}^2 \cdot \text{sec})$.

5 In detail it has been found that the width of the fibers can be set in that a lower value of V_m results in a lower width of the metal fibers

Mfa can be set by adjusting the following process parameters:

U - the surface speed of rotating wheel B on which the metallic melt is deposited.

10 In the experiments U was varied between 18 and 60m/sec and it was found that higher speeds resulted in a lower width of the fibers. Speeds between 10 and 100m/sec are readily conceivable.

A - the aperture area of the slit of the rectangular slit of the crucible through which the metallic melt is distributed onto the surface of the wheel. Reducing the width of the slit in the circumferential direction of the wheel results in a reduced value of V_m . The width W of the slit can be selected to lie at a value between 10 and $500 \mu\text{m}$.

20 T - the temperature of the melt. As noted above the viscosity of the melt sinks with increasing temperature. A lower viscosity results in a higher V_m under constant conditions. Hence controlling T allows V_m to be reduced. It must be borne in mind that T has to be selected in dependence on the metal that is being used.

Temperatures in the range from 100 to 400°C above the melting point of the metal being used have been found to be useful.

25

P - the excess pressure which is used to expel the melt through the nozzle opening of the crucible. A higher value of ΔP , i.e. of the pressure difference between the pressure acting on the melt in the crucible and the pressure prevailing within the processing chamber, results in a higher V_m , however it must be borne in

30 mind that a narrow value of the width of the nozzle may require higher values of

pressure ΔP to partly compensate for the reduction in V_m due to the narrower width. In the experiments conducted pressures ΔP between 50 and 2000 mbar were found to be useful.

- 5 It is not easy to understand or predict why the metallic melt is split up into microfibers if M_{fa} is appropriately selected. A possible academic explanation is as follows:

Dewetting of thin liquid films on solid supports may appear by two different
10 mechanisms:

(i) heterogeneous hole nucleation due to defects in the liquid film imposed by surface defects such as surface roughness which act as nucleation sites for the liquid material, and

- 15 (ii) spontaneous rupture of the liquid film under the influence of long range molecular forces, known as spinodal dewetting.

These forces can destabilize a thin film by causing surface fluctuations to grow exponentially. Rupture takes place on a length scale corresponding to the wavelength of the surface undulation whose amplitude increases most rapidly till it
20 reaches the thickness of the film, also called critical film thickness.

In the case of an ideally flat surface no heterogeneous hole nucleations due to defects is expected.

- 25 Therefore, for dewetting to occur, a reduced film thickness less than the critical film thickness of the liquid film on a flat substrate needs to be provided. In the case of a non-moving substrate, surface forces which appear on the air-liquid and liquid-solid interface pull undulations in the thin film which eventually cause dewetting, i.e. holes. Such dewetting occurs within microseconds.

For moving solid substrates such as in the case of a rotating wheel which gets coated by ejection of a metal liquid film through the opening of a crucible the situation is drastically different.

- 5 The ejection direction is perpendicular to the movement of the surface of a rotating wheel. Upon contact of the liquid film with the moving solid support two additional forces pull on the air-liquid and liquid-solid interface: a tangential traction forces which pulls the liquid film with the moving solid support and a centrifugal force which pulls vertically away from the solid interface. These two forces may be
- 10 enormous since the circular movement of the solid support is in the range of 60 m/sec or more. The traction forces cause the film to spread thinly and eventually to dewet if the film thickness is less than the critical film thickness of the material. The centrifugal force pulls on the appearing surface film undulations and promotes the dewetting structure even more. Since the traction force and the centrifugal
- 15 force are one dimensional forces which respectively act tangentially and vertically to the liquid film surface, the undulations appear in stripe pattern in the direction of the traction force. This process may take a time in the range of microseconds. The cooling rate of melt spinning is in the range of 10^4 — 10 microseconds per 100 degree centigrade — rather 1-10 microseconds - considering the little material
- 20 which needs to be cooled in case of microfiber fabrication. Therefore, cooling rate and spinodal dewetting cover similar time ranges! If the temperature of the liquid film drops below its melting temperature slower than the dewetting time, solidified microfibers are spun-off the wheel. Therefore, macroscopic long fibers with microscopic width are fabricated where the width of the fiber depend on the
- 25 amount of liquid material which is cast onto the rotating wheel area per unit time. A defect on the surface of the rotating wheel, such as topographic domains or surface roughness act as a nucleation site for the liquid film in addition to the spinodal dewetting. Regular domains along the surface of the wheel and perpendicular to the rotation axis may support to form a more homogeneous
- 30 distribution of the fiber width and length. In the case of conical shaped domains

centrifugal forces will force the liquid film to accumulate at the tip of the cones. This will impact the shape and uniformity of such fabricated microfibers.

References:

- 5 Spinodal Dewetting in Liquid Crystal and Liquid Metal Films, Stephan Herminghaus, Karin Jacobs, Klaus Mecke, Joerg Bischof, Andreas Fery, Mohammed Ibn-Elhaj, Stefan Schlagowski: Science 1998, 282, 916

- Dewetting of an Evaporating Thin Liquid Film: Heterogeneous Nucleation and
10 Surface Instability, Uwe Thiele, Michael Mertig, and Wolfgang Pomp: Physical Review Letters 1997, 80, 2869.

The invention will now be described in further detail and by way of example only with reference to the accompanying drawings and various examples of the method
15 of the invention. In the drawings there are shown:

Fig. 1 a schematic illustration of the basic melt spinning process,

Fig. 2 a front view of the apparatus used for melt spinning equipped with
20 the rotatable wheel of the present invention,

Fig. 3 a detail view of the apparatus of Fig.2 as seen in a front view with the housing removed,

25 Fig. 4 a top view of the discharge orifice of the crucible with an explanatory sketch,

Fig. 5 a photograph of a melt spun ribbon of an Fe40Ni40B20 alloy spun on a copper wheel of 200mm diameter rotating at 30Hz, comparative
30 example 1.,

- Fig. 6 a table showing important parameters for sixteen experiments comprising one comparative example and fifteen inventive examples,
- 5 Fig. 7 one photograph (top left) and two SEM images top and bottom right) for fibers produced in the experiment of Example 2 with the scale bars in the photograph indicating a length of 10mm and the scale bars for the top and bottom SEM images indicating lengths of 200 μm and 20 μm respectively,
- 10 Fig. 8 one photograph (top left) and two SEM images top and bottom right) for fibers produced in the experiment of Example 3 with the scale bars in the photograph indicating a length of 10mm and the scale bars for the top and bottom SEM images indicating lengths of 200 μm and 20 μm respectively,
- 15 Fig. 9 one photograph (top left) and two SEM images top and bottom right) for fibers produced in the experiment of Example 4 with the scale bars in the photograph indicating a length of 10mm and the scale bars for the top and bottom SEM images indicating lengths of 200 μm and 20 μm respectively,
- 20 Fig. 10 one photograph (top left) and two SEM images top and bottom right) for fibers produced in the experiment of Example 5 with the scale bars in the photograph indicating a length of 10mm and the scale bars for the top and bottom SEM images indicating lengths of 200 μm and 20 μm respectively,
- 25 Fig. 11 one photograph (top left) and two SEM images top and bottom right) for fibers produced in the experiment of Example 6 with the scale
- 30

bars in the photograph indicating a length of 10mm and the scale bars for the top and bottom SEM images indicating lengths of 200 μ m and 20 μ m respectively,

5 Fig. 12 one photograph (top left) and two SEM images top and bottom right) for fibers produced in the experiment of Example 7 with the scale bars in the photograph indicating a length of 10mm and the scale bars for the top and bottom SEM images indicating lengths of 200 μ m and 20 μ m respectively,

10

Fig. 13 two SEM images for fibers produced in the experiment of Example 8, with the images being taken at different positions of the sample and with the scale bars in the left and right hand images indicating lengths of 30 μ m and 20 μ m respectively.

15

Turning now to the schematic drawing of the melt spinning process shown in Fig. 1 it can be seen that the metal A to be spun is heated in a crucible K by an electrical heating device ϵ . A gas pressure P presses the molten metal through the nozzle N of the crucible K onto the rotating wheel B. The wheel B has a planar external circumferential surface (S), which is flat in a direction parallel to the axis of rotation of the wheel (B). I.e. the circumferential surface S of the wheel corresponds to a surface of revolution obtained by rotating a straight line in a circle about an axis of rotation parallel to the straight line. As shown in Fig. 4 the nozzle N of the crucible K, which is typically made of boron nitride, has a nozzle opening O of rectangular shape. From the schematic diagram of Fig. 4 it can be seen that the length direction L of the nozzle opening is oriented transversely to the circumferential direction C of the circumferential surface S of the wheel B and extends over a substantial part of the axial width of the circumferential surface of the wheel, and in a practical example over at least most of the axial width of the wheel, so that the nozzle opening distributes molten metal across the axial width of the surface of the

20

25

30

wheel B. The width W of the slot can be chosen within relatively wide limits, e.g. $500\mu\text{m}$ and $10\mu\text{m}$ to control the rate of flow of the molten metal from the nozzle N onto the structured surface S of the wheel B. When the width W is relatively large a relatively higher flow rate for the molten metal onto the structured surface of the wheel B is obtained and, for a given speed of the wheel, the strands produced are of relatively large cross-section. As the width W is reduced, which is achieved by substituting one crucible K for another one with the desired nozzle width W , the flow rate of the molten metal onto the structured circumferential surface S of the wheel B is reduced and, for the same speed of rotation of the wheel, the strands produced are relatively smaller in cross-section.

The pressure P applied to the molten metal can also be used to change the flow rate. Clearly a relatively large pressure leads to a higher flow rate than a relatively lower pressure. A minimum pressure P is always required in order to force the molten metal through the nozzle N , as gravity alone is not normally sufficient to ensure adequate flow, particularly with a relatively small width W of the nozzle opening. In fact this is advantageous because otherwise some form of valve would be necessary and a valve for regulating the flow of molten metal is technically challenging. It should be noted that the pressure difference ΔP between the pressure applied to the melt and the pressure prevailing in the chamber 12 is dependent on the metal used and on the width of the nozzle opening in the circumferential direction. It is also dependent on the length of the nozzle opening in a direction parallel to the axis of rotation of the wheel. The length of the nozzle opening can be varied within wide limits. For laboratory experiments values of 10 to 12mm have been found useful. In production much greater lengths could be selected in dependence on the axial width of the circumferential surface of the wheel.

The actual apparatus used is shown in Figs. 2 and 3. Apart from the design of the wheel B the apparatus shown in Figs 2 and 3 is basically a commercially available

- melt spinner obtainable from the company Edmund Buehler GmbH, Hechingen, Germany. It consists of a metallic chamber 10 having a cylindrical portion 12 and a tangentially extending collection tube 14 with a closable port 16 at the end remote from the cylindrical portion 12. The crucible K with the electrical heating system I and the gas pressure supply P are mounted within a short cylindrical extension 18 of the chamber 10 above the cylindrical portion 12 and are provided with the necessary supply lines for a pressurized gas such as argon, for electrical power and control of the gas flow valve determining the pressure P, for the power of the heating system I and for the monitoring of parameters such as gas pressure and temperature of the melt. The wheel B is mounted on the inside of and concentric to the cylindrical portion 12 and is supported by bearings (not shown) on an axle 20 driven by an electric motor 22 flanged to the rear of the cylindrical portion 12 (see Fig. 3). The front side 24 of the cylindrical portion, i.e. the side 26 opposite the drive motor 22 is made of glass so that the spinning process can be observed and filmed by a high speed camera. The chamber 10 can be evacuated by a vacuum pump via an evacuation stub 28 and can be supplied with a flow of an inert or reactive gas via a further feed stub 30. Thus a desired atmosphere at a desired temperature and pressure can be provided within the chamber 10.
- 20 The cover for closing the port 16 can be a hinged or removable glass cover permitting the material collected in the cylindrical extension 18 to be observed, removed and filmed as required. In all experiments the copper wheel was not cooled.
- 25 The following experiments were conducted:

Example 1 - Comparative example

In the first experiment melt spun ribbons were generated on a standard copper
5 wheel B with a diameter of 200 mm and a smooth circumferential surface 32
(indicated at S in Fig.1 and seen in plan view in Fig. 3) having the shape of a right
cylinder. A melt of Fe₄₀Ni₄₀B₂₀ is formed by the heating system I within the
boron nitride crucible K. The crucible K has a slit orifice with nominal dimensions,
length L = 10 mm and width W = 400 μm. Once the metal has melted gas pressure
10 is applied to the molten gas by the pressure source P to expel the molten metal
through the orifice and onto the copper wheel B. The copper wheel B was rotated
by the drive motor at a surface speed of 18.8 m/s. The mass of the metal sample
was ca. 10 g. As shown in Figure 5, a single continuous ribbon was generated,
which had a length of > 1 m, a typical width of 9.3 +1- 0.1 mm, and a typical
15 thickness of 42 +1 -2 microns. Fig.5 shows that the ribbons manufactured in this
way are of good quality. However they are of much larger width and thickness than
the dimensions aimed at in the present invention and thus the example is
classified as a failed example..

20 In the following examples will be given of fibers produced by melt spinning using a
smooth flat wheel and an Fe₄₀Ni₄₀B₂₀ metallic glass (examples 3 to 7 and 9 to
14), for stainless steel (V2A example 8) as well as for Zn and Al (examples 15 and
16). Where reference is made to the median width this value is obtained in
accordance with the usual definition. In all cases the thickness of the majority of
25 the fibers was less than 5 μm. As yet no attempts have been made to more
accurately determine the thicknesses

Example 2 - Inventive example

Material: Fe ₄₀ Ni ₄₀ B ₂₀	Experiment MS048
Nominal length of nozzle opening	10 mm
Nominal width of nozzle opening	400 μ m
Temp of wheel	RT (~23°C)
Gas in chamber	Argon
Pressure in chamber 12	400 mbar
Temp. of gas in chamber 12	RT
Ejection temperature	1400°C
Ejection pressure	600 mbar
Surface speed of wheel	59.4m/s
Diameter of wheel	200 mm
Distance between nozzle and wheel	0.3 mm
Width of the resultant fibers	Max 1296 μ m , min 6.3 μ m
Thickness of the resultant fibers	< 5 μ m

Example 3 - Inventive example

Material: FE40Ni40B20	Experiment MS047
Nominal length of nozzle opening	10 mm
Nominal width of nozzle opening	200 μ m
Temp of wheel	RT (~23°C)
Gas in chamber	Argon
Pressure in chamber 12	400 mbar
Temp. of gas in chamber 12	RT
Ejection temperature	1400°C
Ejection pressure	600 mbar
Surface speed of wheel	59.4m/s
Diameter of wheel	200 mm
Distance between nozzle and wheel	0.3 mm
Width of the resultant fibers	Max 335 μ m , min 3 μ m
Thickness of the resultant fibers	< 5 μ m

Example 4 - Inventive example

Material: Fe ₄₀ Ni ₄₀ B ₀	Experiment MS045
Nominal length of nozzle opening	10 mm
Nominal width of nozzle opening	100 μm
Temp of wheel	RT (~23°C)
Gas in chamber	Argon
Pressure in chamber 12	400 mbar
Temp. of gas in chamber 12	RT
Ejection temperature	1400°C
Ejection pressure	800 mbar
Surface speed of wheel	59.4m/s
Diameter of wheel	200 mm
Distance between nozzle and wheel	0.3 mm
Width of the resultant fibers	Max 2 16.1 μm , ηηηη 3.1 μm
Thickness of the resultant fibers	< 5 μm

Example 5 - Inventive example

Material: Fe40Ni40B20	Experiment MS051
Nominal length of nozzle opening	10 mm
Nominal width of nozzle opening	75 μ m
Temp of wheel	RT (~23°C)
Gas in chamber	Argon
Pressure in chamber 12	400 mbar
Temp. of gas in chamber 12	RT
Ejection temperature	1400°C
Ejection pressure	1000 mbar
Surface speed of wheel	59.4m/s
Diameter of wheel	200 mm
Distance between nozzle and wheel	0.3 mm
Width of the resultant fibers	Max 94 μ m , min 2.3 μ m
Thickness of the resultant fibers	< 5 μ m

Example 6 - Inventive example

Material: Fe ₄₀ Ni ₄₀ B ₂₀	Experiment MS050
Nominal length of nozzle opening	10 mm
Nominal width of nozzle opening	50 μ m
Temp of wheel	RT (~23°C)
Gas in chamber	Argon
Pressure in chamber 12	400 mbar
Temp. of gas in chamber 12	RT
Ejection temperature	1400°C
Ejection pressure	1400 mbar
Surface speed of wheel	59.4m/s
Diameter of wheel	200 mm
Distance between nozzle and wheel	0.3 mm
Width of the resultant fibers	Max 148.3 μ m , min 2.7 μ m
Thickness of the resultant fibers	< 5 μ m

Example 7 - Inventive example

Material: Fe ₄₀ Ni ₄₀ B ₂₀	Experiment MS049
Nominal length of nozzle opening	10 mm
Nominal width of nozzle opening	25µm
Temp of wheel	RT (~23°C)
Gas in chamber	Argon
Pressure in chamber 12	400 mbar
Temp. of gas in chamber 12	RT
Ejection temperature	1400°C
Ejection pressure	1900 mbar
Surface speed of wheel	59.4m/s
Diameter of wheel	200 mm
Distance between nozzle and wheel	0.3 mm
Width of the resultant fibers	Max 180.7µm , min 2.1 µm
Thickness of the resultant fibers	< 5µm

Example 8 - Inventive example

Material: Stainless steel V2A	Experiment MS058
Nominal length of nozzle opening	10 mm
Nominal width of nozzle opening	75 μ m
Temp of wheel	RT (~23°C)
Gas in chamber	Argon
Pressure in chamber 12	400 mbar
Temp. of gas in chamber 12	RT
Ejection temperature	1550°C
Ejection pressure	1200 mbar
Surface speed of wheel	59.4m/s/95 Hz
Diameter of wheel	200 mm
Distance between nozzle and wheel	0.3 mm
Width of the resultant fibers	Max 143.9 μ m , min 2.3 μ m
Thickness of the resultant fibers	< 5 μ m

- 5 The values for both the comparative example 1 and for the inventive examples 2 to 8 are summarized - together with other relevant values - in the Table of Fig. 6 classified by the experiment number. Further inventive examples 9 to 16 are included in the table of Fig.6. Where available SEM micrographs and photographs of the relevant fibers are shown in Figs. 7 to 13 and identified by the Experiment
- 10 number (MS plus three digits).

The Table of Fig. 6 also includes mean values for the width of the microfibers that are produced.

Although the spacing between the nozzle opening and the wheel was 300mm in the Examples given experiments have shown that choosing spacings between 100 and 300mm; has not had any measurable influence on the microfibers produced.

- 5 In all experiments the diameter of the wheel was 200mm.

5

Patent Claims

1. An apparatus for producing elongate microfibers of metal, of metallic glasses or of inorganic material, the apparatus comprising a rotatable wheel (B) having a planar external circumferential surface (S), which is flat in a direction parallel to the axis of rotation of the wheel (B), at least one nozzle (N) having a nozzle opening for directing a molten material onto the circumferential surface (S), with the nozzle having a rectangular cross section and a width (W) of a slit of the nozzle opening in the circumferential direction of the wheel being selected to lie in the range from 10 to 500 μm , and a collection means (14) for collecting solidified fibers of material formed on the circumferential surface from the molten material and separated from the circumferential surface by centrifugal force generated by rotation of the wheel (B), wherein the apparatus comprises a further apparatus that is configured to control a gas pressure (ΔP) applied to the molten material which moves the molten material through the nozzle opening and delivers it to the circumferential surface of the rotatable wheel (B) and wherein the further apparatus is further configured to regulate the mass flow of molten material down to a level at which microfibers of the material are formed on the rotatable wheel (B) by controlling and keeping the mass flow per unit area of the wheel surface (M_{fa}) of the molten material which is deposited per unit of area onto the circumferential surface of the rotatable wheel in the range from 0.01 to 100g/ ($\text{m}^2 \cdot \text{sec}$) for a surface speed of rotation of the wheel in the range from 10 to 100m/sec.

2. An apparatus in accordance with claim 1, wherein the nozzle a length (L) transverse to the circumferential surface of the wheel which is greater than the width (W).
- 5 3 An apparatus in accordance with claim 1 or claim 2, wherein the mass flow per unit area of the wheel surface (M_{fa}) of the molten material which is deposited per unit of area onto the circumferential surface of the rotatable wheel is controlled and kept in the range from between 0.1 and 50g/
10 $(m^2 \cdot sec)$, particularly between 0.2 and 30g/ $(m^2 \cdot sec)$ and ideally around 0.4g/ $(m^2 \cdot sec)$ for a surface speed of rotation of the wheel in the range from 10 to 100m/sec.
4. An apparatus in accordance with any one of the preceding claims, wherein
15 a controller is provided for keeping the speed of rotation of the wheel constant so that the surface speed of the wheel is in the range from 40 to 60m/s.
5. Apparatus in accordance with any one of the preceding claims, wherein the
20 nozzle has a rectangular cross section and the width (W) of the opening of the slit of the nozzle in the circumferential direction of the wheel is selected to lie in the range from 20 to 500 μm and especially in the range from 20 to 100 μm .
6. Apparatus in accordance with any one of the preceding claims in which the
25 length (L) of the slit corresponds to the width of the external circumferential surface of the wheel in a direction parallel to the axis of rotation thereof.
7. Apparatus in accordance with any one of the preceding claims in which the temperature of the melt is kept 100 to 400 °C greater than the melting point of the material.

8. Apparatus in accordance with any one of the preceding claims in which the pressure exerted on the melt upstream of the nozzle is controlled to be higher than the pressure prevailing in the melt spinning chamber by an amount in the range from ΔP equal to 0 to 5000 mbar.
- 5
9. An apparatus in accordance with any one of the preceding claims, wherein the rotatable wheel (B) is temperature controlled and preferably e.g. to a temperature in the range of -100 °C to + 200°C.
- 10 10. An apparatus in accordance with any one of the preceding claims, wherein the wheel (B) is made of a metal, for example copper, or stainless steel, or of a metal alloy or of a ceramic material or of graphite or is a wheel of a base material having a layer or tire made of a metal or of a metal alloy or of a ceramic material or of graphite or a vapor deposited carbon, for example
- 15 a copper wheel having a layer of graphite.
11. An apparatus in accordance with any one of the preceding claims wherein said wheel is mounted to rotate within a chamber (12) having an atmosphere, the atmosphere being at least one of air, nitrogen, helium and
- 20 other inert gasses.
12. An apparatus in accordance with any one of the preceding claims, wherein said wheel is mounted to rotate within a chamber (12) having an atmosphere at a pressure corresponding to the ambient atmospheric
- 25 pressure, or to a lower pressure than ambient pressure.
13. A method for producing elongate microfibers of metal, or metallic glasses or of inorganic material having a median width of 50 μm or less, a thickness of 5 μm or less and a length at least ten times greater than said width, the
- 30 method comprising the steps of directing a molten material through a nozzle

5 onto a planar external circumferential surface of a rotating wheel (B), with the nozzle having a nozzle opening for directing a molten material onto the circumferential surface (S), with the nozzle having a rectangular cross section and a width (W) of a slit of the nozzle opening in the circumferential direction of the wheel being selected to lie in the range from 10 to 500 μm , by applying a gas pressure to the molten material to move it through the nozzle opening and deliver it to the circumferential surface (S) of the rotatable wheel, and collecting solidified fibers formed on the circumferential surface (S) from the molten material and separated from the circumferential surface by centrifugal force generated by rotation of the wheel (B), the method further comprising the steps of selecting the dimensions and geometry of the nozzle in combination with the gas pressure (ΔP) to regulate the mass flow of molten material (Mfa) which is deposited per unit of area onto the circumferential surface of the rotatable wheel to a value in the range from 0.01 to 100g/ (m²*sec), especially between 0.1 and 50g/ (m²*sec), particularly between 0.2 and 30g/ (m²*sec) and ideally around 0.42g/s (m²*sec) for a surface speed of rotation of the wheel in the range from 10 to 100m/sec to form microfibers of the material on the rotatable wheel (B) by reducing the flow rate of molten material onto the circumferential surface of the wheel in a material dependent manner to a level at which it is concentrated by the forces that are acting to produce the desired elongate fibers of the material.

14. A method in accordance with claim 13, wherein the flow of metal is reduced to a level at which the elongated fibers have a width of 200 μm to < 1 μm , preferably of 150 μm to < 1 μm and especially of < 50 μm to < 1 μm or smaller.

15. A method in accordance with either of claims 13 or 14, wherein the fibers have a thickness of $\leq 5\mu\text{m}$ to < 1 μm or smaller.

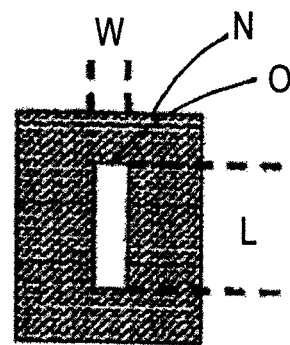
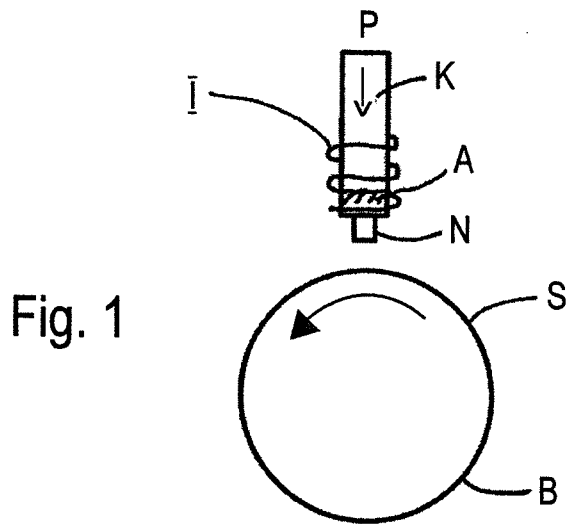

Fig. 4

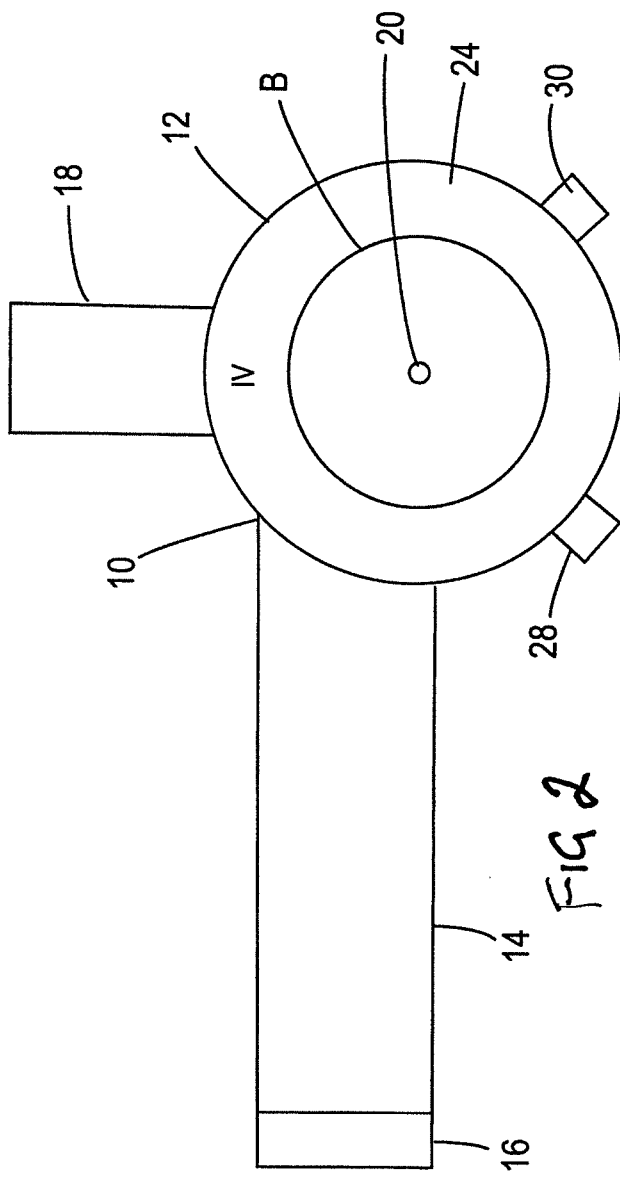

Fig. 2

FIG 2

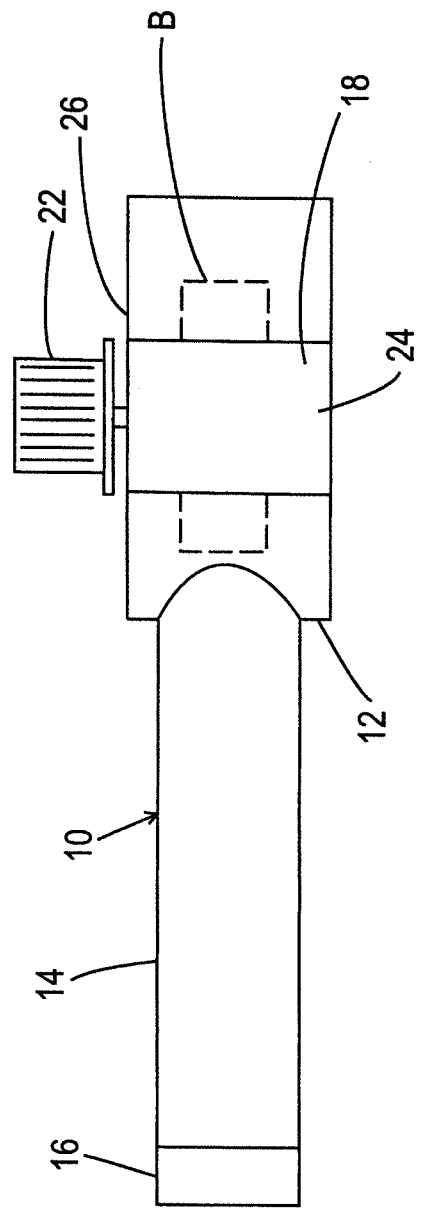

Fig. 3

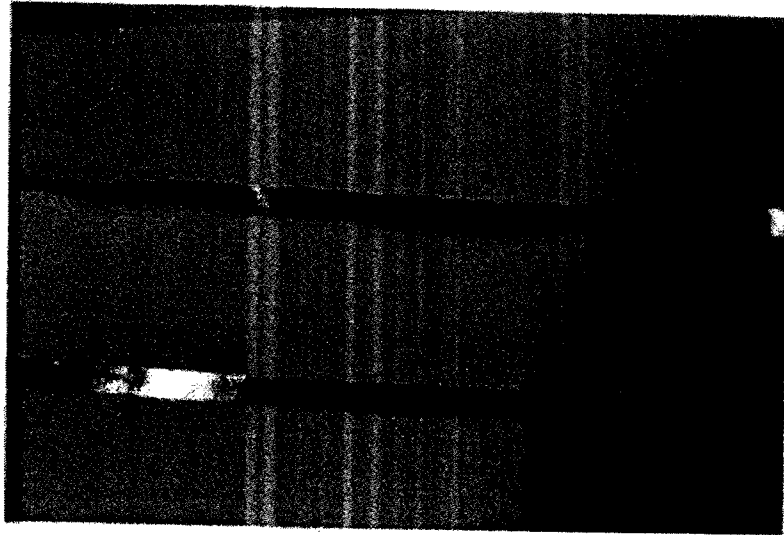

Fig. 5

Fig. 6

Examples/ exp. #	material	wheel surface	nozzle slit width (μm)	wheel surface speed (m/s)	pressure difference (mbar)	pressure in the chamber (mbar)	median width (μm)	mean (μm)	SD (μm)	max. fiber width (μm)	min. fiber width (μm)	fiber thicknes s (μm)	ejection temperatu re ($^{\circ}\text{C}$)	MF (mass of fiber (g/sec))
1/MS	$\text{Fe}_{40}\text{Ni}_{40}\text{B}_{20}$	flat	400	18.8	200	400	flat ribbon 1cm in width					< 40	1350	< 100
2/48	$\text{Fe}_{40}\text{Ni}_{40}\text{B}_{20}$	flat	400	59.4	200	400	137.3	< 5	216.2	1296.0	6.3	< 5	1400	< 5
3/47	$\text{Fe}_{40}\text{Ni}_{40}\text{B}_{20}$	flat	200	59.4	200	400	41.1	< 5	65.7	335.9	3.0	< 5	1400	< 5
4/45	$\text{Fe}_{40}\text{Ni}_{40}\text{B}_{20}$	flat	100	59.4	400	400	24.8	< 5	46.9	216.1	3.1	< 5	1400	< 5
5/51	$\text{Fe}_{40}\text{Ni}_{40}\text{B}_{20}$	flat	75	59.4	600	400	17.5	< 5	23.5	94.0	2.3	< 5	1400	< 5
6/50	$\text{Fe}_{40}\text{Ni}_{40}\text{B}_{20}$	flat	50	59.4	1000	400	15.8	< 5	22.3	148.3	2.7	< 5	1400	< 5
7/49	$\text{Fe}_{40}\text{Ni}_{40}\text{B}_{20}$	flat	25	59.4	1500	400	14.8	< 5	24.5	180.7	2.1	< 5	1400	< 5
8/58	stainless steel	flat	75	59.4	800	400	22.0	< 5	31.7	143.9	2.3	< 5	1550	< 5
9/41	$\text{Fe}_{40}\text{Ni}_{40}\text{B}_{20}$	flat	50	53.1	1000	400	12.1	< 5	9.0	52.2	7.1	< 5	1350	< 5
10/42	$\text{Fe}_{40}\text{Ni}_{40}\text{B}_{20}$	flat	50	53.1	1000	400	17.4	< 5	22.5	211.0	2.5	< 5	1350	< 5
11/43	$\text{Fe}_{40}\text{Ni}_{40}\text{B}_{20}$	flat	50	53.1	1500	400	14.6	< 5	19.8	97.6	2.8	< 5	1378	< 5
12/44	$\text{Fe}_{40}\text{Ni}_{40}\text{B}_{20}$	flat	75	53.1	600	400	23.5	< 5	27.9	138.8	3.2	< 5	1352	< 5
13/45	$\text{Fe}_{40}\text{Ni}_{40}\text{B}_{20}$	flat	100	53.1	400	400	24.8	< 5	46.9	216.1	3.1	< 5	1400	< 5
14/46	$\text{Fe}_{40}\text{Ni}_{40}\text{B}_{20}$	flat	50	62.5	1500	400	12.5	< 5	24.6	159.1	0.8	< 5	1400	< 5
15/54	Zn	flat	50	59.4	1000	400	-	< 5	-	1000.0	-	< 5	700	< 5
16/56	Al	flat	50	59.4	1000	400	-	< 5	-	1000.0	-	< 5	800	< 5

MS048

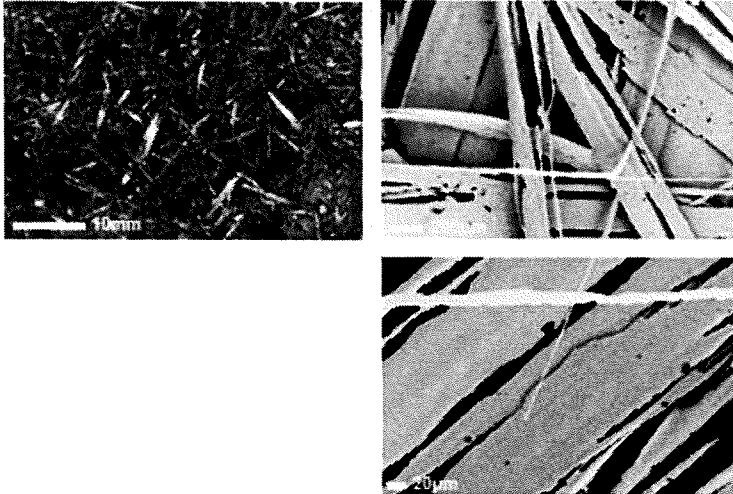

Fig. 7

MS047

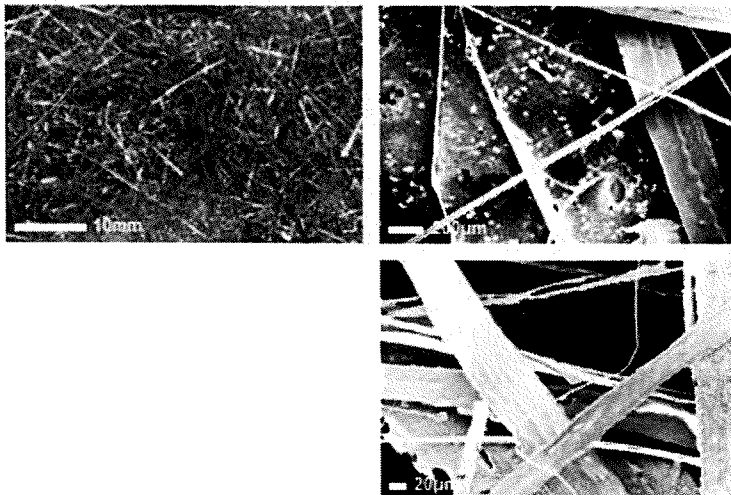

Fig. 8

MS045

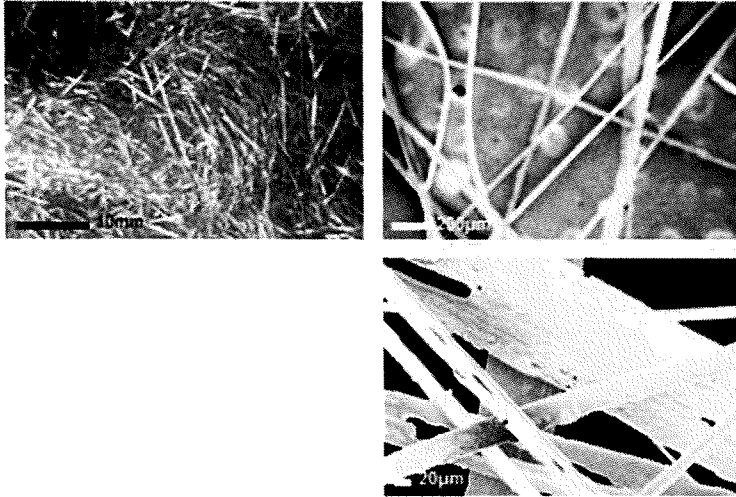

Fig. 9

MS051

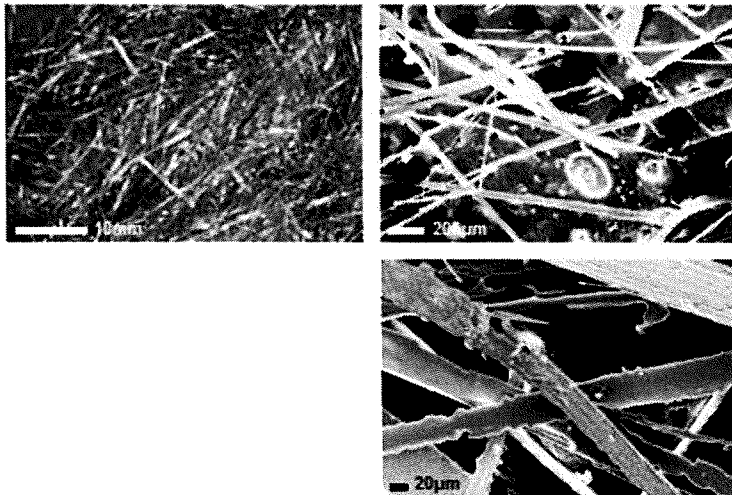

Fig. 10

MS050

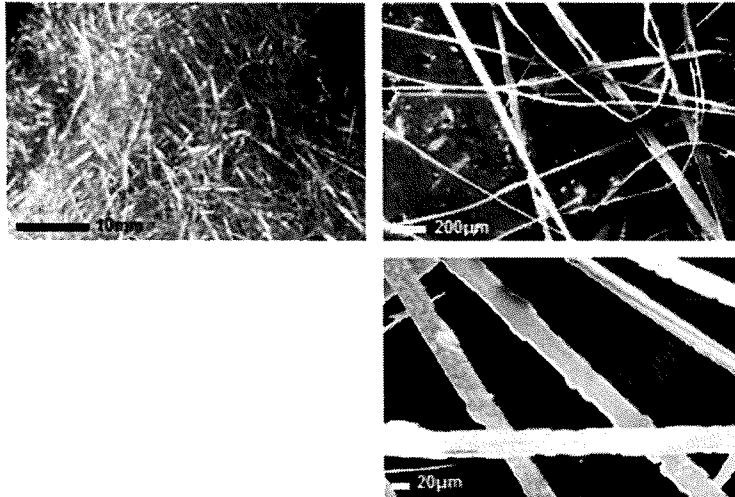

Fig. 11

MS049

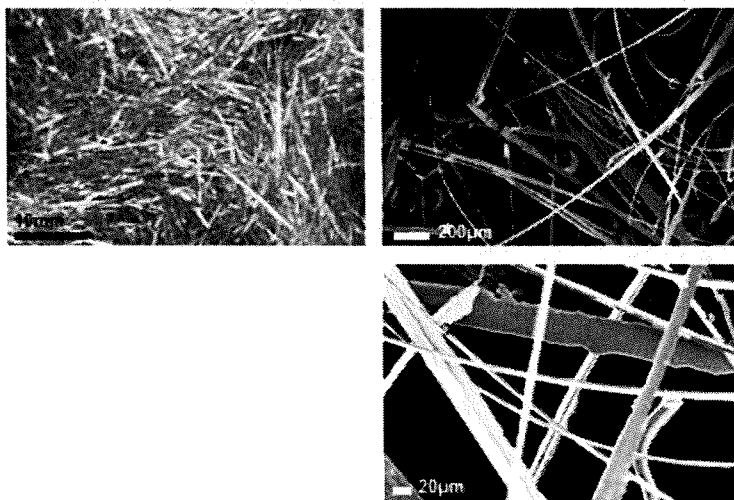

Fig. 12



MS046 SEM-198x



MS046 SEM-201x

FIG. 13

INTERNATIONAL SEARCH REPORT

International application No
PCT/EP2016/070963

A. CLASSIFICATION OF SUBJECT MATTER
INV. B22D11/06 DOIF/00
 ADD.
 According to International Patent Classification (IPC) or to both national classification and IPC

B. FIELDS SEARCHED
 Minimum documentation searched (classification system followed by classification symbols)
B22D D01F

Documentation searched other than minimum documentation to the extent that such documents are included in the fields searched

Electronic data base consulted during the international search (name of data base and, where practicable, search terms used)
EPO-Internal , WPI Data

C. DOCUMENTS CONSIDERED TO BE RELEVANT

Category*	Citation of document, with indication, where appropriate, of the relevant passages	Relevant to claim No.
Y	KIM S W ET AL: "Manufacture and Industrial Application of Fe-based Metallic Glasses" , MATERIALS SCIENCE FORUM, TRANS TECH PUBLICATIONS LTD- SWITZERLAND, CH, vol . 706-709 , 1 January 2012 (2012-01-01) , pages 1324-1330, XP002754862 , ISSN : 0255-5476, DOI : 10.4028/WWW.SCI ENTI F _C. NET/MSF.706-709 . 1324	1-5 ,7-12
A	[retrieved on 2012-01-03] page 1325 - page 1326 ----- -/- .	6, 13-15

Further documents are listed in the continuation of Box C.

See patent family annex.

* Special categories of cited documents :

"A" document defining the general state of the art which is not considered to be of particular relevance

"E" earlier application or patent but published on or after the international filing date

"L" document which may throw doubts on priority claim(s) or which is cited to establish the publication date of another citation or other special reason (as specified)

"O" document referring to an oral disclosure, use, exhibition or other means

"P" document published prior to the international filing date but later than the priority date claimed

"T" later document published after the international filing date or priority date and not in conflict with the application but cited to understand the principle or theory underlying the invention

"X" document of particular relevance; the claimed invention cannot be considered novel or cannot be considered to involve an inventive step when the document is taken alone

"Y" document of particular relevance; the claimed invention cannot be considered to involve an inventive step when the document is combined with one or more other such documents, such combination being obvious to a person skilled in the art

"&" document member of the same patent family

Date of the actual completion of the international search

8 November 2016

Date of mailing of the international search report

17/11/2016

Name and mailing address of the ISA/

European Patent Office, P.B. 5818 Patentlaan 2
 NL - 2280 HV Rijswijk
 Tel. (+31-70) 340-2040,
 Fax: (+31-70) 340-3016

Authorized officer

Zimmermann , Frank

INTERNATIONAL SEARCH REPORT

International application No
PCT/EP2016/070963

C(Continuation). DOCUMENTS CONSIDERED TO BE RELEVANT		
Category*	Citation of document, with indication, where appropriate, of the relevant passages	Relevant to claim No.
Y	SUNG J K ET AL: "Theoretical expectation of strip thickness in planar flow casting process" , MATERIALS SCIENCE AND ENGINEERING A: STRUCTURAL MATERIALS: PROPERTIES, MICROSTRUCTURES AND PROCESSING, ELSEVIER BV, NL, vol . A181-A182 , 1 January 1994 (1994-01-01) , pages 1237-1242 , XP002754863 , ISSN: 0921-5093 , DOI : 10.1016/0921-5093 (94)90838-9 [retrieved on 2003-05-12]	1-5 ,7-12
A	page 1237 - page 1238 -----	6 , 13-15
A	JECH ROBERT W ET AL: "Rapid Solidification Via Melt Spinning: Equipment and Techniques" , JOURNAL OF METALS, SPRINGER-VERLAG, NEW YORK, vol . 36, no. 4 , 20 December 2013 (2013-12-20) , pages 41-45 , XP035303445 , ISSN: 0148-6608, DOI : 10.1007/BF03338425 [retrieved on 2013-12-20] page 41 - page 43 -----	1-15
A	EP 0 055 827 A1 (ALLIED CORP [US]) 14 July 1982 (1982-07-14) the whole document -----	1-15
A	AHMED K JASSIM ET AL: "Sustainable Manufacturing Process for Bulk Metallic Glasses Production Using Rapid Solidification with Melt Spinning Technique" , PROCEEDINGS OF 2014 INTERNATIONAL CONFERENCE ON MATERIAL SCIENCE AND MATERIAL ENGINEERING (MSME 2014) ; MARCH 15 - MARCH 16, 2014, CHICAGO, ILLINOIS, USA, , 15 March 2014 (2014-03-15) , pages 1-12 , XP002754864, ISBN : 978-1-60595-171-3 the whole document -----	1-15
A	JP H06 55247 A (TOYO BOSEKI) 1 March 1994 (1994-03-01) abstract -----	1-15
A	US 5 213 151 A (HACKMAN LLOYD E [US]) 25 May 1993 (1993-05-25) the whole document -----	1-15
	----- -/--	

INTERNATIONAL SEARCH REPORT

International application No
PCT/EP2016/070963

C(Continuation). DOCUMENTS CONSIDERED TO BE RELEVANT		
Category*	Citation of document, with indication, where appropriate, of the relevant passages	Relevant to claim No.
A	US 6 626 228 B1 (BEWLAY BERNARD PATRICK [US] ET AL) 30 September 2003 (2003-09-30) the whole document	1-15
A	----- LIEBERMANN H H ET AL: "Production of amorphous alloy ribbons and effects of apparatus parameters on ribbon dimensions", IEEE TRANSACTIONS ON MAGNETICS, IEEE SERVICE CENTER, NEW YORK, NY, US, vol. 12, no. 6, 1 November 1976 (1976-11-01), pages 921-923, XP002745621, ISSN: 0018-9464, DOI: 10.1109/TMAG.1976.1059201 [retrieved on 2003-01-06] cited in the application the whole document	1-15
A	----- LIEBERMANN ET AL: "The dependence of the Geometry of glassy alloy ribbons on the chill block melt-spining process parameters", MATERIALS SCIENCE ENGINEERING, ELSEVIER SEQUOIA, LAUSANNE, CH, vol. 43, no. 3, 1 May 1980 (1980-05-01), pages 203-210, XP024085093, ISSN: 0025-5416, DOI: 10.1016/0025-5416(80)90103-2 [retrieved on 1980-05-01] the whole document	1-15

INTERNATIONAL SEARCH REPORT

Information on patent family members

International application No PCT/EP2016/070963
--

Patent document cited in search report	Publication date	Patent family member(s)	Publication date
EP 0055827	AI	14-07-1982	DE 3168700 DI 14-03-1985
			EP 0055827 AI 14-07-1982
			JP S57134251 A 19-08-1982

JP H0655247	A	01-03 -1994	JP 3144080 B2 07-03-2001
			JP H0655247 A 01-03-1994

US 5213151	A	25-05 -1993	AU 5007993 A 15-03-1994
			CA 2142855 AI 03-03-1994
			JP H08500294 A 16-01-1996
			US 5213151 A 25-05-1993
			Wo 9404296 AI 03-03-1994

US 6626228	BI	30-09 -2003	NONE
