

Efficient and reversible CO2 capture in bio-based ionic liquids solutions

*Original*

Efficient and reversible CO2 capture in bio-based ionic liquids solutions / Latini, Giulio; Signorile, Matteo; Rosso, Francesca; Fin, Andrea; D'Amora, Marta; Giordani, Silvia; Pirri, Candido; Crocellà, Valentina; Bordiga, Silvia; Bocchini, Sergio. - In: JOURNAL OF CO2 UTILIZATION. - ISSN 2212-9820. - ELETTRONICO. - 55:(2022), p. 101815. [10.1016/j.jcou.2021.101815]

*Availability:*

This version is available at: 11583/2947884 since: 2021-12-27T18:23:27Z

*Publisher:*

Elsevier Ltd.

*Published*

DOI:10.1016/j.jcou.2021.101815

*Terms of use:*

This article is made available under terms and conditions as specified in the corresponding bibliographic description in the repository

*Publisher copyright*

(Article begins on next page)

# Simulation and testing of a hydraulic winch

Cite as: AIP Conference Proceedings 2191, 020135 (2019); <https://doi.org/10.1063/1.5138868>  
Published Online: 17 December 2019

Massimo Rundo, and Alessandro Corvaglia



View Online



Export Citation

## Lock-in Amplifiers up to 600 MHz



Zurich  
Instruments



# Simulation and testing of a hydraulic winch

Massimo Rundo<sup>a)</sup> and Alessandro Corvaglia<sup>b)</sup>

*Department of Energy, Politecnico di Torino,  
C.so Duca degli Abruzzi 24, 10129, Turin, Italy*

<sup>a)</sup>Corresponding author: massimo.rundo@polito.it

<sup>b)</sup>alessandro.corvaglia@polito.it

**Abstract.** The paper presents the lumped parameter model of a hydraulic winch developed in the Simcenter Amesim environment. It includes a detailed model of a load sensing direction control valve and of an overcentre valve for controlling an orbit motor with holding brake. The model of the winch, validated on a test rig in terms of pressure drop across the motor, has been used for analyzing different control strategies for obtaining the same velocity profile of the shaft and the total hydraulic energy supplied by the load sensing pump has been evaluated. As a first step, the independent metering architecture has been implemented. An additional simplification of the system was the removal of the local pressure compensator and the control of the speed in a closed loop using as feedback signal the output of an integrated tachometer. As a last step, the overcentre valve has been removed and the overrunning load has been imposed by a meter-out control of the flow rate.

## INTRODUCTION

In fluid power systems employed in lifting machines, such as cranes or telehandlers, the overrunning load must be handled in order to avoid the uncontrolled speed of the actuators. The typical method is the use of counterbalance or overcentre valves active at the outlet of the hydraulic actuator with the aim of generating a back pressure for balancing the overrunning load [1, 2]. Moreover this kind of components are commonly used for the working hydraulics of valve-controlled mobile machines, as excavators or wheel loaders [3]. Overcentre valves are reliable components for holding the load thanks to their leak-proof design and for controlling the lowering phase of the load, however they are a huge source of power dissipation and the pump remains under pressure even when the load is overrunning. Moreover stability issues can occur [4].

Due to the stringent engine emission regulations, the optimization of the hydraulic circuits of mobile systems is becoming more and more important. Several studies have been carried out about different subsystems such as the hydrostatic steering units [5], the hydrostatic transmissions [6] or the coupling between the engine and the pump [7]. Other studies are oriented on the analysis of proportional valves for controlling the direction and the speed of the actuators [8]. More specific research activities are focused on component-level CFD analyses of direction and flow control valves [9, 10]. However the current trend is to redesign the architecture of the hydraulic circuits for mobile machines in order to limit the flow throttling. This target can be obtained by reducing the pump margin [11] or by adopting the independent metering layout [12, 13]. Other solutions applied specifically to winches involve the complete removal of the valves and the use of closed digital hydraulic circuits [14].

In the present paper a hydraulic winch made up by an orbit motor with mechanical brake and overcentre valve is modeled and the energy absorbed by the pump in a lifting/lowering cycle is evaluated. Subsequently, two new layouts are introduced and analyzed in terms of energy saving.

## SYSTEM DESCRIPTION

The circuit under study is part of a more complex system installed at the Fluid Power Research Laboratory of the Politecnico di Torino [15]. It includes a test rig that reproduces the hydraulic circuit based on Load Sensing architecture of a fork lift truck with hydrostatic steering unit and proportional direction control valves. A separate rig houses a hydraulic winch and the components for generating the resistant and the overrunning torque on the shaft. Finally, a flow generating group, made up of four pumps, is located downstairs for feeding the load sensing test rig and for simulating the load on the actuators. A simplified hydraulic scheme, including only the components involved in the present study, is shown in Fig. 1. A 40 cc/rev radial piston pump (PU1) with load sensing displacement control feeds a Danfoss PVG32 proportional valve with electro-hydraulic control and nominal flow rate of 40 L/min. The winch (primary circuit) is made up of an orbit motor Danfoss OMT 160 FH with a displacement of 161.1 cc/rev with integral holding brake (M1) and an overcentre valve (OVC) Oleostar VOSLA 12/3 with pilot ratio 3, internal non-return valve and shuttle valve for the pilot signal for the brake release. The machine M1 is mechanically connected to a similar orbit motor OMT 160 EM with speed sensor (M2) and a flywheel with variable inertia is mounted on the shaft. The unit M2 works in a closed circuit, where the proportional relief valve RV and the pre-charged non-return valve NR control respectively the high and the low pressure levels, regardless of the direction of rotation.

The condition of resistant load is obtained when the PVG32 feeds the port A of the motor M1 and the direction control valve D4/2 is kept at rest. In this way the machine M2 works as a pump and the flow rate is delivered through the port 2; thanks to the non-return valves, the relief valve RV is forced to regulate and it imposes the high pressure level decided by the user. The pump PU2, with a displacement of 20 cc/rev, behaves as charge pump for compensating the leakages in the closed circuit and the excess flow is discharged to the reservoir through the valve NR.

For the generation of the overrunning load, the valve D4/2 is energized and the pump PU2 feeds the port 2 of the machine M2 that now works as a motor. The excess flow is still discharged by the proportional relief valve that now controls the inlet pressure. For managing this load condition, the proportional valve must feed the port B of the machine M1, in order to have the regulation of the overcentre valve. The working fluid is an ISO VG 46 Mobil DTE 25 oil.

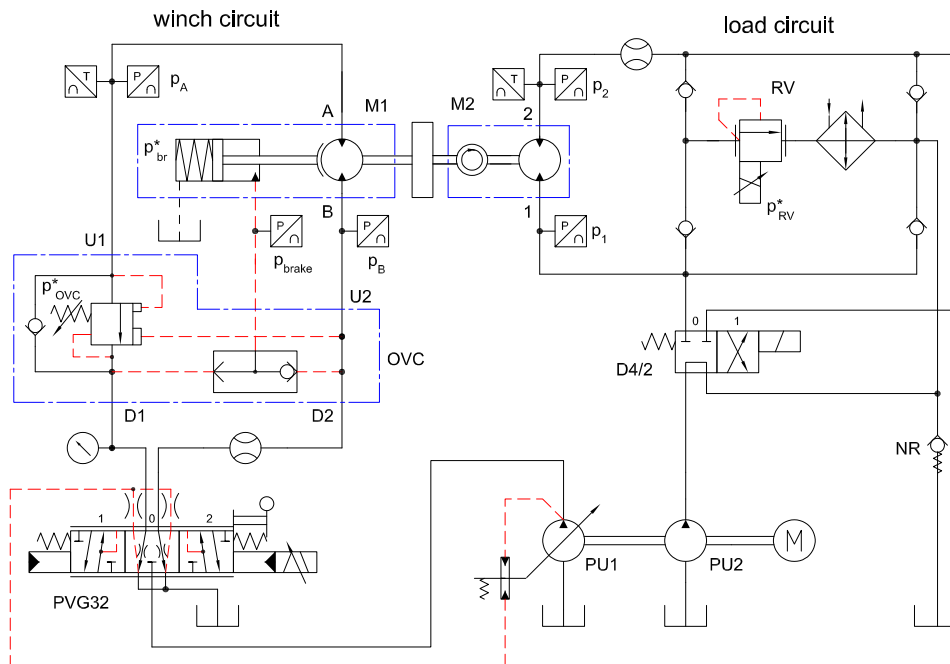
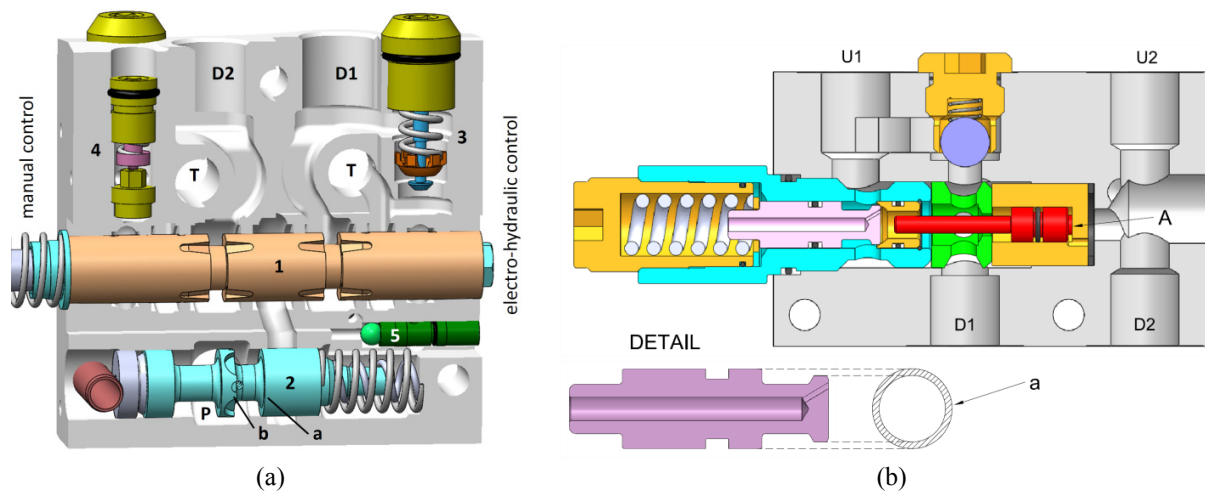

FIGURE 1. Hydraulic scheme of the circuit for testing the winch.

The circuit is equipped with several sensors, more in details:

- five pressure transducers Trafag 8891 with measuring range 0-250 bar and accuracy  $\pm 0.3\%$  F.S.
- two gear flowmeters VSE EF2 with measuring range 0.5-70 L/min and accuracy 2%
- two thermistors Pt100 Italcoppie

In Fig. 2a the section view of the work module of the PVG32 valve is shown. The electro-hydraulic device for controlling the spool position is located on the right side (not shown). The main spool (1) features four notches at 90 degrees and in the neutral position both work ports are connected to the reservoir (float-centre). The pressure drop across the notches is kept constant by the regulation of the local compensator (2), located upstream (pre-compensator). In regulating condition the flow is throttled by the land (b) provided with 2 series of semicircular notches, while at rest the connection is closed by the land (a). Two concentric springs exert a force on the spool: only the outer one has a preload, while the inner, at rest, is floating. In the figure also the antishock-anticavitation valves (3), the local load sensing relief valves (4) and the shuttle valve (5) for selecting the pressure of the work port are shown. A section view of the overcentre valve is reported in Fig. 2b. The opening forces on the poppet are generated by a small actuator with surface of influence “A” on which the cross-pilot pressure acts and by the back pressure of the motor M1 acting on the annular surface “a” highlighted in the detail.



**FIGURE 2.** (a) Section view of the Load Sensing direction control valve Danfoss PVG32; (b) section view of the overcentre valve Oleostar VOSLA 12/3 with the detail of the poppet.

## SIMULATION MODEL

The hydraulic circuit of the winch shown in Fig. 1 has been simulated in the Simcenter Amesim environment (Fig. 3). The PVG32 work module and the overcentre valve have been modeled in a very detailed way by means of the Hydraulic Component Design library. In the local compensator the flow area has been simulated analytically by setting the geometry of the semicircular notches, while for the main spool a look-up table has been supplied. The model of the PVG32 has been validated in a previous study [16]. The restrictor R1 takes into account the pressure drop on the return line (pipes, quick couplings, heat exchanger, filter) and its flow-pressure characteristic has been measured experimentally. This restrictor has an influence on the equilibrium of the overcentre valve, since the pressure at the port D1 is also active in the spring chamber. Also the overcentre valve has been simulated in a detailed way. In order to eliminate the uncertainty due to the friction force on the moveable elements, the O-rings on the small actuator with surface A and on the poppet have been removed in the real component. The volumetric and mechanical-hydraulic efficiencies of the orbit motor M2 have been evaluated experimentally as function of the pressure drop at two speed values (50 and 150 rpm). The same efficiencies have been assumed also for the motor M1, since this machine, except for the accessories, is identical to the motor M2. In the model, the analytic expressions interpolating the measured efficiencies as function of the pressure have been supplied. The braking torque has been simulated by considering a linear relationship with the pilot pressure as expressed by the Eq. (1):



driving torque. With resistant load the delivery pressure of the pump ( $p_A$ ) increases with the torque, while the outlet pressure ( $p_B$ ) is constant, since it is due to the pressure losses in the circuit with constant flow rate. The upward translation of the curves with overrunning load is due to the higher compression of the spring of the overcentre valve when the flow rate increases.

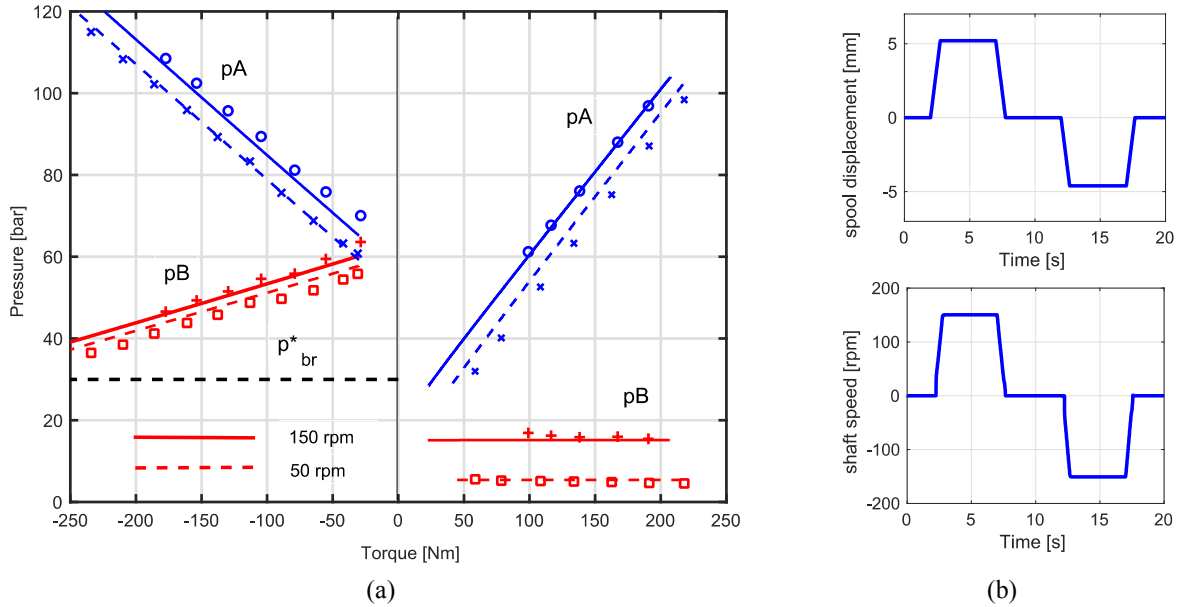

**FIGURE 4.** (a) Experimental (indicators) and simulated (continuous lines) pressures across the motor M1 as function of the torque with resistant (positive) and overrunning (negative) load for two different constant speeds; (b) spool displacement of the PVG32 valve and corresponding speed of the motor M1 used for the simulation of the working cycle lifting/lowering.

For the analysis of the absorbed energy, a lifting/lowering cycle has been simulated at constant torque. In Fig. 4b the displacement of the main spool of the PVG32 module and the corresponding angular speed of the shaft are plotted as function of the time. The positive velocity corresponds to the lifting phase, namely with resistant load. In the second part of the cycle the load is controlled by the overcentre valve. The flow rate through the circuit for obtaining the speed of 150 rpm is about 25 L/min. At the end of the cycle, the hydraulic energy delivery by the pump to the circuit is calculated through the transducer E. The results are shown in the next section.

## ANALYSIS OF DIFFERENT LAYOUTS

The reference system has been virtually contrasted with two new layouts. In the first the overrunning load is still controlled by the overcentre valve, however the pressure drops in the proportional valve have been reduced by adopting the independent metering architecture (Fig. 5). In this way the spool at the outlet can be left fully open. An additional modification is the removal of the local compensator and the closed loop control of the speed by acting on the position of the spool at the inlet. This last feature has no influence on the absorbed energy, since the elimination of the pressure drop across the compensator is balanced by a high pressure drop across the main spool in order to obtain the same flow rate. However it could be easily implemented, since in the real system the motor M2 is already provided with a speed transducer and it allows a simplification of the hydraulic valve. For the lifting phase the valve V1 works in an intermediate position between 0 and 1 for supplying the desired flow in order to control the speed of the motor, while the valve V2 is maintained completely open in the position 2 by the ECU. For the lowering phase the valve V2 modulates the flow area between the position 0 and 1, while the valve V1 is in the position 2. The external shuttle valve SV1 selects the load sensing signal.

In the second solution analyzed (Fig. 6), the overcentre valve has been removed, therefore with overrunning load the shaft speed is controlled by means of the outlet valve (meter-out control). In this way the pump delivery pressure is maintained at a lower value with a significant reduction of the absorbed power. With this layout only the valve V1 needs to be proportional, while the valve V2 can be simply ON/OFF.

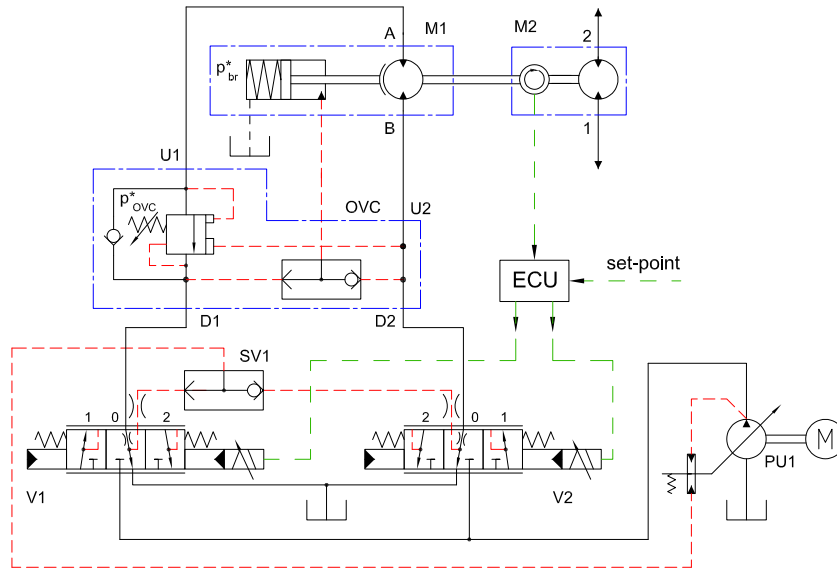

**FIGURE 5.** Hydraulic scheme of the architecture with independent metering and without the local compensators.

The lifting phase is similar as in the case of Fig. 5, in fact the pressure at port A generates both the load sensing and the brake signals. For the lowering phase the valve V2 works in the position 1, while the valve V2 throttles the flow area between the position 0 and 2. The brake is released by the pressure at the outlet of the motor thanks to the shuttle valve SV2, while the shuttle valve SV1 connects the inlet port of the motor with the load sensing line. However, in order to limit the absorbed torque the load sensing pressure is limited by a relief valve with setting  $p_s^*$ . Ideally the delivery pressure could be maintained very low when the load is overrunning, since the brake is released by the pressure induced by the valve V1. The problem arises during the start-up phase, because it is not possible to increase the outlet pressure ( $p_d$ ) if the shaft does not rotate and in this case the valve SV2 select the pressure  $p_B$  for releasing the brake. Hence the setting  $p_s^*$ , incremented by the pump margin (15 bar), must be greater than  $p_{br}^*$ . In the present study  $p_s^*$  20 bar, so that the delivery pressure is imposed at 35 bar.

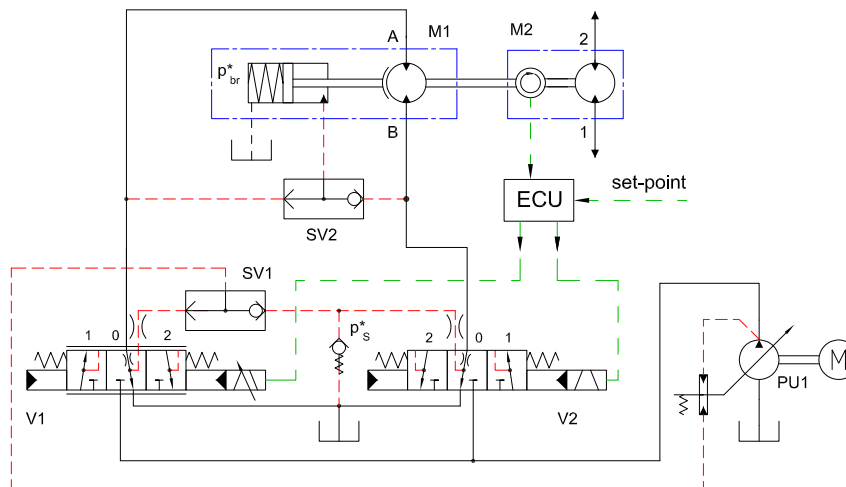

**FIGURE 6.** Hydraulic scheme of the architecture without the overcentre valve.

In both solutions a proportional-integral controller can be implemented in the ECU. However this first study does not deal with the optimization of the control algorithm in terms of dynamic response, but only on the potential

energy saving. Therefore the only aspect that has been considered is the capability of the system in obtaining the same speed profile shown in Fig. 4b.

The hydraulic energy delivered without local compensator (no LC) and also without the overcentre valve (no OVC) is contrasted with the reference layout in Fig. 7a in the lifting/lowering cycle at maximum (450 Nm) and partial (150 Nm) load. The pressure setting of the overcentre valve, with respect to the experimental tests, was increased up to 275 bar for maintaining the brake fully released also with the maximum load. In fact the risk is that with overrunning load the pressure  $p_B$  could fall below  $p_{br}^*$ ; the increment of  $p_{OVC}^*$  allows translating upwards the curves in Fig. 4a. With the maximum load the saving is quite limited (5.1%), while with 150 Nm the solution without the overcentre valves leads to a saving of about 27.5%.

In Fig. 7b the contributions to the energy of the lifting and of the lowering phase in the case with partial load is split. It can be observed that the advantage without the overcentre valve is mostly in the lowering phase. In fact in this phase the delivery pressure of the pump is maintained constant at 35 bar, while with the overcentre is function of the pressure  $p_B$  that increases if the load decreases, as shown in Fig. 4a. The delivery pressure in the reference layout could be reduced by decreasing the setting  $p_{OVC}^*$ , but in this way the maximum torque of 450 Nm cannot be reached due to the activation of the brake.

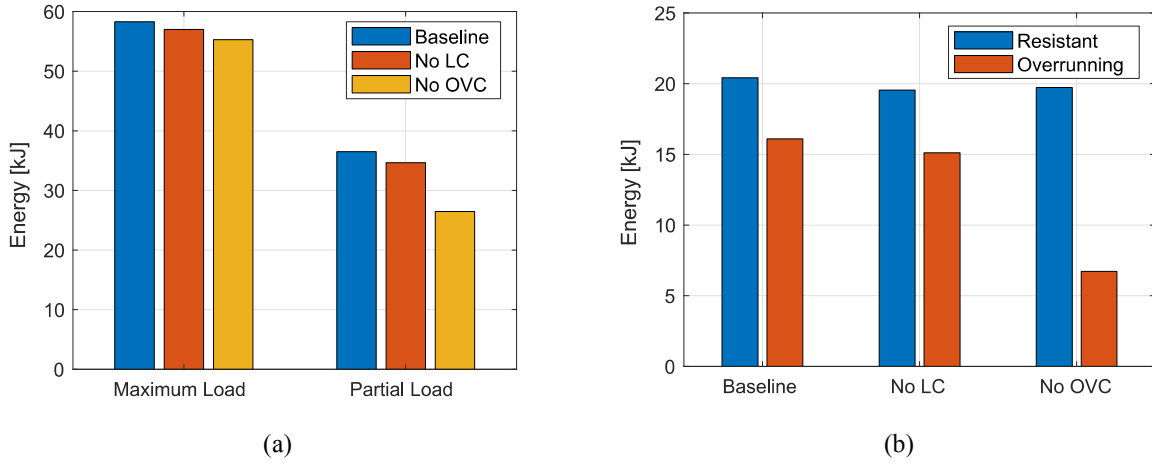

**FIGURE 7.** (a) Simulated hydraulic energies supplied by the pump over a working cycle for three different configurations and two different loads; (b) absorbed energy during the lifting and lowering phase with partial load.

## CONCLUSIONS

In this paper the lumped parameter model of a hydraulic winch is presented. The model is able to reproduce the steady-state characteristic of the fluid power system. Two alternative solutions have been analyzed and contrasted with the original layout in terms of hydraulic energy delivered by the pump. The solution with independent metering and without the local compensator gives negligible improvements. In fact, due to the relatively small flow rate through the original proportional valve, the pressure drops in the return line are of the order of 6 bar, therefore the advantage of keeping fully open the outlet metering edge is quite limited. In the layout without the overcentre valve, with maximum load the advantage is not so high, since in the pump is pressurized at similar levels. However the delivery pressure does not depend on the overrunning torque, while in the original system the pressure increases with the reduction of the load due to the equilibrium condition of the overcentre valve. In this last case the removal of the overcentre valve leads to a significant energy saving.

Further studies could involve the analysis of the dynamic behavior and the integration of the winch in a multi-actuator system.

## NOMENCLATURE

$M_1, M_2$	orbit motors' real torque	$p_{OVC}^*$	pressure setting of the overcenter valve
$M_{br}$	braking torque	$p_S^*$	pressure setting of the load sensing relief valve
$p$	pressure	$p_{br}^*$	pressure setting of the brake
$p_A, p_B$	pressures at ports of motor M1	$V_{br}$	equivalent displacement of the brake
$p_1, p_2$	pressures at ports of motor M2	$V_{M1}, V_{M2}$	displacements of the orbit motors
$p_{br}^*$	pressure setting of the brake	$\Delta M_1, \Delta M_2$	orbit motors' lost torque

## REFERENCES

1. G. Altare, F. Lovuolo, N. Nervegna and M. Rundo, "Coupled Simulation of a Telehandler Forks Handling Hydraulics", *Int. Journal of Fluid Power* 13(2):15-28, 2012. DOI: 10.1080/14399776.2012.10781050.
2. G.F. Ritelli and A. Vacca, "Energetic and dynamic impact of counterbalance valves in fluid power machines", *Energy Conversion and Management* 76: 701–711, 2013. DOI: 10.1016/j.enconman.2013.08.021.
3. G. Altare, D. Padovani and N. Nervegna, "A commercial excavator: Analysis, modelling and simulation of the hydraulic circuit", *SAE Technical Paper 2012-01-2040*, 2012. DOI: 10.4271/2012-01-2040.
4. Y. Yao, H. Zhou, Y. Chen and H. Yang, "Stability Analysis of a Pilot Operated Counterbalance Valve for a Big Flow Rate", Proceedings of the ASME/BATH 2014 Symposium on Fluid Power & Motion Control, September 10-12, Bath, United Kingdom.
5. B. Zardin, M. Borghi, F. Gherardini and N. Zanasi, "Modelling and simulation of a hydrostatic steering system for agricultural tractors", *Energies* 11(1), 230, 2018. DOI: 10.3390/en11010230.
6. A. Rossetti, A. Macor and M. Scamperle, "Optimization of components and layouts of hydromechanical transmissions", *Int. Journal of Fluid Power* 18(2):123-134, 2017. DOI: 10.1080/14399776.2017.1296746.
7. P. Casoli, A. Gambarotta, N. Pompini and L. Riccò, "Development and application of co-simulation and control-oriented modeling in the improvement of performance and energy saving of mobile machinery", *Energy Procedia* 45: 849–858, 2014. DOI:10.1016/j.egypro.2014.01.090.
8. P. Casoli, A. Anthony and L. Riccò, "Modeling simulation and experimental verification of an excavator hydraulic system – Load sensing flow sharing valve model", *SAE Technical Paper 2012-01-2042*, 2012. DOI: 10.4271/2012-01-2042.
9. A. Senatore, D. Buono, E. Frosina, M. Pavanetto, I. Costin and M. Olivetti, "Improving the performance of a two way control valve using a 3D CFD modelling", ASME International Mechanical Engineering Congress and Exposition, Nov. 14-20, 2014, Montreal, Canada. DOI 10.1115/IMECE2014-3820.
10. E. Frosina, D. Buono, A. Senatore and I. Costin, "A Simulation Methodology Applied on Hydraulic Valves for High Fluxes", *International Review on Modelling and Simulations* 9(3): 217, 2016. DOI: 10.15866/iremos.v9i3.9612.
11. F. Pintore, M. Borghi, R. Morselli, A. Benevelli, B. Zardin and F. Belluzzi, "Modelling and Simulation of the Hydraulic Circuit of an Agricultural Tractor", ASME 8th FPNI Ph.D Symposium on Fluid Power, June 11–13, 2014, Lappeenranta, Finland. DOI: 10.1115/FPNI2014-7848.
12. M. Borghi, B. Zardin, F. Pintore and F. Belluzzi, "Energy savings in the hydraulic circuit of agricultural tractors", *Energy Procedia* 45: 352-361, 2014. DOI: 10.1016/j.egypro.2014.01.038.
13. H.C. Pedersen, T.O. Andersen, R.H. Hansen and S. Stubkier, "Investigation of Separate Meter-In Separate Meter-Out Control Strategies for Systems with Over Centre Valves", Proceedings of the BATH/ASME 2010 Symposium on Fluid Power & Motion Control, September 15-17, 2010, Bath, United Kingdom.
14. S. Nordås, M.K. Ebbesen and T.O. Andersen, "Feasibility study of a digital hydraulic winch drive system", The Ninth Workshop on Digital Fluid Power, September 7-8, 2017, Aalborg, Denmark.
15. L. Gilardino, "Test rig for experimental investigations on motion control valves", ASME 8th Biennial Conference on Engineering Systems Design and Analysis, Torino, Italy, July 4-7, 2006. DOI: 10.1115/ESDA2006-95804.
16. A. Corvaglia, G. Altare, R. Finesso and M. Rundo, "Computational fluid dynamics modelling of a load sensing proportional valve", Proceedings of the ASME-JSME-KSME 2019 Joint Fluids Engineering Conference, July 28-August 1, 2019, San Francisco, USA.