

Improved Stochastic Macromodeling of Electrical Circuits via Rational Polynomial Chaos Expansions

Original

Improved Stochastic Macromodeling of Electrical Circuits via Rational Polynomial Chaos Expansions / Manfredi, P., Grivet-Talocia, S. - ELETTRONICO. - (2019), pp. 511-514. (2019 Joint International Symposium on Electromagnetic Compatibility, Sapporo and Asia-Pacific International Symposium on Electromagnetic Compatibility, EMC Sapporo/APEMC 2019 Giappone 2019) [10.23919/EMCTokyo.2019.8893744].

Availability:

This version is available at: 11583/2773005 since: 2019-12-11T15:30:25Z

Publisher:

Institute of Electrical and Electronics Engineers Inc.

Published

DOI:10.23919/EMCTokyo.2019.8893744

Terms of use:

This article is made available under terms and conditions as specified in the corresponding bibliographic description in the repository

Publisher copyright

(Article begins on next page)

Improved Stochastic Macromodeling of Electrical Circuits via Rational Polynomial Chaos Expansions

Paolo Manfredi and Stefano Grivet-Talocia
Department of Electronics and Telecommunications
Politecnico di Torino, Turin, Italy 10129
Email: paolo.manfredi@polito.it

Abstract—This paper introduces the use of a rational polynomial chaos expansions (PCE) for the stochastic macromodeling of network responses affected by parameter variability, as a more suitable alternative to classical PCEs. The new formulation is motivated by the intrinsic form of the response of a linear and lumped network, which is indeed known to be a rational function of both frequency and parameters. As a matter of fact, the proposed representation is exact for lumped circuits, provided that a suitable expansion order and truncation is used. Moreover, it is shown that the rational PCE provides a better approximation also for distributed networks. An iterative and re-weighted linear least-square regression is used to estimate the model coefficients. It is also found that their calculation is less sensitive to the number of regression samples, compared to the classical PCE. Two application examples, concerning a lumped and a distributed system, illustrate and validate the advocated methodology.

Index Terms—Multiport systems, polynomial chaos, rational modeling, variability analysis, uncertainty quantification.

I. INTRODUCTION

Polynomial chaos expansion (PCE) recently gained wide popularity in the variability analysis of electrical and electronic systems because of its higher computational efficiency over Monte Carlo sampling or other non-stochastic macromodeling techniques [1]–[3]. In this framework, any stochastic quantity of interest is represented as an expansion of orthogonal polynomial functions of the random parameters affecting the system, which provides fast convergence of statistical moments. Traditionally, a single PCE is used, and the model coefficients are computed by either projection [4], [5], interpolation [6], [7], or regression [8], [9] (see [1], [2] for comparisons between these classes of approaches).

In other domains, Padé approximants (i.e., rational functions) were proposed for the PCE formalism because of their improved accuracy in the modeling of discontinuous functions [10]–[12]. Indeed, the response of a linear and lumped electrical network (e.g., in impedance, admittance, or scattering representation) is known to be a rational function of both frequency and parameters. Therefore, a rational PCE can model exactly the response of any circuit belonging to this class, provided that suitable order and truncation are used.

Following the above consideration, this paper introduces rational PCEs for the stochastic modeling of electrical network responses, leading to the new paradigm of rational polynomial chaos (RPC). However, compared to [10]–[12], a different strategy is used for the PCE truncation, the calculation of

the model coefficients, and bias correction, as discussed in the following. Furthermore, it is also shown that the proposed rational stochastic models turn out to be more accurate also for the important case of distributed networks that include delay elements, such as transmission lines.

Two numerical examples that consider a lumped and a distributed network illustrate and validate the proposed methodology, showing that the novel RPC model provides better accuracy than the classical PCE. Moreover, it is shown that the model coefficients are less sensitive to the number of regression samples used for their computation.

II. NON-STOCHASTIC MACROMODELING APPROACHES

The proposed model representation turns out to be closely related to the so-called parameterized Sanathanan-Koerner (PSK) form [13], which is commonly used for describing behavioral models whose response depends on frequency and on additional *deterministic* parameters. As in the proposed RPC (see below), the PSK form expands numerator and denominator of the model response into a set of frequency-domain and parameter-domain basis functions. The former are usually partial fractions, whereas the latter can be orthogonal [14] or trigonometric polynomials [15], or any other set of basis functions that provide the desired approximation properties over frequency and parameter ranges. Similar rational forms are ubiquitous also in other domains such as model order reduction (MOR) [16], where interpolation-based methods like the Loewner framework [17], [18], and its parameterized version [19], adopt a barycentric rational structure of the model. Even the widespread vector fitting (VF) scheme [20] is based on such a model structure. These premises confirm that rational expansions have been widely proven to be superior, under many aspects, with respect to simpler polynomial expansions.

Non-stochastic parameterized macromodeling based on the PSK representation aims at reproducing in closed form the true system response through a compact and fast-to-simulate model, with the main objective of performing model-based optimization and design centering. The present work considers the parameters as stochastic variables and uses a rational PCE to characterize the induced distributions and related moments of the system responses, with the main objective of robust design under stochastic conditions and uncertainty quantification. The proposed iterative re-weighted regression

for estimating model coefficients can be seen as an application of the PSK iteration, as described in [13], see also [21].

III. VARIABILITY ANALYSIS OF MULTIPORT SYSTEMS

According to the standard framework [8], any stochastic frequency-domain response S of a linear electrical system that is affected by d random parameters $\boldsymbol{\theta} = [\theta_1, \dots, \theta_d]$ is expressed as the following PCE:

$$S(s, \boldsymbol{\theta}) \approx \sum_{\ell=1}^L S_{\ell}(s) \varphi_{\ell}(\boldsymbol{\theta}), \quad (1)$$

where $\{\varphi_{\ell}(\boldsymbol{\theta})\}_{\ell=1}^L$ are multivariate polynomial functions that are orthonormal based on the joint distribution of the random parameters $\boldsymbol{\theta}$, and S_{ℓ} are pertinent model coefficients. The basis functions are constructed as the product of univariate polynomials, i.e.,

$$\varphi_{\ell}(\boldsymbol{\theta}) = \phi_{k_{\ell,1}}(\theta_1) \cdots \phi_{k_{\ell,d}}(\theta_d), \quad (2)$$

with $\phi_{k_{\ell,i}}(\theta_i)$ being a polynomial of degree $k_{\ell,i}$. The coefficients S_{ℓ} are usually obtained by linear least-square regression, starting from a set of responses computed for random realizations of the random parameters $\boldsymbol{\theta}$.

Typically, a *total degree* truncation is adopted, meaning that only the multivariate polynomials with degrees summing up to p at most are retained (i.e., $\sum_{i=1}^d k_{\ell,i} \leq p, \forall \ell$), leading to a number of terms $L = (p+d)!/(p!d!)$. The regression problem needs to be overdetermined, and a number of samples M that is twice the number of expansion terms (i.e., $M = 2L$) is often recommended. However, as shown later in this paper, the accuracy is highly dependent on the sample size, especially at high frequency.

IV. RATIONAL POLYNOMIAL CHAOS EXPANSION

Despite the common practice of modeling network responses using a single PCE like (1), it is argued that the form of network parameters for lumped circuits is rational in both frequency and parameters, with the latter never appearing with degree higher than one.

A formal proof is deferred to a future report. As a trivial, yet illustrative example, consider the equivalent impedance of a parallel RLC circuit in the Laplace domain:

$$Z_{eq}(s, \boldsymbol{\theta}) = \frac{1}{\frac{1}{R} + \frac{1}{sL} + sC} = \frac{sRC}{R + sL + s^2RLC} \quad (3)$$

with $\boldsymbol{\theta} = [R, L, C]$ and where, indeed, each element value appears up to linearly in both the numerator and denominator. If a PCE in the form of (1) is used to model the variability of $Z_{eq}(s)$ due to stochastic variations of R, L , and C , it would be unavoidably inexact.

Instead, a ratio of PCEs:

$$S(s, \boldsymbol{\theta}) = \frac{\sum_{\ell=1}^L N_{\ell}(s) \varphi_{\ell}(\boldsymbol{\theta})}{\sum_{\ell=1}^L D_{\ell}(s) \varphi_{\ell}(\boldsymbol{\theta})} \quad (4)$$

can provide an exact model, provided that all *multi-linear* terms in (3) are included in the basis functions φ_{ℓ} . Table I

shows the maximum degree with which the three RLC parameters appear in each basis function with two different truncation strategies, i.e., the total degree truncation discussed in Section III, and the less common tensor product truncation, which retains every basis function with univariate degree $k_{\ell,i} \leq p, \forall \ell, \forall i = 1, \dots, d$, leading to $L = (p+1)^d$ terms. The only term appearing at the numerator (linear in R and C) is highlighted with a red box, whereas the three terms appearing in the denominator (linear in R , in L , and in R, L, C simultaneously) are highlighted in blue. It is noted that the classical total degree truncation contains higher order terms that are never expected to appear in the response, and requires a large order (in general, $p = d$) to capture all terms. On the contrary, a tensor product truncation with $p = 1$ already contains all necessary terms, thus resulting in a more compact and optimized expansion. Owing to the above consideration, a tensor product truncation is adopted here, as opposed to common-practice PCE implementations that mostly use total degree truncation. As shown in the next section, this model (exact for lumped networks) turns out to be more accurate (albeit approximate) also for distributed systems, but a higher order could be required to improve accuracy.

TABLE I
MAXIMUM DEGREE OF THE PARAMETERS R, L , AND C IN EACH BASIS FUNCTION WITH TOTAL DEGREE AND TENSOR PRODUCT TRUNCATION.

function	total degree				tensor product			
	order	degree			order	degree		
ℓ	p	$k_{\ell,1}$ (R)	$k_{\ell,2}$ (L)	$k_{\ell,3}$ (C)	p	$k_{\ell,1}$ (R)	$k_{\ell,2}$ (L)	$k_{\ell,3}$ (C)
1	0	0	0	0	0	0	0	0
2	1	1	0	0	1	1	0	0
3		0	1	0		0	1	0
4		0	0	1		1	1	0
5	2	2	0	0		0	0	1
6		1	1	0		1	0	1
7		1	0	1		0	1	1
8		0	2	0		1	1	1
9		0	1	1				
10		0	0	2				
11	3	3	0	0				
12		2	1	0				
13		2	0	1				
14		1	2	0				
15		1	1	1				
16		1	0	2				
17		0	3	0				
18		0	2	1				
19		0	1	2				
20		0	0	3				

Since (4) is nonlinear in the denominator coefficients D_{ℓ} , linear regression cannot be directly used to estimate the coefficients. In [10]–[12], a multidimensional quadrature rule is used to calculate the coefficients, but its generalization to high dimensions is non-trivial. An alternative approach is

proposed in this paper. The model is rearranged by multiplying by the denominator, leading to

$$\sum_{\ell=1}^L N_{\ell}(s)\varphi_{\ell}(\boldsymbol{\theta}) - S(s, \boldsymbol{\theta}) \sum_{\ell=2}^L D_{\ell}(s)\varphi_{\ell}(\boldsymbol{\theta}) \approx S(s, \boldsymbol{\theta}), \quad (5)$$

where D_1 has been set to unity to remove indeterminacy. The new equation (5) is now linear in the coefficients and can be solved by means of standard linear regression to find the remaining $2L - 1$ unknown coefficients. However, the above rearrangement introduces a bias in the coefficients. Differently from [10], in this paper the bias is *systematically* eliminated through iterative re-weighting [21]. This iterative regression problem is solved at each frequency point separately.

V. NUMERICAL RESULTS

As an example of a lumped-component circuit, the first application test case deals with the seventh-order Chebyshev low-pass filter whose schematic is depicted in Fig. 1. The filter is designed to have a cut-off frequency of 2 GHz and a passband ripple of 0.5 dB. The components values indicated in Fig. 1 are available on the market and are close to the optimal design values. The tolerances are taken from the datasheets provided by the vendor, and they are considered as the standard deviation of seven independent Gaussian random variables describing the variability of the component values.

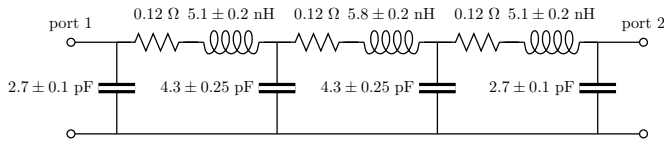

Fig. 1. Schematic of the seventh-order Chebyshev low-pass filter.

Fig. 2 shows the resulting variability of the magnitude of the insertion loss S_{21} . The gray lines are a subset of MC samples. The colored lines indicate the mean and standard deviation of S_{21} . The blue lines are the estimations obtained with a MC analysis. Starting from an initial value of 125, the number of MC samples is doubled until the maximum relative difference of the standard deviation over the frequency is less than 1%, which resulted in 16000 samples to be considered. The dotted and dashed red lines are the results obtained with classical PC expansions of total degree $p = 2$ and $p = 3$, respectively. Also in this case, the number of samples for the regression is doubled until the difference of the standard deviation is below 1%, starting from an initial value of $M = L$. The total number of regression samples is thus 2304 for $p = 2$ and 1920 for $p = 3$. Finally, the dotted-dashed green lines are the result obtained with a first-order RPC model. Owing to the exactness of the model, there is no need to oversample the regression problem, and $M = 2L - 1 = 255$ samples are sufficient. For this lumped circuit, the iterative re-weighting converges in one step. For this example, it is possible to conclude that, besides being more accurate (actually, exact), the proposed RPC is

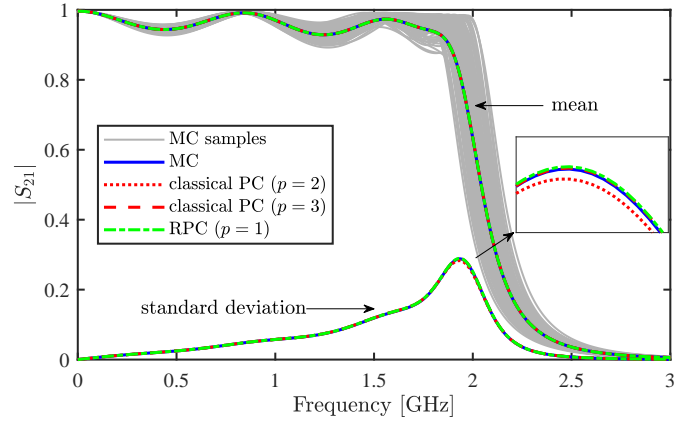

Fig. 2. Variability of the insertion loss of the Chebyshev filter.

about $63\times$ more efficient than MC, and at least $7.5\times$ faster than the classical PC.

The close-up around the standard deviation peak allows concluding that the second-order classical PC expansion is not accurate enough, even at convergence of the regression. The maximum relative error w.r.t. the MC result is 1.9%. The third-order expansion and the RPC model are accurate within the convergence criterion adopted for the MC analysis (0.6% and 0.4%, respectively). It should be noted that the residual difference between the RPC and the MC results is due to the finite precision of the MC estimate itself, and not to a modeling error. A cross-validation in which the same parameter values as used for the MC analysis are also used to sample the RPC model (results not shown here) confirms the above conclusion.

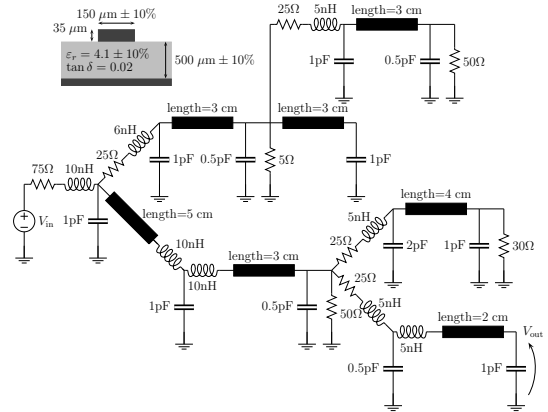

Fig. 3. Schematic of the microstrip transmission line network.

The second validation example concerns the analysis of a distributed circuit, i.e., the network of Fig. 3. The circuit includes delay elements, namely seven microstrip transmission lines having the cross-section shown in the top left corner. The variability is due to the line width, substrate thickness, and substrate relative permittivity, which are assumed to be three independent Gaussian random variables with a standard deviation of 10%.

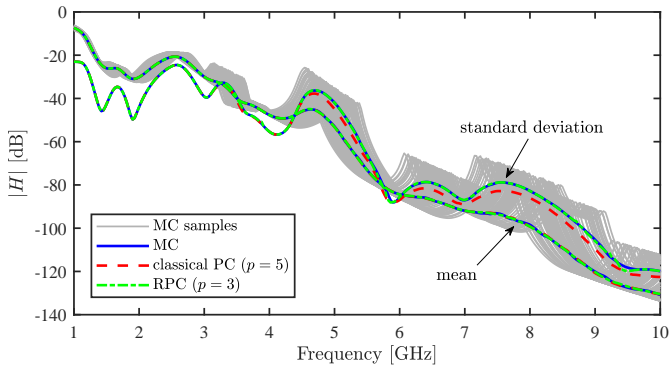

Fig. 4. Variability of the transfer function $H(s)$ in the network of Fig. 3.

Fig. 4 shows the high-frequency stochastic behavior of the transfer function $H(s) = V_{\text{out}}(s)/V_{\text{in}}(s)$. As in the previous example, the gray lines are a subset of samples from the MC analysis. The solid blue lines are the mean and standard deviation of the MC samples. The dashed red lines are the same statistical quantities estimated with a classical PC expansion of total degree $p = 5$ (56 terms). The calculation of the PC expansion coefficients required 14336 samples for the regression to reach the 1% convergence criterion. Despite the high order and the enormous number of regression samples used, the error on the standard deviation is still significantly large, with a maximum relative error of 4.1% w.r.t. the reference MC result. Finally, the dotted-dashed green lines are the results obtained with an RPC model of tensor degree $p = 3$ (127 terms). The model coefficients are estimated with 2032 regression samples only, thus highlighting a more rapid convergence of the regression problem for the RPC case. A much better accuracy over the classical PC model can be appreciated. The maximum relative error on the standard deviation w.r.t. MC is 0.6%, well below the 1% precision of the MC result itself.

VI. CONCLUSIONS

This paper presented a novel RPC modeling paradigm for the stochastic responses of linear electrical networks. The new approach uses a ratio of PC expansions with tensor product truncation rather than a standard polynomial expansion with total degree truncation. A very interesting feature of the proposed framework is that a first-order RPC model is provably exact for any lumped network parameterized by its component values. In addition, due to the well-known superiority of Padé rational approximants with respect to standard polynomial approximations or interpolations, it is expected that the proposed method leads to far superior accuracy in uncertainty quantification than standard PCE. The two application examples analyzed in this work demonstrated that the novel RPC model provides indeed a better accuracy, and moreover its coefficients are less sensitive to the number of regression samples used in the model generation.

REFERENCES

- [1] J. Bai, G. Zhang, D. Wang, A. P. Duffy and L. Wang, "Performance comparison of the SGM and the SCM in EMC Simulation," *IEEE Trans. Electromagn. Compat.*, vol. 58, no. 6, pp. 1739–1746, Dec. 2016.
- [2] P. Manfredi, D. Vande Ginste, I. S. Stievano, D. De Zutter, and F. G. Canavero, "Stochastic transmission line analysis via polynomial chaos methods: an overview," *IEEE Electromagn. Compat. Mag.*, vol. 6, no. 3, pp. 77–84, 2017.
- [3] A. Kaintura, T. Dhaene, and D. Spina, "Review of polynomial chaos-based methods for uncertainty quantification in modern integrated circuits," *Electronics*, vol. 7, no. 3, p. 30:1–21, Feb. 2018.
- [4] I. S. Stievano, P. Manfredi, and F. G. Canavero, "Stochastic analysis of multiconductor cables and interconnects," *IEEE Trans. Electromagn. Compat.*, vol. 53, no. 2, pp. 501–507, May 2011.
- [5] M. R. Rufuie, E. Gad, M. Nakhla, and R. Achar, "Generalized Hermite polynomial chaos for variability analysis of macromodels embedded in nonlinear circuits," *IEEE Trans. Compon. Packag. Manuf. Technol.*, vol. 4, no. 4, pp. 673–684, Apr. 2014.
- [6] J. S. Ochoa and A. C. Cangellaris, "Random-space dimensionality reduction for expedient yield estimation of passive microwave structures," *IEEE Trans. Microw. Theory Tech.*, vol. 61, no. 12, pp. 4313–4321, Dec. 2013.
- [7] P. Manfredi, D. Vande Ginste, D. De Zutter, and F. G. Canavero, "Generalized decoupled polynomial chaos for nonlinear circuits with many random parameters," *IEEE Microw. Wireless Compon. Lett.*, vol. 25, no. 8, pp. 505–507, Aug. 2015.
- [8] D. Spina, F. Ferranti, T. Dhaene, L. Knockaert, G. Antonini, and D. Vande Ginste, "Variability analysis of multiport systems via polynomial-chaos expansion," *IEEE Trans. Microw. Theory Tech.*, vol. 60, no. 8, pp. 2329–2338, Aug. 2012.
- [9] A. K. Prasad and S. Roy, "Accurate reduced dimensional polynomial chaos for efficient uncertainty quantification of microwave/RF networks," *IEEE Trans. Microw. Theory Tech.*, vol. 65, no. 10, pp. 3697–3708, Oct. 2017.
- [10] T. Chantrasm, A. Doostan, and G. Iaccarino, "Padé-Legendre approximants for uncertainty analysis with discontinuous response surfaces," *J. Computational Physics*, vol. 228, no. 19, pp. 7159–7180, Oct. 2009.
- [11] E. Jacquelin, O. Dessombz, J.-J. Sinou, A. Adhikari, and M. I. Friswell, "Polynomial chaos-based Padé expansion in structural dynamics," *Int. J. Numerical Methods Eng.*, vol. 111, no. 12, pp. 1170–1191, Sep. 2017.
- [12] M. Rossi, S. Agneessens, H. Rogier, D. Vande Ginste, "Stochastic analysis of the impact of substrate compression on the performance of textile antennas," *IEEE Trans. Antennas Propag.*, vol. 64, no. 6, pp. 2507–2512, Jun. 2016.
- [13] P. Triverio, S. Grivet-Talocia, and M. S. Nakhla, "A parameterized macromodeling strategy with uniform stability test," *IEEE Trans. Adv. Packag.*, vol. 32, no. 1, pp. 205–215, Feb. 2009.
- [14] S. Grivet-Talocia and R. Trinchero, "Behavioral, parameterized, and broadband modeling of wired interconnects with internal discontinuities," *IEEE Trans. Electromagn. Compat.*, vol. 60, no. 1, pp. 77–85, 2018.
- [15] S. Grivet-Talocia and E. Fevola, "Compact parameterized black-box modeling via Fourier-rational approximations," *IEEE Trans. Electromagn. Compat.*, vol. 59, no. 4, pp. 1133–1142, 2017.
- [16] P. Benner, A. Cohen, M. Ohlberger, and K. Willcox. *Model Reduction and Approximation: Theory and Algorithms*. SIAM Publications, Philadelphia, PA, 2017.
- [17] A. J. Mayo and A. C. Antoulas, "A framework for the solution of the generalized realization problem," *Linear algebra and its applications*, vol. 425, no. 2-3, pp. 634–662, 2007.
- [18] S. Lefteriu and A. C. Antoulas, "A new approach to modeling multiport systems from frequency-domain data," *IEEE Trans. Comput.-Aided Des. Integr. Circuits Syst.*, vol. 29, no. 1, pp. 14–27, Jan. 2010.
- [19] A. Ionita and A. Antoulas, "Data-driven parametrized model reduction in the Loewner framework," *SIAM J. Sci. Comput.*, vol. 36, no. 3, pp. A984–A1007, 2014.
- [20] B. Gustavsen and A. Semlyen, "Rational approximation of frequency domain responses by vector fitting," *IEEE Trans. Power Del.*, vol. 14, no. 3, pp. 1052–1061, Jul. 1999.
- [21] C. K. Sanathanan and J. Koerner, "Transfer function synthesis as a ratio of two complex polynomials," *IEEE Trans. Autom. Control*, vol. 8, no. 1, pp. 56–58, Jan. 1963.