

Use of a large triaxial cell for testing conditioned soil for EPBS tunnelling

Original

Use of a large triaxial cell for testing conditioned soil for EPBS tunnelling / Martinelli, D.; Todaro, C.; Luciani, A.; Peila, D..
- In: TUNNELLING AND UNDERGROUND SPACE TECHNOLOGY. - ISSN 0886-7798. - STAMPA. - 94:(2019), pp. 103-126. [10.1016/j.tust.2019.103126]

Availability:

This version is available at: 11583/2773002 since: 2021-04-03T08:51:56Z

Publisher:

Elsevier

Published

DOI:10.1016/j.tust.2019.103126

Terms of use:

This article is made available under terms and conditions as specified in the corresponding bibliographic description in the repository

Publisher copyright

Elsevier postprint/Author's Accepted Manuscript

© 2019. This manuscript version is made available under the CC-BY-NC-ND 4.0 license
<http://creativecommons.org/licenses/by-nc-nd/4.0/>. The final authenticated version is available online at:
<http://dx.doi.org/10.1016/j.tust.2019.103126>

(Article begins on next page)

Use of a large triaxial cell for testing conditioned soil for EPBS tunnelling

D. Martinelli, C. Todaro, A. Luciani, D. Peila

DIATI-Politecnico di Torino, Corso Duca degli Abruzzi 24, 10129 Torino, Italy

Abstract

Laboratory testing of soil conditioning for EPB tunnelling is a common procedure to assess the suitability of the conditioning itself in different tunnel projects, but normally the stress influence is not taken into account. This work describes the behaviour of two different conditioned masses in different stress conditions through a large diameter triaxial cell, which allows to reproduce different stress scenarios. The results obtained show the influence of the stress on the shear strength of the conditioned material and the different attitude of behaving as a fluid testing a granular material and a more heterogeneous one. Also the two material behaved differently as the presence of a more relevant fine part in the conditioned mass allows the material to maintain its fluidity also at higher pressures.

Keywords: EPB, Soil Conditioning, Triaxial Testing, Shear Strength

1. Introduction

2 The use of EPB shield technology for the construction of tunnels in urban
3 areas, is more and more taking a relevant role among the excavation methods
4 in such conditions. This is due to the fact that it allows to proceed safely
5 and effectively in several challenging conditions, such as heavily heterogenous

Preprint submitted to Tunnelling and Underground Space Technology September 10, 2019

6 geologies, low overburdens in densely populated areas and relevant water table
7 levels. Moreover EPB shields are not requiring large spaces at the tunnel
8 entrance such in the case of slurry shields, which need complex and extended
9 infrastructures (Herrenknecht, 1994; Maidl and Hintz, 2003; Lovat, 2006;
10 Peila, 2009; Thewes, 2014). In addition, the improvement of this technology
11 throughout the ages allowed the extension of the range of applicability of EPB
12 shields almost to any excavation medium, from clay to rock masses (Mair
13 et al., 2003; Merritt et al., 2003; Milligan, 2000; Thewes, 2007; Vinai et al.,
14 2007; Thewes et al., 2010; Zumsteg et al., 2013a,b; Peila, 2014; Martinelli
15 et al., 2015b; Peila et al., 2016; Martinelli et al., 2015a), and its use with
16 higher counterpressures that today reach values over 6 bars. This is also due
17 to the intense development of the agents used for the conditioning process,
18 such as foams, polymers and fillers. This paper is specifically focused on
19 cohesionless soils.

20 One important issue regarding the study of the conditioned soil is to un-
21 derstand its mechanical behaviour when the mass is stressed by an external
22 pressure. This aspect is crucial to assess the suitability of a conditioned
23 mass during an excavation. The mass has to be fluid enough to flow into
24 the excavating chamber through the cutterhead openings and to apply effec-
25 tively the counterpressure to the front, but maintaining a workability pulpy
26 enough to be extracted through the screw conveyor. The second aspect can
27 be efficaciously studied by mean of tests such as slump test, which can give
28 good indications on the workability of the conditioned mass (Bezuijen et al.,
29 2005; Vinai et al., 2008; Peila et al., 2009; Budach and Thewes, 2010; Thewes
30 et al., 2012; Galli and Thewes, 2016). On the contrary the first aspect is a

31 bit more difficult to be assessed with standard tests, as no clear indications
32 on the pressure transmissivity can be studied. This is a key aspect for the
33 present work, and this new testing approach is an attempt to investigate
34 it. An important study on this issue has been already carried out by Mori
35 et al. (2015), Mooney et al. (2016) and Mori et al. (2018): their researches
36 illustrate how pressure influences conditioned soil behaviour and how at-
37 mospheric test results must be viewed in the context of expected chamber
38 pressures taking into account, through digital image analysis, the influence of
39 pressure on bubble-soil interaction (including with time). The study is aimed
40 to assess the compressibility, shear strength, and abrasivity of conditioned
41 soil under pressure explained in terms of density, soil and air compressibil-
42 ity and porosity. Similar approach has been preliminarily investigated by
43 Psomas (2001) by characterizing the coupling foam/sand mixture under dif-
44 ferent stress conditions and by Yang et al. (2018) who has considered also
45 the chemical influence of polymers.

46 In order to proceed with this study, it is necessary to imagine a model of
47 the problem to be studied. In an EPB tunnelling project in soil, the material
48 is first excavated, mixed with a conditioning agent (usually water and foam)
49 and then strained with an external stress. In the excavating chamber this
50 stress is represented by the compression of the conditioned material with
51 other material up to the needed counterpressure. The stress should be ideally
52 hydrostatic, that is the reason why the conditioning has to bring to the mass
53 sufficient fluidity.

54 The best way to represent in laboratory such a situation is to apply a
55 confinement to the conditioned mass, in order to reproduce the excavating

56 chamber as a cylindrical pressurized tank with one of the bases which repre-
57 sent the cutterhead and thus which can be able to move and virtually apply a
58 distributed pressure. Of course the most suitable material to apply the pres-
59 sure in this condition is a fluid like the water, because by definition when a
60 pressure is applied on this, it is transmitted immediately in all the directions
61 hydrostatically. On the contrary a soil is not able to transmit the pressure
62 in such a way, for example in a natural deposit close to the surface the ver-
63 tical stress is given usually by the weight of the soil itself, but the horizontal
64 resulting stress is usually lower and is function of the friction angle φ . Con-
65 sidering a normally consolidated granular deposit, the at rest lateral earth
66 pressure coefficient K_0 , linking the vertical and horizontal in-situ stress, is
67 equal to (Jaky, 1948):

$$K_0 = 1 - \sin \varphi' \quad (1)$$

68 As clearly achievable from the Equation 1, in order to obtain the hydro-
69 static condition and therefore a K_0 equal to 1, the effective angle of friction
70 must be equal to 0° . This drop of friction angle can be obtained by mixing
71 conditioning agents with the cohesionless mass.

72 In order to establish the true mechanical behaviour of the soil after con-
73 ditioning, it is crucial to maintain the foam and the liquid trapped inside the
74 mass, otherwise the actual behaviour cannot be established. By applying
75 the pressure without a confinement, for instance a piston in a tank which is
76 not completely sealed, a substantial fluid loss (water and foaming agent) can
77 be observed. This will cause a wrong assessment of the actual mechanical
78 behaviour of the mass, as the intergranular voids will loose the presence of
79 the bubbles and the trend will be to have less space between the grains.

80 The aim of this work is to study the behaviour of the conditioned soil
81 under pressure with a standard common geotechnical test such as the triaxial
82 test, even though carried out in particular conditions. For this study a large
83 cell has been used to assess the shear strength of the material depending on
84 the pressure conditions.

85 **2. Importance of pressure on soil conditioning**

86 In order to avoid this fluid loss in the conditioned mass to keep the mate-
87 rial as in the bulk chamber, the best solution would be to seal all the possible
88 gaps where the liquid might flow away. For this reason, the situation that
89 has to be studied is similar to the undrained condition usually considered
90 in geotechnics while performing triaxial tests. In that case the water in the
91 intergranular voids, which is produced by the external pressurization when
92 the sample is saturated, is creating a pore pressure. In general in geotechnics
93 the definition of undrained condition is directly linked to the pore pressure,
94 and this condition is encountered when the rate of loading is highly rela-
95 tive to the soil hydraulic conductivity, so that water cannot escape from the
96 pores during loading (Lancellotta, 2009). This condition, performing a tri-
97 axial test, indicates the circumstance in which a soil element (i.e. locally)
98 cannot exchange water mass with the surrounding ambient. If the soil is sat-
99 urated and both particles and water are assumed to be incompressible, the
100 above definition means that the undrained condition is a constant volume
101 condition. Because of this constraint, an excess pore pressure develops and
102 increments of effective and total stresses do not coincide.

103 Considering the above mentioned definitions, it is immediately clear that

104 the undrained condition used for testing conditioned soils cannot strictly co-
105 incide with the geotechnical one. This is mainly due to the fact that the
106 conditioned sample is not saturated with water: it is usually in a condition
107 close to the saturation but most of the pores are filled with foam bubbles
108 which can change size depending on the acting pressure. In this scenario
109 it is thus clear that compared to a sample saturated with water, the condi-
110 tioned sample is compressible, therefore the constant volume condition is not
111 fulfilled. The saturation of the conditioned sample with water and foam is
112 crucial in order to transmit effectively the pressure. If this is not happening,
113 the material once compressed does not immediately transfer the pressure in
114 all the directions, as the fluids are first absorbed by the drier mass. Thus
115 the condition we are considering for testing the conditioned samples is just
116 partially equal to the undrained condition used in geotechnics; in the samples
117 studied in this research the medium is compressible and the pore pressures
118 develop from a mixture of water, foaming agent and mostly air.

119 The mechanical behaviour of the conditioned material in certain pressure
120 conditions is not fully clear: those pressures which are acting on the material
121 are according to Terzaghi's theory. The theory states that the stress in any
122 point of a section through a mass of soil can be computed from the total
123 principal stresses σ_1 , σ_2 and σ_3 which act at this point. The balance $\sigma'_1 =$
124 $\sigma_1 - u$, $\sigma'_2 = \sigma_2 - u$ and $\sigma'_3 = \sigma_3 - u$ (effective principal stresses) represents an
125 excess over the neutral stress u (pore pressure) and it has its seat exclusively
126 in the solid phase of the soil. The theory of the effective pressure in EPB
127 tunnelling has been treated especially by Anagnostou and Kovári (1996),
128 where a distinction is given between fluid-pressure and effective pressure in

129 the chamber. In this case, the effective pressure can be visualized as a grain
130 to grain contact pressure between the muck and the ground at the face.
131 The water pressure in the chamber reduces the hydraulic head gradient in
132 the ground and, consequently, the seepage forces acting in front of the face.
133 Considering the front stability, the face is thus stabilized both by direct
134 support of the pressurized muck and by the reduction of the seepage forces
135 in the ground. The difficult point which has to be better studied, and that
136 is object of this research work, is the influence and the contribution of the
137 foam bubbles inside this theory.

138 In EPB tunnelling, the material is usually conditioned under a certain
139 stress condition, which is not zero. Thus the study of the conditioned soil
140 should be carried out under particular pressure conditions which are proper
141 to the excavating chamber in operation. This issue is quite complex to be
142 taken into account: in laboratory the addition of foam and other conditioning
143 agents is usually conducted at room conditions, and the representation of the
144 pressurized status is difficult to be considered.

145 The main aspect in this case is to verify the behaviour of the conditioned
146 material in different pressure conditions: if in one side the slump test is
147 generally giving a good answer and response on the quality of the conditioned
148 soil for EPB applications, on the other hand it cannot give indications on its
149 behaviour under particular stress conditions. This is a crucial issue, especially
150 considering that a key parameter of the conditioning is the FER, which is
151 representing the expansion ratio and which is strictly linked to the pressure.
152 Considering that the conditioned soil is a multiphase medium, composed of
153 different material with different compressibilities, its characterization is quite

154 difficult.

155 In this context new testing procedures would solve this important issue.
156 Theoretically, the application of the stress on the conditioned mass would
157 cause a large deformation in the first phase, as the bubbles of the foam
158 are the first to be strained due to the higher compressibility of the air; in
159 the second phase, once the intergranular voids between the grains are small
160 enough to allow again the contact of the soil (as it usually happens in the
161 natural soil), the deformability is different and also the stress application
162 behaviour of the soil itself. In this second stage it is normal to think that the
163 deformability of the medium will decrease and the hydrostatic transmission
164 of the pressure would be much more difficult. Figure 1 shows the mechanics
165 of the conditioned mass when the pressure is applied: at room pressure the
166 grains are not in contact (Figure 1a), after the application of the pressure
167 the grains are moving closer when the bubbles are deforming much more
168 compared to the soil (Figure 1b).

169 This consideration explains why this study is crucial in the future labora-
170 tory testing procedure, as the rigidity of the conditioned spoil is dependent
171 on the stress. A material that is too stiff in the excavating chamber can cause
172 an increase of torque and temperature, with possible faults and severe dam-
173 ages to the machine. This aspect, as already mentioned in the introduction,
174 has been investigated by Mori et al. (2015), Mooney et al. (2016) and Mori
175 et al. (2018).

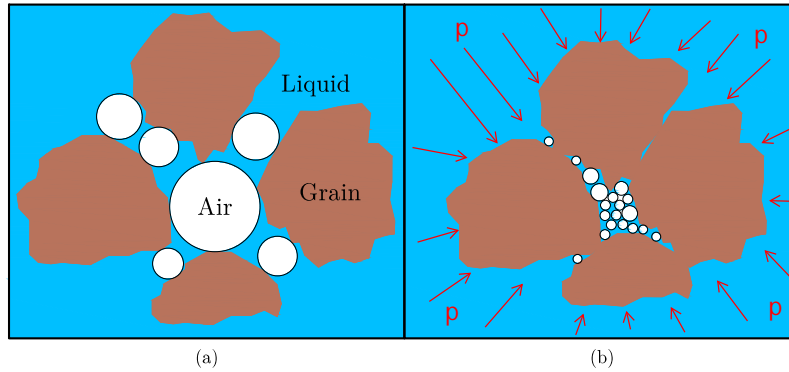

Figure 1: Conditioned mass before (a) and after (b) the pressure application (represented by the red arrows). The soil grains in this model can be considered as non-deformable compared to the air.

176 3. Modified large diameter triaxial test

177 In order to study the conditioned material and fulfilling the new approach
 178 on testing this type of material, the use of the triaxial test has been considered
 179 for assessing the behaviour of the material and for studying the apparent
 180 transition from a fluid material to a rigid one.

181 For this type of testing, it is essential to reduce any external disturbance
 182 and create an homogeneous sample: for this purpose, a large triaxial cell
 183 should be used. This type of equipment has also another advantage; the
 184 sample is large enough to be separately tested in a slump cone at the begin-
 185 ning and at the end of the triaxial test.

186 3.1. Apparatus

187 The apparatus used for this research (Figure 2) had been initially de-
 188 signed for testing undisturbed and disturbed samples of coarse soils, such as

189 gravel and cobbles. The original design included the possibility of testing
190 loose soils and cores of undisturbed samples obtained by using the freezing
191 technique. The apparatus used has been designed by the staff of the geotech-
192 nical laboratory of the Department of Structural, Geotechnical and Building
193 Engineering of Politecnico di Torino and the original design details have been
194 introduced by Fiorio (2003).

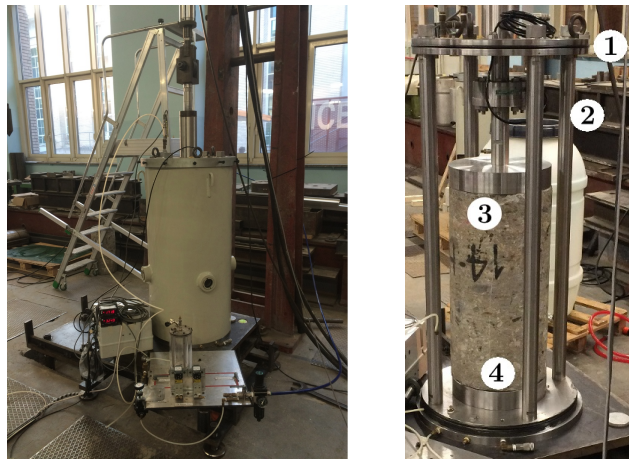

Figure 2: Large diameter triaxial cell apparatus used for the research with its main internal parts: 1) top plate, 2) steel bar, 3) top cap, 4) bottom cap (Martinelli, 2016).

195 The cell is composed of a bottom cap (number 4 in Figure 2) of 300
196 mm in diameter, which allows to accommodate samples 600 mm high. The
197 sample is placed on the bottom stainless steel cap (number 3 in Figure 2)
198 with the same diameter as the sample and with a thickness of 60 mm. On the
199 upper face the cap has a deeper cross groove which collect the liquid passing
200 through the porous stone which is inserted at the top of the bottom cap.
201 This connection between the sample and the external part of the cell allow
202 the possibility of drainage of water or measurement of pore pressure. For this

203 research, the hole used for this purpose has been sealed to avoid the drainage
204 of the foam along the tubes. In the upper part a similar plate is closing
205 the sample, and also in this case there is a hole for the drainage. This hole
206 has been left open both for creating the depression at the beginning which
207 allows to close the triaxial cell, and moreover to measure the pore pressure
208 generated by the conditioned mass strained in the cell.

209 This bottom cap element is fixed to a base plate made of stainless steel,
210 with a diameter of 530 mm and 60 mm thick. This element has been de-
211 signed in order to allow the passage of the drainage system, which is mostly
212 composed of the line coming from the bottom cap and from the top cap,
213 both connected through flexible pipes, from inside the pressure cell to the
214 exterior; guarantee the sealing on the contact of the cell with the base itself,
215 through a o-ring which is inserted in a groove; rigidly fasten the 4 steel bars
216 (number 2 in Figure 2). The 4 stainless steel bars (diameter 45 mm) are 1025
217 mm high and they are equipped with o-rings in the upper part in order to
218 guarantee the sealing in the top plate (number 1 in Figure 2) .

219 In the upper part of the cell, a similar cap (same size than the one on
220 the bottom) which is rigidly linked to the ram is placed in contact with the
221 sample. As already stated the drainage circuit in this case has been kept
222 in operation. Last important element of the top part is the top plate which
223 has the same thickness of the bottom one but a smaller diameter (489 mm)
224 needed to allocate the pressure cell. Also in this case the design has been
225 done to rigidly fasten the 4 steel bars and the loading ram with a pressurized
226 airtight seal and to allow the passage, also in this case with a pressurized
227 airtight seal, of the connecting cables for the transducers and the load cell

228 from inside the pressure cell and the data acquisition device.

229 The cylindrical pressure cell, as the fluid used for pressurizing the sample
230 is compressed air, is made of steel 1091 mm high, inner diameter of 491 mm
231 and thickness of 16 mm. The bottom and top extremities are thicker to
232 guarantee the tightness with the o-rings.

233 Even though the dimension of the apparatus is much larger than a com-
234 mon triaxial cell, the accuracy of the load transmission has the same im-
235 portance, and thus also the loading ram needs a perfect alignment with the
236 sample. This is especially complex due to the actuator which is providing the
237 axial force, which is a large MTS hydraulic actuator located at the MASTR-
238 LAB laboratory of the Department of Structural, Geotechnical and Building
239 Engineering of Politecnico di Torino. This device, that is really precise on
240 providing even small loads, has the problem of connecting the piston to the
241 ram in order to have a perfectly axial load. To obtain this result, a swivel
242 has been connected to a rigid steel frame which is holding the actuator and
243 moreover the connection between the piston and the ram is done by using
244 a radial spherical plain bearing, which is transmitting effectively the thrust
245 axially to the ram. The ram is inserted in a guide (Figure 3) with two ball
246 bearings which guarantee the perfectly straight direction on transmitting the
247 load to the sample. Moreover, between the two bearings there is a length of
248 50 mm in which the ram is moving in a guide with a maximum tolerance on
249 the diameter of 0.2 mm, guaranteeing the minimum loss of pressure which
250 can be easily counterbalanced with the flow of air. At the top of the guide a
251 system to lock the ram has been provided.

252 The loading ram, where is also located the loading cell, has a variable

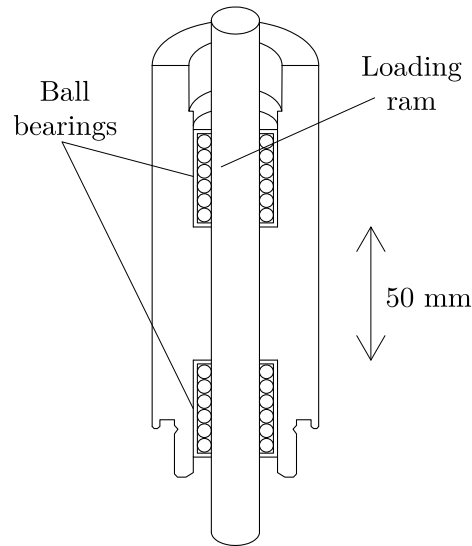

Figure 3: Guide of the loading ram.

253 length depending on the test needed (compression or extension). The max-
 254 imum stroke of the loading ram is around 150 mm, larger than the 20% of
 255 the sample height, so more than the recommended deformation needed for
 256 the triaxial test.

257 With such dimensions, the estimated volume of the sample is around 42
 258 dm^3 , much larger than a slump cone (its internal volume is around 5.5 dm^3).
 259 In this way it is possible to verify the state of the conditioned soil after the
 260 testing through a slump test, which has been always performed on the soil
 261 at the top and and the bottom of the conditioned sample.

262 3.2. Concerns about the tests

263 The study of conditioned soils through undrained triaxial tests brought
 264 to a series of considerations about the applicability of methods which are
 265 mostly used in geotechnical engineering to materials which are not typical of

266 this discipline. From the past studies of conditioned soils it is known that
267 this material cannot really be considered neither a granular material nor a
268 fluid (Vinai et al., 2007; Budach and Thewes, 2015; Mori et al., 2017). The
269 aim of this study is thus to estimate the total shear strength of the soil before
270 and after the conditioning process with similar procedure, in order to obtain
271 parameters which are directly comparable.

272 Nevertheless it is important to be careful when performing a standard
273 geotechnical test on a conditioned soil, and especially it is necessary to con-
274 sider two fundamental aspects:

- 275 1. the test procedure, the positioning of the sample and the drainage
276 condition could modify the intrinsic nature of the conditioned material.
277 This aspect is particularly evident with the loss of liquid while carrying
278 out a standard direct shear test (Martinelli et al., 2017), which resulted
279 in a reduction of content and dimension of the bubbles, and thus a
280 modification of the conditioning parameters;
- 281 2. the constitutive laws which usually are applied on evaluating the re-
282 sults of a triaxial test have been obtained under particular hypothesis,
283 with assumptions regarding the variation of volume or compressibility
284 of the different phases. These issues might not be applicable for the
285 conditioned soil, thus it is crucial to verify for each equation which one
286 can be eventually used.

287 During the testing campaign, started by using a compression loading
288 stress path, which is regularly used in geotechnical engineering tests, the tests
289 on the dry material brought satisfactory results. On the contrary, the use
290 of this type of stress path on conditioned material did not allow to perform

291 satisfactorily the test. This is mostly due to the fact that after the mold
292 is placed to confine mechanically the sample, in order to remove the mold
293 itself from the cell it is necessary to apply a negative pressure through the
294 drainage pipe (usually 20–30 kPa are enough): for the dry sample (Figure 4)
295 the process works smoothly, as the sample has no liquid; for the conditioned
296 material it did not work due to the presence of liquid under the form of
297 bubbles, which just partially saturated the sample with a relevant part of air
298 trapped between the grains of soil. In this case the grains are not directly in
299 contact, so when a depression is applied through the drainage pipe, the air
300 trapped between the grains starts to flow outside the sample, bringing the
301 foam with it and changing the volume and the state of the sample.

302 This problem brought to a necessary adjustment of the test procedure
303 for conditioned material: in this case the most suitable method is the use of
304 extension unloading stress path. This allows to skip the depression stage, as
305 the mold can be left in place because the sample is reducing its width during
306 the test and the top cap is moving upwards.

307 The two test configurations have different molds: the one for the com-
308 pression loading tests is made of two half pipe thick steel elements, linked
309 each other with bolts; the one for extension unloading tests is a polyvinyl
310 chloride pipe which is less stiff. This mold is rigidly linked at the base with
311 a lashing strap which also dovetails the membrane with the bottom cap.

312 The triaxial cell has been also used for a non-conventional test, taking
313 advantage of the equipment features: this test is performed by locking the
314 loading ram in a rigid position (no axial displacement, $\delta_a = 0$) and increasing
315 in steps the radial pressure. This type of test would allow to study the



Figure 4: Dry sand sample with the external depression applied

316 behaviour of the conditioned material at different pressures, especially it is
317 important to verify the difference between the applied confinement radial
318 pressure σ_r and the pressure induced by the fluids trapped in the soil in the
319 sample (pore pressure p_p), which is present when the material is still fluid
320 with the grain separated (the air is still able to deform).

321 *3.3. Testing procedure*

322 The main use of the apparatus in its original configuration is the testing
323 of granular soils with compressive stress paths, carried out under control of
324 load or deformation, both drained or undrained.

325 The testing procedure has been proposed both for the dry and the condi-
326 tioned material, but after the first test in the conditioned soil the procedure
327 has been changed, as the compression loading stress path was not possible
328 due to the difficulties on creating the necessary void needed for removing the
329 mold. For this reason the conditioned material has been tested by using an
330 extension unloading stress path, which would not require the removing of the
331 mold, as the sample is reducing its width during the test.

332 The tests performed during this research have been of three types, de-
333 pending on the material and the needs:

- 334 1. compression loading test (axial pressure σ_a and axial displacement δ_a
335 increasing, radial pressure σ_r constant);
- 336 2. extension unloading test (axial pressure σ_a and axial displacement δ_a
337 decreasing, radial pressure σ_r constant);
- 338 3. lateral confinement increase test (axial displacement $\delta_a = 0$, radial
339 pressure σ_r increasing in steps);

340 In this research the modified triaxial test consists mainly on these oper-
341 ations:

- 342 1. *preparation of the sample.* The material is placed inside the rubber
343 membrane which is rigidly linked to the mold. The dry material is
344 inserted in layer, and as it is a non-cohesive dry material, it has been

345 placed in its natural state, without pressing it. Also in the conditioned
346 material case, the material appears so fluid that it flows almost like
347 water in the mold. The most critical part for the conditioned soil
348 testing is the time, as the foam is naturally degrading in the time. The
349 test was attempted to be carried out within 60–90 minutes, in any case
350 this parameter has been always registered.

351 It is also well known that the behaviour of the conditioned soil is not
352 only related to the foam half-life time (up to 20–30 minutes with high
353 concentrations of surfactants), but especially by the life of the bubbles
354 in the soil itself, that normally is much larger. This is even more
355 evident while confining the samples in a closed tank and mixing it
356 before the insertion in the mold. This aspect has been investigated
357 while preparing the optimal conditioning of the two soils and it will be
358 discussed in Section 4.1 (Figure 7).

359 The phases of preparation depend on the material to be studied and
360 the testing type. The common operations are as follows:

- 361 (a) the bottom cap is cleaned and its lateral surface is covered with a
362 layer of silicone greased;
- 363 (b) the porous stone and the filter paper are placed over the bottom
364 cap;
- 365 (c) the rubber membrane is inserted in the bottom cap, in contact
366 with the grease;
- 367 (d) the mold is placed on the bottom cap and the membrane is turned
368 over it in the upper part;
- 369 (e) the membrane is filled with the material to be tested. The dry
370 material is inserted in layer, and as it is a non-cohesive dry mate-

371 rial, it was placed in its natural state, without pressing it. Also in
372 the conditioned material case, the material appears so fluid that
373 it flows almost like the water in the mold;

374 (f) once the material fills the membrane and the mold for the nec-
375 essary height (600 mm), the material is levelled off in order to
376 obtain a perfectly straight and uniform surface. Over this surface
377 a filter paper is placed in contact with the porous stone which is
378 embedded in the top cap;

379 (g) connection of the membrane with the top cap, greased in the same
380 way of the bottom cap, and application of o-rings to fasten the
381 membrane over the cap;

382 2. *assembly of the apparatus.* This phase regards all those operations
383 concerning the assembling of all the mechanical components, the dis-
384 position and connection of all the sensors and to the configuration of
385 the system actuator;

386 3. *consolidation.* This phase allows to apply any initial stress condition
387 to the sample, in this research the initial condition applied to the sam-
388 ple has been always isotropic, in order to reproduce as much as it is
389 possible the hydrostatic conditions. This phase is usually performed,
390 as in this research, load controlled. It represents the first actual part of
391 testing of the sample and it is performed by removing the depression
392 and applying the radial pressure (compression loading tests) or just by
393 applying the radial pressure (extension unloading tests). The most im-
394 portant issue regarding this phase is the perfect combination between
395 radial pressure applied by the compressed air, which is flowing into

396 the cylindrical pressure cell, and the the axial load applied with the
397 loading ram: these values in fact must be kept equal in order to fulfill
398 the initial isotropic condition of the sample. Once the desired confine-
399 ment pressure is reached and the axial load is balanced to obtain the
400 isotropic condition, this state is usually kept for several minutes be-
401 cause, especially in clays, viscous deformation can occurs; nevertheless
402 in the case of conditioned material the presence of bubbles which are
403 naturally degrading this operation should be neglected in order to keep
404 the material as much as possible in the initial state.

405 4. *test execution.* The actuator is moving the loading ram in order to
406 apply the load. This phase is usually performed, as in this research,
407 deformation controlled. The test is ending at the limit stroke of the
408 piston, usually after reaching the peak strength and during the post-
409 peak phase.

410 4. Testing campaign carried out

411 4.1. Soils tested

412 The apparatus has been used for testing two natural soils: Soil A and Soil
413 B (Figure 5), characterized by grain size distributions as in Figure 6. These
414 two soils represent possible lithologies to be encountered during an EPB
415 excavation, and they fit the range of optimal application for this technology
416 (Budach and Thewes, 2015).

417 As a preliminary stage of this research, the optimal soil conditioning
418 through slump testing for the two materials has been assessed. The results
419 are summarized in Figure 7 and Table 1.

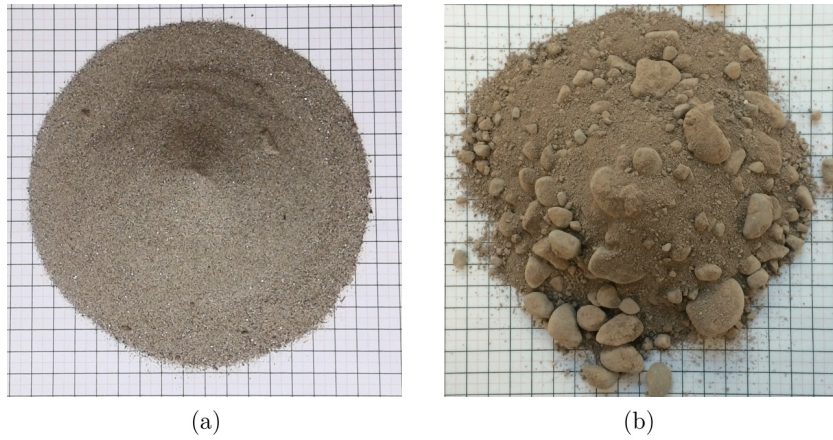

Figure 5: Photos of Soil A (a) and Soil B (b). The reference square size is 1 cm x 1 cm.

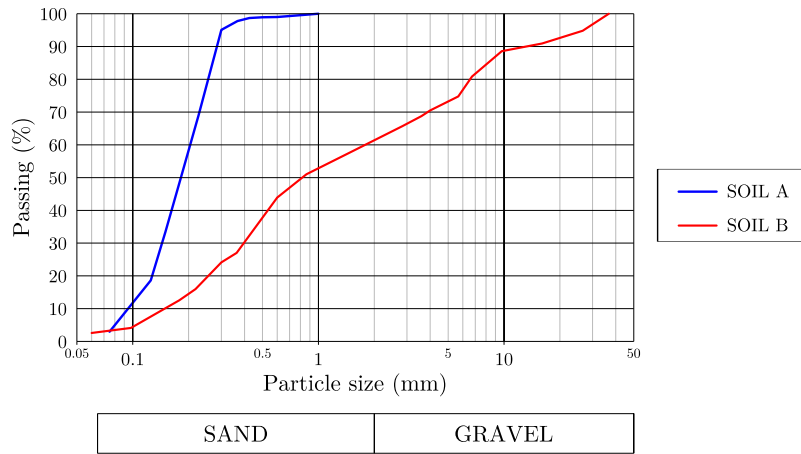

Figure 6: Grain size distributions of the two soils used for this research

Table 1: Optimal conditioning parameters for the soils studied

Parameter	Soil A	Soil B
Natural water content (in weight), w_{nat} (%)	0	0
Final water content (in weight), w_{fin} (%)	20	10
Surfactant concentration in the liquid generator, c (%)	2	2
Half-life time of the foam, t_{50} (s)	770	710
Foam Expansion Ratio, FER (-)	15	12
Foam Injection Ratio, FIR (%)	80	50
Slump (cm)	20	18

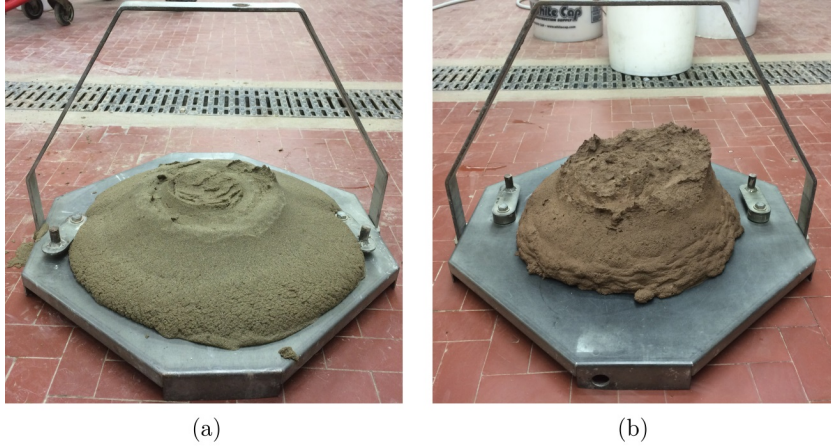

Figure 7: Photos of optimal slump for Soil A (a) and Soil B (b).

420 The preparation of the conditioned soil samples has been always carried
421 out by using a well established procedure consisting in (Peila et al., 2009;
422 Martinelli et al., 2018):

- 423 • preparation of the natural sample to be tested (for filling the triaxial
424 cell around 45–50 kg);
- 425 • mixing of the sample with the water to be added to reach the final
426 water content w_{fin} ;
- 427 • generation of the required amount of foam according to a specific FER
428 and FIR ;
- 429 • mixing of the soil and the foam at room pressure in a standard concrete
430 mixer (time around 3-5 min at 25 rpm);
- 431 • insertion of the conditioned sample into the testing mold of the triaxial
432 apparatus.

433 The foam generator used is produced by Spoilmaster Ltd (UK). The sys-
434 tem allows the control of the flow of water and the air flow rate, as well as the
435 control of the dosage of the foaming agent. Once the operating parameters
436 are set, except modest fluctuations, the foam with the FIR defined a priori
437 can be produced. However, before the execution of each test, a verification
438 of the FER is performed by weighing a pre-determined volume of foam.

439 4.2. Testing campaign

440 The first campaign of tests has been carried out on Soil A, by using the
441 compression loading stress path. The natural dry soil did not present any

442 particular problem during the testing, while when testing the conditioned
443 samples it was not possible to apply the depression, as stated in Section 3.2.
444 For this reason the testing method has been changed by using a different
445 stress path, that is the extension unloading. In this way the problem of
446 applying effectively the depression can be overtaken.

447 The campaign carried out on Sand B has been performed just by using
448 the extension unloading stress path. First of all the dry samples have been
449 studied, in order to get the shear strength which was not possible to assess
450 with the shear test. Then a campaign of tests has been carried out on the
451 conditioned samples.

452 Both the dry and conditioned samples have been directly inserted into
453 the mold thanks to the absence of cohesion for the first and excellent fluidity
454 for the second. Every 20 cm the layer of material has been regularized up to
455 the top and the final stratum is well-groomed with an aluminium bar.

456 The use of two stress paths on the testing, brought of course to two
457 different failure of the samples, by compression or by extension. A picture of
458 the broken samples in the two cases is presented in Figure 8. The measured
459 parameters, needed for this research, are the vertical load, the confinement
460 pressure and the displacement of the piston.

461 **5. Results**

462 *5.1. Soil A*

463 The campaign on this soil has been carried out first using compression
464 loading configuration by using 3 different confinement pressures of 150 kPa,
465 200 kPa and 300 kPa. Nevertheless, considering the aspects already described

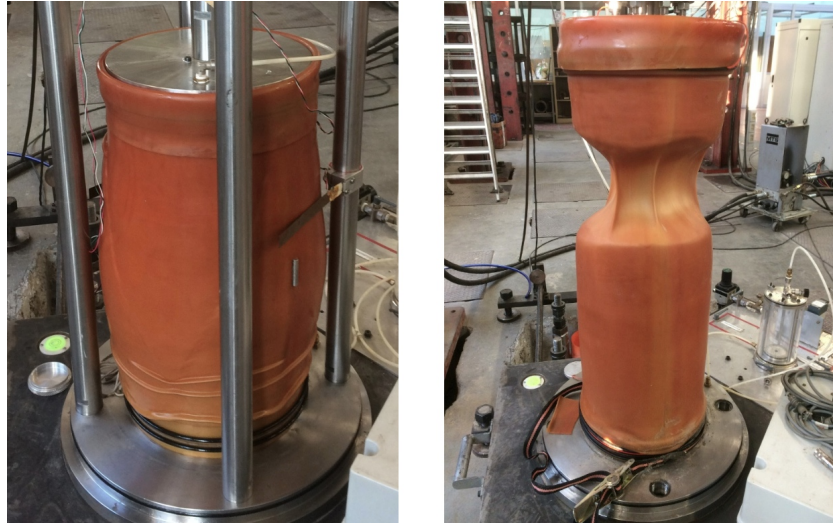

Figure 8: Samples after the failure at the end of a compression loading (left) and extension unloading (right) tests.

466 in 3.2, when testing the conditioned soil with the compression loading test,
467 the depression was not guaranteed and the tests have been carried out by
468 using extension unloading configuration. In order to better compare the
469 results, also on dry Soil A a campaign of extension unloading triaxial tests
470 have been performed using the same confinement pressures.

471 The results of the campaign obtained from the 6 tests are summarized
472 in the plot in Figure 9. With this values, it is possible to obtain the Mohr-
473 Coulomb failure envelope through the Mohr's circle in Figure 10.

474 Regarding the conditioned samples, the campaign has been carried out
475 by using 4 different confinement pressures σ_r equal to 100 kPa, 250 kPa, 325
476 kPa and 400 kPa. The choice of using an additional test compared to the
477 usual procedure is due to the results given from the test with $\sigma_r = 100$ kPa
478 which returned a unusual graph. This might be explained by the fact that

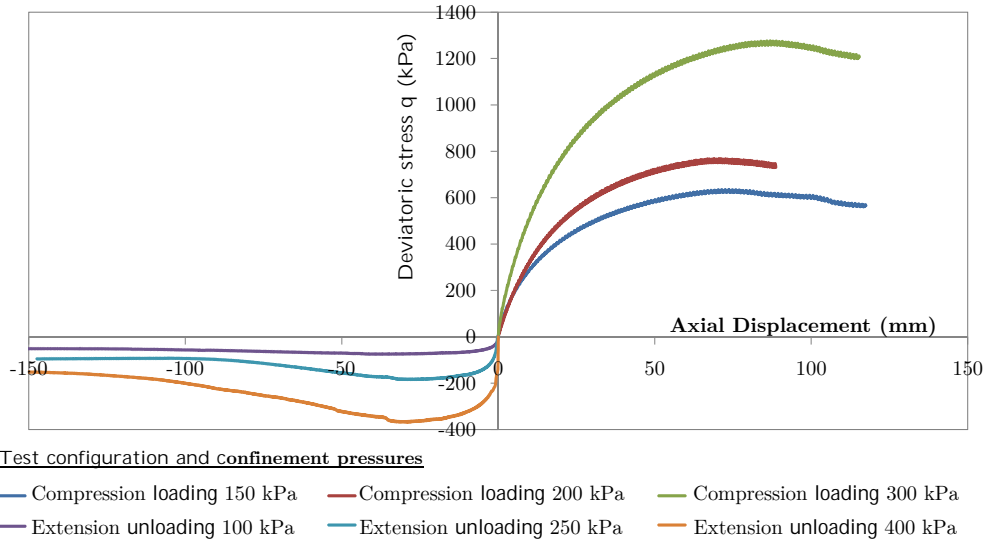

Figure 9: Outcome of the triaxial campaign on dry Soil A.

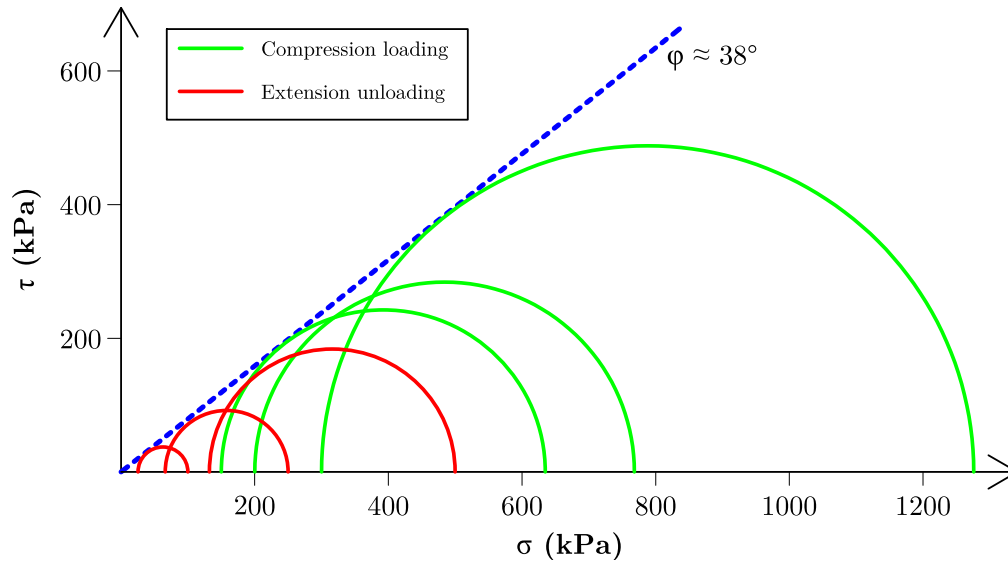

Figure 10: Failure envelope and Mohr's circles from the triaxial tests performed on the dry Soil A.

479 the material is acting completely as a fluid at this confinement, and does
 480 not reach a pressure able to compress the bubbles enough to guarantee the
 481 contact between the grains. In this state, at this pressure, the material can
 482 transmit effectively the pressure in a EPB shield excavating chamber. The
 483 results of the triaxial testing on conditioned Soil A are plotted in Figure 11.

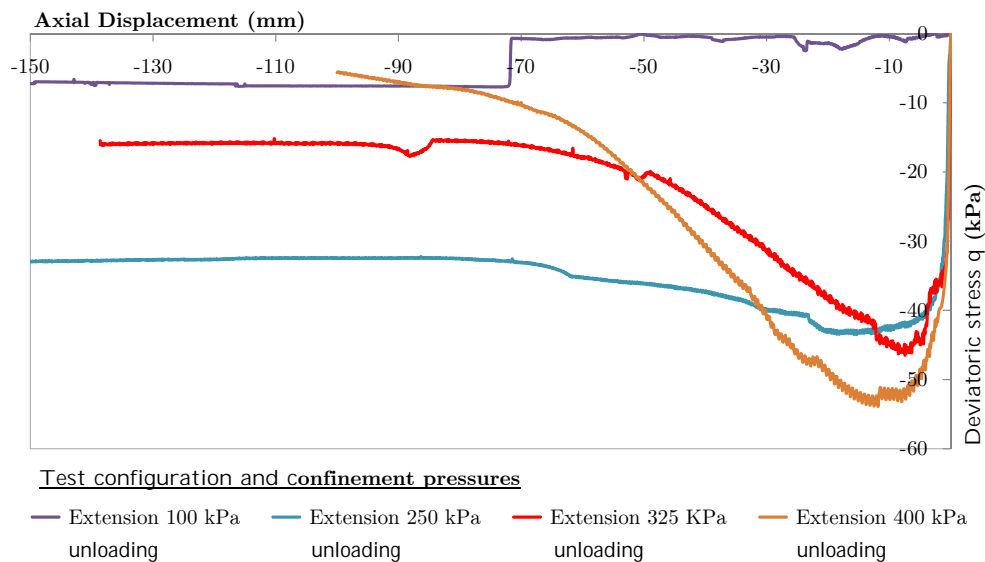

Figure 11: Outcome of the triaxial campaign on conditioned Soil A.

484 Another test performed on the conditioned sand, carried out in order to
 485 assess the behaviour of the mass during the application of the pressure in the
 486 cell, is the lateral confinement increase test. The maximum reached pressure
 487 has been set to 500 kPa. The test has been performed in steps of 50 kPa after
 488 the first pressure set to 150 kPa and each step has been kept some minutes
 489 (around 5-6 minutes) to stabilize the pressures. The outcome of this test is
 490 shown in Figure 12: while the radial confinement pressure σ_r is increasing,
 491 there is a direct and equal response of the pore pressure p_p up to 10–120 kPa,

492 and then this response is stabilizing the p_p which remains almost constant
 493 while the σ_r reaches 500 kPa.

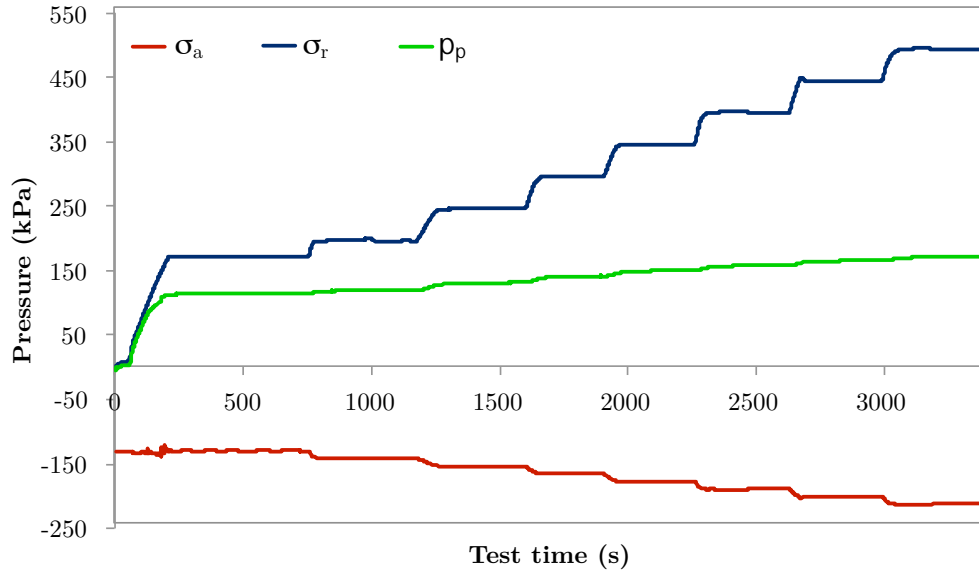

Figure 12: Triaxial lateral confinement increase test of conditioned Soil A up to $\sigma_r = 500$ kPa. σ_a is the registered induced axial pressure, σ_r is the applied radial confinement pressure and p_p is the registered pore pressure in the sample.

494 For better understanding the mechanical behaviour of the conditioned
 495 mass under different pressure conditions and the response of the p_p with
 496 different values of σ_r , the results obtained from the test campaign on con-
 497 ditioned Soil A have been plotted together in Figure 13. In this graph the
 498 outcomes of the 5 tests are represented in Y-axis with the Δ pressure, which
 499 is representing difference between the pressure applied in the cell σ_r and the
 500 pore pressure p_p , and in X-axis the σ_r itself. This graph is interesting to
 501 understand the moment in which the material is starting to become more
 502 rigid due to the contact between the grains as shown in Figure 1. The graph

503 shows that for confinement pressures σ_r lower than 150 kPa the Δ pressure
 504 is small, confirming the fact that at 100 kPa of confinement the material is
 505 still behaving as a fluid.

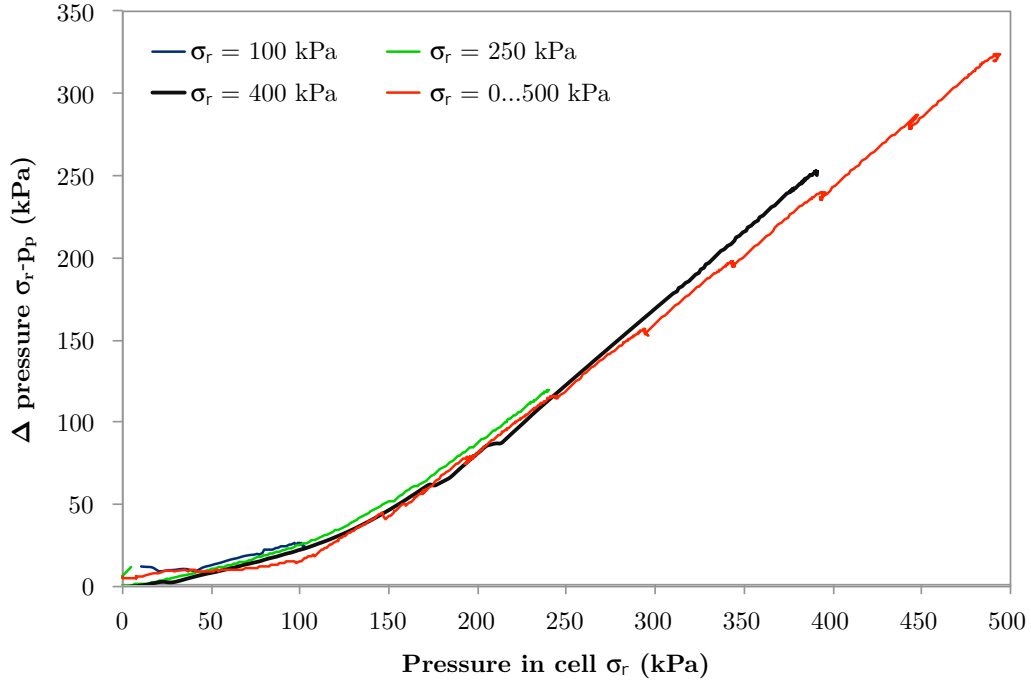

Figure 13: Δ pressure vs. pressure in the cell (σ_r) for the conditioned Soil A.

506 Another important result is given by an unexpected failure of the mem-
 507 brane which occurred during the test with $\sigma_r = 400$ kPa much after the peak.
 508 In Figure 14 this event is showed through a pressure vs. time graph which
 509 shows the axial pressure peak at around 500 s from the test starting and the
 510 failure of the membrane, indicated by the sudden rise of the pore pressure
 511 to the cell pressure. After the removal of the cell the failure was visible from
 512 the membrane, with the foam flowing out from the sample. This failure has
 513 proved to be positive, as in this way it was possible to check the behaviour

514 of the material in drained conditions.

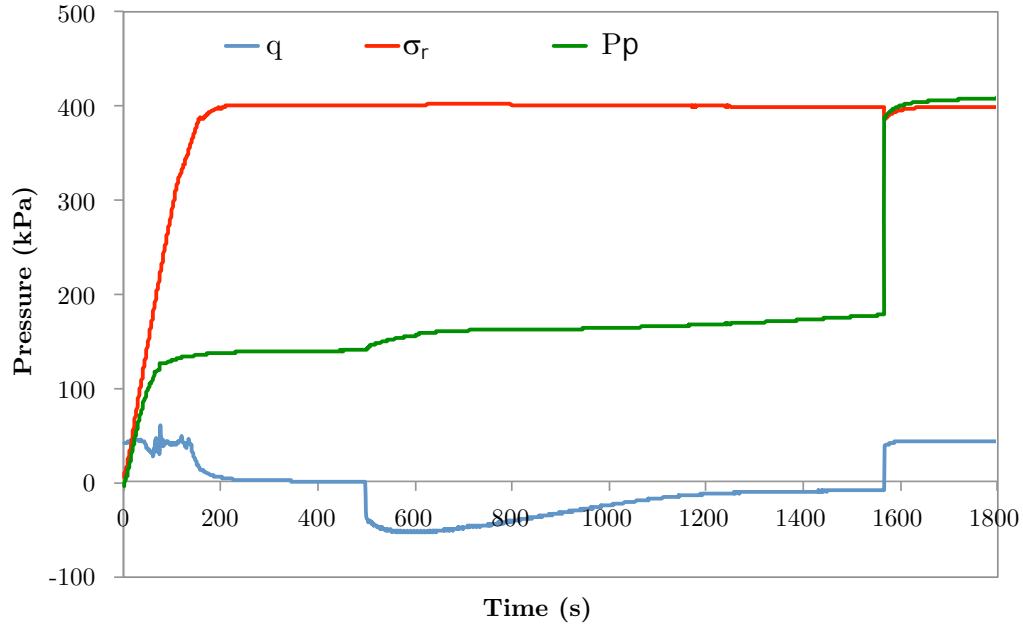

Figure 14: Graph pressure vs. time of the triaxial test on conditioned Soil A with $\sigma_r = 400$ kPa with the evidence of the membrane failure (the pore pressure p_p reaches the same value of the applied confinement pressure σ_r).

515 After each test on conditioned Soil A, slump test has been carried out
516 to verify the quality of the mass after the triaxial test. Table 2 shows the
517 results of all the tests carried out on the material at room pressure which was
518 stored in a sealed tank during the triaxial test and on the material inside the
519 membrane in the top and bottom part. In this way also the stability of the
520 mass can be assessed: if the top and bottom samples are similar, it means
521 that the foam is not flowing down because of the gravity. Also from this
522 test it has been possible to notice the difference of behaviour of the material
523 in drained and undrained conditions: at the row corresponding to $\sigma_r = 400$

524 kPa, the top slump shows a dry material due to the failure of the membrane,
525 on the contrary the bottom slump shows that the material kept its properties
526 due to the good stability of the conditioned mass which prevented too big loss
527 of foam through the breach on the membrane: in this test the conditioned
528 soil collected from the top, the part where the failure happened, appears to
529 be much stiffer loosing completely its workability although still wet. This is
530 caused by the loss of the foam which was able to flow through the membrane
531 due to the applied pressure. The slump for this sample has returned a value
532 equal to just 3 cm (result highlighted in red in Table 2).

533 This represents an important result, as it is clear that in most of the cases
534 the bubbles which where strained by the increase of the lateral pressure were
535 still visible from the material collected from the triaxial apparatus after the
536 test and from the slump test itself, meaning that they were not broken after
537 the triaxial loading, but just deformed (Figure 15).

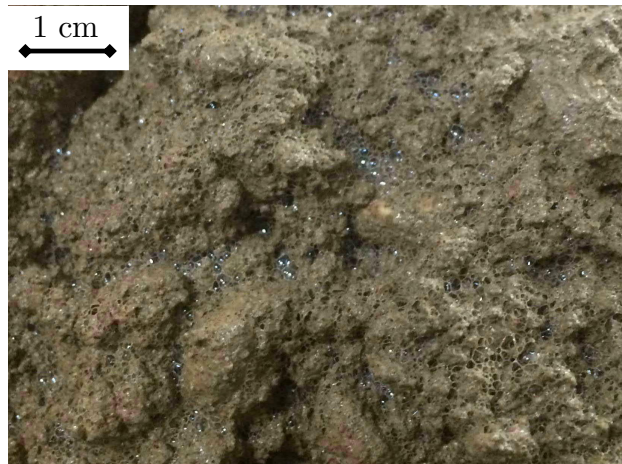

Figure 15: Conditioned sample of Soil A collected just after the triaxial testing. The material has still a good workability and foam bubbles are clearly visible.

Table 2: Slump values and pictures from the samples taken after each triaxial test. For each pressure there is a slump of the sample at room pressure (P_0), from the top and from the bottom of the cell. The colours identify a suitable (green), borderline (yellow) or unsuitable (red) slump.

σ_r (kPa)	Time (min)	Slump (cm)		
		P_0	Top	Bottom
100	160	22	19	17
250	135	22	18	18
325	135	21	17	19
400	150	22	3	14
0...500	180	23	19	16

538 5.2. Soil B

539 The campaign on this soil has been carried out just using extension un-
540 loading configuration by using 3 different confinement pressures of 100 kPa,
541 250 kPa and 400 kPa.

542 The results of the campaign obtained from the 3 tests are summarized in
543 the plot in Figure 16. With this values, it is possible to obtain the Mohr-
544 Coulomb failure envelope through the Mohr's circle in Figure 17.

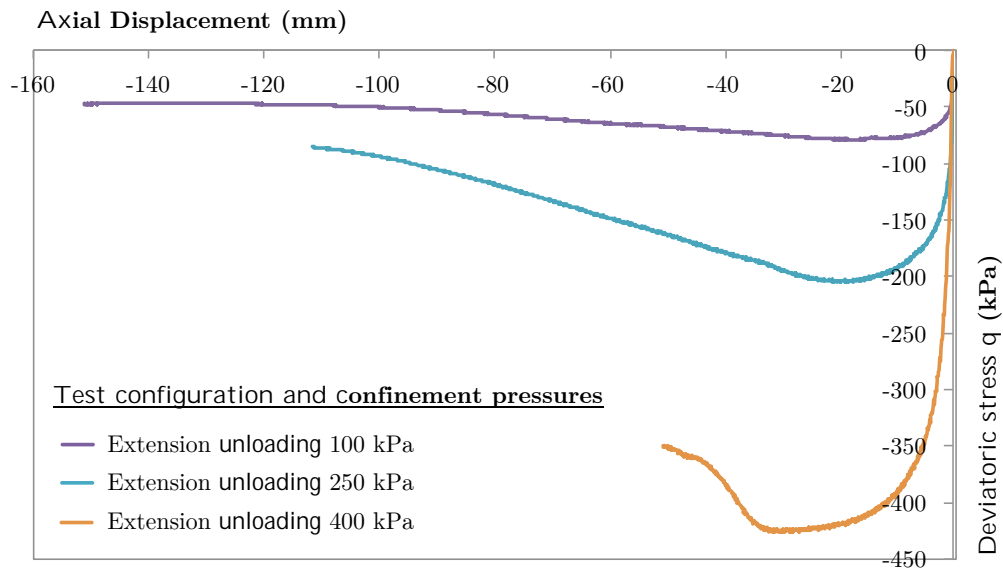

Figure 16: Outcome of the triaxial campaign on dry Soil B.

545 Regarding the conditioned samples, the testing has been more difficult
546 compared to the previous material. Two tests have been performed with
547 confinement pressures equal to 150 and 250 kPa; the test with this last σ_r
548 has been repeated twice because the first test did not return valid results.
549 Although the testing campaign did not return the expected results, anyhow

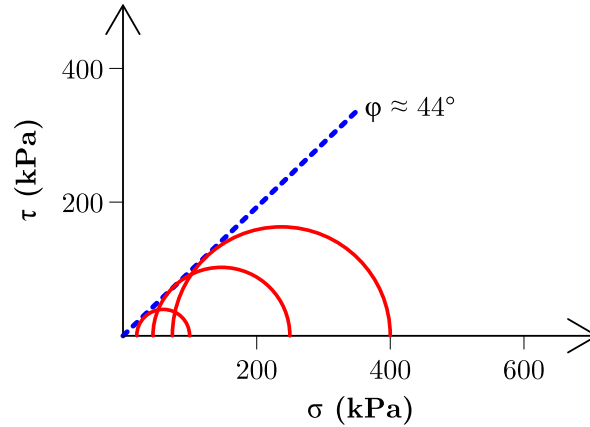

Figure 17: Failure envelope and Mohr's circles from the triaxial tests performed on the dry Soil B.

550 the overall behaviour of the material during the testing phases was sufficient
 551 to give useful indications. The results of these tests are shown in Figure 18.

552 Also for this soil the lateral confinement increase test has been carried
 553 out by increasing the cell pressure σ_r up to 500 kPa. In this case the test
 554 has been performed just after the two tests recorded in Figure 18, in order
 555 to check the behaviour of the conditioned mass through the measured pore
 556 pressure response (Figure 19).

557 The outcome of these two variants of the test are showing a slight differ-
 558 ent behaviour of the conditioned mass: as a matter of fact the samples are
 559 behaving effectively when the pressure is increased, probably due to the fluid
 560 behaviour of the fine part of the soil (clay and silt). In fact the clayey condi-
 561 tioned soils are usually transmitting the pressure much more effectively, thus

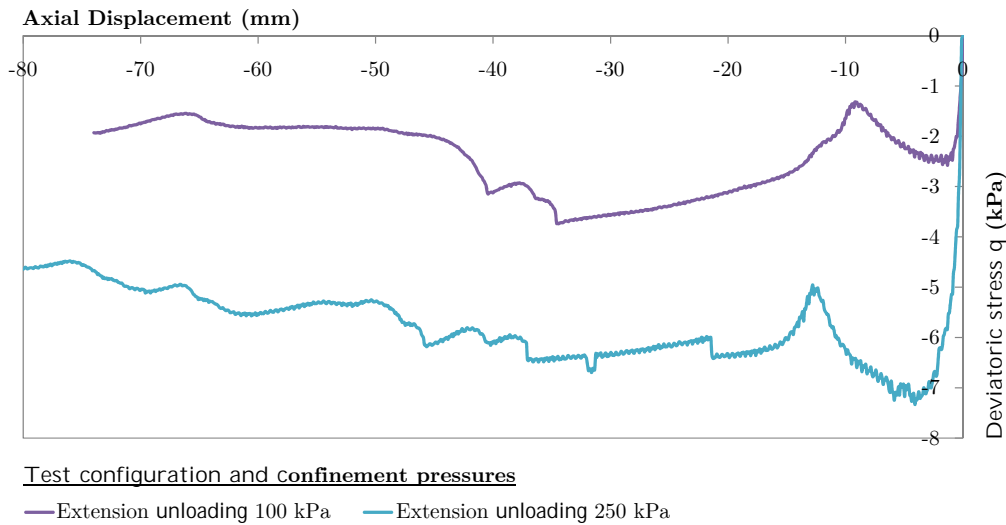

Figure 18: Outcome of the triaxial campaign on conditioned Soil B.

562 also in this case the finer part is helping the increase of the pore pressure.

563 5.3. Analysis of the results

564 The campaign carried out on Soil A returned interesting results regarding
 565 the comprehension of the mechanical behaviour of the conditioned masses.
 566 The method allows to easily compare the behaviour of the material in differ-
 567 ent states, by studying similar parameters proper to geotechnical engineering
 568 and especially by assessing parameters useful to mechanized tunnelling en-
 569 gineering. These lasts include the verification of the attitude of the material
 570 of transmitting effectively pressure during the stress increase phase and the
 571 verification after the test of the condition of the mass through for example
 572 slump testing.

573 The testing carried out on Soil B underlined, especially through the in-
 574 creasing confinement tests shown in Figure 18, the good attitude of the ma-

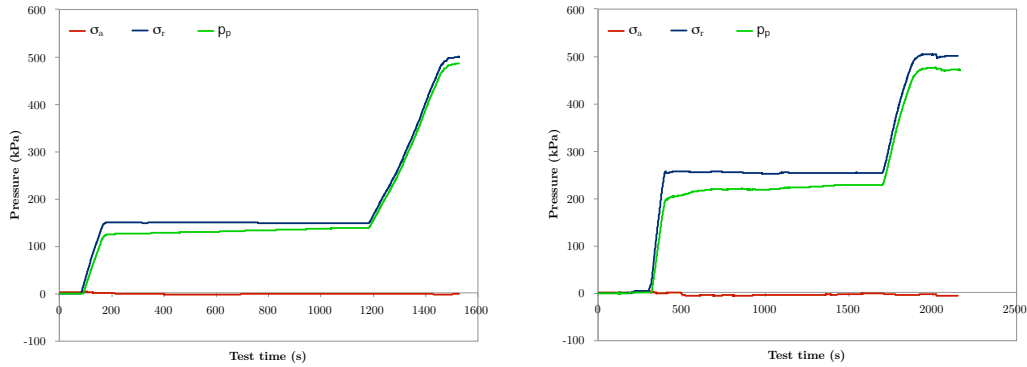

Figure 19: Plots of the radial pressure increase in the triaxial tests with initial confinement $\sigma_r = 100$ kPa (left) and $\sigma_r = 250$ kPa (right). σ_a is the registered induced axial pressure, σ_r is the applied radial confinement pressure and p_p is the registered pore pressure in the sample.

575 terial on behaving more like a fluid at higher pressures as well, as in this case
 576 it is not noticeable a true contact between grains as in Soil A. In fact the
 577 conditioned Soil B sample has a behaviour similar to the toothpaste, as the
 578 fine part is creating a slurry made of clay/silt, water and surfactant.

579 The use of extension unloading stress path allows to avoid to apply the
 580 negative pressure to a sample which is not saturated and needs to keep the
 581 air trapped inside the conditioned mass in form of foam bubbles.

582 6. Conclusions

583 The increasing number of EPB tunneling applications with high pressure
 584 in the chamber has pushed the researchers to concentrate the researches in
 585 this field to better understand the influence of this parameter in the con-
 586 ditioned soil behaviour. In this field remarkable laboratory researches have
 587 been carried out by Psomas (2001) and Mori et al. (2018) who using a con-

588 fined compression device have demonstrated the influence of the pressure on
589 the void index of the conditioned mass. The present research has the goal to
590 provide further information of the behaviour of conditioned rock mass under
591 pressure using a large size triaxial test device. The obtained results cannot
592 be applied directly to the design of conditioning but they form one side con-
593 firm the behaviour observed by Psomas (2001) and Mori et al. (2018) and
594 give further information on the important influence of pressure on the soil
595 behaviour.

596 A campaign of large diameter triaxial tests has been conducted on two
597 different conditioned soils, in order to study their behaviour in triaxial stress
598 conditions. The obtained results show a clear trend of the conditioned ma-
599 terial of behaving as a fluid a low confinement pressure, where the grains
600 are not in contact each others and the foam is creating a floating barrier
601 between them and reducing the shear strength; on the contrary at higher
602 pressures the materials are becoming stiffer and the shear strength increases.
603 The campaign underlined also the main difference between a typical granular
604 material as Soil A and a more heterogeneous material containing also clay
605 and silt as Soil B: in the first the contact between the grains is more evident,
606 as by increasing the confinement pressure over 150 kPa the measured fluid
607 pressure remains constant; in the second case the fluid pressure is increasing
608 while increasing the confinement pressure due to the fine part that is acting
609 like a slurry strained by the radial pressure.

610 Another important result has been obtained by the slump campaign on
611 the material tested in the triaxial cell, in most of the cases the bubbles which
612 where strained by the increase of the lateral pressure were still visible from

613 the slump test itself, meaning that they were not broken after the triaxial
614 testing, but just deformed and reduced in volume. The failure on one triaxial
615 test allowed moreover to verify the state of the conditioned material after
616 braking the membrane, reaching a drained condition: in this case the loss of
617 foam returned the material stiffer.

618 The use of this cell for assessing the behaviour of the conditioned material
619 in triaxial stress conditioned allowed to better understand the response of this
620 material in a possible EPB application and potentially helps the suitability
621 of the conditioning for applying an effective counterpressure to the front of
622 a tunnel. A direct assess of the situation in the work chamber must be
623 investigated in the future, by correlating the parameters obtained by this
624 test with real data.

625 **7. Author contributions and acknowledgements**

626 The work has been carried out by Dr. Daniele Martinelli during his PhD
627 thesis preparation; Mr. Carmine Todaro and Dr. Andrea Luciani contributed
628 on the preparation and the revision of the work and Prof. Daniele Peila
629 supervised and revised the work. Authors would like to acknowledge staff of
630 the DISEG laboratory, in particular Dr. Oronzo Vito Pallara for helping on
631 preparing the apparatus and the acquisition. Part of this work was part as
632 well of the Master's Thesis of Maura Pirone, who is also acknowledged.

- 633 Anagnostou, G., Kovári, K., 1996. Face stability in slurry and EPB shield
634 tunnelling. In: Mair, R., Taylor, D. W. (Eds.), Geotechnical Aspects of
635 Underground Construction in Soft Ground. Vol. 3. pp. 453–458.
- 636 Bezuijen, A., Joustra, J., Talmon, A., Grote, B., 2005. Pressure gradients at
637 the tunnel face of an earth pressure balance shield. Proc. ITA.
- 638 Budach, C., Thewes, M., 2010. Soil conditioning with foam during epb tun-
639 nelling. Geomechanics and Tunnelling 3, 256–267.
- 640 Budach, C., Thewes, M., 2015. Application ranges of epb shields in coarse
641 ground based on laboratory research. Tunnelling and Underground Space
642 Technology 50, 296–304, cited By :17.
643 URL www.scopus.com
- 644 Fiorio, S., 2003. Una cella triassiale per prove sforzi – deformazioni - re-
645 sistenza su terreni a grana grossa : metodologie sperimentali. Master’s
646 thesis, Politecnico di Torino.
- 647 Galli, M., Thewes, M., 2016. Rheology of Foam-Conditioned Sands in EPB
648 Tunneling. In: World Tunnel Congress 2016. San Francisco, USA, 25–27
649 April 2016.
- 650 Herrenknecht, M., 1994. EPB or slurry machine: the choice. Tunnels and
651 Tunnelling 26 (6), 35–6.
- 652 Jaky, J., 1948. Pressure in silos. In: 2nd ICSMFE, Rotterdam. Vol. 1. pp.
653 103–107.

- 654 Lancellotta, R., 2009. Geotechnical Engineering, 2nd Edition. Tay-
655 lor&Francis, London.
- 656 Lovat, P. R., 2006. TBM Design Considerations: Selection of Earth Pressure
657 Balance or Slurry Pressure Balance Tunnel Boring Machines. In: Interna-
658 tional Symposium on Utilization of Underground Space in Urban Areas.
659 Sharm El-Sheikh, Egypt, 6–7 November 2006.
- 660 Maidl, U., Hintz, S., 2003. Comparative analysis between the support of the
661 tunnel face with foam (EPB) or bentonite (slurry shield) in dutch soft
662 ground. In: World Tunnel Congress 2003. Amsterdam NL. pp. 773–778.
- 663 Mair, R., Merritt, A., Borghi, X., Yamazaki, H., Minami, T., 2003. Soil
664 conditioning for clay soils. T & T international 35 (4), 29–33.
- 665 Martinelli, D., 2016. Mechanical behaviour of conditioned material for EPBS
666 tunnelling. Ph.D. thesis, Politecnico di Torino, Italy.
- 667 Martinelli, D., Chierigato, A., Onãte Salazar, C. G., Barbero, M., Peila,
668 D., 2015a. Conditioning of fractured rock masses for the excavation with
669 EPB shields. In: ISRM International Congress on Rock Mechanics 2015.
670 International Society for Rock Mechanics, Montréal, CA, 10–13 May 2015.
- 671 Martinelli, D., Peila, D., Campa, E., December 2015b. Feasibility study of
672 tar sands conditioning for earth pressure balance tunnelling. Journal of
673 Rock Mechanics and Geotechnical Engineering 7 (6), 684–690.
- 674 Martinelli, D., Todaro, C., Luciani, A., Peila, L., Carigi, A., Peila, D., 2018.
675 Moderno approccio per lo studio del condizionamento dei terreni granu-

- 676 lari non coesivi per lo scavo con macchine EPB. Gallerie e Grandi Opere
677 Sotterranee 128, 23–31.
- 678 Martinelli, D., Winderholler, R., Peila, D., 2017. Undrained behaviour of
679 granular soils conditioned for epb tunnelling a new experimental procedure
680 tunnelling. Geomechanik und Tunnelbau 10 (1), 81–89, cited By :2.
681 URL www.scopus.com
- 682 Merritt, A., Borghi, F., Mair, R., 2003. Conditioning of clay soils for earth
683 pressure balance tunnelling machines. Proceedings of Underground Con-
684 struction 2003, 455–466.
- 685 Milligan, G., 2000. State-of-the-art review: Lubrification and Soil Condition-
686 ing. Tech. rep., Geotechnical Consulting Group.
- 687 Mooney, M. A., Wu, Y., Mori, L., Bearce, R. G., 2016. Earth pressure balance
688 tbn soil conditioning: It’s about the pressure. In: World Tunnel Congress
689 2016. San Francisco, USA, 25–27 April 2016.
- 690 Mori, L., Alavi, E., Mooney, M., 2017. Apparent density evaluation methods
691 to assess the effectiveness of soil conditioning. Tunnelling and Underground
692 Space Technology 67, 175–186, cited By :1.
693 URL www.scopus.com
- 694 Mori, L., Mooney, M., Cha, M., 2018. Characterizing the influence of stress
695 on foam conditioned sand for epb tunneling. Tunnelling and Underground
696 Space Technology 71, 454–465, cited By :1.
697 URL www.scopus.com

- 698 Mori, L., Wu, Y., Cha, M., Mooney, M. A., 2015. Measuring the compress-
699 ibility and shear strength of conditioned sand under pressure. In: Johnson,
700 M. C., Oginski, S. (Eds.), Rapid Excavation and Tunneling Conference. So-
701 ciety for Mining, Metallurgy, and Exploration (SME), New Orleans, LA,
702 USA, 27–30 June 2015, pp. 1253–1260.
- 703 Peila, D., 2009. Indagini preliminari nella costruzione di gallerie: analisi della
704 letteratura tecnica. *Geoingegneria Ambientale e Mineraria* 128 (3), 23–44.
- 705 Peila, D., 2014. Soil conditioning for EPB shield tunnelling. *KSCE Journal*
706 *of Civil Engineering* 18 (3), 831–836.
- 707 Peila, D., Oggeri, C., Borio, L., 2009. Using the slump test to assess the
708 behavior of conditioned soil for EPB tunneling. *Environmental & En-
709 gineering Geoscience* 15 (3), 167–174.
- 710 Peila, D., Picchio, A., Martinelli, D., Dal Negro, E., October 2016. Labo-
711 ratory tests on soil conditioning of clayey soil. *Acta Geotechnica* 11 (5),
712 1061–1074.
- 713 Psomas, S., 2001. Properties of foam/sand mixtures for tunnelling applica-
714 tions. Master’s thesis, University of Oxford Michaelmas.
- 715 Thewes, M., 2007. TBM tunnelling challenges - redefining the state-of-the-
716 art. keynote lecture at the 2007 itaworld tunnel congress, prague. 16, 13–21.
- 717 Thewes, M., 2014. Choice of tunnelling machine (EPB vs. Slurry). In: Work-
718 shop on Ground-Related Risk in Soft Ground Shield Tunnelling, Tun-
719 nelling and Underground Construction Society (TUCSS), Singapore, 17.
720 Oct. 2014. pp. 729–735.

- 721 Thewes, M., Budach, C., Bezuijen, A., 09 2012. Foam conditioning in EPB
722 tunnelling. pp. 127–135.
- 723 Thewes, M., Budach, C., Galli, M., 2010. Laboratory tests with various con-
724 ditioned soils for tunnelling with earth pressure balance shield machines.
725 Tunnel - International Journal For Subsurface Use 1 (6), 21–30.
- 726 Vinai, R., Borio, L., Peila, D., Oggeri, C., Pelizza, S., 2008. Soil conditioning
727 for EPB Tunnelling. T & T international 12.
- 728 Vinai, R., Oggeri, C., Peila, D., 2007. Soil conditioning of sand for EPB
729 applications: A laboratory research. Tunnelling and Underground Space
730 Technology 23 (3), 308–317.
- 731 Yang, Y., Li, X., Li, X., 2018. Shear strength and compression coefficient
732 for conditioned sand subjected to earth chamber stress levels. Advances in
733 Materials Science and Engineering 2018.
734 URL www.scopus.com
- 735 Zumsteg, R., Plötze, M., Puzrin, A., 2013a. Effects of dispersing foams and
736 polymers on the mechanical behaviour of clay pastes. Géotechnique 63 (11),
737 920–933.
- 738 Zumsteg, R., Plötze, M., Puzrin, A., 2013b. Reduction of the clogging po-
739 tential of clays: new chemical applications and novel quantification ap-
740 proaches. Géotechnique 63 (4), 276–286.