

What's around the curve? A driving simulation experiment on compensatory strategies for safe driving along horizontal curves with sight limitations

Original

What's around the curve? A driving simulation experiment on compensatory strategies for safe driving along horizontal curves with sight limitations / Bassani, M., Hazoor, A., Catani, L.. - In: TRANSPORTATION RESEARCH PART F: TRAFFIC PSYCHOLOGY AND BEHAVIOUR. - ISSN 1369-8478. - ELETTRONICO. - 66:(2019), pp. 273-291. [10.1016/j.trf.2019.09.011]

Availability:

This version is available at: 11583/2756172 since: 2019-09-29T10:55:25Z

Publisher:

Elsevier Ltd

Published

DOI:10.1016/j.trf.2019.09.011

Terms of use:

This article is made available under terms and conditions as specified in the corresponding bibliographic description in the repository

Publisher copyright

(Article begins on next page)

What's Around the Curve? A Driving Simulation Experiment on Compensatory Strategies for Safe Driving Along Horizontal Curves with Sight Limitations

Bassani Marco, Hazoor Abrar, Catani Lorenzo

Department of Environment, Land and Infrastructure Engineering, Politecnico di Torino

24 corso Duca degli Abruzzi, 10129 – Torino (Italy)

Abstract

This paper focuses on the behaviours adopted by road users when negotiating horizontal curves with sight limitations. Experiments at a driving simulator were conducted on two-lane highways in which drivers were confronted with a range of sight conditions generated by the manipulation of variables such as curve direction, radii and distance of lateral sight obstructions along horizontal curves. It was observed that most of the drivers adopted strategies which resulted in a stopping distance shorter than the available sight distance, thereby maintaining safe driving conditions. Some drivers reduced their speed, some increased the lateral distance from any sight obstructions along the roadside, some did both, while others did neither. A preliminary analysis indicated that the safety benefits resulting from a vehicle speed reduction strategy significantly outweigh those from a lateral shift in the lane. Further analyses on the 1,246 cases investigated offered further support for this proposition, while revealing that a higher proportion of drivers opted for the first strategy for safety reasons. Moreover, visibility conditions (safe, partially safe, and unsafe) played a role in the choice of driving strategies. Results provide evidence that a significant group of drivers used the two strategies under severely restricted visibility conditions (i.e., along sharp radius curves); however, the strategies selected were independent of the driver speed profile (i.e., slower, average, or faster).

Keywords: road curve design; available sight distance; stopping sight distance; perceived risk; driver profile.

Re-submitted to Transportation Research part F: Traffic Psychology and Behaviour.

1. INTRODUCTION

The theory of risk compensation states that people adjust their behaviour in response to the level of perceived risk (Wilde, 1982). Wilde (1994, 2001) suggested that this adjustment arises from an unconscious and continuous process of evaluation of both risk and safety utility functions. In driving operations, risk compensation is related to the “behavioural adaptation” of drivers to changes in the road that are deemed unfavourable in terms of safety (OECD, 1990). Most changes typically occur in the transition between straights and curves where the driver needs to evaluate certain geometric factors (i.e., lane width, alignment curvature, lateral sight obstruction) before adapting his/her speed (longitudinal) and steering (transversal) behaviour to the new conditions (McDonald, 2004; Coutton-Jean et al., 2009).

Statistics confirm that crashes are more likely to occur along horizontal curves than straight sections (NHTSA, 2008). Comte et al. (2000) reported that a significant proportion of such crashes were most likely caused by drivers travelling too fast while negotiating a curve and losing control of the vehicle or being forced into a skid. Charlton (2007) sustains that crashes along curves are caused by (i) an inability to meet increased attentional demands, (ii) the misperceptions of speed and curvature, and (iii) a failure to maintain the correct lane position. However, there are several elements in the road environment which encourage drivers to adopt optimal behaviours with adjustments to both speed and lateral position in the lane (Reymond et al., 2001; Charlton, 2007). Awan et al. (2019) and Charlton et al. (2018) investigated the impact of perceptual countermeasures on driving behaviour on curves, concluding that additional road markings boost driver attention and improve compliance with posted speed limits, thus resulting in fewer crashes. Curve features affect driver road perception (Charlton et al., 2014). The alignment characteristics (both horizontal and vertical), and the layout of the cross section are significant perceptual factors. In simulated environments, Bella (2014) investigated the effects of combined (horizontal and vertical) curves on driver speed, while Ben-Bassat & Shinar (2011) examined the role of shoulder width and safety barriers on driver behaviour. In both cases, outcomes (speed and lateral position) were significantly influenced by road geometry. Calvi (2015) investigated the effects of some geometric factors on driving performance on 72 different curves distributed across three test scenarios. He concluded that the curve radius, the presence of spirals, the cross-section, and the visibility conditions significantly influenced driving speeds and trajectories.

From the 207 responses provided by Greek drivers to a questionnaire, Kanellaidis (1995) observed that sight distance is one of a number of factors influencing driver speed choice along curves. This is confirmed by Moreno et al. (2013), who stated that a sufficient sight distance value allows

drivers the time to take in the visual information needed to perform any control and guidance actions with a certain margin of safety.

Finally, Weller (2009) observed that a reduction in the sight distance available leads to a reduction in speed along curves similar in magnitude to that produced by the erection of curve warning signs. Weller concluded that any actions which resulted in an increase in perceived risk (sight distance limitation or warning sign), would lead to a reduction in average operating speeds and, consequently, an increase in safety.

Although the effects of restricted and unrestricted sight conditions (Calvi et al., 2015) and the relationship between ASD (Bassani et al., 2019) and speed and lateral shift have already been investigated, the compensatory behavioural adaptation to poor sight conditions and an analysis focusing specifically on the road variables affecting this adapted behaviour have yet to be investigated.

When negotiating a curve with limited visibility, the risk perceived is due to the unknown conditions along that part of the curve not visible to the driver. A line of stopped or slowly moving vehicles, a non-surmountable obstacle in the lane (i.e., a tree, a mass of rock, a stray animal, etc.) may be in that non-visible stretch of curve. In the event one of those obstacles were too close to the actual vehicle position, the driver might not be able to stop the car in time. Hence, such sight conditions are commonly perceived as inherently risky due to the potential presence of unknown obstacles ahead. This is even more likely when drivers operate at high speeds. Drivers know well that the length of road required to bring their vehicle to a halt (i.e., the stopping distance) affects the safety of their journey.

The above reported considerations form part of all updated road design policies to guarantee comfortable and safe travels (AASHTO, 2011; MIT, 2001). Policies define the available sight distance (ASD) as the longest distance that the driver can see along the future vehicle path. Figure 1 exhibits the “conventional” available sight distance (ASD_c) that separates the driver and the target, i.e., the farthest point visible along the lane centreline, which in turn corresponds to the future vehicle trajectory. Another important hypothesis assumed in these policies is that the driver is isolated (i.e., no other vehicles around) and travelling with good visibility on a wet pavement, so as to evaluate the least safe interaction between the driver, the vehicle, the road, and the environment.

For curve analysis and design, ASD_c should be of a sufficient length to enable the driver traveling at the design speed to see an unsurmountable object ahead and make an emergency stop (i.e., the conventional “stopping sight distance”, SSD_c), so as to avoid hitting it. As a result, policies require analysis and, possibly, design corrections aimed at ensuring that $ASD_c \geq SSD_c$ (AASHTO, 2011; MIT, 2001). In the modern approach to roadway design, sight analysis is considered of fundamental importance in the assessment of safety conditions both along road sections and at intersections. Since

2002, in Italy sight analysis has been compulsory in new road planning; the standard requires as an output the ASD_c and SSD_c profiles with the road stations along the abscissa.

With a few adjustments, the visibility concept outlined in the design policies can be transferred to real driving conditions. For example, along a curve the driver line of sight is different from the conventional one, and their operating speed is different from the design one. As a result, the actual available sight distance (ASD_a) may be larger or smaller than ASD_c because of the lateral position of the driver in the lane (Figure 1). Similarly, the actual operating speed may differ from the design speed; consequently, the actual stopping distance (SSD_a) may be different from the conventional (design) one. Since they do not know the exact distance required for a complete emergency stop, when the ASD_a is perceived to be inadequate, drivers can only compensate for the risk associated with unsafe conditions ($ASD_a < SSD_a$) by:

- reducing their speed to reduce SSD_a , and/or
- move laterally in the lane increasing the distance from the sight obstruction to increase ASD_a (evidence for this last proposition is given in Figure 1).

The aim of this study is to investigate if, how, and which drivers employ the following two possible compensatory strategies to maintain safe driving along curves with sight limitations: (i) a decrease in operating speed to reduce the SSD_a , and (ii) a lateral shift of the vehicle in the lane to increase the ASD_a . Experiments at a driving simulator were carried out with the involvement of forty-one volunteers.

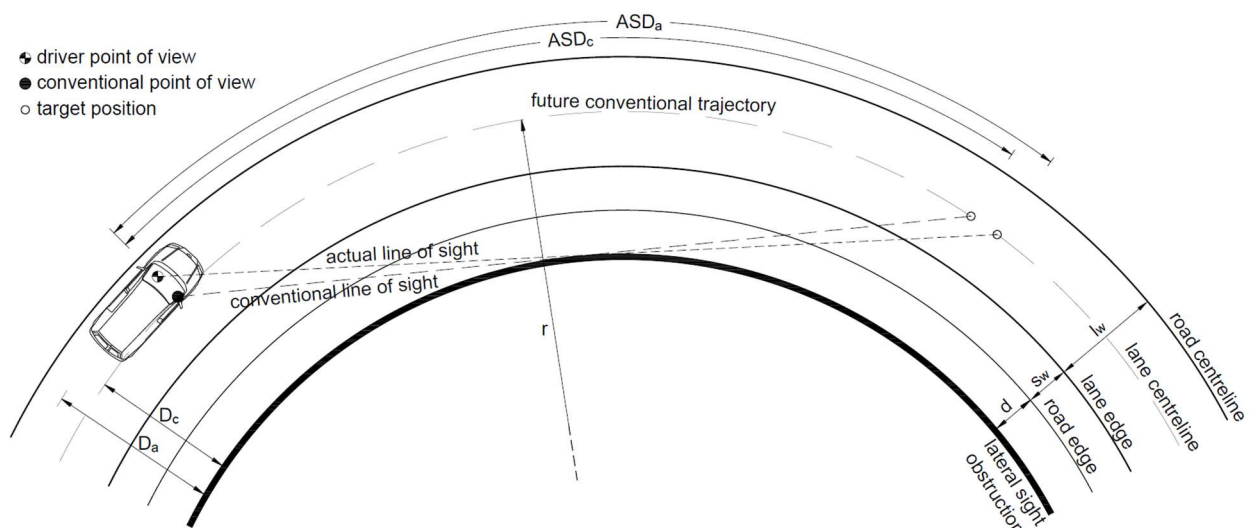

Figure 1. Conventional (ASD_c) and actual (ASD_a) available sight distances along a horizontal curve with sight limitations due to the presence of a lateral sight obstruction. In the figure, r is the radius of the future conventional trajectory; D_c is the conventional offset of the sight obstruction from the ideal trajectory; D_a is the distance between the sight obstruction and the actual trajectory followed by the driver in the vehicle; d is the offset of the lateral sight obstruction from the shoulder; s_w is the shoulder width, l_w is the lane width. The case presented here shows that if the driver is placed at a $D_a > D_c$, then $ASD_a > ASD_c$.

Each of the 1,246 observations collected during the experiment (resulting from a combination of the travelled curves with the drivers involved) were classified under safe (when $ASD_a > SSD_a$ always), partially-safe (when $ASD_a > SSD_a$ for a limited length of the curved road section), and unsafe (when $ASD_a < SSD_a$ along the whole section). The recorded speeds were used to distinguish between slower, average, and faster drivers. The compensation strategies adopted were compared with behavioural profiles, curve radius values, and visibility conditions to determine possible relationships. Finally, an ANOVA was carried out to understand whether road geometric factors could have had an influence on the variations in SSD_a and ASD_a observed from an analysis of experimental speed and position data.

2. METHODOLOGY

In this study, experiments were conducted with the fixed-base driving simulator of the Department of Environment, Land and Infrastructure Engineering at the Politecnico di Torino. The following section outlines the work carried out and the methodologies adopted to accomplish the research objectives.

2.1 PARTICIPANTS

In conformity with the Code of Ethics of the World Medical Association (Williams, 2008), forty-one drivers took part in the experiment on a voluntary basis (26 males and 15 females); they received no benefit or payment for their involvement. All participants signed an informed consent form before the experimental session.

The participant's ages ranged from 20 to 60 years, with a mean age of 34.2 years; the average length of driving experience for the group was 15.2 years, as listed in Table 1. An effort was made to ensure that the group of participants reflected the characteristics of the more active Italian driving population (MIT, 2016). The crash experience data reported in Table 1 indicates that female drivers had a lower number of crashes than males which is consistent with Italian crash statistics (ACI-ISTAT, 2018).

The speed data for each driver along the driven tracks were analysed to define their profile. "Slower" drivers were considered those who maintained a constant vehicle speed below the mean speed (of all collected speed data measured along the track); "average" drivers were those whose speed varied around the mean speed; "faster" drivers were those whose operating speed always exceeded the mean. From the speed profiles in Table 1 we can see that females generally drove slower than males. Finally, in Table 1, drivers are also grouped into three age classes: (i) 20-30, (ii) 31-50, and (iii) 51-60 years old.

Table 1. Characteristics of participants.

Gender	-	Male	Female	Total
Participants (number)	-	26	15	41
Age [years]	Min	20	21	20
	Mean	36.3	30.6	34.2
	Max	60	54	60
Class Age (number)	20-30 (1)	12	11	23
	31-50 (2)	9	3	12
	51-60 (3)	5	1	6
Driving experience [years]	Mean	17.3	11.7	15.2
	Std. Dev.	11.5	10.0	11.2
Crash Experience [frequency/driver]	Mean	1.1	0.5	0.9
	Std. Dev.	1.5	0.5	1.2
Driver profile (number)	Slower	5	8	13
	Average	12	3	15
	Faster	9	4	13

2.2 APPARATUS

A fixed-base driving simulator with force-feedback steering wheel, manual gearbox, pedals, dashboard, and adjustable seat was employed for the experiments. The simulated environment was reproduced by means of three 32-inch sized screens with resolution of 1920×1080 pixel and a frequency of 60 Hz, which covers 130° of the horizontal field of view. A speedometer was built into a dashboard placed behind the steering wheel, while a 5.1 surrounding sound system provides realistic car engine and other environmental noises. *SCANerTMstudio* software was used to develop the experimental tracks, model the scenarios, and run the simulations. A relative validation for speed (Catani, 2019; Bassani et al., 2018) and for trajectories (Catani and Bassani, 2019) was obtained prior to the investigation.

2.3 EXPERIMENTAL DESIGN

Two flat terrain road alignments used in this study were designed according to Italian Geometric Design Standards for highways and streets (MIT, 2001). A two-lane road section having a lane width (l_w) of 3.75 m and a shoulder width (s_w) of 1.5 m was considered. Combinations of four different curve radii (120 m, 225 m, 300 m, and 430 m) were included in the two tracks in random order. To obtain specific ASD values at each curve, a lateral sight obstruction consisting of a 1.5 m high stone wall along the inner side of the horizontal curves was included. The sight obstruction was placed at three different distances ($d_1 = 0$ m, $d_2 = 1.5$ m, and $d_3 = 3$ m) from the inner pavement edge. For confounding purposes, other curves had unrestricted sight conditions (i.e., with no sight obstructions), and corresponding data were not analysed in this work. Each alignment was composed of 18 horizontal curves, the parameters of which were manipulated by combining curve radii (r) and sight obstruction wall distances (d) from the road edge, as illustrated in Figure 2.

For each combination of successive horizontal curves, a straight segment was included to prevent the driver's performance along a curve being influenced by previous curves. Assuming the prescription of the Italian Road Geometrics Policy, the length of tangent section was set in a 110 to 300 m range (MIT, 2001). Furthermore, the horizontal curves and tangents were properly connected with transition curves (spirals) with a parameter scale ranging from $r/3$ to r in compliance with the optical criterion for transition curve design (MIT, 2001).

The lengths of the two alignments were equal to 12.89 km and 14.44 km. Considering the possibility of simulator sickness, fatigue and boredom, the track lengths were designed to limit drive times to 20 minutes (Philip et al., 2003).

In this experiment, a simulated passenger car having a 130 HP engine with a six-gear manual transmission was selected. The tracks were driven in both directions (clockwise and anti-clockwise) to gather data on both left- and right-hand similar curves. Random traffic was simulated in both travelling directions, paying attention not to influence driver behaviour, in order to gather the desired speed and trajectory data based only on the road environment. The presence of preceding cars on the travelled lane was designed to induce the suspicion of potential obstacles in the lane: they were placed sufficiently ahead of the simulated vehicles to avoid the need to overtake them. Thus, free-flow conditions in the driven directions were guaranteed in all the experiments. Finally, no vertical signs and other constraints were included along the tracks.

Prior to starting the experiments, participants familiarized themselves with the simulator by driving a simple scenario for about 10 minutes (Rizzo et al., 2001). Each participant drove two random pre-selected tracks with a rest of at least 10 minutes in between to re-establish optimal driving performance (Cobb et al., 1999).

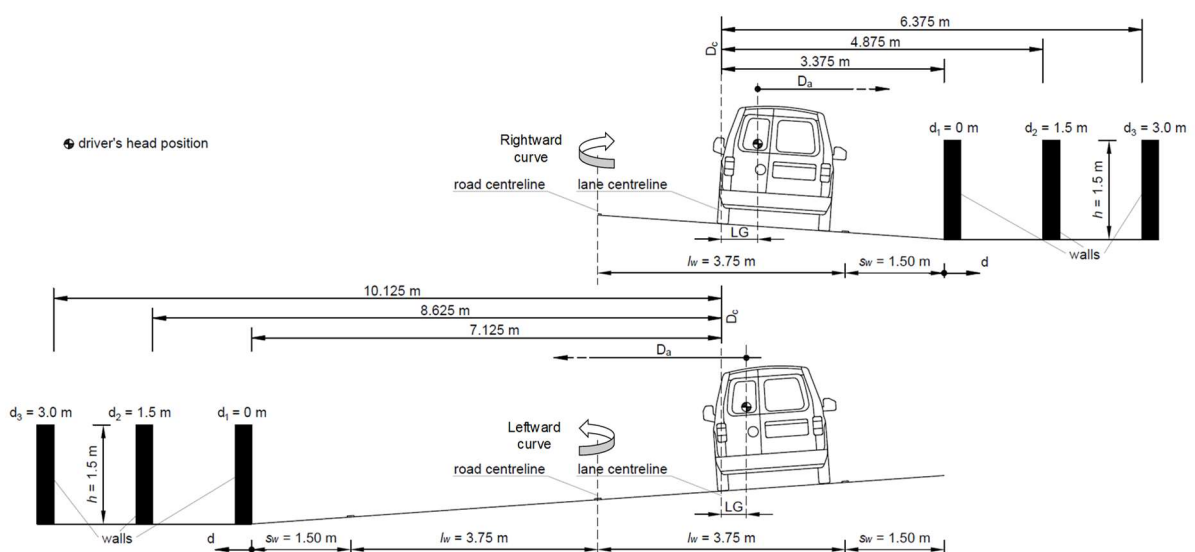

Figure 2. Cross section of the road configuration in right-hand and left-hand curves, with the sight obstruction at different distances from the lane axis (D_c) and from the driver's line of sight (D_a). The lane gap (LG) measures the distance from the driver to the lane centreline.

2.4 DRIVING SIMULATOR DATA COLLECTION

Vehicle speed (v) and position in the lane (LG) measured from the lane centreline (Figure 2) were the parameters considered in this study. These data were extracted for each driver along the investigated curves, as well as along the approaching and leaving sections (spirals and tangents), as shown in Figure 3. The same data were used to compute the sight distances according to the methodologies reported in the next sections.

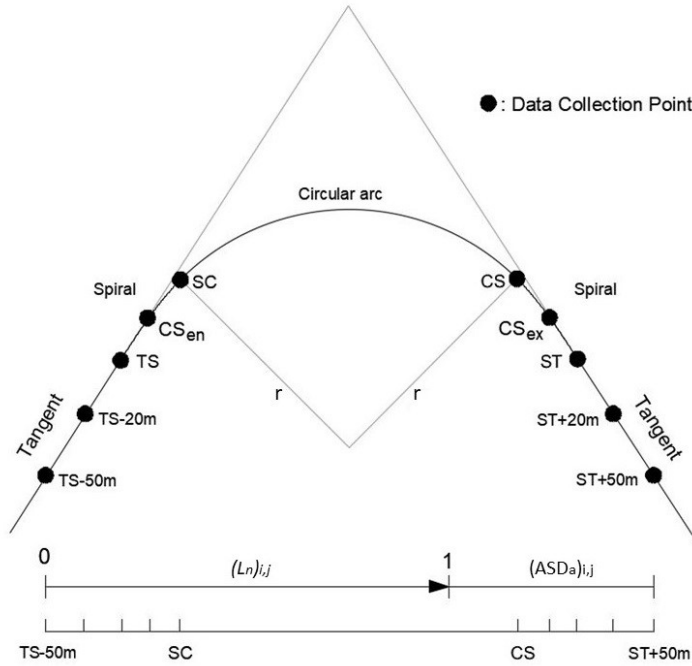

Figure 3. Spiralled design horizontal curve with data reference points (Notes: SC = Spiral to Curve point; CS = Curve to Spiral point; TS = Tangent to Spiral point; ST = Spiral to Tangent point; CS_{en} = Centre of entry Spiral point; CS_{ex} = Centre of exit Spiral point; $(L_n)_{i,j}$ = normalized length for i -th curve and j -th driver; $(ASD_a)_{i,j}$ = actual available sight distance on the final target point placed at ST+50 m).

2.4.1 Stopping sight distance

An accurate evaluation of SSD_a is only possible when the driver makes an emergency stop. Therefore, it is not possible in practical terms to measure such a variable. To overcome this problem, the $(SSD_a)_{i,j}$ values for the i -th curve travelled by the j -th driver were estimated by referring to:

$$(SSD_a)_{i,j} = (v_a)_{i,j} \cdot \tau + \frac{[(v_a)_{i,j}]^2}{2g \cdot (f_e \pm i)} \quad (1)$$

which derive from the equilibrium of forces acting on a vehicle (according to Newton's second law) and considering the perception and reaction time. It gives a measure of the most probable distance required for a complete stop. In eq. 1, v_a is the observed vehicle speed at reference points in m/s, τ is the perception-reaction time in s, that was assumed equal to $(2.8 - 0.01 \cdot V_a)$ with V_a expressed in km/h

according to the Italian standard (MIT, 2001), f_e is the equivalent longitudinal friction coefficient (values provided by the same Italian standard), i is the longitudinal grade of road, and g is the gravitational acceleration.

For this experiment, eq. 1 provided the $(SSD_a)_{i,j}$ values on the basis of conditions assumed by the Italian standards (MIT, 2001), which may differ from the real ones. For example, the perception-reaction time (τ) varies between drivers, and indeed also for the individual driver when he/she operates under different health, attentional, and environmental conditions (Lerner, 1993; Green, 2000; Layton and Dixon, 2012). Moreover, the equivalent longitudinal friction coefficient (f_e), which includes the contribution of aerodynamic drag force and rolling resistance to the stopping distance, is highly dependent on speed, as well as on tire, vehicle, and road surface conditions (e.g., new/old tire tread, wet/dry pavement surface). Both values cannot be precisely reckoned for the experimental conditions investigated here, but they approximate to possible values of $(SSD_a)_{i,j}$ which were compared with the actual estimation of $(ASD_a)_{i,j}$ during the experiments.

2.4.2 Available sight distance

When both the driver and the target are positioned along the circular portion of the curve (i.e. between SC and CS in Figure 3), as illustrated in Figure 1, $(ASD_c)_i$ and $(ASD_a)_{i,j}$ are computed as follows:

$$(ASD_c)_i = 2(r_c)_i \cdot \arccos \left[1 - \frac{(D_c)_i}{(r_c)_i} \right] \quad (2)$$

$$(ASD_a)_{i,j} = 2(r_a)_{i,j} \cdot \arccos \left[1 - \frac{(D_a)_{i,j}}{(r_a)_{i,j}} \right] \quad (3)$$

where $(ASD_a)_{i,j}$ was obtained by considering the average trajectory of the j -th driver along the i -th curve, $(r_a)_{i,j}$ was calculated as the radius of this average actual trajectory, and D_a was computed following the scheme of Figure 2; $(ASD_c)_i$ simply depends on $(r_c)_i$ and $(D_c)_i$ of the i -th curve only (i.e., it is independent of the driver).

When either of or both the driver and the target fell outside the circular arc (before SC and/or after CS in Figure 3), ASD_c and ASD_a values were estimated on the basis of the known geometrical features of the curves as per the methodology outlined in the Appendix.

2.4.3 Visibility conditions

Subsequently, $(ASD_a)_{i,j}$ and $(SSD_a)_{i,j}$ values were compared to analyse the actual visibility conditions along the driven path of each individual test driver.

The visibility conditions along the track were investigated by developing $(i \times j)$ sight profiles. Looking at the visibility profile examples shown in Figure 4, ASD_a changes with the decrease in sight

distance as the vehicle approaches the curve with a lateral sight obstruction. The lowest value of ASD_a is reached when the vehicle and target point (the farthest point visible along the future trajectory) are both inside the circular arc (eq. 3 was used to validate the values obtained from the analysis). In contrast, SSD_a depends on the adopted speed; hence it can increase, decrease or remain constant depending on driver longitudinal behaviour. According to Figure 4, the three examples lead to the following three sight conditions:

- “safe”, when $(ASD_a)_{i,j} > (SSD_a)_{i,j}$ throughout the profile (approaching and exiting the curve);
- “partially-safe”, when $(ASD_a)_{i,j} > (SSD_a)_{i,j}$ for a limited part of the driven path approaching and exiting the curve; and
- “unsafe”, when $(ASD_a)_{i,j} < (SSD_a)_{i,j}$ throughout the profile.

It is worth noting that in Figure 4, the horizontal axis indicates the position of a vehicle as a function of the normalized length starting from the first reference point (TS – 50 m, $L_n = 0$) to the final point (when the target at the end of the line of sight meets the ST + 50 m, it represents the position of the driver, $L_n = 1$).

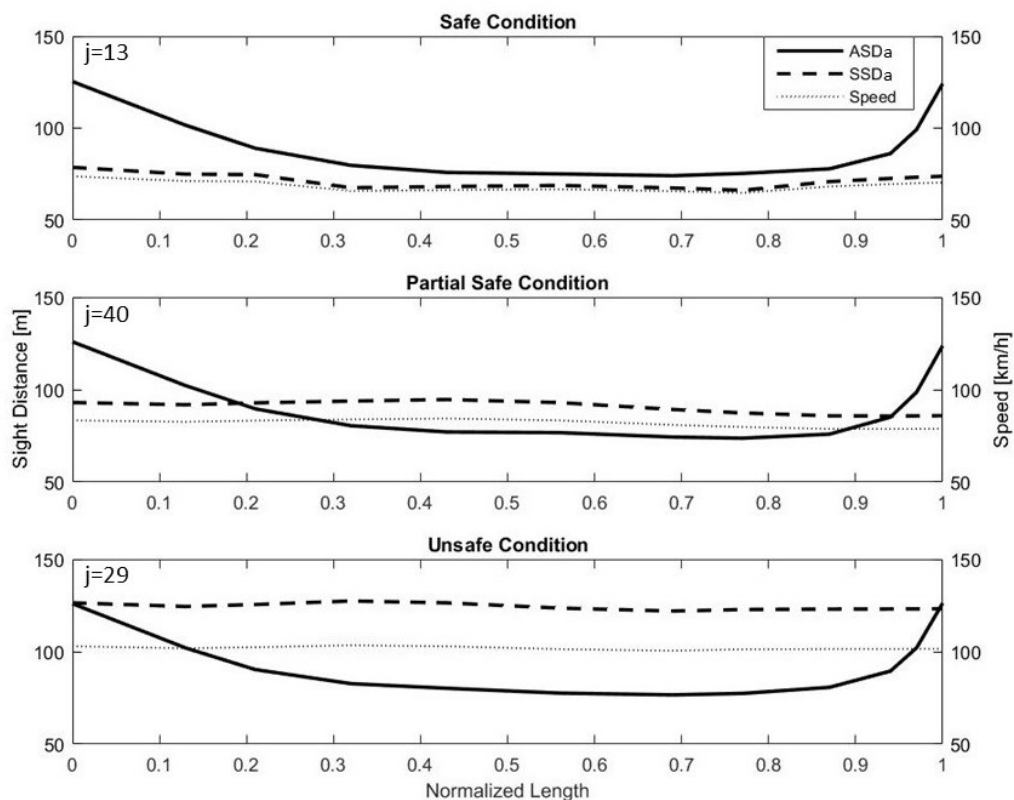

Figure 4. Comparison of actual available (ASD_a) and stopping sight (SSD_a) distances and actual speed profiles. Examples from three different test drivers (j) along the same rightward curve ($i = 10$) having $r = 120$ m, $D = 6.375$ m, and $d = 3$ m.

Since drivers are not aware of the actual values of available and stopping sight distances, they must rely on their previous driving experience to support any evaluations regarding same. Hence, drivers who feel unsafe adjust their speed and/or position in the lane in response to the limited sight conditions and the associated perceived risk, while those who feel safe do not make any adjustments, thus maintaining and accepting the perceived risk level.

2.5 COMPENSATORY STRATEGIES

As previously stated, the only two compensatory strategies that may be adopted to increase the margin of safety along curves with limited visibility are (1) a reduction in the SSD by decreasing the operating speed along the curve, and (2) a lateral shift of the vehicle in the lane to increase ASD_o .

The SSD variation, namely $\Delta(SSD_a)_{i,j}$, was determined for the first strategy with the help of:

$$\Delta(SSD_a)_{i,j} = (SSD_{a,SC})_{i,j} - (SSD_{a,CS})_{i,j} \quad (4)$$

where $(SSD_{a,SC})_{i,j}$ is the actual stopping sight distance of the i -th curve at the SC point of the j -th driver, while $(SSD_{a,CS})_{i,j}$ is the same value at the CS point (Figure 3). Positive values for $\Delta(SSD_a)_{i,j}$ indicate that the driver reduced speed (with positive speed variations, Δv_o) to shorten the SSD in an attempt to increase the margin of safety (i.e., decreasing the perceived risk in negotiating the curve), otherwise the driver did not compensate for a perceived unsafe condition (with null or negative Δv_o).

The values of ASD, namely $(ASD_a)_{i,j}$, were estimated according to the methodology presented in Section 2.4.2; the ASD variation ($\Delta ASD_{i,j}$) with respect to the conventional position was estimated as per the following equation:

$$\Delta ASD_{i,j} = (ASD_a)_{i,j} - ASD_{c,i} \quad (5)$$

Positive $\Delta ASD_{i,j}$ values indicate that the driver benefited from sight distance values higher than the conventional one. In these circumstances, the i -th driver increased the margin of safety by shifting the vehicle laterally away from the sight obstruction (thus introducing a variation in the lateral distance from said obstruction ΔD_o). Conversely, negative $\Delta ASD_{i,j}$ values indicate a lateral shift towards the sight obstruction (interior side).

Speed and lane position profiles relative to 1,246 curves were analysed in this work from a total of 1,476 data (resulting from the combination of 41 drivers \times 18 curves \times 2 tracks) collected in the experiment. As already mentioned, curves with unrestricted sight conditions

(14 drivers × 6 curves × 2 tracks) were excluded, as well as those curves where drivers were conditioned by vehicles ahead (a total of 62 cases were observed).

3. RESULTS AND DISCUSSION

Observations confirmed that some drivers moved laterally thereby changing D_a to increase ASD_a , others reduced speed (v_a) along the curve thereby reducing SSD_a , some moved laterally and reduced speed at the same time, while a group of drivers did not make any changes aimed at improving safety.

The minimum, the mean, the maximum, and the standard deviation of estimated values for the two compensatory strategies are summarized in Table 2. Data in the table present positive and negative values demonstrating that some drivers compensated for the hazardous sight conditions, while others did not. Regarding the magnitude of values, it is worth noting that ΔASD_{ij} and ΔD_a values fall within a smaller range than $\Delta(SSD_a)_{ij}$ and Δv_a . This fact evidences that, for the investigated range in the geometry of curves, drivers reaped greater benefits when they reduced their speed than when they moved laterally in the lane.

Table 2. Summary of estimated magnitude of compensatory strategies at different radii (r). The sign conventions for Δv_a and ΔD_a are: (+) = reduction in speed/ away from the sight obstruction; (-) = increase in speed/towards the sight obstruction; the sign convention for $\Delta(SSD_a)_{ij}$ and ΔASD_{ij} are: (+) = increase of distance; (-) = decrease of distance. Number of observations are: 318 for 120 m, 308 for 225 m, 336 for 300 m, and 284 data for 430 m, with a total of 1,246 data.

Compensatory strategy	Parameter	Radius [m]	Min	Mean	Max	Std. Dev.
Speed reduction	Δv_a [km/h]	120	-12.33	3.36	21.26	5.1
		225	-25.65	-2.92	19.79	9.0
		300	-24.57	-1.29	23.11	9.8
		430	-22.03	-6.12	24.62	9.4
		All cases	-25.65	-1.7	24.62	10.5
	$\Delta(SSD_a)_{ij}$ [m]	120	-13.4	5.8	34.9	7.7
		225	-44.6	-3.4	35.2	10.6
		300	-42.6	-2.0	39.3	12.3
		430	-50.7	-8.6	52.9	14.5
		All cases	-50.7	-1.9	52.9	12.6
Lateral shift	ΔD_a [m]	120	-2.3	-0.5	0.9	0.5
		225	-1.7	-0.4	0.7	0.4
		300	-1.3	-0.3	0.8	0.4
		430	-1.5	-0.3	0.8	0.4
		All cases	-2.3	-0.4	0.9	0.6
	ΔASD_{ij} [m]	120	-6.1	-1.5	2.8	1.5
		225	-6.4	-1.7	3.2	1.7
		300	-6.0	-1.5	5.1	2.0
		430	-7.3	-1.5	4.4	2.3
		All cases	-7.3	-1.5	5.1	1.9

3.1 DRIVER PROFILES AND AGE CLASS VS. VISIBILITY CONDITIONS

The relationship between the visibility conditions and the driver behaviour profiles and age classes are synthesized in Figure 5. Consistent with Table 1, participants were almost equally distributed across the three profiles (33.9, 37.1, and 29.0% for slower, average, and faster drivers respectively).

Figure 5a summarises the distribution of the three driver behaviour profiles with respect to the three driving conditions established in Section 2.4.3. A sizeable majority of drivers operated under safe visibility conditions (711 out of 1,246, 57.1%), while only 5.5% of drivers drove the simulated vehicle under unsafe conditions. The results in Figure 5a are evidently in line with expectations: in 358 out of 422 cases (84.8% of data), slower drivers operated in safe visibility conditions, while in just one case (i.e., one driver on one curve) a slower driver was observed operating in unsafe conditions. Conversely, in 282 out of 362 cases (77.9% of data) faster participants drove in partially or totally unsafe conditions.

The data in Figure 5b show a similar trend to those in Figure 5a, when age classes are substituted for driver profiles. In the case of the more experienced drivers involved in the experiment (Class Age 3, 51-60 year olds), many (104 out of 174) drivers operated in partially or totally unsafe conditions, while the majority of drivers in the two younger age classes drove safely (417 out of 702 in Class Age 1, 224 out of 370 in Class Age 2). This result reflects the tendency of inexperienced drivers to adopt a safer approach to curves with sight constraints compared to more experienced drivers. In other words, the latter have more confidence in their ability to negotiate risky road conditions, or analogously they perceive a lower level of risk than young drivers when exposed to the same sight limitations.

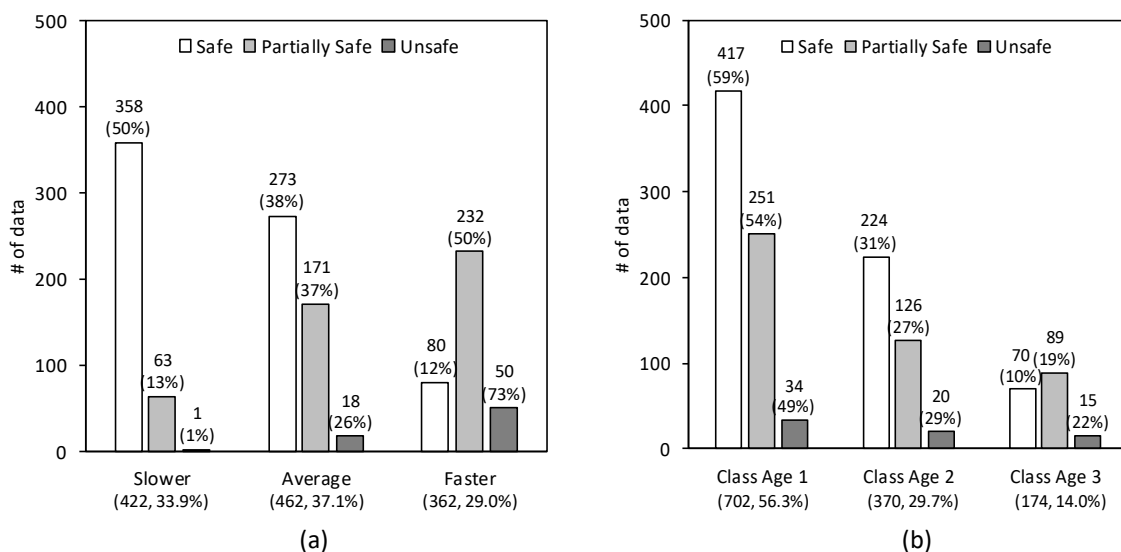

Figure 5. (a) Frequency of driver profile type against the visibility conditions; (b) frequency of Class Age against the visibility conditions.

3.2 COMPENSATORY STRATEGIES VS. VISIBILITY CONDITIONS

Figure 6 provides a summary of the data indicating the numbers and percentages of drivers who used compensatory strategies under the different visibility conditions (i.e., safe, partially safe and unsafe). Under safe conditions, around 85% of 711 drivers did not shift their vehicle laterally, while in around 32% of 69 cases a lateral shift was used to compensate for a perceived unsafe sight condition (Figure 6b).

In unsafe sight conditions, around 75% of 69 drivers compensated with a speed reduction, while in safe conditions, around 60% of drivers did not reduce their speed. These results add further support to the explanations given in Section 3.1, thus reinforcing the hypothesis that the marked tendency to reduce speed to compensate for a lack of visibility is linked to the greater benefits that can be obtained in comparison to those gained from a lateral shift.

In a different analysis, data was broken down into four cases considering the possible combined use of the two compensatory strategies (Figure 7). The first case includes data where positive values for both $\Delta(SSD_a)_{i,j}$ and $\Delta ASD_{i,j}$ were observed and consists of a number of cases in which participants employed both compensatory mechanisms in curve negotiation. A second and third case refer to those drivers who adopted only one of the two strategies. The fourth case includes data with negative values for $\Delta(SSD_a)_{i,j}$ and $\Delta ASD_{i,j}$ reflecting situations in which drivers did not adopt any compensation strategies.

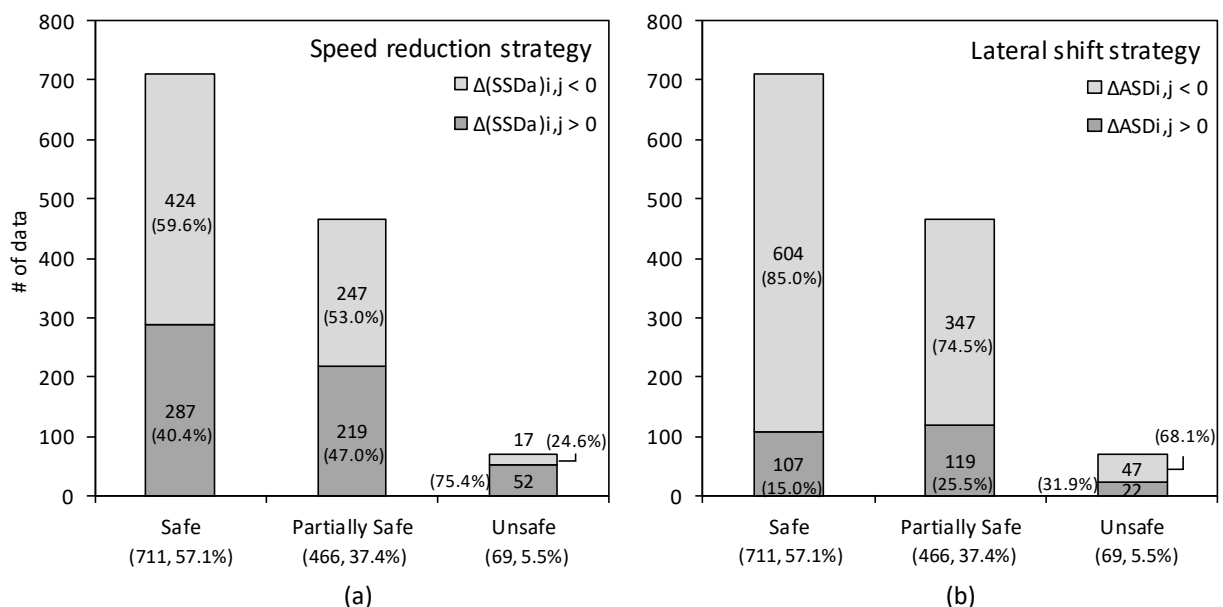

Figure 6. Number of times (in absolute and percentage terms) in which curves were negotiated with (a) a speed reduction, and (b) a lateral shift, for different visibility conditions.

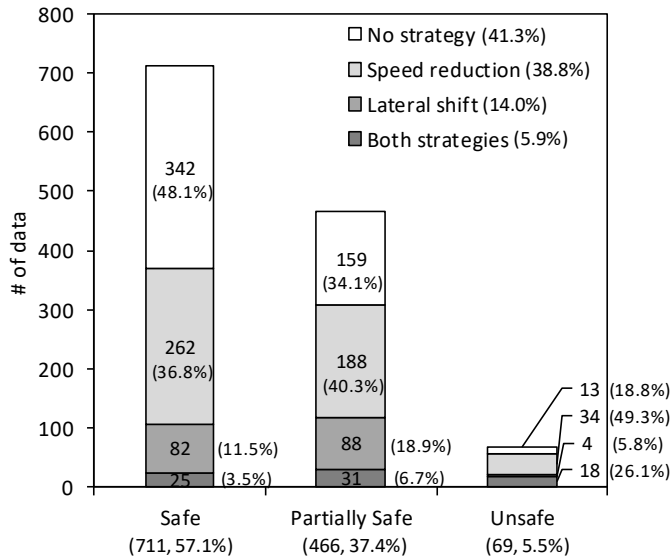

Figure 7. Driver choice of compensatory strategy combinations considering visibility profile type.

342 out of 711 (48.1%) drivers operating under safe visibility conditions did not perform any compensatory manoeuvre, together with 172 out of 535 (13.8%) operating under unsafe and partially safe conditions. 369 (29.6%) drivers operating under safe conditions adopted a compensatory strategy, along with 363 out of 1,246 (29.1%) drivers operating under unsafe and partially safe conditions.

3.3 COMPENSATORY STRATEGIES VS. DRIVER PROFILE AND AGE CLASS

Figure 8a presents the breakdown of compensatory strategies by driver speed profile (slower, average, and faster) as defined in Section 2.1. No significant differences in adopted strategies in curve negotiation were observed between driver profiles. This result is certainly in part due to the use of a profile classification based on just one single parameter (i.e., speed). According to Meiring and Myburgh (2015), driver behaviour and profiles may be characterised by a multiple of parameters from psychology, ergonomics, and traffic flow theory.

Figure 8b shows the distribution of compensatory strategies as a function of the three age classes. The results are consistent with those reported in Section 3.1 and indicate that more experienced drivers (Class Age 3) tend to be more confident in their driving capabilities. In fact, a larger proportion of them do not adopt any strategy to negotiate curves with sight limitations (84 cases out of 174, 48.2%) when compared to drivers in Class Age 2 (158 cases out of 370, 42.7%) and in Class Age 1 (272 cases out of 702, 38.7%).

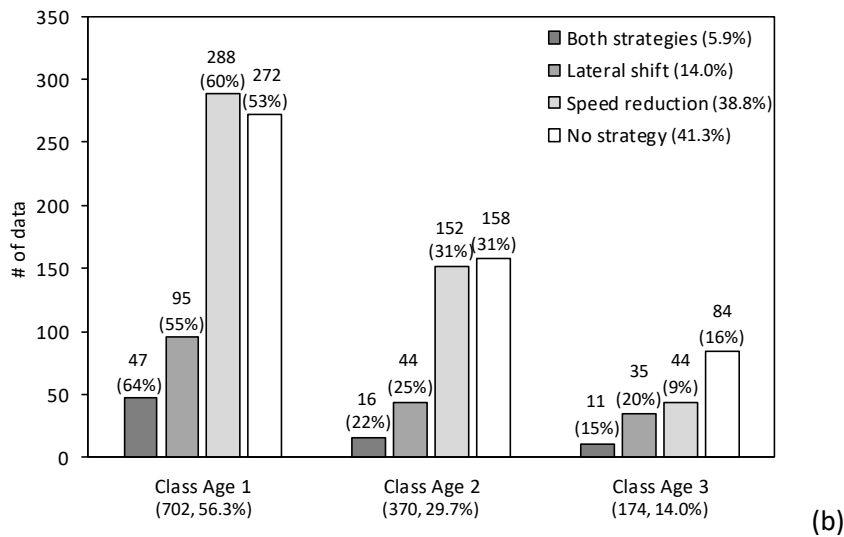
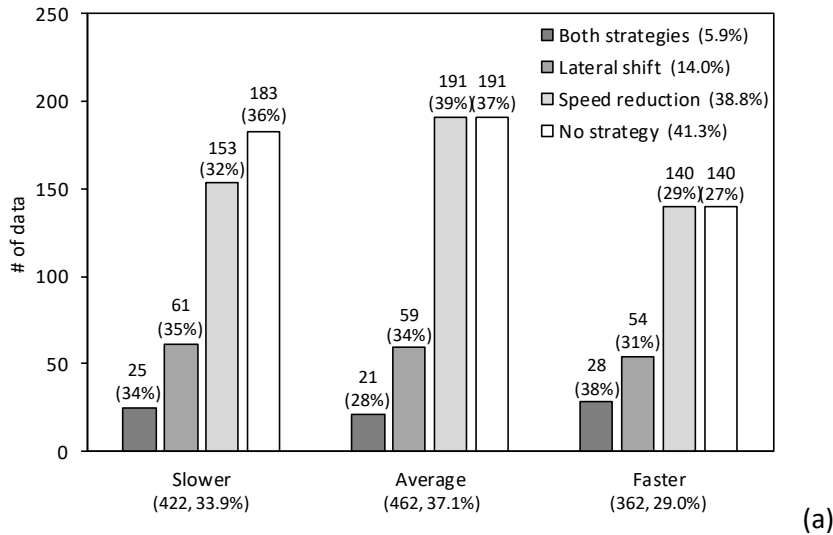

Figure 8. (a) Compensatory strategies associated with driver profile; (b) compensatory strategies associated with driver class age.

3.4 CURVE RADIUS VS. COMPENSATORY STRATEGIES AND VISIBILITY CONDITIONS

Figure 9 shows the relationships between the curve radius and visibility conditions, and the compensatory strategies adopted. The graph in Figure 9a clearly indicates that the curve with the smallest radius (i.e., 120 m) features 64% of drivers operating under unsafe or partially safe conditions. Only with increased radius values did many drivers operate safely, with 75% of drivers driving safely with a radius value of 430 m.

The results in Figure 9b confirm that different strategies were adopted for curves with different radius values. While smaller radii serve to encourage speed reduction strategies (68% of drivers at 120 m), with larger radii some drivers move laterally to benefit from a larger ASD (23% of drivers adopted a lateral movement against 20% of those who only reduced their speed). It is worth noting

that an increase in radius results in an increase in the number of drivers tending to adopt one strategy instead of two (at 430 m, only 2% of drivers adopted both).

These results evidence the different behavioural outputs produced by short radii (sharp) curves with respect to shallow ones, with shallower curves ($r \geq 225$ m) having a different proportions distribution. In the case of the 120 m radius, the majority of drivers operated unsafely, with the result that a higher number of speed reduction operations were performed to compensate for these potentially hazardous sight conditions.

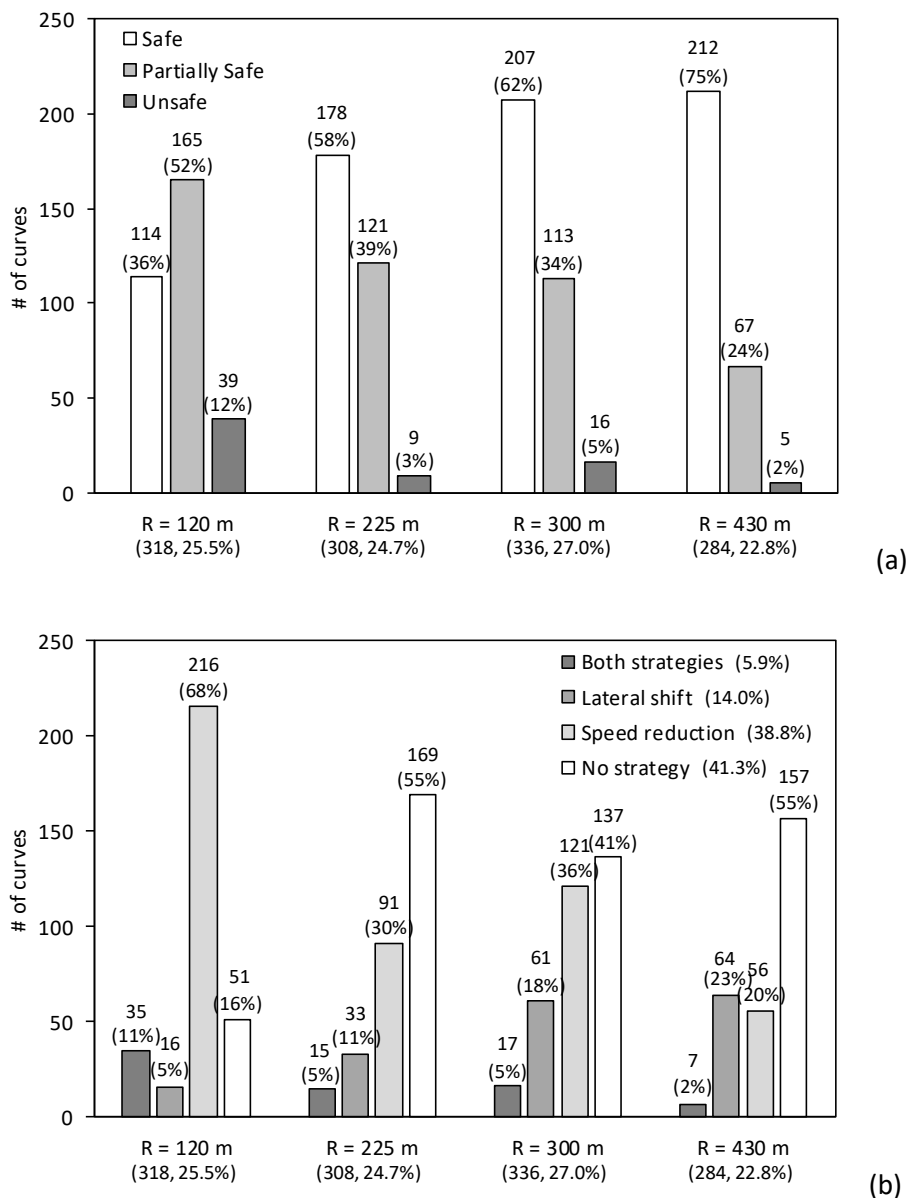

Figure 9. Curve radius values associated with (a) visibility conditions and (b) compensatory strategies.

3.5 FACTORS AFFECTING COMPENSATORY STRATEGIES

An analysis of variance (ANOVA) was performed to determine the impact of road geometric factors on compensatory mechanisms. In this analysis, both dependent measures were analysed separately against the following independent factors depicted in Figure 1: (i) direction of the curve (rightward and leftward), (ii) radius of curvature (120 m, 225 m, 300 m, and 430 m), and (iii) sight obstruction distance from road edge (0, 1.5 m, and 3 m).

Additionally, data were grouped into two families considering the different visibility conditions: in the first group data for safe profiles were included, while the second group contains the partially safe (PS) and unsafe (US) visibility condition data. Therefore, two ANOVAs were conducted per compensatory strategy.

3.5.1 Speed reduction

The effect of road geometry factors on $\Delta(SSD_o)_{i,j}$ are listed in Table 3 for safe conditions, and Table 4 for partially safe and unsafe conditions. In the first case, ANOVA revealed the significance of curve direction ($F(1,687) = 5.72, p < 0.05, \eta^2 = 0.007$), and radius ($F(3,687) = 14.26, p < 0.001, \eta^2 = 0.050$) while the effect of sight obstruction distance was not found to be significant for the speed reduction strategy for the safe profile group. The interaction effect of sight obstruction distance from the roadside (d) with other factors was found to be moderately significant.

In the second case, ANOVA showed the significant effects of both curve direction ($F(1,512) = 34.42, p < 0.001, \eta^2 = 0.044$), and curve radius ($F(3,512) = 35.23, p < 0.001, \eta^2 = 0.053$). As with previous cases, the main effect of sight obstruction distance was not found to be significant for the compensatory strategy, while the interaction between sight obstruction distance and curve direction proved significant ($F(2,512) = 7.14, p < 0.001, \eta^2 = 0.018$), suggesting that the role played by the distance of sight obstruction changes when it is evaluated together with curve direction. No further significant interaction effects were determined in the analysis.

Both analyses revealed that geometric factors play an important role in the adoption of a speed reduction strategy with the radius having the greatest effect ($\eta^2 = 5\%$). The results also confirm the preliminary analysis which highlighted a significant variation in the magnitude of the compensatory strategies $\Delta(SSD_o)$ at different radii (Table 2). Possible reasons for this variation could be the different speeds adopted by drivers when considering the magnitude of curve radius (Calvi, 2015), and the manoeuvre direction, i.e. rightward and leftward (Bella, 2013).

Table 3. ANOVA on factors affecting $\Delta(SSD_a)_{i,j}$ for safe visibility conditions.

(Notes: Dir = Direction, r = Curve Radius, d = sight obstruction distance from road edge)

Source	Partial SS	df	MS	F	Prob > F	η^2
Number of obs.	711					
Root MSE	9.2863					
Model	14541.7	23	632.25	7.33	0.0000	
Main Effects						
<i>Dir</i>	493.6	1	493.6	5.72	0.0170	0.00669
<i>r</i>	3689.6	3	1229.87	14.26	0.0000	0.05001
<i>d</i>	126.2	2	63.11	0.73	0.4814	0.00171
Interaction						
<i>Dir * r</i>	93.5	3	31.18	0.36	0.7808	0.00127
<i>Dir * d</i>	825.0	2	412.48	4.78	0.0086	0.01118
<i>r * d</i>	2275.0	6	379.17	4.40	0.0002	0.03083
<i>Dir * r * d</i>	1552.8	6	258.79	3.00	0.0067	0.02104
Residual	59243.6	687	86.24			
Total	73785.3	710	103.92			

Table 4. ANOVA on factors affecting $\Delta(SSD_a)_{i,j}$ for partially safe and unsafe visibility conditions

(Notes: Dir = Direction, r = Curve Radius, d = sight obstruction distance from road edge)

Source	Partial SS	df	MS	F	Prob > F	η^2
Number of obs.	535					
Root MSE	12.5307					
Model	41973.0	22	1907.86	12.15	0.0000	
Main Effects						
<i>Dir</i>	5404.3	1	5404.26	34.42	0.0000	0.04416
<i>r</i>	6596.6	3	5532.20	35.23	0.0000	0.05391
<i>d</i>	776.6	2	388.30	2.47	0.0853	0.00635
Interaction						
<i>Dir * r</i>	1322.7	3	440.89	2.81	0.0391	0.01081
<i>Dir * d</i>	2242.8	2	1121.38	7.14	0.0009	0.01833
<i>r * d</i>	1943.4	6	323.90	2.06	0.0561	0.01588
<i>Dir * r * d</i>	1443.2	5	288.63	1.84	0.1038	0.01179
Residual	80393.9	512	157.02			
Total	122366.9	534	229.15			

The effects of radius on the choice of compensatory mechanism together with the interaction between this variable and profile type (safe and unsafe) is illustrated in Figure 10a. The results showed that in 79% of all cases with a radius of 120 m participants reduced their speed; these results are in line with those obtained by Calvi (2015) who also found that lower speed is an example of compensatory behaviour in reduced visibility conditions. However, on medium and large radius curves (r equal to 225, 300, and 430 m) drivers tend to increase speed so a higher proportion of $\Delta(SSD_a)_{i,j}$ values are negative which means driver did not compensate with a reduction in speed. The same results were observed with the interaction of radius and curve direction, as shown in Figure 10b.

These results support the Risk Homeostasis Theory, which purports that drivers possess an internal target level of risk for each situation, and they will increase or decrease their safety actions in order to reduce the difference between their momentary perceived level of risk and situational target

level (Wilde, 1982; Lewis-Evans and Charlton, 2006). The perceived risk decreases with an increase in radius values, therefore drivers tend to increase speed in order to maintain the momentary risk level in line with the target one.

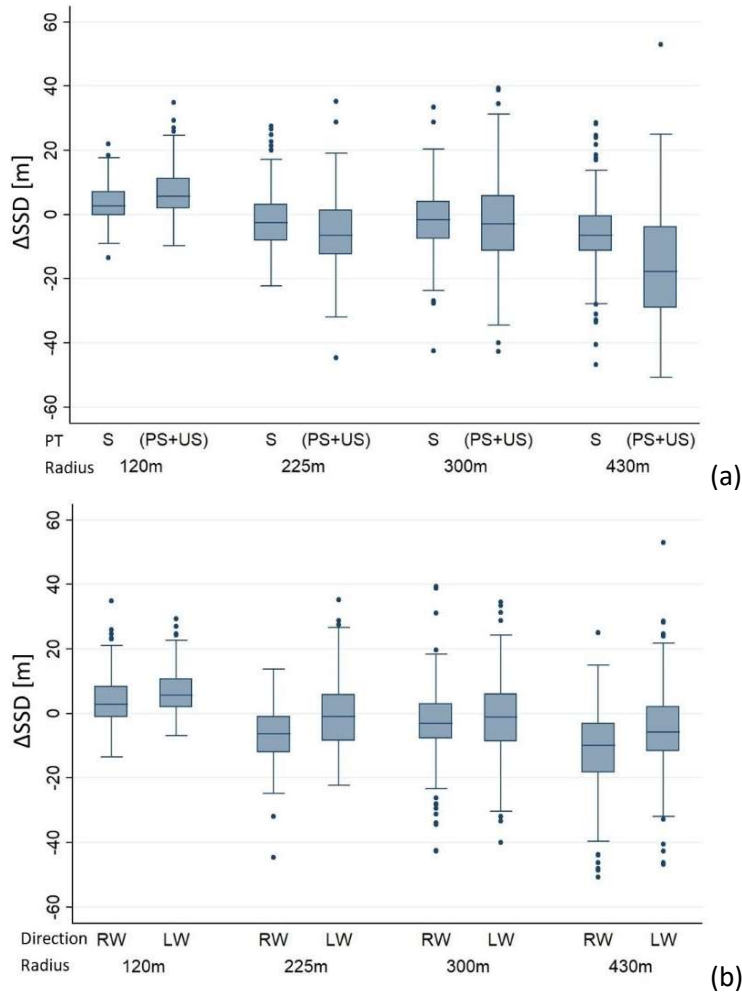

Figure 10. Risk compensation as per the speed reduction strategy: (a) effect of visibility conditions (safe, S; partially safe, PS; unsafe, US) and radius; (b) effect of curve direction (rightward, RW; leftward, LW) and radius.

3.5.2 Lateral shift

Table 5 presents the results of ANOVA for the lateral shift compensatory mechanism (ΔASD) when considering the safe profile group. Results revealed the effects of direction ($F(1,687) = 156.12$, $p < 0.001$, $\eta^2 = 0.149$) and sight obstruction distance (d) to be highly significant ($F(2,687) = 4.09$, $p < 0.001$, $\eta^2 = 0.007$), while the effect of radius (r) is insignificant for the first compensatory mechanism. The analysis of variance shows a significant interaction effect between curve direction and radius ($F(3,687) = 8.04$, $p < 0.001$, $\eta^2 = 0.002$), while the interaction effect between other factors was not significant under safe profile conditions.

The same analysis was performed with the partially safe and unsafe profile groups as listed in Table 6. ANOVA revealed that only curve direction had a significant effect on the dependent

parameter ($F(1,512) = 116.35, p < 0.001, \eta^2 = 0.149$). ANOVA showed a moderate level of interaction between curve direction and sight obstruction distance ($F(2,512) = 7.70, p < 0.001, \eta^2 = 0.019$); and between curve radius and sight obstruction distance ($F(6,512) = 3.21, p < 0.01, \eta^2 = 0.024$).

Table 5. ANOVA on factors affecting ΔASD_{ij} data for safe visibility conditions.

(Notes: Dir = Direction, r = Curve Radius, d = sight obstruction distance from road edge)

Source	Partial SS	df	MS	F	Prob > F	η^2
Number of obs.	711					
Root MSE	1.4547					
Model	754.6	23	32.81	15.50	0.0000	
Main Effects						
<i>Dir</i>	330.4	1	330.35	156.12	0.0000	0.14960
<i>r</i>	4.3	3	1.43	0.67	0.5681	0.00194
<i>D</i>	17.3	2	8.65	4.09	0.0172	0.00784
Interaction						
<i>Dir * r</i>	51.0	3	17.01	8.04	0.0000	0.02311
<i>Dir * d</i>	10.7	2	5.34	2.53	0.0808	0.00484
<i>r * d</i>	11.6	6	1.94	0.92	0.4825	0.00527
<i>Dir * r * d</i>	13.8	6	2.29	1.08	0.3704	0.00623
Residual	1453.8	687	2.12			
Total	2208.3	710	3.11			

Table 6. ANOVA on factors affecting ΔASD_{ij} data for partially safe and unsafe visibility conditions .

(Notes: Dir = Direction, r = Curve Radius, d = sight obstruction distance from road edge)

Source	Partial SS	df	MS	F	Prob > F	η^2
Number of obs.	535					
Root MSE	1.5962					
Model	681.5	22	30.98	12.16	0.0000	
Main Effects						
<i>Dir</i>	296.4	1	296.42	116.35	0.0000	0.14926
<i>r</i>	19.9	3	6.62	2.60	0.0516	0.01000
<i>d</i>	6.1	2	3.03	1.19	0.3050	0.00305
Interaction						
<i>Dir * r</i>	3.7	3	1.24	0.49	0.6905	0.00188
<i>Dir * d</i>	39.2	2	19.62	7.70	0.0005	0.01976
<i>r * d</i>	49.1	6	8.19	3.21	0.0042	0.02474
<i>Dir * r * d</i>	21.7	5	4.35	1.71	0.1314	0.01095
Residual	1304.5	512	2.55			
Total	1985.9	534	3.72			

This analysis shows that only some parameters affect the lateral shift strategy directly, while all of them affect the ΔASD_{ij} when interacting with other variables. The contribution of curve direction is comparatively higher with η^2 equal to 15% for both groups of data. However, radius values do not impact directly on the choice of strategy. A possible explanation for this might be that drivers correct their trajectories while negotiating horizontal curves by shifting towards the centre of the road for leftward curves and on rightward curves they move towards the roadside (Bella, 2013). This lateral movement significantly effects the magnitude of the compensatory strategy (ΔASD). The magnitude

of variation may vary with curve direction. Calvi (2015) concluded that rightward curves show a higher variation in the lateral movement of vehicles compared to leftward curves.

To understand the effect(s) of direction and obstruction distance on driver behaviour, the results were plotted with respect to sight obstruction distance along rightward and leftward curves for both visibility profiles, as shown in Figure 11a. The different driver responses along the curves can be seen in the higher values for rightward curves in contrast to those for leftward curves. This means that under unsafe and partially safe visibility conditions, drivers increase the sight distance by making positive lateral movements to increase the margin of safety relative to the perceived risk. The same trend may be observed in Figure 11b, which illustrates the effects of curve direction and radius on the compensatory strategy.

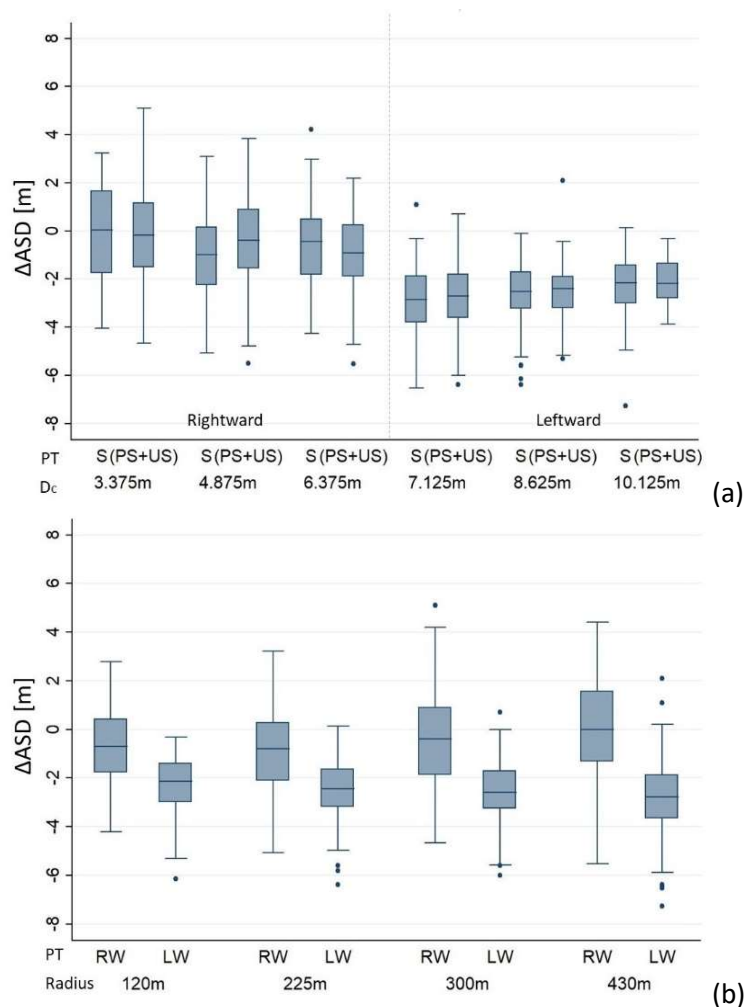

Figure 11. Risk compensation as per a lateral shift of the vehicle in the lane: (a) $\Delta ASD_{i,j}$ data distribution on the basis of visibility conditions (safe, S; partially safe, PS; unsafe, US) and per different sight obstruction distances (D_c); (b) $\Delta ASD_{i,j}$ data distribution on the basis of curve direction (rightward, RW; leftward, LW) and radius.

These results concur with those obtained by Zakowska (2010). In the case of rightward curves, most drivers tend to drive close to the centre of the lane, whereas the observed values for leftward curves remain negative for all curve radii (almost all drivers tend to move toward the centre of curvature, i.e. towards the sight obstruction). One possible reason for these negative values (no compensatory action) might be the existence of higher sight distance values in the case of leftward curves with respect to rightward ones, which in turn leads to a perception of greater safety in comparison with the rightward curves driven previously.

4. CONCLUSIONS

The present study was designed to determine the effect of sight limitations (caused by obstructions along horizontal curves) on the compensatory strategies adopted by drivers. With sight limitations, driver behaviour is conditioned by the inability to see any potential obstructions around the curves ahead. The experiment at the driving simulator recreated this scenario, and two compensatory strategies corresponding to a reduction in vehicle speed aimed at reducing the stopping distance (SSD), and a lateral shift to increase available sight distance (ASD) were observed and investigated. Two road tracks were designed with a combination of spiralled horizontal curves connected with straight tangents designed to meet the Italian Policy on road geometrics (MIT, 2001). A total of 1,246 case studies were generated by the forty-one participants who negotiated a series of curves with four different radii lengths (120, 225, 300, and 430 m) and with continuous 1.5 m high walls located at different offsets from the pavement edge.

The results of this investigation indicate that certain geometric factors characterizing curves have a significant effect on the compensatory strategies used. ANOVA showed that the radius was the geometric factor which had the greatest effect on the speed reduction strategy. This also explains why drivers are concerned by vehicle stability on more demanding, sharper curves ($r = 120$ m), while on wider curves most drivers increase speed because of higher perceived available sight distance values. Moreover, it was also found that the curve direction plays a significant role in the lateral shift compensatory strategy. The variation in ASD values observed on rightward curves was greater than on leftward curves, which means that some drivers increase the ASD with a lateral shift of the vehicle along rightward curves; some do the same on leftward ones but to a lesser degree.

Furthermore, the visibility condition profile type (safe, partially safe, and unsafe) plays a role in the adoption of certain compensatory strategies. It was observed that drivers under partially safe and unsafe visibility conditions were more prone to the use of compensatory strategies in comparison to those drivers travelling under safe conditions. The percentage of cases in which drivers opted for the speed reduction strategy was 40.4% with this figure increasing to 47% for partial safe conditions and

to 75.4% for unsafe visibility conditions. With respect to the lateral shift compensatory strategy, the percentage increments were 15.1% and 31.9% for safe and unsafe visibility conditions respectively.

As regards choice of compensatory strategy, a clear majority of drivers preferred a reduction in speed. Results demonstrate that with this strategy, drivers benefitted from a greater reduction in SSD with respect to that obtained with a lateral movement of the vehicle (included in the interval of -7.3 and + 5.1 m). Moreover, this study confirmed that most drivers managed to use the speed reduction compensatory strategy while negotiating sharp curves ($r = 120$ m) under both safe and unsafe (PS+US) visibility conditions. The pattern for the percentage distribution of sight conditions and compensation strategies employed for the sharpest curve considered here ($r=120$ m) was completely different to that for shallower curves ($r \geq 225$ m).

Furthermore, the results revealed no apparent relationship between driver speed profiles (slower, average, and faster) and the compensatory categories. The results also illustrate how inexperienced drivers (in comparison with more experienced ones) assumed a safer approach to curves with sight restrictions. It would seem that more experienced drivers have greater confidence in their ability to operate under risky sight conditions. The driver profile categories could be reinforced in future studies by the addition of other factors (age, gender, driving experience, etc.) which were not explored in detail here due to the limited number of drivers involved.

5. RECOMMENDATIONS

The results of this investigation also confirm that design prescriptions for the evaluation of the available sight distance (AASHTO, 2011; MIT, 2001) are appropriate, realistic and reflect average driving conditions. In particular, road design policies assume that the driver moves along the centreline; in these experiments, driver positions (i.e., the lane gap, LG) were found to be across the lane centreline, leading to differences between actual (ASD_a) and conventional (ASD_c) available sight distance values of only 3.9 – 5.7% according to the combination of investigated geometric variables.

These findings have significant implications for an understanding of how operating speed and vehicle lateral positioning along curves, and approaching and leaving sections increase the margin of safety. Providing drivers with continuous speed limit information would improve safety on the roads (Charlton et al., 2018), together with specific road markings which could be of assistance to drivers when adopting appropriate lateral positions along curves (Awan et al., 2019; Charlton, 2007).

This study contributes to a better understanding of the behavioural adaptation of drivers to geometric design factors, which is of fundamental importance in the comprehension of interactions between the driver and the road environment with implications for (i) new road design guidelines and

the re-design of existing ones, (ii) speed limit management for existing roads, and (iii) driver road safety campaigns.

Road designers should keep in mind that even if the conventional sight prescription ($ASD_c \geq SSD_c$) is satisfied (AASHTO, 2011; MIT, 2001), actual driving conditions may result in ASD_a being lower than SSD_a due to unfavourable speeds and/or lateral position in the lane. Consequently, geometric road design settings must produce ASD_c values sufficiently greater than SSD_c ones to ensure safe conditions for those drivers who slightly exceed the speed limits and/or drive closer than expected to the sight obstruction. However, the designer should not adopt excessively high ASD_c values, since they induce higher speeds which in turn may compromise overall safety conditions (Bassani et al., 2019).

Furthermore, road analysts should regard the available sight distance as a factor when establishing speed limits along horizontal curves (Charlton and de Pont, 2007; Campbell et al. 2012). The results of this investigation demonstrate that a significant number of drivers operating under unsatisfactory sight conditions (i.e., partially safe and unsafe) do not react to these conditions with a reduction in speed and/or a lateral movement in the lane. Hence, this segment of the driver population must be encouraged to alter their behavior vis-à-vis the presence of an adequate and consistent number of posted speed limit signs.

Educational road safety campaigns and programs are necessary to compensate for the hazardous behaviour of a significant proportion of drivers across all the different age categories. They should inform drivers on possible compensatory manoeuvres in the event of sight limitations, and promote a policy of speed reduction rather than lateral movement as a means to improve the available sight distance. It is worth highlighting that excessive lateral movements along right-ward curves (aimed at improving ASD) increase the possibility of a collision with oncoming traffic on the opposite lane. This investigation demonstrates that experienced drivers are more confident (perhaps excessively so) in negotiating curves than less experienced drivers. One out of two do not adopt any compensatory strategy, a greater proportion than in the two younger age classes.

The findings of this study illustrate the usefulness of driving simulation studies when seeking to explore the complex interactions between the driver, vehicle and the road environment with significant implications for road safety and road design practices. One important limitation of any simulation study, however, is related to the level of risk perceived by drivers, which is lower compared to real driving conditions. This is understandable since virtual crashes do not have the same impact on drivers as real crashes and do not cause any damage. Nevertheless, the results of this investigation can be used to interpret real driving conditions on foot of the relative validation reached by the used simulator (Bassani et al. 2018; Catani and Bassani, 2019). Finally, other limitations concern the

restricted number of road environment and geometry parameters used in this study which, of course, can be expanded in future investigations.

ACKNOWLEDGEMENT

The authors acknowledge Mr. Andrea Salussolia and Mr. Davide Salinardi for their valuable help in organizing the experiments, and the forty-one voluntary participants that took part in this investigation. Prof. Leandro Luigi Di Stasi (Ramón y Cajal Fellow at the Neuroergonomics and Operator Performance Laboratory of the Mind, Brain, and Behavior Research Center - University of Granada) is greatly acknowledged for the useful discussion. We are also grateful for the insightful comments offered by the two anonymous peer reviewers.

REFERENCES

- AASHTO (2011). *A policy on geometric design of highways and streets*, 6th edition. American Association of State Highway, and Transportation Officials, Washington, D.C.
- ACI-ISTAT (2018). *Road Accidents Year 2017*. Automobil Clud d'Italia. Report. Available on line: http://www.aci.it/fileadmin/documenti/studi_e_ricerche/dati_statistiche/incidenti/Road_accidents_in_Italy_-_2017.pdf
- Awan, H. H., Pirdavani, A., Houben, A., Westhof, S., Adnan, M., & Brijs, T. (2019). Impact of perceptual countermeasures on driving behavior at curves using driving simulator. *Traffic injury prevention*, 20(1), 1-7. <https://doi.org/10.1080/15389588.2018.1532568>.
- Bassani, M., Catani, L., Ignazzi, A. A., & Piras, M. (2018, September). Validation of a Fixed-Base Driving Simulator to Assess Behavioural Effects of Road Geometrics. In *Proceedings of the DSC 2018 EUROPE^{VR} Driving Simulation Conference & Exhibition* (pp. 101-108). Antibes, France.
- Bassani, M., Catani, L., Salussolia, A., & Yang, C.Y.D. (2019). A driving simulation study to examine the impact of available sight distance on driver behavior along rural highways. *Accident Analysis and Prevention*, 131, 200–212. <https://doi.org/10.1016/j.aap.2019.07.003>.
- Bella, F. (2013). Driver perception of roadside configurations on two-lane rural roads: Effects on speed and lateral placement. *Accident Analysis and Prevention*, 50, 251-262.
- Bella, F. (2014). Driver perception hypothesis: driving simulator study. *Transportation Research Part F: Traffic Psychology and Behaviour*, 24, 183-196.
- Ben-Bassat, T., & Shinar, D. (2011). Effect of shoulder width, guardrail and roadway geometry on driver perception and behavior. *Accident Analysis and Prevention*, 43(6), 2142-2152.
- Calvi, A. (2015). A study on driving performance along horizontal curves of rural roads. *Journal of Transportation Safety & Security*, 7(3), 243-267.
- Campbell, J. L., Richard, C. M., Graham, J. (2012). *Human factors guidelines for road systems*. NCHRP Report 600, Transportation Research Board, Washington, DC.
- Catani, L. & Bassani, M. (2019, January). Anticipatory Distance, Curvature, and Curvature Change Rate in Compound Curve Negotiation: A Comparison between Real and Simulated Driving. In *Proceedings of the 98th TRB Annual Meeting*. Washington, D.C.
- Catani, L. (2019). *A Simulation Based Study on Driver Behavior when Negotiating Curves with Sight Limitations*. Doctoral dissertation, Politecnico di Torino, Turin, Italy.

- Charlton, S. G. (2007). The role of attention in horizontal curves: A comparison of advance warning, delineation, and road marking treatments. *Accident Analysis and Prevention*, 39(5), 873-885.
- Charlton, S. G., and de Pont, J. J. (2007). *Curve Speed Management*. Research Report 323. Land Transport New Zealand, Wellington, NZ.
- Charlton, S. G., Starkey, N. J., Perrone, J. A., & Isler, R. B. (2014). What's the risk? A comparison of actual and perceived driving risk. *Transportation Research Part F: Traffic Psychology and Behaviour*, 25, 50-64.
- Charlton, S. G., Starkey, N. J., & Malhotra, N. (2018). Using road markings as a continuous cue for speed choice. *Accident Analysis & Prevention*, 117, 288-297.
- Cobb, S. V., Nichols, S., Ramsey, A., & Wilson, J. R. (1999). Virtual reality-induced symptoms and effects (VRISE). *Presence: Teleoperators & Virtual Environments*, 8(2), 169-186.
- Comte, S. L., & Jamson, A. H. (2000). Traditional and innovative speed-reducing measures for curves: an investigation of driver behaviour using a driving simulator. *Safety Science*, 36(3), 137-150.
- Coutton-Jean, C., Mestre, D. R., Goulon, C., & Bootsma, R. J. (2009). The role of edge lines in curve driving. *Transportation Research Part F: Traffic Psychology and Behaviour*, 12(6), 483-493.
- Green, M. (2000). "How long does it take to stop?" Methodological analysis of driver perception-brake times. *Transportation human factors*, 2(3), 195-216.
- Kanellaidis, G. (1995). Factors affecting drivers' choice of speed on roadway curves. *Journal of Safety Research*, 26(1), 49-56.
- Layton, R., & Dixon, K. (2012). Stopping sight distance. *Kiewit Center for Infrastructure and Transportation*, Oregon Department of Transportation.
- Lerner, N. D. (1993, October). Brake perception-reaction times of older and younger drivers. In *Proceedings of the human factors and ergonomics society annual meeting* (Vol. 37, No. 2, pp. 206-210). Sage CA: Los Angeles, CA: SAGE Publications.
- Lewis-Evans, B., & Charlton, S. G. (2006). Explicit and implicit processes in behavioural adaptation to road width. *Accident Analysis and Prevention*, 38(3), 610-617.
- McDonald, N. (2004, August). Look and learn: Capitalising on individual responsibility in speed management. In *Australian Institute of Traffic Planning and Management (AITPM) National Conference*, Adelaide, South Australia, Australia.
- Meiring, G. A., & Myburgh, H. C. (2015). A Review of Intelligent Driving Style Analysis Systems and Related Artificial Intelligence Algorithms. *Sensors (Basel, Switzerland)*, 15(12), 30653–30682.
- MIT (2001). *Norme funzionali e geometriche per la costruzione delle strade* (in Italian). Ministero delle Infrastrutture e dei Trasporti, D.M. no. 6792 of November 5th.
- MIT (2016). *Conto Nazionale delle Infrastrutture e dei Trasporti: Anni 2014-2015* (in Italian). Ministero delle Infrastrutture e dei Trasporti, Istituto Poligrafico e Zecca dello Stato S.p.A. Roma, Italy.
- Moreno, A. T., Garcia, A., Camacho-Torregrosa, F. J., & Llorca, C. (2013). Influence of highway three-dimensional coordination on drivers' perception of horizontal curvature and available sight distance. *IET Intelligent Transport Systems*, 7(2), 244-250.
- National Highway Traffic Safety Administration (2008). *Fatality analysis reporting system*. Retrieved from <http://www-nrd.nhtsa.dot.gov/Pubs/811171.pdf>
- OECD (1990). *Behavioural adaptations to changes in the road transport system*. Organization for Economic Co-operation and Development, Paris, France.
- Philip, P., Taillard, J., Klein, E., Sagaspe, P., Charles, A., Davies, W. L., Guilleminault, C., & Bioulac, B. (2003). Effect of fatigue on performance measured by a driving simulator in automobile drivers. *Journal of Psychosomatic Research*, 55(3), 197-200.
- Reymond, G., Kemeny, A., Droulez, J., & Berthoz, A. (2001). Role of lateral acceleration in curve driving: Driver model and experiments on a real vehicle and a driving simulator. *Human factors*, 43(3), 483-495.

- Rizzo, M., McGehee, D. V., Dawson, J. D., & Anderson, S. N. (2001). Simulated car crashes at intersections in drivers with Alzheimer disease. *Alzheimer Disease & Associated Disorders*, 15(1), 10-20.
- Weller, G. (2010). *The psychology of driving on rural roads*. Springer Fachmedien.
- Weller, G., Schlag, B., Friedel, T., & Rammin, C. (2008). Behaviourally relevant road categorisation: A step towards self-explaining rural roads. *Accident Analysis and Prevention*, 40(4), 1581-1588.
- Wilde, G. J. (1982). The theory of risk homeostasis: implications for safety and health. *Risk analysis*, 2(4), 209-225.
- Wilde, G. J. (1994). *Target risk: Dealing with the danger of death, disease and damage in everyday decisions*. Castor & Columba.
- Wilde, G. J. (2001). *Target risk 2: a new psychology of safety and health: what works? what doesn't? and why-*. Pde Pubns.
- Williams, J. R. (2008). The declaration of Helsinki and public health. *Bulletin of the World Health Organization*, 86, 650-652.
- Zakowska, L. (2010). Operational and safety effects of transition curves in highway design-A driving simulator study. In *4th International Symposium on Highway Geometric Design* Polytechnic University of Valencia Transportation Research Board.

APPENDIX

Actual and conventional available sight distance ($ASD_{c,d}$) estimation

The simulator data were collected for each driver along the investigated curves, as well as along the approaching and leaving sections at reference points and stations (Figure 3). Due to the large amount of data, the manual calculation of actual ASD values for each driver along each curve required a lot of effort. For this reason, the estimation of the actual available sight distance (ASD_a)_{*ij*} was achieved with the calibration of models providing the ASD from five fixed points on the driving lane at each reference point (Figure 3). Figure A1 exhibits the different lines of sight from the five positions (*p*) considered at station SC (Spiral to Curve point). These points were equally spaced at $l_w/4$ apart on both sides with respect to the lane centreline (with l_w representing the lane width). The same procedure was adopted for the other stations (TS – 50 m, TS – 20 m, TS, CS_{en}).

The fixed reference positions were identified as follows: *p* = centre of the driving lane (lane centreline); *p*₊₁ = middle point between lane and road centreline; *p*₊₂ = road centreline; *p*₋₁ = middle point between lane centreline and rightward lane edge; *p*₋₂ = rightward lane edge.

A total of 24 cases were analysed, resulting from the combination of two curve directions, four radius (*r*) values, and three sight obstruction distances from the road edge (*d*). For each case, 10 models were calibrated based on the reference stations (five before the circular arc – observer position – and five after the circular arc – target position; Figure 3). Thus, in this analysis 240 (24 × 10) equation models were used to estimate the (ASD_a)_{*ij,k*} for *i*-th curve, travelled by the *j*-th driver at *k*-th station.

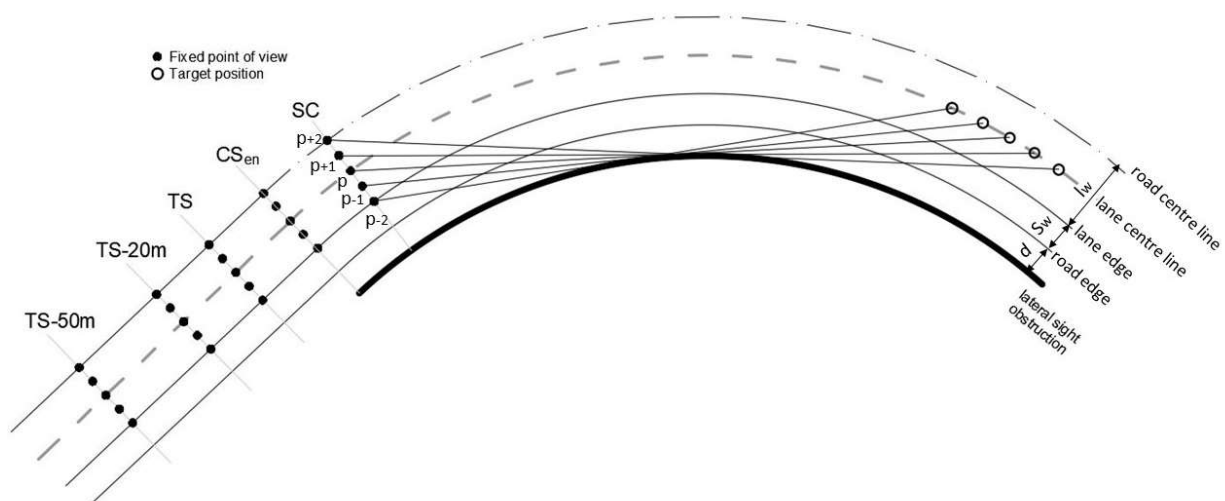

Figure A1. Example of scheme for available sight distance computation from lines of sight of fixed points on the driving lane at the SC station along a rightward curve (not in scale).

The results of the model calibration for a rightward curve, with a radius of 300 m, and a sight obstruction distance (d) of 1.5 m from the shoulder are reported below. The calculated sight distances from twenty-five fixed points at the curve approaching stations are shown in Figure A2. A second order polynomial interpolation between the ASD values computed at the same k -th station was found to be appropriate:

$$(ASD_a)_j = a(LG^2)_j + b(LG)_j + c \quad (A1)$$

where $(ASD_a)_j$ is the actual available sight distance (in m) for j -th driver; and $(LG)_j$ is the lane gap (in m) from driving simulator data as the lateral displacement of j -th driver point of view from the lane centreline. Coefficients for the example of Figure A2 are listed in Table A1.

Table A1. Calculated coefficients at k -th station for rightward curve, with radius of 300 m, and a distance to the sight obstruction (d) of 1.5 m from the shoulder for the reference points (Figure 3).

Reference points	Coefficients		
	a	b	c
TS – 50 m	-0.052	3.06	151.33
TS – 20 m	-0.006	4.13	128.92
TS	-0.079	4.86	117.62
CS _{en}	-0.179	5.56	109.34
SC	-0.204	5.69	107.90

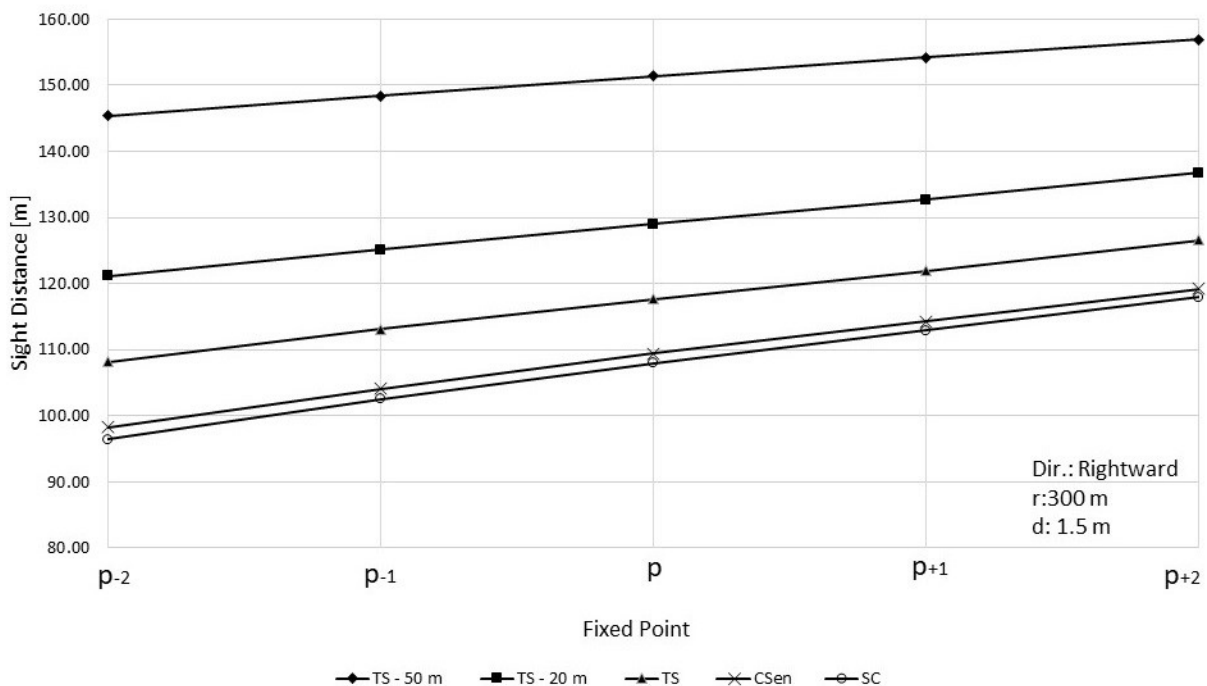

Figure A2. Example of available sight distances computed at TS-50 m, TS – 20 m, TS, CS_{en} and SC. (Notes: p = centre of driving lane; p_{-2} = inner end of the lane; p_{+2} = exterior end of the lane; p_{+1} and p_{-1} = centre points between lane axis and edges).