

A driving simulation study to examine the impact of available sight distance on driver behavior along rural highways

Original

A driving simulation study to examine the impact of available sight distance on driver behavior along rural highways / Bassani, M., Catani, L., Salussolia, A., Yang, C.Y.D.. - In: ACCIDENT ANALYSIS AND PREVENTION. - ISSN 0001-4575. - 131:(2019), pp. 200-212. [10.1016/j.aap.2019.07.003]

Availability:

This version is available at: 11583/2742181 since: 2019-07-16T10:30:35Z

Publisher:

Elsevier Ltd

Published

DOI:10.1016/j.aap.2019.07.003

Terms of use:

This article is made available under terms and conditions as specified in the corresponding bibliographic description in the repository

Publisher copyright

(Article begins on next page)

A DRIVING SIMULATION STUDY TO EXAMINE THE IMPACT OF AVAILABLE SIGHT DISTANCE ON DRIVER BEHAVIOR ALONG RURAL HIGHWAYS

Bassani^{a,*}, M., Catani^a, L., Salussolia^a, A., Yang^b, C. Y. D.

^a Department of Environment, Land and Infrastructures Engineering, Politecnico di Torino, Torino, Italy

^b AAA Foundation for Traffic Safety, Washington, D.C.

* = corresponding author

Marco Bassani: +39 011 564 5635, e-mail: marco.bassani@polito.it

Lorenzo Catani: +39 011 564 5623, e-mail: lorenzo.catani@polito.it

Andrea Salussolia: e-mail: salussoliaandrea@yahoo.it

C. Y. David Yang: +1 202 639 3400, e-mail: dyang@aaafoundation.org

ABSTRACT

The available sight distance (ASD) is the maximum length of the roadway ahead visible to the driver. It is a fundamental factor in road geometry principles and is used by road designers to ensure safe driving conditions. However, designers do not know how a specific ASD may affect the longitudinal and transversal behavior of drivers engaged in negotiating curves.

This paper focuses on analyzing driver longitudinal behavior along rural highways curves with limited visibility. A number of virtual sight condition scenarios were recreated and tested in the driving simulator. Three tracks were designed with various combinations of radii and sight obstructions (a continuous wall) along the roadside located at various offsets from the lane centerline, combinations which resulted with a minimum ASD of 56.6 m. Roadside factors capable of influencing the risk perception of drivers (e.g., traffic barriers, posted speed limit signs, vegetation) were all excluded from the simulations.

Results indicate that speed and trajectory dispersion from the lane centerline depend linearly on ASD in the investigated range of curve radii (from 120 to 430 m). In general, when ASD increases, so does speed and the trajectories tend to be less dispersed around the lane centerline. As a result, in safety terms, any variation in ASD will have the polar opposite effect on safety related parameters. Furthermore, different curves with similar ASD values resulted in different speed and lateral control behaviors. Analysis from ANOVA support the same findings; in addition, radius, curve direction, and distance from trajectory to sight obstruction have been identified as significant independent parameters. Road designers should adjust the ASD and these parameters when seeking to encourage drivers to adopt appropriate behaviors. To optimize safe driving conditions, ASD should be designed so that it is slightly greater than the required sight distance, since excessive ASD values may encourage drivers to drive at inappropriate speeds.

Keywords: available sight distance, longitudinal driver behavior, transversal driver behavior, driving simulation, vehicle trajectories.

40 1. INTRODUCTION

41 Drivers need to be able to see a sufficient length of the roadway ahead in order to (i) avoid hitting a stationary
42 object along the path, (ii) overtake slower vehicles where permitted, and (iii) make appropriate driving
43 decisions at complex locations such as intersections or when coming across traffic diversion signs. To meet
44 these requirements, designers are obliged to adopt appropriate values for the geometric variables that
45 characterize the horizontal and vertical alignments, as well as the cross-section of roads.

46 In order to translate these needs into standard practices and design decisions, road geometric policies
47 (AASHTO, 2011; MIT, 2001) establish that the length of the road ahead visible to the driver, which is the
48 available sight distance (ASD), must be greater than or at least equal to the required sight distances (RSD) for
49 stopping (SSD), passing (PSD), and taking decisions (DSD); their magnitude depends on the adopted design
50 speed. In accordance with policies, $ASD \geq RSD$ is a required condition for safe driving operations. Along
51 horizontal curves, the ASD may be limited by the presence of sight obstructions such as vegetation,
52 escarpments, traffic barriers, and buildings which encroach onto the carriageway.

53 Results from previous studies highlighted the correlation between crash frequency and ASD for specific
54 road sections (Sparks, 1968; Urbanik et al., 1989; Steinauer et al., 2002). From an investigation into more
55 than 100 km of roads on which 500 crash events occurred during the period of investigation, Castro and De
56 Santos-Berbel (2015) found that excessive speed combined with insufficient ASD values may have caused
57 approximately 4% of the crashes recorded. Hence, driving safety is affected by insufficient ASD values,
58 although the limited number of investigations conducted would suggest a need for more researches to be
59 carried out to clarify the relationship between sight conditions and safety (i.e., crash frequency, crash
60 severity.

61 Road engineers design the horizontal and vertical alignment, as well as the cross section to obtain an
62 ASD which is always greater than the RSD. Alternatively, when permitted by standards, designers impose an
63 appropriate speed limit to encourage drivers to maintain the RSD below the ASD. These design decisions are
64 based on set standards to deter any unintended consequences.

65 According to the risk compensation theory (Summala, 1996), it is to be expected that a greater ASD
66 leads to a lower perception of risk, and this may induce drivers into taking higher risks by speeding.
67 Conversely, a shorter ASD may encourage people to drive more prudently and within the posted speed limit.
68 In support of such a hypothesis, Weller et al. (2008) observed that ASD affects driver speed behavior and
69 may make a contribution to the categorization of roads. However, these hypotheses need to be confirmed
70 through adequate investigation, and a quantification of any relationship is necessary for professionals and
71 experts involved in the development and improvement of road design standards.

72 Currently, designers do not question whether decisions that imply $ASD > RSD$ are better (safer) or
73 worse (more dangerous) than cases where the ASD is significantly greater than the RSD. Furthermore, there
74 is a lack of knowledge among practitioners as to how a certain ASD may contextually affect the longitudinal
75 and transversal behavior of drivers engaged in negotiating curves.

76 In order to address the research questions, the authors carried out experiments using a driving
77 simulator in which road scenarios characterized by different ASD values were established on a two-lane
78 highway designed with horizontal radius curves ranging from 120 to 430 m. On some curves, a sight
79 obstruction in the form of a continuous wall was placed at 0 to 3 m (*d*) from the road edge. The effects of
80 other roadside factors (e.g., safety barriers, vegetation, roadside hazards) that may influence driver risk
81 perception and, consequently, his/her longitudinal and transversal behavior were not included in the
82 simulated road scenarios.

83

84 **2. RELATED WORK**

85 Past studies identified a linear relationship between operating speed and curvature of the roadway
86 (Transportation Research Circular, 2011), albeit there remain some uncertainties regarding the
87 predominance of curvature with respect to sight distance when it comes to the choice of preferred speed.
88 Furthermore, a combination of the information deriving from road alignment curvature and information
89 deriving from roadside features (i.e., horizontal markings, traffic-calming measures, road pavement
90 conditions, lane width, lateral clearance, etc.), compels drivers to adopt the most appropriate longitudinal
91 and transversal behavior (Martens et al., 1997; Jamson et al., 2010).

92 From data collected in field observations along four-lane roadways in Indiana (US), Figueroa Medina
93 and Tarko (2004) investigated operating speeds and related models including random effects. Speeds along
94 curves were found to be linearly dependent on both sight distance and curvature: an increase in sight
95 distance leads to an increase in the mean speed, while an increase in the degree of curvature leads to a
96 decrease in the mean speed and an increase in the level of speed dispersion around the mean. However, in
97 the proposed models, other road and environmental factors were also found to be significant. Similarly,
98 Bassani et al. (2014) found that independent variables principally related to cross-sectional characteristics
99 rather than the longitudinal ones (i.e., alignment element) were predominantly significant in the case of
100 urban roads.

101 In a driving simulation study, Ben-Bassat and Shinar (2011) investigated driver behavior on thirty
102 different road configurations reproduced by varying road element (straights/curves) characteristics, curve
103 radius (sharp/shallow), shoulder width (0.5, 1.2, and 3.0 m), and guardrails (present, absent). They found that
104 the shoulder width along straight sections and rightward curves with guardrails was the most influential
105 factor, since it contributes to an increase in the sense of security while driving. On leftward curves, the effects
106 of lateral elements become non-influential.

107 Bella (2013) added to the previous variables the presence/absence of shoulders and barriers with trees
108 along a two-lane rural road section reproduced at a driving simulator. Results revealed that driver behavior
109 was only affected by the cross-sections and geometric elements and not by roadside configuration (the
110 presence of trees along the road was not found to be influential even in the absence of barriers). Contrasting
111 results in the work of Ben-Bassat and Shinar (2011) could be a product of the cross-sectional characteristics

112 (four-lane divided carriageways in the case of Ben-Bassat and Shinar vs. two-lane rural roads in the case of
113 Bella).

114 The effect of vegetation along the roadside was also investigated by Calvi (2015a). Four rural road
115 scenarios with trees spaced apart and at different distances from the road edge were the focus of an
116 experiment using, once again, a driving simulator. When compared to the base condition (i.e., no trees along
117 the roadside), drivers reduced their speeds and moved towards the road centerline when trees were close
118 to the shoulder. When trees were far from the roadway, drivers adopted higher speeds and reduced lateral
119 displacements with respect to the lane axis. Along sharp curves, this behavior was more evident.

120 Bella (2013) and Calvi (2015a) both supported their inferences by concluding that drivers manage the
121 vehicle trajectory by referring to the visual guidance mechanism provided by road elements in their field of
122 vision. Bella (2013) considered the positive effect of continuous roadside elements such as road markings
123 and/or guardrails, whereas Calvi (2015a) ascribed the guidance effect to trees. Conversely, van der Horst and
124 de Ridder (2007) did not find any guidance effect due to the type of guardrail, although driving behavior
125 changed as a function of its distance from the lane (presence/absence of emergency lane). Although the
126 authors did not seek to explain these results, safety barrier type (flexible or rigid) was regarded as the
127 determining factor.

128 Another investigation by Calvi (2015b) focused on driving performance for different cross-sections and
129 posted speed limits. Three curve radii (200, 500, and 1000 m), two visibility conditions
130 (restricted/unrestricted), and the presence or absence of transition curves were considered. In particular,
131 visibility conditions were referenced to the relationship between the ASD and the SSD: they were indicated
132 as “unrestricted” when $ASD \geq SSD$, and “restricted” when $ASD < SSD$, with SSD computed according to the
133 Italian Road Design policy (MIT, 2001). Speeds were higher in wider lanes and divided carriageways, and
134 average speed increased when the curve radius was larger. The experiment confirmed that along sharp
135 curves speed was not influenced by the curve direction (right/left); in these driving conditions, the accuracy
136 of the travelled trajectory was greater than that obtained with higher radii of curvature. It should be noted
137 that the highest speeds recorded in this study were for road configurations with guardrails, thus confirming
138 that continuous elements have a guidance effect on drivers. Moreover, speeds adopted on sections with
139 restricted visibility failed to satisfy safe driving conditions since the SSD was not guaranteed.

140 None of the previous researches evaluated the effects that ASD can have on speeds and related vehicle
141 trajectories when drivers are negotiating curves with known visibility conditions. Consequently, the primary
142 objective of this study is to determine whether this fundamental design parameter, used to assess standard
143 safety conditions, influences drivers when they are deciding the most appropriate longitudinal and
144 transversal behavior along curves, and if the degree of adjustment in their behavior correlates with the
145 magnitude of the variable. In the road design scenarios, no speed limit signs (vertical ones), safety barriers,
146 and vegetation were employed. According to the above literature, they were found to influence driver speed
147 and position choice, so they were excluded as a factor in the design of this experiment.

148 **3. METHODOLOGY**

149 This research used a fixed-base driving simulator to examine road scenarios in which design variables of the
150 horizontal alignment and cross section were manipulated to obtain a variety of ASD values. As already
151 mentioned, no simulated vegetation, trees, speed limit signs, and/or traffic barriers were placed along the
152 roadside in order to provide the subjects involved in the experiment with a level of risk perception which is
153 solely attributable to the limited sight conditions. Accordingly, a continuous wall was placed at different
154 offsets from the road edge to manage ASD values.

155 Figure 1 depicts the general method used in this experiment to estimate the ASD from the horizontal
156 radius and the position of sight obstruction(s). According to road design guidelines (AASHTO, 2011;
157 MIT, 2001), the driver line of sight is, by convention, positioned in the center of the travelled lane, and the
158 ASD is calculated as the distance between the driver and the farthest point visible along the future vehicle
159 trajectory.

160 In Figure 1, the subscript “1” is used to identify the vehicle moving from left to right, while the subscript
161 “2” denotes the one travelling from right to left. Following a circular curved trajectory of radius r_i (with
162 $i = 1, 2$) with a sight obstruction placed at a constant distance D_i from the same trajectory, drivers who travel
163 along the rightward ($i = 1$) and the leftward ($i = 2$) curve benefit from an ASD_i equal to:

164
$$ASD_i = 2r_i \cdot \arccos\left(1 - \frac{D_i}{r_i}\right) \quad (1)$$

165 In Figure 1, the two D_i offsets (D_1 for the vehicle turning rightward, and D_2 for the vehicles turning
166 leftward) are equal to:

167
$$D_1 = d + s_w + \frac{1}{2} \cdot l_w \quad (2)$$

168
$$D_2 = d + s_w + \frac{3}{2} \cdot l_w \quad (3)$$

169 where d is the distance of the sight obstruction from the road edge, s_w is the shoulder width, and l_w is the
170 lane width.

171 It should be noted that eq. 1 provides a conventional estimate of ASD under the simplified
172 hypothesis, supported by current road geometric guidelines, in which the driver moves along the lane axis.
173 In real driving situations, the actual driver position could be shifted laterally away from the lane axis, so the
174 effective ASD changes slightly during the experiment. However, in a preliminary analysis it was observed that
175 the variation in ASD from the driver point of view fell within a range of ± 7 m around the conventional ASD
176 values, assuming different driver positions in the lane, radius values in the range $120 \leq R \leq 430$ m, and
177 distance of the sight obstruction from the road edge values in the range $0 \leq d \leq 3$ m. Consequently, the
178 conventional ASD was considered as the dependent factor, and it was kept constant along the entire curve
179 length in order to reflect stationary conditions and allow the drivers adapt to sight conditions.

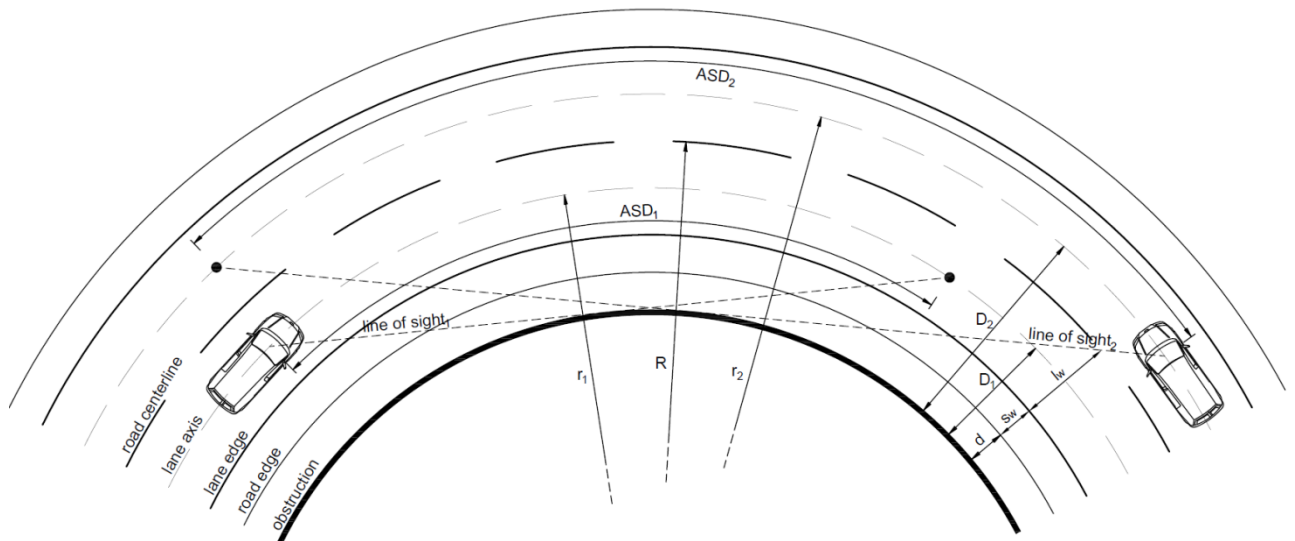

180 **Figure 1.** Conventional available sight distance (ASD) along a horizontal curve elaborated from road geometric policies
 181 (AASHTO, 2011; MIT, 2001). In the figure: R is the radius of the road axis; r_1 and r_2 are the radii of the right- and leftward
 182 turn trajectories respectively; D_1 and D_2 are the offsets of sight obstruction from the right- and leftward trajectories
 183 respectively; d is the distance of sight obstruction from the road edge; s_w is the shoulder width; ASD_1 and ASD_2 are the
 184 available sight distances from the right- and leftward trajectories respectively.
 185
 186

187 3.1 Apparatus

188 The fixed-base driving simulator of the Department of Environment, Land and Infrastructure Engineering at
 189 the Politecnico di Torino (Italy) was used for this multi-factorial experiment. The hardware consists of a
 190 complete cockpit with steering wheel, manual gears, pedals, and dashboard. Three 32-inch full HD screens
 191 (1920×1080 pixels each) provide a horizontal field of view of 130° . In combination with the video card, the
 192 three monitors update the images at a frequency higher than 50 Hz. The speedometer and the rev counter,
 193 as well as other in-vehicle displays, are visible on a small monitor attached to the back of the steering wheel
 194 and are always visible to drivers during experiments. The steering wheel is furnished with a force feedback
 195 sensor to simulate the rolling motion of wheels and shocks. Sound effects are reproduced through five
 196 speakers placed behind the screens and beneath the driver's seat, where there is a subwoofer.

197 The software used to design tracks, generate scenarios, and run experiments was *SCANeRTMstudio*.
 198 Data were collected with a frequency of 10 Hz and exported from the same software. The speed and lateral
 199 position in this driving simulation experiment were validated prior to data collection (Bassani et al., 2018;
 200 Catani and Bassani, 2019).

201 The same type of vehicle, a family car characterized by the performance levels of a typical vehicle
 202 commonly found in Italy (UNRAE, 2016), was used for all the experiments. The dynamic model corresponds
 203 to a passenger car powered by a 130 hp gas engine, with six manual gears and automatic clutch and with the
 204 brake pedal set to "race regulation". The car model uses a numerical method with a constant time step.

205

206 **3.2 Scenarios, experimental design and research variables**

207 For this study, two basic alignments of a standard two-lane rural road with lane width (l_w) equal to 3.75 m,
 208 and shoulder width (s_w) equal to 1.5 m were designed. Despite obtaining a reduction in the computational
 209 size of the model, the two roads included all combinations of the two main variables affecting ASD: (i) the
 210 radius of curvature (R), and (ii) the distance from the trajectory to the lateral sight obstruction (D).

211 Four curve radii ($R_1 = 120$ m, $R_2 = 225$ m, $R_3 = 300$ m, and $R_4 = 430$ m) were selected in the design speed
 212 variation range of 60-100 km/h as per Italian policy (MIT, 2001). For stability reasons, the cross slope along
 213 curves was set equal to 7% in accordance with the same policy; spirals were also adopted to enable the
 214 transition of cross slope from tangent to curve, and vice versa.

215 A continuous stone wall with a height of 1.5 m above that of the driver line of sight was employed as
 216 a lateral sight obstruction to generate specific ASD values. Walls were placed along the inner sides of curves
 217 and at different distances (d) from the road edge (see Figure 2). Three specific distances d were selected
 218 equal to 0, 1.5, and 3 m, resulting in six values of D as a function of the hand of the curve. Table 1 lists the
 219 ASD values computed from a combination of D and R and, also, of the driving direction according to eq. 1.
 220 Curves with deflection angles (ω) greater than 60° were adopted for two reasons: (i) to obtain a constant
 221 value for ASD along curves, thus providing stationary sight conditions for a sufficient time (and space) along
 222 curves, and (ii) to allow drivers to adjust and stabilize their behavior in terms of speed and lateral position in
 223 the lane.

224 Three tracks were selected to cover all potential combinations of design variables (Figure 2), and to
 225 consider the case of unlimited sight conditions ($d = \text{infinite}$) along curves. The first alignment was 12,888 m
 226 long, and was used to design the tracks A and A-mod; the differences between these tracks being the absence
 227 of sight limitations along certain curves along which drivers enjoyed unrestricted sight conditions. The second
 228 alignment was 14,444 m long, and was used to define track B. The lengths of the three tracks were designed
 229 to limit the duration of the experiment to below 20 minutes to minimize driver fatigue, sickness, and
 230 boredom (Philip et al., 2003). The choice of multiple tracks (and more scenarios) is consistent with techniques
 231 used to correct for the confounding effect (McGwin Jr., 2011).

232
 233 **Table 1.** Computed available sight distance (ASD) values according to eq. 1 for the combinations of curve radius (R),
 234 typology (right- and leftward), and distance of the lane centerline from the lateral sight obstruction (D). The table also
 235 includes the distance of the same sight obstruction from the road edge (d).

Radius	Rightward curves			Leftward curves		
	$D_1 = 3.375$ m $d_1 = 0$ m	$D_2 = 4.875$ m $d_2 = 1.5$ m	$D_3 = 6.375$ m $d_3 = 3$ m	$D_4 = 7.125$ m $d_1 = 0$ m	$D_5 = 8.625$ m $d_2 = 1.5$ m	$D_6 = 10.125$ m $d_3 = 3$ m
$R_1 = 120$ m	56.61	68.11	77.97	83.76	92.25	100.06
$R_2 = 225$ m	77.72	93.46	106.93	114.02	125.52	136.07
$R_3 = 300$ m	89.80	107.98	123.53	131.43	144.67	156.81
$R_4 = 430$ m	107.59	129.34	147.95	157.11	172.91	187.40

236

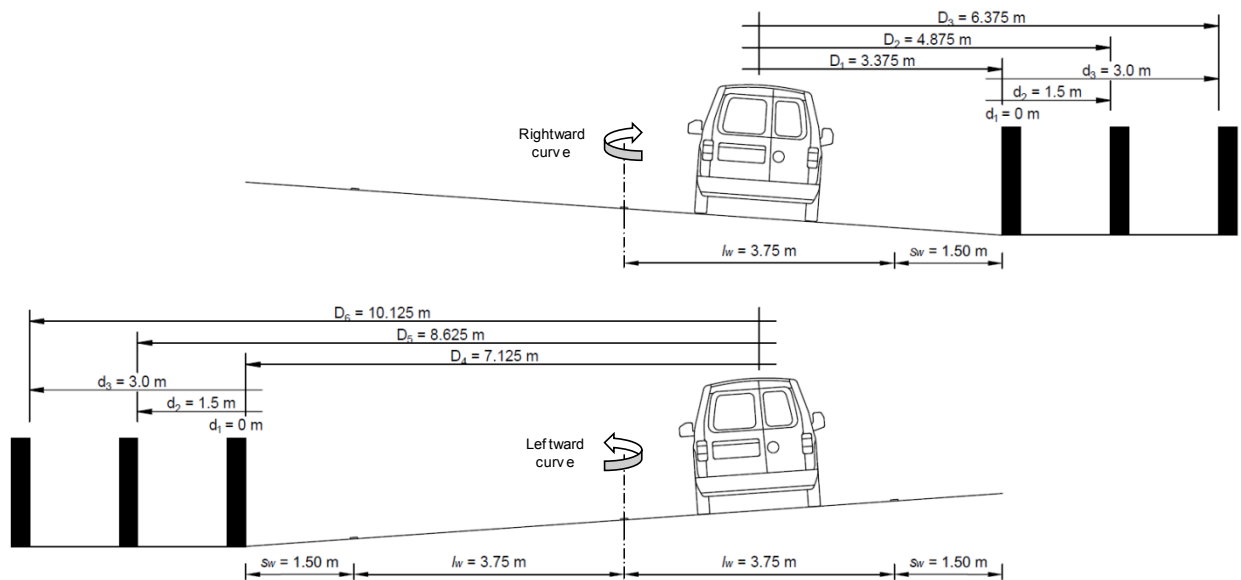

237
 238 **Figure 2.** Cross section of the road configuration on right-hand and left-hand curves, with the sight obstructions at
 239 different distances (D) from the lane centerline and the road edge (d).
 240

241 Each track included 18 circular curves generated from a combination of R and d (4×3), while other
 242 curves were included simply in order to complete the circuits. They were all placed between transition curves
 243 (clothoids) with a scale parameter set in a range from $R/3$ to R . The inclusion of spirals improves the optical
 244 perception of the road (Zakowska, 2010). The sequence of left- and rightward curves along both alignments
 245 was determined at random. Care was taken to avoid the use of the smallest radius before or after the largest
 246 one in order to be consistent with Italian and many other international standards (Brenac, 1996). This
 247 procedure is also necessary to avoid an excessive design and/or operating speed variation in two successive
 248 curves, and to meet driver expectations when traversing curves of different radii (Leisch and Leisch, 1977;
 249 Castro et al., 2011).

250 Figure 3 provides a curvature diagram of the three tracks, with the variables R and d , and the scale
 251 parameter A of the clothoids duly indicated. Tangents between curvilinear elements were designed to
 252 guarantee a length (L_t) such that $R > L_t$ for $L_t < 300$ m, and $R \geq 400$ m for $L_t \geq 300$ m (MIT, 2001). Therefore,
 253 their length was set in the 110-300 m range. As a result, both tracks consist of 35% of straight sections and
 254 65% of curvilinear elements. To limit the number of design variables, the terrain was kept flat for the two
 255 alignments.

256 Traffic volume consisted of some simulated vehicles moving in the opposite direction and, in a few
 257 cases, in the same direction as the test vehicle but sufficiently distant to rule out any impact on speed and
 258 sight distances. The simulated vehicles circulated inside the roadway through a secondary network and on
 259 set paths so there were always free-flow traffic conditions during the simulation. The three tracks in Figure 3
 260 were driven in both clockwise (CW) and anti-clockwise (CCW) directions, thus generating six different
 261 scenarios. Figure 4 provides some frames taken from the simulations that depict the effects of the sight
 262 obstruction offset at different d from the road edge for right- and leftward curves.

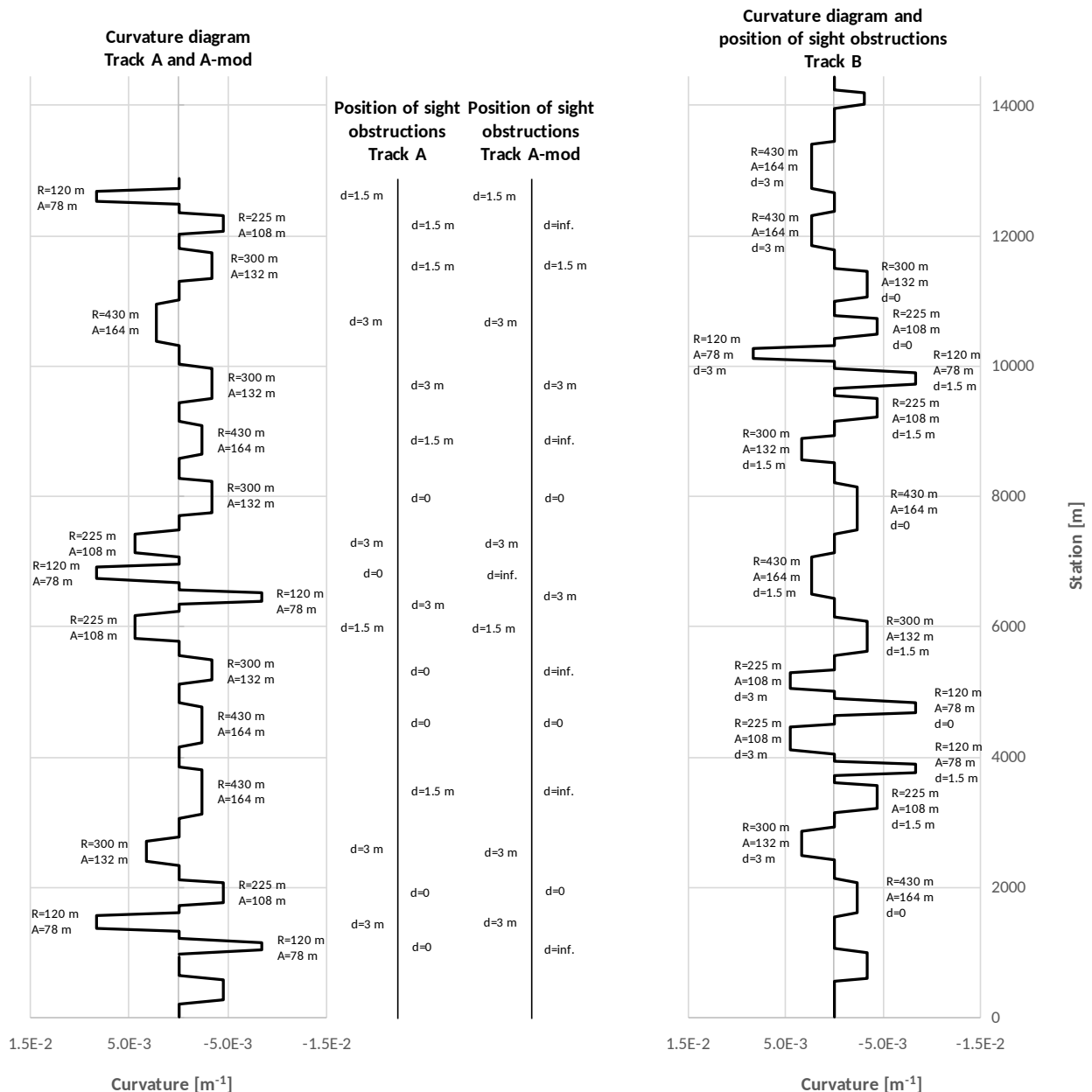

263
 264 **Figure 3.** Curvature diagram for the three tracks (A, A-mod, and B), with specification of curve radius R , scale parameter
 265 A of the clothoids, position of sight obstructions, and distance d of the lateral obstruction from the road edge.
 266

267 No vegetation, trees, vertical speed limit signs, and traffic barriers were placed along the roadside to
 268 guard the subjects involved in the experiment against any distractions and/or undesirable effects on their
 269 driving behavior. However, a few objects (e.g., container, parked vehicle, cones) were positioned on the
 270 shoulder, close to the end of a few curves to ensure drivers were being attentive. Some signs provided
 271 warnings before curves with $R = 120$ m only, while right of way signs were positioned at a few intersections
 272 to ensure once again that drivers were paying attention.
 273



274 **Figure 4.** Frames of right-hand and left-hand curves with sight obstructions at a distance d equal to 0, 1.5, 3 m, and
 275 without the lateral wall. Road delineators were included in accordance with the Italian Highway National Code
 276 (MIT, 1992).
 277

278 3.3 Participants

279 The simulation experiment involved the recruitment of 41 volunteers, 26 males (63%) and 15 females
 280 (37%), aged between 20 and 60 years (Table 2). Drivers were already familiar with the simulator since they
 281 had two training sessions (on different days) before starting with the experiments; none of them received
 282 any compensation (financial or otherwise) for their participation. None of the drivers experienced any
 283 sickness during the training phase or during the experiments. The choice of drivers and their age profile was
 284 an attempt to reflect Italian driver population characteristics (MIT, 2016). For the experimental task,
 285 participants were instructed to drive as they normally do, and to continue along the same lane for the entire
 286 experiment. As previously mentioned, other vehicles were included in the opposite direction and the few
 287 which were placed in the same driving direction were sufficiently distant from the simulated vehicles to
 288 create realistic conditions while at the same time avoiding the need for any overtaking maneuvers. The
 289 duration for the experiment was kept below 20 minutes to avoid any fatigue related effects on drivers.

290
 291
 292

293 **Table 2.** Characteristics of the driver sample set (Notes: M = mean, SD = standard deviation)

	No.	Age			Driving experience		No. accidents involved in	
		Min (-) (yrs)	M (yrs)	Max (yrs)	M (yrs)	SD (yrs)	M (-)	SD (-)
Males	26	20	36.3	60	17.3	11.5	1.1	1.5
Females	15	21	30.6	54	11.7	10.0	0.5	0.5
Total	41	20	34.2	60	15.2	11.2	0.9	1.2

294

295 **3.4 Experimental protocol, data collection and treatment**

296 The experimental protocol entailed the following steps:

- 297 (a) complete a pre-drive questionnaire;
- 298 (b) perform pre-drive cognitive tests (visual and auditory);
- 299 (c) drive on the first pre-selected track;
- 300 (d) rest for at least 10 min;
- 301 (e) drive on a second pre-selected track;
- 302 (f) perform the same cognitive tests in post-driving; and
- 303 (g) complete a post-drive questionnaire.

304

305 The pre-drive questionnaire was used to ascertain that drivers were all in good health and were not
 306 receiving any medical treatment. Pre- and post-drive cognitive tests were used to determine if any driver(s)
 307 suffered from any attention lapses due to simulator induced fatigue (Langner et al., 2010; Zhao et al., 2012).
 308 These consisted of measuring reaction times to visual and auditory stimuli by means of an online platform.
 309 Driving experiments were performed in two out of the six possible scenarios (three tracks per two driving
 310 directions), randomly assigned to all 41 participants; the assignment was regulated to guarantee an equal
 311 distribution of drives across each scenario. In the final questionnaire based on a suggestion from Kennedy et
 312 al. (1993), drivers were asked to declare if they had experienced any kind of simulation sickness. Their
 313 negative responses confirmed the effectiveness of the strategies adopted (i.e., training session, simulation
 314 duration, design of road scenarios) to reduce driver discomfort.

315 Longitudinal and transversal behavior data, in terms of speed and lateral displacement, were collected
 316 for each driver involved in the experiment. The lateral position was considered as the transversal distance of
 317 the vehicle center of gravity from the lane centerline, also called “lane gap” (LG). Data were recorded at the
 318 sample rate of 10 Hz, and then filtered in order to consider only free-flow conditions (i.e., excluding
 319 overtaking maneuvers, operations influenced by the vehicle ahead). Speed analysis was restricted to the
 320 circular arc of curved sections, whereas lane gap was observed across the curve, considering 50 m of the
 321 approaching tangent, the entering and exiting spirals, and 50 m of the departure tangent. This measure was
 322 employed to compute the dispersion of trajectory (*DT*), a synthetic indicator of the vehicle position in the
 323 lane, and along a road segment (Calvi, 2015b). The standardized *DT* (DT^S) considers the discrepancies

324 between the adopted trajectory (red line of Figure 5) and the lane centerline (ideal trajectory) as per the
 325 equation:

$$326 \quad DT^S = \frac{\int_{s=0}^{s=L} |LG^*(s)| ds}{L} \quad (4)$$

327 where s is the curvilinear abscissa, and L is the total length of the element.

328

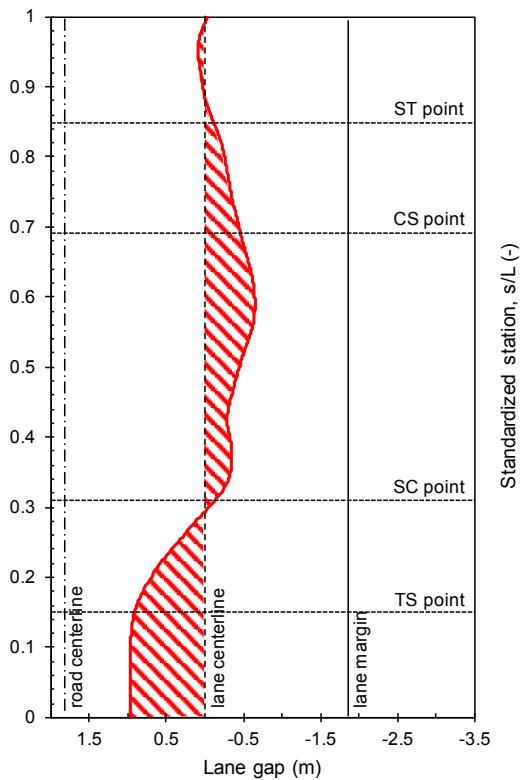

329
 330 **Figure 5.** Scheme of DT^S measurement (red area) along the curved elements and adjacent tangents
 331 (TS = tangent-to-spiral point; SC = spiral-to-curve point; CS = curve-to-spiral point; ST = spiral-to-tangent point).
 332

333 Specifically, the DT^S variable evaluates the ability of the driver to select an appropriate steering angle,
 334 or to follow the correct geometry of the path. Lower values of DT^S suggest that the geometry of the curve is
 335 well perceived (or “read”) by the test driver. Such data has safety implication since they describe the
 336 tendency of certain road alignments to induce frequent trajectory corrections (i.e., wrong steering wheel
 337 control) (McGehee et al., 2004). A pilot study was performed prior to actual data collection to evaluate the
 338 consistency of the experimental protocol, the time optimization during the driving sessions, and the
 339 methodologies for data manipulation and analysis.

340

341 **4. RESULTS**

342 **4.1 Speed vs. Available Sight Distance**

343 The mean (M) and standard deviation (SD) of all the speed values (n) collected along the circular arcs were
 344 estimated and reported in Table 3. The dispersion of speed data around the mean value reflects the variation
 345 in the speeds chosen by participants, results which are also evident in the field as noted by the range of
 346 behaviors and attitudes exhibited by the driving population (Bassani et al., 2014). Data dispersion was also
 347 due to the drivers adjusting their speed along curves.

348 It is worth noting that in the case of R equal to 120 m, SD values are, on average, lower than those for
 349 higher radii. Lower SD values occur for leftward curves without sight obstructions (11.6 km/h), and the
 350 corresponding rightward condition induces a SD of 12.4 km/h, which is close to the lower limit of those
 351 recorded on curves with obstructions (ranging from 12.2 to 14.9 km/h).

352 In the case of curves with a radius equal to or greater than 225 m, the SD values for unrestricted
 353 visibility conditions on rightward curves are lower than those measured in cases where $0 \leq d \leq 3$ m. The
 354 opposite is observed on leftward curves. Finally, as is the case with mean speed (M), the average SD increases
 355 with an increase in the radius, both for right- and leftward curves.

356 Figure 6 exhibits the relationship between the mean speeds (Table 3) and the ASD in curves affected
 357 by sight obstruction(s) only. The different connections between points in the two graphs (Figure 6A and
 358 Figure 6B) reflect two ways to represent data: linking data obtained from experiments carried out with the
 359 same distance *d* (Figure 6A) or linking those obtained from experiments characterized by the same curve
 360 radius (Figure 6B).

361
 362 **Table 3.** Mean (M) and standard deviation (SD) of speed data collected along the entire curve length (*n* is the total
 363 number of data available for that combination of independent variables) for different combinations of radius (R) and
 364 distance of the obstruction from the road edge (*d*) and the lane centerline (*D*). Symbol ∞ indicates that no sight
 365 obstruction was used, so ASD values are assumed to be higher.

R (m)	Leftward curves						Rightward curves					
	d (m)	D (m)	ASD (m)	Speed (km/h)			d (m)	D (m)	ASD (m)	Speed (km/h)		
				M	SD	n				M	SD	n
120	0	7.125	83.76	75.2	14.7	41	0	3.375	56.61	75.2	13.9	41
	1.5	8.625	92.25	74.9	12.2	54	1.5	4.875	68.11	76.0	14.9	52
	3	10.125	100.06	76.3	13.6	65	3	6.375	77.97	74.2	13.1	67
	∞	∞	∞	70.9	11.6	26	∞	∞	∞	75.3	12.4	26
225	0	7.125	114.02	88.4	14.1	55	0	3.375	77.72	81.5	16.4	50
	1.5	8.625	125.52	86.6	13.3	49	1.5	4.875	93.46	82.6	14.7	49
	3	10.125	136.07	87.6	13.7	52	3	6.375	106.93	89.6	12.9	53
	∞	∞	∞	97.2	16.4	13	∞	∞	∞	80.3	11.0	14
300	0	7.125	131.43	96.1	14.7	52	0	3.375	89.80	85.7	17.3	53
	1.5	8.625	144.67	94.8	14.1	51	1.5	4.875	107.98	89.1	14.9	52
	3	10.125	156.81	92.8	16.1	61	3	6.375	123.53	91.0	15.7	68
	∞	∞	∞	95.3	17.6	13	∞	∞	∞	93.0	13.3	14
430	0	7.125	157.11	99.5	15.5	52	0	3.375	107.59	93.5	18.2	55
	1.5	8.625	172.91	99.1	14.4	42	1.5	4.875	129.34	98.0	19.4	37
	3	10.125	187.40	92.2	12.4	52	3	6.375	147.95	102.1	15.4	46
	∞	∞	∞	105.9	19.4	26	∞	∞	∞	98.4	13.9	28

366

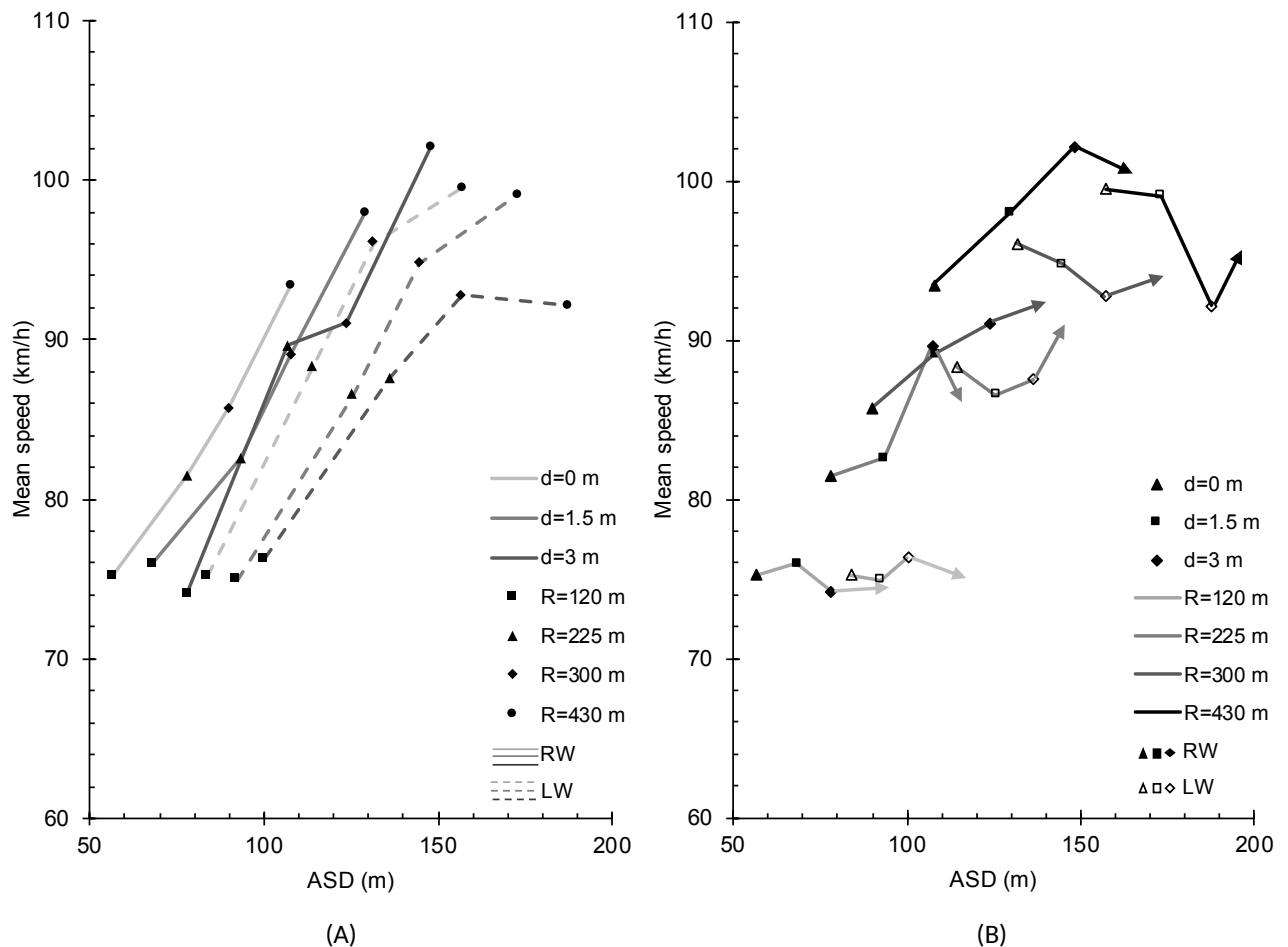

367
368
369
370
371

Figure 6. Relationship between ASD and average speed: data connected on the basis of distance of sight obstruction from the road edge (A), and data connected on the basis of curve radius (B).

372 Figure 6A depicts the direct proportionality between speed and ASD. ASD affected the speed decision
373 of drivers, the evidence for which was observed on both left (dashed lines) and right (continuous lines)
374 curves. For the same ASD value, drivers adopted higher speeds as the distance d of the sight obstruction from
375 the shoulder decreased; this means that the presence of a continuous element on the roadside has a
376 guidance effect on drivers. Nonetheless, drivers were not able to discriminate between driving scenarios with
377 the same ASD and adjusted their speed accordingly, demonstrating that the visual perception of curvature
378 has a significant impact on driver speed choice. These observations were not evidenced by Moreno et al.
379 (2013), since they used a single curve radius (265 m), and an ASD ranging from 109 to 198 m.

380 Along curves with $R = 120$ m, the mean speed remains almost constant even if ASD increases, both on
381 right- and leftward curves (Figure 6B). This confirms that for small radii, there is a strong correlation between
382 speed choice and the curvature captured from the inflection of road markings and roadsides. However, in
383 the case of right curves with radii greater than 120 m, when ASD increases, so does speed while the opposite
384 trend can be observed for left curves. Thus, on curves with the same radius, proximity to the lateral
385 obstruction caused drivers to travel prudently along rightward bends, and faster along leftward ones (only
386 for curves greater than 225 m in radius).

387 Figure 6B also includes the trend for unrestricted sight conditions (arrows on the right of “ $d = 3$ m”
388 series). Without sight obstructions along curves of $R \geq 225$ m, an increase in the average driving speed is
389 evident in the case of left curves. Like previous observations, it is the critical geometry of sharp curves
390 ($R = 120$ m) independently of their ASD values which has the greatest influence over driver speed decisions,
391 a finding which emphasizes once again the relevance of road space guidance elements.

392

393 4.2 Dispersion of Trajectory vs. Available Sight Distance

394 Mean (M) values of DT^S were computed and shown in Table 4, together with the standard deviation (SD) of
395 the values and the number of observations (n) for each curve configuration. In general, the higher the radius,
396 the lower the DT^S observed. These results are consistent with findings by Zakowska (2010). In a few cases,
397 this tendency is reversed: e.g., when $d \geq 3$ m on rightward bends, the observed DT^S corresponding to
398 $R = 300$ m was lower than the one on curves with $R = 430$ m. In these conditions, the perceived distance to
399 the lateral wall increased and diminished the guidance effect provided by the sight obstruction. In contrast,
400 leftward bends are characterized by smaller DT^S values with respect to the corresponding rightward curves
401 with the sole exception of curves with $R = 120$ m, $d = 0$ m and infinite (∞). Therefore, the greater the ASD,
402 the smaller the deviation from the ideal trajectory, albeit only when the sight obstruction was present.

403 Figure 7 exhibits the relationship between the mean dispersion of trajectory and ASD along curves
404 affected by sight obstruction(s), with data presented in Table 4. Data were linked for the same distance d
405 (Figure 7A), and for the same curve radius (Figure 7B).

406 Figure 7A emphasizes the direct proportionality between DT^S and ASD: when ASD increases, the mean
407 dispersion of trajectory decreases. It confirms that a higher ASD leads to an increased tendency to adopt
408 more precise vehicle trajectories, both along leftward (dashed lines) and rightward (continuous lines) curves.
409 It is worth noting that for the same ASD, driver trajectories were characterized by different DT^S : the effect of
410 the radius R on transversal behavior was more evident on right- than on leftward bends. Lower values of DT^S
411 were observed only when the sight limitation was placed near the shoulder ($d = 0$ m) or when the ASD was
412 higher than 150 m. These findings serve to highlight the guidance effect on steering behavior provided by
413 the lateral wall.

414 Referring to Figure 7B, along rightward curves with $R \leq 225$ m, the mean DT^S increases with a higher
415 slope than on curves with a radius of 430 m. Along left-hand curves where ASD was greater than 120 m, the
416 mean values of DT^S range between 0.3 and 0.4 m.

417

418 **Table 4.** Mean (*M*) and standard deviation (*SD*) of dispersion for trajectories collected along the entire curve length (*n*
 419 is the total number of drivers traveling on this kind of curve) for different combinations of radius (*R*) and distance of the
 420 obstruction from the road edge (*d*) and lane centerline (*D*). Symbol ∞ indicates that no sight obstruction was used, so
 421 ASD values are assumed to be higher

<i>R</i> (m)	Leftward curves						Rightward curves					
	<i>d</i> (m)	<i>D</i> (m)	ASD (m)	<i>DT^s</i> (m)			<i>d</i> (m)	<i>D</i> (m)	ASD (m)	<i>DT^s</i> (m)		
				<i>M</i>	<i>SD</i>	<i>n</i>				<i>M</i>	<i>SD</i>	<i>n</i>
120	0	7.125	83.76	0.51	0.19	41	0	3.375	56.61	0.45	0.18	41
	1.5	8.625	92.25	0.50	0.20	52	1.5	4.875	68.11	0.58	0.22	40
	3	10.125	100.06	0.43	0.19	65	3	6.375	77.97	0.66	0.27	26
	∞	∞	∞	0.48	0.20	25	∞	∞	∞	0.46	0.20	26
225	0	7.125	114.02	0.38	0.16	55	0	3.375	77.72	0.43	0.18	23
	1.5	8.625	125.52	0.40	0.19	49	1.5	4.875	93.46	0.54	0.17	12
	3	10.125	136.07	0.36	0.13	52	3	6.375	106.93	0.63	0.21	26
	∞	∞	∞	0.40	0.16	12	∞	∞	∞	-	-	-
300	0	7.125	131.43	0.34	0.13	52	0	3.375	89.80	0.47	0.21	12
	1.5	8.625	144.67	0.38	0.16	51	1.5	4.875	107.98	0.48	0.18	25
	3	10.125	156.81	0.34	0.12	61	3	6.375	123.53	0.46	0.22	41
	∞	∞	∞	0.37	0.16	13	∞	∞	∞	0.45	0.23	14
430	0	7.125	157.11	0.34	0.15	52	0	3.375	107.59	0.36	0.15	41
	1.5	8.625	172.91	0.30	0.14	42	1.5	4.875	129.34	0.42	0.17	26
	3	10.125	187.40	0.34	0.15	52	3	6.375	147.95	0.46	0.21	22
	∞	∞	∞	0.37	0.20	26	∞	∞	∞	0.41	0.20	28

422

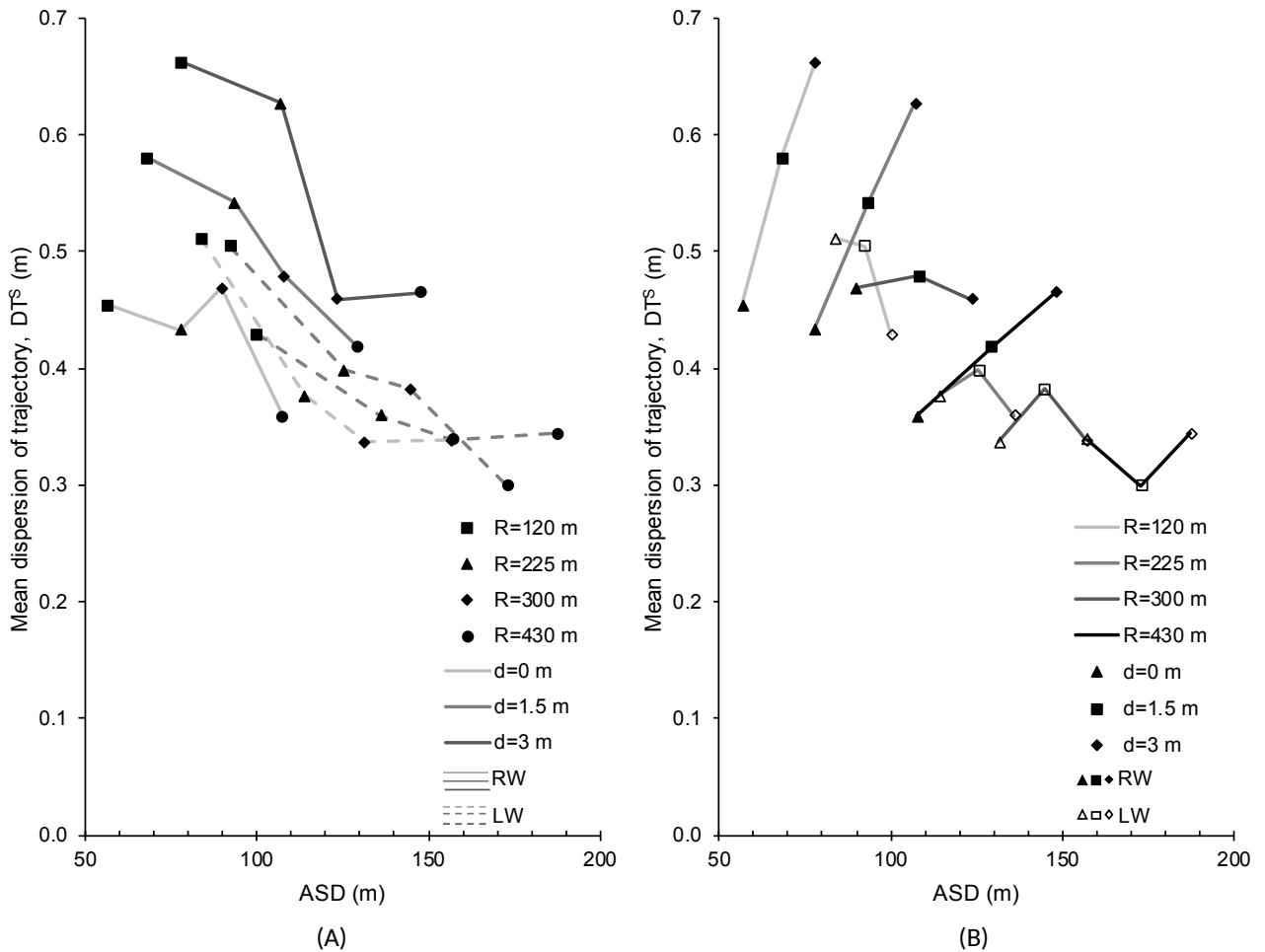

423
 424
 425
 426
 427

Figure 7. Relationship between ASD and trajectory dispersion: data connected on the basis of sight obstruction distance from the road edge (A), and data connected on the basis of curve radius (B)

4.3 Significant variables and interactions

To support the inferences drawn from Figure 6 and Figure 7, ANOVA was performed by using R software (v3.1.1) to evaluate the significance of the investigated variables for the observed data (R Core Team, 2016). In this analysis, the mean speed along each investigated circular curve and the values of the standardized dispersion of trajectory (DT^S) were repeatedly used as measurement variables for drivers.

The ANOVA was performed in two different ways: a 3-way ANOVA in which the main variables were curve direction (*dir*), radius (*R*) and offset of the lateral obstruction from the road edge (*d*); and a 2-way ANOVA with radius (*R*) and the distance between the lane centerline and the sight obstruction (*D*) regarded as the principal variables. The two ANOVAs were carried out to determine whether *d* or *D* had more influence on the driver speed and track behavior; it is worth considering that *D* values include the effects of *d* and curve direction. In the two ANOVAs, eta-squared (η^2) was computed to determine the magnitude of the effects of individual variables. It measures the degree of variance in dependent variables explained by the different groups defined for independent variables (Richardson, 2011). In general, η^2 is more conservative than the partial coefficient since it returns smaller or equal values.

In both cases, the statistical analysis required that datasets be normally distributed, and variances be homogeneous. These assumptions were checked by means of the K-S test and Levene's test, respectively.

4.3.1 Driving speeds

Data shown in Table 3 were subjected to the Chi-squared test assuming a confidence level of 95% ($\chi^2_{crit} = 5.99$). Results revealed datasets were normally distributed (29 of 32 groups for 3-way ANOVA; 26 of 28 groups for 2-way ANOVA). The results of Levene's tests for the 3-way ($DoF = 31$, $F = 1.24$; $p = .174$) and the 2-way ($DoF = 27$, $F = 1.38$, $p = .096$) ANOVAs showed that variances are homogeneous among the dataset.

Table 5 lists the results of the 3-way ANOVA on driving speeds, clearly indicating both the radius ($F(3,1377) = 154.57$, $p < .001$, $\eta^2 = .243$) and the direction of travel ($F(1,1377) = 9.33$, $p = .002$, $\eta^2 = .005$) as the variables with the greatest influence on the operating speed, while the offset of the lateral sight obstruction (*d*) was found to be insignificant ($F(3,1377) = 1.24$, $p > .05$, $\eta^2 = .002$). In fact, the radius accounts for 24.3% of the variation in speed values, with the direction of travel and distance *d* of lateral sight obstruction contributing less than 1%. The offset *d* becomes significant in the interaction with the direction of travel ($F(3,1377) = 5.14$, $p = .002$, $\eta^2 = .008$), which means that the position of the sight obstruction plays a different role when evaluated on left- or right-hand curves. Other interactions between influencing factors are less significant. Lastly, the proportion of speed variance that cannot be explained by design variables is 72%.

In the wake of previous outcomes, the aggregated distance *D* was used instead of the distinguished effects *direction* and *d* to perform a 2-way ANOVA, with the results listed in Table 6. In this case, speed samples were grouped as a function of the four radii and the seven road configurations (six with sight obstructions and one without). The outcomes confirmed the high significance of both *R* ($F(3,1381) = 153.57$,

464 $p < .001$, $\eta^2 = .243$) and D ($F(6,1381) = 4.07$, $p < .001$, $\eta^2 = .013$), while their interaction proved to be fairly
 465 significant ($F(18,1381) = 1.64$, $p < .05$, $\eta^2 = .016$). Results confirm the relative contributions of the radius
 466 (24.3%) and the effective distance D from the sight obstruction (1.3%) to speed variance. The results from
 467 the 2-way ANOVA suggest that the distance between the sight obstruction and driving trajectory was the
 468 significant factor rather than the offset of the same obstruction from the roadway. This outcome reaffirmed
 469 the relevance of ASD when assessing driver behavior.

470

471 **Table 5.** Results of 3-way ANOVA on driving speeds

Principal Effects	Degree of Freedom	Sum of Squares	Mean of Squares	F value	Pr(>F)	η^2
Direction (left/right hand), <i>dir</i>	1	2052	2052	9.334	0.00229	0.005
Radius, <i>R</i>	3	101946	33982	154.567	< 2.2e-16	0.243
Distance, <i>d</i>	3	820	273	1.243	0.29267	0.002
Interaction Effects						
<i>dir</i> * <i>R</i>	3	1952	651	2.960	0.03129	0.005
<i>dir</i> * <i>d</i>	3	3387	1129	5.136	0.00156	0.008
<i>R</i> * <i>d</i>	9	2089	232	1.056	0.39308	0.005
<i>dir</i> * <i>R</i> * <i>d</i>	9	4643	516	2.347	0.01259	0.011
Residuals	1377	302738	220			0.721

472

473 **Table 6.** Results of 2-way ANOVA on driving speeds

Principal Effects	Degree of Freedom	Sum of Squares	Mean of Squares	F value	Pr(>F)	η^2
Radius, <i>R</i>	3	101985	33995	153.5676	< 2.2e-16	0.243
Distance, <i>D</i>	6	5408	901	4.0715	0.00047	0.013
Interaction Effects						
<i>R</i> * <i>D</i>	18	6525	362	1.6375	0.04445	0.016
Residuals	1381	305710	221			0.729

474

475 4.3.2 Dispersion of trajectories

476 Once again, data shown in Table 4 were subjected to the Chi-squared and Levene's tests (level of significance
 477 of 5%). Results revealed datasets were normally distributed (28 of 31 groups for 3-way ANOVA; 27 of 28
 478 groups for 2-way ANOVA); and variances were homogeneous among the dataset ($DoF = 30$, $F = 2.01$, $p = .111$
 479 for 3-way ANOVA; $DoF = 27$, $F = 2.14$, $p = .066$ for 2-way ANOVA).

480 Results for the same analyses with values of DT^5 are presented in Table 7 and Table 8. The outcomes
 481 for the 3-way ANOVA clearly indicate that the direction ($F(1,1072) = 69.31$, $p < 2.6 \cdot 10^{-16}$, $\eta^2 = .053$) and radius
 482 ($F(3,1072) = 31.47$, $p < 2.2 \cdot 10^{-16}$, $\eta^2 = .072$) are the variables which have the most significant influence on
 483 dispersion of trajectory. Distance (d) is less significant ($F(3,1072) = 2.92$, $p = .033$, $\eta^2 = .007$). Once again, the
 484 radius of curvature is the variable which contributes most to the outcome (7.2%), whereas the direction of
 485 travel influences only 5.3% of the dispersion of trajectory variance. The interaction between the direction of
 486 travel and the distance has high significance ($F(3,1072) = 10.17$, $p = 1.3 \cdot 10^{-6}$, $\eta^2 = .023$), which means that the
 487 position of the sight obstruction plays a different role when evaluated on left- or rightward curves.
 488 Furthermore, there is an influence on interaction between the radius and the direction of the curve

489 ($F(3,1072) = 3.34, p < .02, \eta^2 = .008$). The proportion of variance not explained by the considered variables is
 490 about 82%.

491 In light of previous outcomes, the 2-way ANOVA confirms the high significance of both R
 492 ($F(3,1075) = 32.90, p < 2 \cdot 10^{-16}, \eta^2 = .075$) and D ($F(6,1075) = 17.87, p < 2 \cdot 10^{-16}, \eta^2 = .082$), while their
 493 interaction proved to be fairly significant ($F(18,1075) = 1.65, p < .05, \eta^2 = .023$). In this case, the DT^S variance
 494 is associated more with the variation in D (8.2%) than with the variation in R (7.5%). The results of this 2-way
 495 ANOVA are the same as those relating to the driving speed, evidencing that R and D influence longitudinal
 496 and transversal driver behavior. Once again, these results show the relevance of ASD to driver performance.

497
 498 **Table 7.** Results of 3-way ANOVA on dispersion of trajectory (DT^S)

Principal Effects	Degree of Freedom	Sum of Squares	Mean of Squares	F value	Pr(>F)	η^2
Direction (left/right hand), dir	1	2.224	2.22388	69.309	2.542e-16	0.053
Radius, R	3	3.029	1.00962	31.466	< 2.2e-16	0.072
Distance, d	3	0.281	0.09357	2.916	0.03330	0.007
Interaction Effects						
$dir * R$	3	0.321	0.10704	3.336	0.01885	0.008
$dir * d$	3	0.979	0.32617	10.165	1.325e-06	0.023
$R * d$	9	0.308	0.03426	1.068	0.38403	0.007
$dir * R * d$	8	0.483	0.06035	1.881	0.05945	0.011
Residuals	1072	34.397	0.03209			0.819

499

500 **Table 8.** Results of 2-way ANOVA on dispersion of trajectory (DT^S)

Principal Effects	Degree of Freedom	Sum of Squares	Mean of Squares	F value	Pr(>F)	η^2
Radius, R	3	3.164	1.05481	32.8994	< 2e-16	0.075
Distance, D	6	3.438	0.57294	17.8699	< 2e-16	0.082
Interaction Effects						
$R * D$	18	0.952	0.05291	1.6503	0.04238	0.023
Residuals	1075	34.466	0.03206			0.820

501

502 5. DISCUSSION

503 Previous studies investigated the effects of horizontal alignment and cross-sectional factors on the
 504 longitudinal behavior of drivers (Ben Bassat and Shinar, 2011; Bella, 2013; Calvi, 2015b). These works did not
 505 measure the effects associated with variations in the available sight distance (ASD) along curves with limited
 506 visibility; their experimental designs also included roadside elements which have great influence on risk
 507 perception and, consequently, longitudinal and transversal driver behaviors.

508 The main aim of this work was to evaluate if the ASD on its own could influence driver behavior in
 509 terms of preferred speed and trajectory. Weller et al. (2008) postulated that the available sight distance is a
 510 key factor when it comes to driver perception of road type, which in turn has a great influence on driver
 511 preferred speeds and trajectories. In this experiment, ASD values were generated by the placement of a
 512 continuous sight obstruction at different offsets from the lane centerline along curves of different radii (R)

513 within a range from 120 to 430 m (Figure 1). As a result, *R* and *D* were the main design factors in the
514 experiment.

515 Driving speeds were examined by computing the mean speed adopted by participants in the simulation
516 experiment along the circular arc of the curves (which also included spiraled transitions). Results confirmed
517 that the road curvature had the most significant impact on driver preferred speed. However, on sharp curves,
518 the speed choice was affected more by the curvature of the segment than by the ASD (Figure 6b). For higher
519 radii, the effect of the distance from the sight obstruction is also evident on driving speed, leading to
520 increasing values when it (sight obstruction) was moved further away from the vehicle trajectory (for
521 rightward curves only). Conversely, on leftward bends, the speed decreased even when the sight distance
522 increased. Along the investigated interval of alignment radii, results indicated that the relationship between
523 the mean driving speed and the ASD tends to be linear – the greater the ASD, the higher the speed. This
524 result is consistent with the results from field observations by Figueroa Medina and Tarko (2005).

525 The 3-way ANOVA confirmed the influence of the radius on driving speed. As documented in previous
526 studies (Said et al., 2009; Van Winsum and Godthelp, 1996), low curvatures facilitate the adoption of higher
527 speeds since they generate reduced lateral accelerations. Although lateral acceleration cannot be detected
528 on a fixed-base driving-simulator, drivers, drawing on real-life past driving experience, limited their speed on
529 sharp curves. Furthermore, the second factor affecting speeds is curve direction (Table 4); the influence of
530 direction is reduced in the case of sharp curves while it becomes dominant for wider radii, revealing the
531 significance of the interaction between direction and radius.

532 Bella (2013) found significant differences in speed between left - and right-hand curves in the 200 to
533 400 m range, consistent with the findings of this study. Conversely, Calvi (2015b) stated that only radius
534 magnitude affected driver speed choice. The findings from this study confirm the conclusions reached by
535 Bella (2013). However, with respect to Calvi (2015b), any difference with respect to this investigation are
536 attributed to roadside elements used in the various driving scenarios, which influence driver perceived safety
537 levels and trigger specific visual mechanism strategies. In the present study, roadside elements were
538 excluded in order to concentrate solely on the influence of sight obstruction.

539 The results from this work confirmed the hypothesis of the influence of ASD on driver preferred speed
540 along medium and shallow curves. The 3-way ANOVA carried out in this research revealed that the distance
541 of the lateral wall from the road edge did not affect driver preferred speed. In this case, a sight obstruction
542 was placed at three different offsets from the same 1.5 m wide shoulder. In the investigation of Ben-Bassat
543 and Shinar (2011), the traffic barrier was offset by increasing the shoulder width. The average speed on
544 rightward curves increases with an increase in the distance of the barrier from the road edge, while it
545 remained almost constant with different shoulder width values, albeit without the barrier.

546 Driver transversal behavior was analyzed in terms of the lane gap (*LG*) between the travelled path
547 (center of gravity of the vehicle) and the lane centerline, which allows the computation of the trajectory
548 dispersion along the investigated curves. Data were considered across the analyzed bends (including 50 m of

549 approaching and departure tangents, spirals, and circular arc) to investigate the entire curve negotiation. The
550 computation of the standardized dispersion of trajectory (DT^S) confirmed that the accuracy of the trajectory
551 increased for greater radii, and for leftward curves (Van Winsum and Godthelp, 1996; Calvi, 2015b). The
552 trends for DT^S also evidenced the guidance role of the lateral sight obstruction on rightward bends.
553 Specifically, for the same radius of curvature, reduced values were observed when the obstruction was close
554 to the vehicle trajectory. The distance of the driver from the lateral wall (D) had less of an effect than the
555 radius of curvature when negotiating leftward bends. A direct proportionality was also observed between
556 the dispersion of trajectory and the ASD: the greater the ASD, the lower the DT^S .

557 The high values for trajectory dispersion along tight curves could suggest a tendency for participants
558 to “cut” curves (Ben Bassat and Shinar, 2011; Bella, 2013). Although the movement toward the roadside (on
559 rightward curves) is risky for drivers, moving leftward is no less so since it may lead to a head-on collision
560 with vehicles traveling in the opposite direction. This is also in line with previous observations by Boer (1996)
561 and Coutton-Jean et al. (2009), who stated that drivers are prone to adopt the path with the lowest maximum
562 curvature to minimize the centrifugal forces on the vehicle. However, this experiment evidenced that drivers
563 tended to “cut” the leftward bends since this maneuver did not significantly limit their perceived ASD, while
564 they adopted trajectory curvatures close to the design ones thereby not compromising their restricted sight
565 distance. These outcomes derive from an analysis of several sight distance values provided by test drivers,
566 which the previously mentioned works omitted. These results affirm the relevance of visual information that
567 drivers process when negotiating curves, although the simulator used in this experiment did not return any
568 acceleration to participants.

569 The statistical analysis with the ANOVA highlighted the contextual significance of the radius and the
570 offset of the sight obstruction from the lane centerline (D), both on driving speed and on dispersion of
571 trajectory. The 3-way ANOVA confirmed that the offset of the sight obstruction from the road edge (d) did
572 not affect the speed choices, while a limited but nevertheless significant influence was found in the case of
573 dispersion of trajectories only.

574

575 **6. CONCLUSIONS AND RECOMMENDATIONS**

576 This study examined the longitudinal and transversal behavioral response of drivers travelling along curves
577 with limited and unlimited available sight distance (ASD). The road scenarios were designed to produce a
578 constant ASD value along each curve so that the driver response could be evaluated under stationary sight
579 conditions.

580 This investigation demonstrates that drivers adjust their longitudinal behavior and vehicle trajectory
581 under different visibility conditions. From a road designer perspective, a knowledge of the range of possible
582 driver behaviors would help with the adoption of consistent design decisions. It has also been demonstrated
583 that driver behavior can be anticipated and manipulated with a proper geometric design of sight conditions
584 (resulting from the combination of geometric factors associated with road alignment and cross-sectional

585 characteristics), and plausible driving errors and unexpected/undesired behaviors deterred. Consequently,
586 the results of this investigation provide a new insight into the operational and behavioral effects of road
587 geometrics, and more specifically the effects attributable to ASD variations.

588 It is worth noting that the results of this investigation are consistent with the risk compensation theory
589 (Summala, 1996): a greater ASD induces drivers to take higher risks by speeding, which also means that their
590 risk perception changes when ASD changes. Furthermore, the results reported here are consistent with the
591 "self-explaining road" concept and framework (Theeuwes and Godthelp, 1995). In fact, ASD can be
592 modulated to convey a specific message to drivers, for example to compel drivers to assume behaviors
593 consistent with the road category and surrounding environment.

594 Road geometric policy makers should consider ASD as a fundamental parameter and integrate it into
595 operational and road safety analyses. Since ASD affects speed choice along horizontal curves, this variable
596 should be included in future versions of operating speed models (Transportation Research Circular, 2011)
597 currently used in road design consistency analyses.

598 An important practical implication of this research is related to the design of new roads as well as the
599 analysis (and re-design) of existing ones. In both cases, designers should avoid situations in which the ASD is
600 much greater than the RSD. Based on the study results, limiting the ASD to the lowest possible value (but
601 ensuring that $ASD > RSD$ according to standards) is strongly recommended. This design decision will
602 discourage motorists from driving at inappropriate or excessive speeds. However, drivers maintain a greater
603 control of their trajectory at superior ASD values. Accordingly, limitations to the ASD could be used in
604 conjunction with other environmental factors in the quest for a more prudent longitudinal behavior and safer
605 vehicle control.

606 Reliability analysis is, nowadays, one of the solutions promoted as a response to the uncertainties in
607 geometric design and to evaluate the risk(s) associated with particular design choices (Hussein et al., 2014).
608 Thus, the results of this work could be employed in the validation of a risk-based reliability analysis to assess
609 the effectiveness of design guides.

610 This investigation reveals a number of limitations that have to be considered before these results can
611 be transformed into practical applications: (i) the selected road type corresponds to a two-lane highway in a
612 rural environment; (ii) the range of curvature radii employed only considers curves in the 120-430 m; (iii) the
613 range of ASD investigated is greater than 56.6 m; (iv) the road tracks were developed on a flat terrain. As a
614 result, other road types, curve radii, shorter ASD, and vertical alignment design should be examined in future
615 investigations. Furthermore, the contextual presence in the road environment of other road features (i.e.,
616 vertical signals with speed limits, traffic barriers, hazardous elements in the roadside) which were
617 demonstrated in past studies to influence driver behavior in combination with visibility conditions should be
618 carefully evaluated. Despite the significant potential of simulation technology in the performance of
619 experiments where the independent variables are fully controlled, the risk perception with this system is

620 different from that of real driving conditions, so the results of this investigation have to be carefully evaluated
621 in terms of their transferability to real -life driving situations.

622

623 **ACKNOWLEDGEMENTS**

624 The authors wish to thank the voluntary test drivers for their support in this research.

625

626 **REFERENCES**

- 627 AASHTO (2011). *A policy on geometric design of highways and streets, 6th edition*. American Association of
628 State Highway, and Transportation Officials, Washington, D.C. ISBN: 978-1-56051-508-1
- 629 Bassani, M., Catani, L., Ignazzi, A.A., Piras, M. (September, 2018). Validation of a Fixed-Base Driving Simulator
630 to Assess Behavioural Effects of Road Geometrics. In *Proceedings of the DSC 2018 EUROPE^{VR} Driving
631 Simulation Conference and Exhibition (pp. 101 108)*. Antibes, France. ISBN: 978-2-85782-734-4
- 632 Bassani, M., Dalmazzo, D., Marinelli, G., Cirillo, C. (2014). The effects of road geometrics and traffic
633 regulations on driver-preferred speeds in northern Italy. An exploratory analysis. *Transportation Research
634 Part F: Traffic Psychology and Behaviour*, 25, 10-26. doi: 10.1016/j.trf.2014.04.019
- 635 Bella, F. (2013). Driver perception of roadside configurations on two-lane rural roads: Effects on speed and
636 lateral placement. *Accident Analysis and Prevention*, 50, 251-262. doi: 10.1016/j.aap.2012.04.015
- 637 Ben-Bassat, T., Shinar, D. (2011). Effect of shoulder width, guardrail and roadway geometry on driver
638 perception and behavior. *Accident Analysis and Prevention*, 43, 2142-2152. doi:
639 10.1016/j.aap.2011.06.004
- 640 Boer, E. R. (1996, September). Tangent point oriented curve negotiation. In *Proceedings of the Intelligent
641 Vehicles Symposium (pp. 7-12)*. IEEE. doi: 10.1109/IVS.1996.566341
- 642 Brenac, T. (1996). Safety at curves and road geometry standards in some European countries. *Transportation
643 Research Record: Journal of the Transportation Research Board*, No. 1523, 99-106. doi:
644 10.1177/0361198196152300112
- 645 Calvi, A. (2015a). Does Roadside Vegetation Affect Driving Performance? Driving Simulator Study on the
646 Effects of Trees on Drivers' Speed and Lateral Position. *Transportation Research Record: Journal of the
647 Transportation Research Board*, No. 2518, 1-8. doi: 10.3141/2518-01
- 648 Calvi, A. (2015b). A study on driving performance along horizontal curves of rural roads. *Journal of
649 Transportation Safety and Security*, 7(3), 243-267. doi: 10.1080/19439962.2014.952468
- 650 Catani, L., Bassani, M. (2019, January). Anticipatory Distance, Curvature, and Curvature Change Rate in
651 Compound Curve Negotiation: A Comparison between Real and Simulated Driving. In *Proceedings of the
652 98th TRB Annual Meeting*. Washington, D.C.
- 653 Castro, M., Sánchez, J. F., Sánchez, J. A., Iglesias, L. (2011). Operating speed and speed differential for highway
654 design consistency. *Journal of Transportation Engineering*, 137(11), 837-840. doi: 10.1061/(ASCE)TE.1943-
655 5436.0000309
- 656 Castro, M., De Santos-Berbel, C. (2015). Spatial analysis of geometric design consistency and road sight
657 distance. *International Journal of Geographical Information Science*, 29(12), 2061-2074. doi:
658 10.1080/13658816.2015.1037304
- 659 Coutton-Jean, C., Mestre, D. R., Goulon, C., Bootsma, R. J. (2009). The role of edge lines in curve driving.
660 *Transportation Research Part F: Traffic Psychology and Behaviour*, 12(6), 483-493. doi:
661 10.1016/j.trf.2009.04.006
- 662 Figueroa Medina, A. M., Tarko, A. P. (2005). Speed factors on two-lane rural highways in free-flow conditions.
663 *Transportation Research Record*, 1912(1), 39-46. doi: 10.3141/1912-05
- 664 Hussein, M., Sayed, T., Ismail, K., Van Espen, A. (2014). Calibrating road design guides using risk-based
665 reliability analysis. *Journal of Transportation Engineering*, 140(9), 04014041. doi: 10.1061/(ASCE)TE.1943-
666 5436.0000694
- 667 Kennedy, R. S., Lane, N. E., Berbaum, K. S., Lilienthal, M. G. (1993). Simulator sickness questionnaire: An
668 enhanced method for quantifying simulator sickness. *The International Journal of Aviation Psychology*,
669 3(3), 203-220. doi: 10.1207/s15327108ijap0303_3

670 Jamson, S., Lai, F., Jamson, H. (2010). Driving simulators for robust comparisons: A case study evaluating road
671 safety engineering treatments. *Accident Analysis and Prevention*, 42(3), 961-971. doi:
672 10.1016/j.aap.2009.04.014

673 Langner, R., Steinborn, M. B., Chatterjee, A., Sturm, W., Willmes, K. (2010). Mental fatigue and temporal
674 preparation in simple reaction-time performance. *Acta Psychologica*, 133(1), 64-72. doi:
675 10.1016/j.actpsy.2009.10.001

676 Leisch, J. E., Leisch, J. P. (1977). New concepts in design-speed application. *Transportation Research Record*,
677 No. 631, 4-14.

678 Martens, M. H., Compte, S., Kaptein, N. A. (1997). The effects of road design on speed behaviour: a literature
679 review. Deliverable D1 (Report 2.3.1), MASTER Project.

680 McGehee, D. V., Lee, J. D., Rizzo, M., Dawson, J., Bateman, K. (2004). Quantitative analysis of steering
681 adaptation on a high performance fixed-base driving simulator. *Transportation Research Part F: Traffic
682 Psychology and Behaviour*, 7(3), 181-196. doi: 10.1016/j.trf.2004.08.001

683 McGwin Jr, G. (2011). "Independent Variables: The Role of confounding and effect modification". In: Fisher,
684 D. L., Rizzo, M., Caird, J., Lee, J. D. (2011). In *Handbook of driving simulation for engineering, medicine,
685 and psychology*. CRC Press, 15:1-8. ISBN: 978-1-4200-6100-0

686 MIT (1992). Nuovo codice della strada (in Italian). D.L. n.285 of April 30th, 1992, Ministero delle Infrastrutture
687 e dei Trasporti.

688 MIT (2001). *Norme funzionali e geometriche per la costruzione delle strade* (in Italian). D.M. no. 6792 of
689 November 5th, 2001, Ministero delle Infrastrutture e dei Trasporti.

690 MIT (2016). *Conto Nazionale delle Infrastrutture e dei Trasporti: Anni 2014-2015*, Ministero delle
691 Infrastrutture e dei Trasporti, Istituto Poligrafico e Zecca dello Stato S.p.A., Roma, Italy.

692 Moreno, A. T., Garcia, A., Camacho-Torregrosa, F. J., Llorca, C. (2013). Influence of highway three-dimensional
693 coordination on drivers' perception of horizontal curvature and available sight distance. *IET Intelligent
694 Transport Systems*, 7(2), 244-250. doi: 10.1049/iet-its.2012.0146

695 Philip, P., Taillard, J., Klein, E., Sagaspe, P., Charles, A., Davies, W. L., Guilleminault, C., Bioulac, B. (2003).
696 Effect of fatigue on performance measured by a driving simulator in automobile drivers. *Journal of
697 Psychosomatic Research*, 55(3), 197-200. doi: 10.1016/S0022-3999(02)00496-8

698 R Core Team (2016). *R: A language and environment for statistical computing*. R Foundation for Statistical
699 Computing, Vienna, Austria. <http://www.R-project.org/>

700 Richardson, J. T. (2011). Eta squared and partial eta squared as measures of effect size in educational
701 research. *Educational Research Review*, 6(2), 135-147. doi: 10.1016/j.edurev.2010.12.001

702 Said, D., Abd El Halim, A., Hassan, Y. (2009). Desirable spiral length based on driver steering behavior.
703 *Transportation Research Record: Journal of the Transportation Research Board*, No. 2092, 28-38. doi:
704 10.3141/2092-04

705 Sparks, W. J. (1968). The influence of highway characteristics on accident rates. *Public Works*, 99(3), 101-103.

706 Steinauer, B., Trapp, R., Böker, E. (2002). Verkehrssicherheit in Kurven auf Autobahnen.
707 *Straßenverkehrstechnik*, 8, 389-393.

708 Summala, H. (1996). Accident risk and driver behaviour. *Safety Science*, 22(1), 103-117. doi: 10.1016/0925-
709 7535(96)00009-4

710 Theeuwes, J., Godthelp, H. (1995). Self-explaining roads. *Safety science*, 19(2), 217-225. doi: 10.1016/0925-
711 7535(94)00022-U

712 Transportation Research Circular (2011). Modeling operating speed. E-C151 synthesis report. Washington,
713 DC: Transportation Research Board of the National Academies.

714 Unione Nazionale Rappresentanti Autoveicoli Esteri - UNRAE (2016). *L'auto 2015: Sintesi Statistica. Il
715 Mercato Italiano negli ultimi 10 anni* (in Italian).

716 Urbanik II, T., Hinshaw, W., Fambro, D. B. (1989). Safety effects of limited sight distance on crest vertical
717 curves. *Transportation Research Record*, No. 1208, 23-35.

718 van der Horst, R., de Ridder, S. (2007). Influence of roadside infrastructure on driving behavior: driving
719 simulator study. *Transportation Research Record: Journal of the Transportation Research Board*, 2018,
720 36-44. doi: 10.3141/2018-06

721 Van Winsum, W., Godthelp, H. (1996). Speed choice and steering behavior in curve driving. *Human factors*,
722 38(3), 434-441. doi: 10.1518/001872096778701926

- 723 Weller, G., Schlag, B., Friedel, T., Rammin, C. (2008). Behaviourally Relevant Road Categorisation: a Step
724 Towards Self-explaining Rural Roads. *Accident Analysis and Prevention*, 40(4), 1581-1588. doi:
725 10.1016/j.aap.2008.04.009
- 726 Zakowska, L. (2010). Operational and safety effects of transition curves in highway design-A driving simulator
727 study. In *4th International Symposium on Highway Geometric Design, Polytechnic University of Valencia,*
728 *Transportation Research Board.*
- 729 Zhao, C., Zhao, M., Liu, J., Zheng, C. (2012). Electroencephalogram and electrocardiograph assessment of
730 mental fatigue in a driving simulator. *Accident Analysis and Prevention*, 45, 83-90. doi:
731 10.1016/j.aap.2011.11.019