

A novel pneutronic device for the investigation of compression-induced physiological phenomena:
Modeling and experimental testing

Original

A novel pneutronic device for the investigation of compression-induced physiological phenomena: Modeling and experimental testing / Ferraresi, Carlo; DE BENEDICTIS, Carlo; Maffiodo, Daniela; Franco, Walter; Messere, Alessandro; Pertusio, Raffaele; Roatta, Silvestro. - ELETTRONICO. - 65:(2019), pp. 207-215. (MESROB 2018 Cassino (Italia) 4-6 luglio 2018) [10.1007/978-3-030-00329-6_24].

Availability:

This version is available at: 11583/2714781 since: 2023-10-13T10:11:57Z

Publisher:

Springer Netherlands

Published

DOI:10.1007/978-3-030-00329-6_24

Terms of use:

This article is made available under terms and conditions as specified in the corresponding bibliographic description in the repository

Publisher copyright

Springer postprint/Author's Accepted Manuscript

This version of the article has been accepted for publication, after peer review (when applicable) and is subject to Springer Nature's AM terms of use, but is not the Version of Record and does not reflect post-acceptance improvements, or any corrections. The Version of Record is available online at: http://dx.doi.org/10.1007/978-3-030-00329-6_24

(Article begins on next page)

A novel pneumatic device for the investigation of compression-induced physiological phenomena: modeling and experimental testing

Carlo Ferraresi¹[0000-0002-9703-9395], Carlo De Benedictis¹[0000-0003-0687-0739], Daniela Maffiodo¹[0000-0002-5831-8156], Walter Franco¹[0000-0002-0783-6308], Alessandro Messere²[0000-0003-1146-2916], Raffaele Pertusio², Silvestro Roatta²[0000-0001-7370-2271]

¹ Department of Mechanical and Aerospace Engineering, Politecnico di Torino, Italy

² Department of Neuroscience, University of Torino, Italy

carlo.ferraresi@polito.it

Abstract. An automatic pneumatic system designed to investigate the physiological effects induced by limb compressions, able to apply customizable pressure patterns in the physiologic range (0-200 mmHg), is here presented. A mathematical model, simulating the whole pneumatic system and its interaction with the limb is described. The model is validated by means of experimental tests. An on-going study aiming to investigate the role of different factors in the development of post compression hyperemia is presented.

Keywords: pneumatic system, pressure control, hyperemia stimulation, muscle compression, human-machine interaction.

1 Introduction

Intermittent pneumatic compression (IPC) is a technique that has been variously investigated in the biomedical field [10, 11] and that can be used for several rehabilitative applications, for example after sports injuries [13] or for the treatment of lymphoedema [6]. The IPC devices are also used in case of patients forced to immobility thanks to the effects that the IPC can exert on the cardiovascular system. When the motor capacity is compromised, the forced inactivity involves regressive phenomena affecting the cardiovascular system. In recent years, several studies tried to understand how to prevent systemic pathological conditions in these cases, and it has been demonstrated that some positive effects can be achieved with the IPC, through an active, correctly conceived biomechanical device that imitates the muscular pump function on the veins of the lower limbs by exerting coordinated pressure stimulations starting from the foot along the leg [2, 7]. This technique is therefore able to increase venous blood flow in case of immobility and to restore cardiovascular efficiency; but there is still a lack of knowledge of the parameters with which such therapy must be applied to achieve positive effects. Proper modeling of the pneumatic system and its interaction with humans can help the improvement of an IPC device [3, 4].

In addition, cardiovascular research is recently focusing on a previously neglected mechanism: i.e. the rapid dilatation that is evoked by a compressive stimulus [8, 9],

for the relevant implications of the ensuing rapid hyperemia in IPC treatments [12]. Different underlying mechanisms have been hypothesized, including compression-induced changes in vascular filling and transmural vessel pressure and deformation of the vascular wall. The possibility to customize compressive stimuli with the addition of pre- and post-compression levels could help to discriminate the relevant factors.

Currently there is no commercially available device that can apply compressive stimuli with a desired pressure pattern, i.e. including long-lasting, low-pressure conditions as well as sharp high-pressure stimuli, with a good compromise between static performance in terms of accuracy, and dynamic performance in terms of response time.

Aim of the present study is to implement and model a new pneumatic system able to apply a customizable pressure pattern to the limb in the physiologic range (0-200 mmHg). The definition of an analytical model has been fundamental because of the demanding and particular requirements of such device, so as to define the specifications of the system and evaluate its performance. An application is then presented in which such pressure patterns are employed in healthy subjects to investigate the determinants of the compression-induced hyperemia

2 Experimental pneumatic system

The study has been carried out by means of an experimental pneumatic system, made up of a sleeve that must be wrapped around the area of the limb to be stimulated, and a proper control circuit. The most demanding specification was the ability to control the pressure of the sleeve with a step reference between 0 and 200 mmHg, with a good compromise between static performance in terms of accuracy (≤ 10 mmHg), and dynamic performance in terms of response time (≤ 0.3 s).

The design of the experimental system had to meet several contradictory requirements. In order to minimize the static error, it would be preferable to use pressure proportional valves with a regulation range comparable to that of the application. For our application these types of valves are normally of small size, and have therefore low maximum flow rate, which implies long sleeve inflation times, considering that the sleeve volume is about 1 dm^3 . Regarding the regulation range, the pressure proportional valve SMC IT0010 would be an appropriate solution, presenting an appropriate set pressure range from 0.001 to 0.1 MPa (7.5-750 mmHg), with good static characteristics (linearity $\leq 1\%$ full scale F.S.; hysteresis $\leq 0.5\%$ F.S; repeatability $\leq 0.5\%$ F.S), and proper dynamic characteristics (response time 0.1 s). On the other hand, its maximum flow rate is only $6 \text{ dm}^3/\text{min}$ (Standard Reference Atmosphere ANR), that means a very long sleeve inflation time of about 10 s.

Vice versa, pressure proportional valves able to regulate higher pressure ranges are of greater size, and therefore suitable in terms of flow performances, but with inadequate accuracy for the application. Moreover, they often are unable to regulate the relative pressure at low values close to zero. For example, the pressure proportional valve SMC ITV1010 would provide a significantly higher maximum flow rate ($200 \text{ dm}^3/\text{min}$ ANR), but it has an inadequate adjustment range, being unable to regulate

the pressure below 0.005 MPa (37.5 mmHg). Therefore, it is not possible to achieve a good compromise between static and dynamic performance using only one commercial pressure proportional valve.

In order to overcome this issue, the pneumatic circuit of Figure 2 has been designed. A 2/2 digital solenoid valve DV1 (direct operated solenoid normally closed valves, two ports two positions 2/2 SMC VXE2330-02F-6D01) supplies at 1.3 bar the sleeve during the transient phase, in order to minimize the inflate response time of the device. Another 2/2 digital solenoid valve (same model) DV2 is employed to discharge the sleeve during the corresponding transient phase, so as to minimize the deflate response time. A small size pressure proportional valve (SMC ITV0010) PPV is supplied at 1.8 bar for the accurate regulation of the sleeve pressure in stationary condition. A pressure transducer PT (BP-1, WPI, Sarasota USA) measures the pressure inside the sleeve, providing a feedback to the control system.

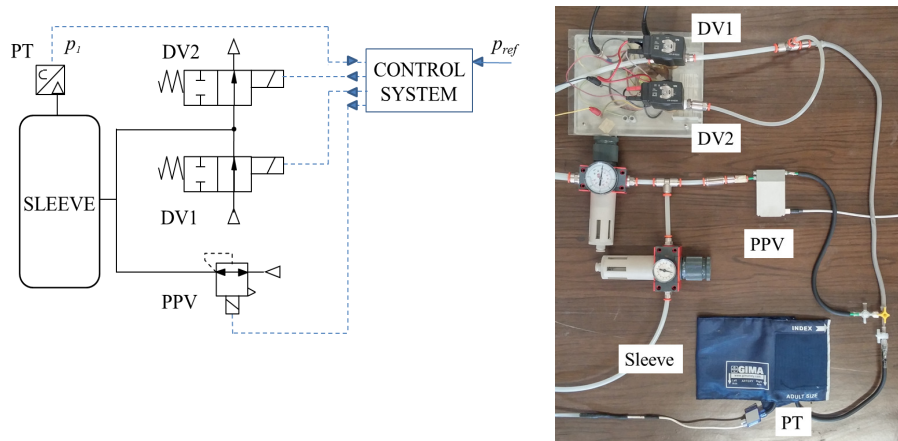

Fig. 1. The pneumatic system for hyperemia stimulation: DV1 - 2/2 digital solenoid valve for sleeve supply; DV2 - 2/2 digital solenoid valve for sleeve discharge; PPV - pressure proportional valve; PT - pressure transducer.

The control system compares the actual pressure value p_1 from the pressure transducer to a reference value p_{ref} and, by means of a PID logic, sends the corresponding command signals to the digital valves DV1 and DV2 and to the proportional valve PPV.

3 Model of the system

The core of the system consists of two 2/2 digital solenoid valves working in coordination with a pressure proportional valve. The control logic provides the appropriate commands to the valves, in order to perform the inflating and deflating of the deformable sleeve meanwhile the desired level of pressure is reached. In order to consider its irregular inflating/deflating, which occur progressively starting from the single air

inlet/outlet, the sleeve has been modeled as the series of two chambers with variable volume, connected by a conveniently tuned pneumatic resistance [1] (Fig. 2).

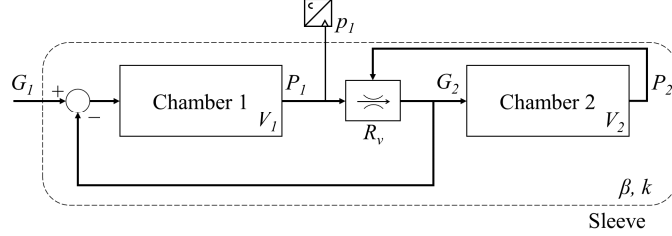

Fig. 2. Model of the sleeve.

Such discretization has been chosen to reproduce the non-uniform deformation of the sleeve volume due to the change of the internal pressure and the interaction with the human tissues, as evidenced experimentally. The variation of the inner pressure of each chamber is affected by the mechanical characteristic of the sleeve and of the limb soft tissues, and can be considered as the resultant of an elastic deformation and a viscous effect depending on the rate of volume change, as reported in Equation (1):

$$p = k(V - V_i) + \beta \frac{dV}{dt} \quad (1)$$

where p is the variation of the relative pressure, V_i is the initial volume and V is the actual volume. β and k are the viscous constant and stiffness representing the viscoelastic behavior of both sleeve and limb tissues, defined by appropriate tuning of the model, also considering the expected volume change at maximum relative pressure.

The relationships between the mass flow rates and the pressures inside each chamber are described by the continuity Equations (2):

$$G_1 - G_2 = \frac{V_{i1} + \frac{p_1}{k} - \frac{\beta}{k} \frac{dV_1}{dt}}{RT} \frac{dP_1}{dt} + \frac{P_1}{RT} \frac{dV_1}{dt}, \quad G_2 = \frac{V_{i2} + \frac{p_2}{k} - \frac{\beta}{k} \frac{dV_2}{dt}}{RT} \frac{dP_2}{dt} + \frac{P_2}{RT} \frac{dV_2}{dt} \quad (2)$$

where 1 refers to the first chamber, whose internal pressure is measured to provide a feedback signal to the control system, and 2 refers to the second chamber. For each chamber, P is the absolute internal pressure and G is the mass flow rate of air. T and R represent respectively the chambers temperature and the air constant. The absolute pressures in both chambers are related by Equation (3):

$$P_1 - P_2 = R_v G_2 \quad (3)$$

where R_v is the value of a pneumatic resistance connecting the volumes.

Each digital valve has been modeled as a pneumatic resistance, according to the ISO 6358 [1]. The mass air flow passing through the valve can be calculated in sonic or subsonic condition depending on the ratio between the downstream and upstream pressures, as presented in Equation (4):

$$G = \rho_0 P_{us} C \text{ for } 0 < \frac{P_{ds}}{P_{us}} \leq b, \quad G = \rho_0 P_{us} C \sqrt{1 - \left(\frac{P_{ds} / P_{us} - b}{1 - b} \right)^2} \text{ for } b < \frac{P_{ds}}{P_{us}} \leq 1 \quad (4)$$

where P_{us} is the upstream absolute pressure, P_{ds} is the downstream absolute pressure, C is the sonic conductance, b is the critical ratio and ρ_0 is the air density in normal conditions. The C and b parameters have been defined respectfully of the data reported by the manufacturer (Table 1). The valve on-off status is controlled with a digital command generated by the control logic, which compares the measured sleeve pressure to selected thresholds. A first order dynamics (with time constant τ_v) has been introduced to take into account the finite response time between the command signal and the resulting variation of conductance. The upstream and downstream pressures for each valve depend on the physical connection of the device: i.e. the digital valve DV1 used to inflate the sleeve has the upstream set as supply pressure, and the P_I pressure set as the downstream one (Fig. 1).

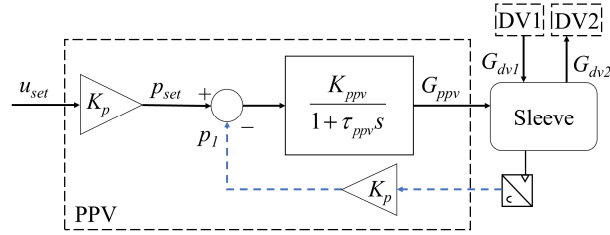

Fig. 3. Model of the pressure proportional valve.

The pressure proportional valve has been modeled as a first order system [5], whose output mass flow rate G_{ppv} depends on the error between the measured pressure p_I and the set pressure p_{set} , the latter provided by the control system. Figure 3 shows the internal pressure control loop of the device. The overall mass flow rate G_I (Fig. 2), defined as positive when directed towards the sleeve, is given by the algebraic sum of the G_{ppv} flow rate and the ones regulated separately by the two digital valves DV1 and DV2, respectively used to inflate (G_{dv1}) and deflate (G_{dv2}) the sleeve. The K_p gain, used to convert the voltage command u_{set} in the required pressure for the proportional valve, is equal to the gain of the transducer performing the measurement of the sleeve internal pressure. The static gain of the valve K_{ppv} has been calculated since the data given by the manufacturer of the device. The main parameters of the system are presented in Table 1. The model of the system has been implemented in MATLAB-Simulink®.

Table 1. Parameters of the system.

Parameter	Value	Parameter	Value
V_{i1}	22 cm ³	τ_v	30 ms
V_{i2}	22 cm ³	τ_{ppv}	25 ms
β	1 kPa s/m ³	K_p	20 kPa/V
k	4.06 MPa/m ³	K_{ppv}	$9.22 \cdot 10^{-9}$ kg/(Pa s)
R_v	3.5 MPa s/kg	R	287.1 J/(kg K)
C	$2.3 \cdot 10^{-8}$ Nm ³ /(Pa s)	T	293 K
b	0.46	ρ_0	1.188 kg/m ³

4 Comparison between experimental tests and model results

Simple patterns were created with the above-described pneumatic circuit (Fig. 1) and compared to the simulations results, in order to validate the model.

To this aim, the sleeve was applied to the calf of 3 healthy subjects, sitting upright. Figure 4 shows the model and the experimental results in case of a simple pattern obtained with the following law:

- digital valve DV1 and pressure proportional valve PPV switched on with a set value of 50 mmHg, the control system stops this phase when set value is reached;
- DV1 switched off, set value kept as constant by the PPV up to 25 s;
- PPV switched off, DV2 switched on;
- rest phase with all valves switched off.

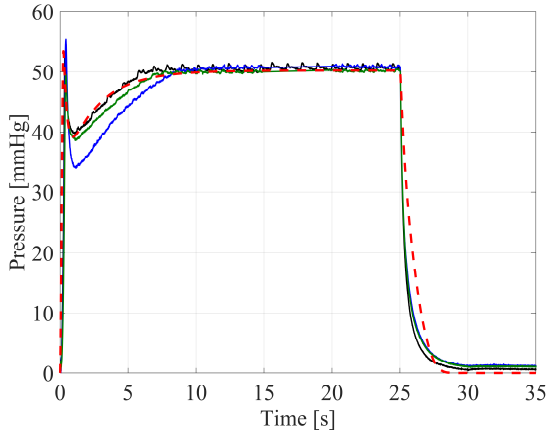

Fig. 4. Pressure inside the sleeve p_1 , comparing the model (dashed line) and the experimental responses (solid lines). The experimental curves have been obtained on three different subjects.

As shown in Figure 4, the model response is sufficiently close to the experimental pressure signals measured by the transducer inside the sleeve. The rise time is similar in both cases, while the deflating phase of the real system appears to be faster than the model. This may be due to inaccuracies in the modeling of the sleeve, concerning the relationship between the variation of the internal pressure and the deformation of each

chamber. Nevertheless, the differences between model and real system are limited and related to time intervals significantly shorter than the duration of each trial.

Both the model and the real system are able to keep a constant level of pressure set to 50 mmHg. This result is of course more relevant referring to the real system, as any losses in the pneumatic circuit need to be handled in such stationary condition by the PPV. The two-chambers modeling scheme (Fig. 2) allows to reproduce the dynamic behavior of the sleeve with sufficient accuracy, also exhibiting the drop of pressure level occurring at the end of the first phase (when DV1 is turned off), as highlighted by the experimental curves. As observed by preliminary analyses, a single chamber model could not be able to reproduce the same behavior.

5 Experimental study on healthy subjects

The proposed device is currently employed in an experimental study on healthy subjects carried out at the Integrative Physiology Lab, Dept. of Neuroscience, University of Torino, to investigate the role of different factors in the development of post-compression hyperemia. For this specific study, various patterns for the lower limb compression were required: a) single compression at 10-50 mmHg lasting 50 s, b) a short compression at 200 mmHg, lasting 1 s, and c) complex compression patterns consisting of a combination of the formers. During these compressions, the blood flow of the femoral vein and the femoral artery was measured by Doppler sonography (MyLab 25, ESAOTE). The sleeve is positioned around the left leg of the subject, placed horizontally. It is particularly important that the pressure is accurately kept constant during the stationary periods and that the changes from one state to another are very rapid to improve repeatability and temporal-localization of the stimuli.

Figure 5 shows an example of a test performed with pattern c). The bottom plot shows pressure p_l acquired by the transducer. The upper part of Figure 5 shows the flow pattern in the femoral artery registered by the eco-doppler probe. A significant increase of the flow is evident, after the 200 mmHg impulse.

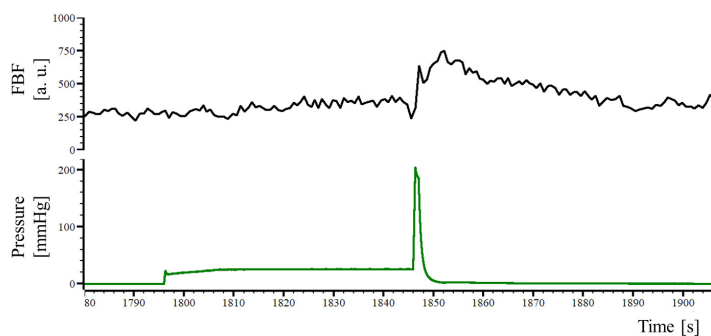

Fig. 5. Original recordings of a post-compression hyperemia from a representative subject: femoral artery blood flow (FBF) and sleeve pressure.

6 Conclusions

A pneumatic system able to apply a customized pressure pattern for the compression of a limb in the range (0-200 mmHg) is here presented. The system is aimed at evoking hyperemia in the stimulated area of a limb, and has been conceived in order to deeply investigate this phenomenon and define proper and effective clinical protocols. No commercial device able to operate in this way is currently available. This application dictated several specifications particularly demanding for a normal pneumatic device, therefore it was necessary to develop a system combining high-power digital valves together with small size high-accuracy pneumo-electronic components.

The system has been studied and optimized by means of a mathematical model, which was then validated through comparison with the results of experimental tests. Particular accuracy has been devoted to modeling of the human-machine interaction: viscous-elastic parameters have been included in the definition of the sleeve structure, this latter has been modeled as a two-stage collapsible volume, to fit experimental data collected during cuff inflation.

This pneumatic system is particularly useful for investigating the physiological response of vessels to mechanical compression, because its very sharp pressure changes allow for precise temporal localization of the compressive stimulus and assessment of the latency of the vascular response.

Moreover, the precise holding of steady pressure levels for any period of time can be useful to investigate the effects of reducing vascular filling in venous compartments and of altering vascular transmural pressure levels on limb perfusion and on the hyperemic response to compression.

By combining the experimental characterization and the numerical simulations, the tuning of the device and of the control logic parameters made it possible to obtain the right compromise between these specifications.

The new possibilities offered by the present system found immediate application in research studies investigating the mechanisms behind the compression-induced hyperemia and will possibly lead to the optimization of clinical protocols and treatments based on pneumatic limb compression.

References

1. C. Ferraresi, "Modelling of pneumatic systems", *Fluid Apparecchiature Idrauliche & Pneumatiche*, vol. 346, pp. 48–54, 1993.
2. C. Ferraresi, H. Hajimirzaalian, and D. Maffiodo, "Identification of physical parameters in a robotized IPC device interacting with human", *Applied Mechanics and Materials*, 490-491, pp. 1729-1733, 2014.
3. C. Ferraresi, D. Maffiodo and H. Hajimirzaalian, "A model-based method for the design of intermittent pneumatic compression systems acting on humans". *Proceedings of the Institution of Mechanical Engineers, Part H: Journal of Engineering in Medicine*, vol. 228, no. 2, pp. 118-126, 2014.

4. C. Ferraresi, D. Maffiodo and H. Hajimirzaalian, "Simulation and control of a robotic device for cardio-circulatory rehabilitation", *Advances in Intelligent Systems and Computing*, vol. 371, pp. 357-365, 2016.
5. C. Ferraresi and M. Sorli, "Modelling and analysis of pressure control systems", *Fluid Apparecchiature Idrauliche & Pneumatiche*, vol. 357, pp. 58-65, 1994.
6. K. Johansson, E. Lie, C. Ekdahl and J. Lindfeldt, "A randomized study comparing manual lymph drainage with sequential pneumatic compression for treatment of postoperative arm lymphedema", *Journal of Lymphology*, vol. 31, pp. 56 - 64, 1998.
7. D. Maffiodo, G. De Nisco, D. Gallo, A. Audenino, U. Morbiducci and C. Ferraresi, "A reduced-order model-based study on the effect of intermittent pneumatic compression of limbs on the cardiovascular system", *Proceedings of the Institution of Mechanical Engineers, Part H: Journal of Engineering in Medicine*, vol. 230, no. 4, pp. 279-287, 2016.
8. A. Messere, G. Ceravolo, W. Franco, D. Maffiodo, C. Ferraresi and S. Roatta, "Increased tissue oxygenation explains the attenuation of hyperemia upon repetitive pneumatic compression of the lower leg", *J Appl Physiol*, vol. 123, pp. 1451-1460, 2017.
9. A. Messere, M. Turturici, G. Millo and S. Roatta, "Repetitive muscle compression reduces vascular mechano-sensitivity and the hyperemic response to muscle contraction", *J Physiol Pharmacol*, vol. 68, pp. 427-437.
10. R.J. Morris, "Intermittent pneumatic compression – systems and applications", *Journal of Medical Engineering and Technology*, vol. 32, n. 3, pp. 179 - 188, 2008.
11. H. Partsch, "Intermittent pneumatic compression in immobile patients. *International Wound Journal*", vol. 5, n. 3, pp. 389 - 397, 2008.
12. R.D. Sheldon, B.T. Roseguini, M.H. Laughlin and S.C. Newcomer, "New insights into the physiologic basis for intermittent pneumatic limb compression as a therapeutic strategy for peripheral artery disease". *J Vasc Surg*, vol. 58, pp. 1688-1696, 2013.
13. T. Waller, M. Caine and R. Morris, "Intermittent Pneumatic Compression Technology for Sports Recovery", *The Engineering of Sport*, vol. 3, 2006.