

Prognostics of onboard electrohydraulic servomechanisms: Proposal of a novel model-based fault detection neural technique

Original

Prognostics of onboard electrohydraulic servomechanisms: Proposal of a novel model-based fault detection neural technique / Dalla Vedova, Matteo D. L.; Cerqua, Gianluca; Maggiore, Paolo. - ELETTRONICO. - (2017), pp. 99-106. (2017 2nd International Conference on System Reliability and Safety Milan, Italy 20-22 Dec. 2017) [10.1109/ICSRS.2017.8272803].

Availability:

This version is available at: 11583/2704230 since: 2018-03-28T15:08:35Z

Publisher:

IEEE

Published

DOI:10.1109/ICSRS.2017.8272803

Terms of use:

This article is made available under terms and conditions as specified in the corresponding bibliographic description in the repository

Publisher copyright

IEEE postprint/Author's Accepted Manuscript

©2017 IEEE. Personal use of this material is permitted. Permission from IEEE must be obtained for all other uses, in any current or future media, including reprinting/republishing this material for advertising or promotional purposes, creating new collecting works, for resale or lists, or reuse of any copyrighted component of this work in other works.

(Article begins on next page)

Prognostics of Onboard Electrohydraulic Servomechanisms: Proposal of a Novel Model-Based Fault Detection Neural Technique

Matteo D. L. Dalla Vedova Gianluca Cerqua Paolo Maggiore
Department of Mechanical and Aerospace Engineering
Politecnico di Torino
Corso Duca degli Abruzzi 24, Italy
matteo.dallavedova@polito.it

Abstract— The paper aims to propose a new prognostic procedure centered on the characterization of the state of health of an electrohydraulic servomechanism typically used in aircraft primary flight controls. This approach is based on the innovative use of a model based fault detection and identification method (FDI) that applies artificial neural network in order to identify the actual state of wear of the actuator. The considered case study concerns an electrohydraulic actuator with a flapper-nozzle servo-valve whose progressive faults taken into consideration are: the clogging of the first stage of the flapper-nozzle valve, and the progressive gain loss of the torque motor. By means of the extraction of data from the system responses, under different extent of damage, multiple neural networks have been trained. Such networks have been integrated to create the prognostic method that has finally been tested under different conditions.

Keywords - prognostics; electrohydraulic actuator; servo-valve; artificial neural network; model-based; fault detection algorithm

I. INTRODUCTION

The ever green solution of the electrohydraulic actuator (EHA) applications for the actuation of modern primary flight commands, justified by the superiority of hydraulic systems in providing more efficient solutions for power supplying in a controlled manner [1-2], brings us to focus on the need of efficient and reliable EHA.

As regards the second aspect, reliability of modern systems is even more based on the proper support of diagnostics and prognostics [3]. Right now, in fact, the last two are the most robust instruments which mitigate life cycle costs without losing reliability and guarantee, in compliance with regulations, the bases for health management of integrated components, subsystems and systems [4].

The principal aim of an onboard primary flight controls servo-actuator is to convert the different power sources available, depending on the general concept of design (mechanical, electrical, hydraulic or pneumatic source), into a controlled motion of specific parts of the aircraft in order to meet operative requirements. The most common and intuitive application of servo-actuators is the controlled movement of mobile surfaces of the aircraft for the actuation of the aircraft flight mechanics.

The last application is an example of high level of risk associated to the functions of a servo-actuator, and suggests how the reliability must be kept in care when airworthiness and safety are involved by regulations. Right now, the unquestionable solution to guarantee an adequate level of reliability was delivered both with a proper design and with the scheduling of a rigorous program of maintenance that should guarantee that an actuation system continues to operate safely. The scheduling of costly maintenance is not related to the effective conditions of wear of the actuator, but just to the expectations of degradation related to the system lifetime previsions. On the other hand, extreme and unexpected operative scenarios may lead to damage and unscheduled maintenance. Therefore, this type of approach in some cases could lead to unacceptable risk to use damaged system, or the increasing of the cost to maintain operative systems that in a good state. An alternative strategy to perform an efficient maintaining procedure could consist in monitoring the functional parameters of the system and to determine its state of health by observing and studying the deviation of its response from the nominal one, and, in general, to get evidence of an anomalous behavior.

The prediction of this kind of failures should be guaranteed, once more, at a high level of reliability. The practice of monitoring and analyzing the system response, through electrical signal acquisition, evaluating the fault is the goal of the Prognosis and Health Management (PHM), as reported by Byington, Watson, Edwards, & Stoelting [5]. In general, prognostics purpose is to perform an early fault detection and identification (FDI) and, then, to provide real-time data on the current status of the system and to calculate the Remaining Useful Life (RUL) before a fault occurs or a component becomes unable to perform its functions at a given level [3]. In the aerospace disciplines, prognostic strategies are often applied to onboard equipment (that are typically non-linear mechatronic systems) and, through the monitoring of some functional parameters of the component involved, they have to predict progressive failures at an early stage and to determine the source of irregular behaviors.

Therefore, literature proposes a wide range of fault detection and identification (FDI) strategies [6]; among these, it is possible to mention model-based techniques based upon the direct comparison between real system and related

monitoring model [7-10], on the spectral analysis of well-defined system behaviors performed by Fast Fourier Transform FFT [11-12], on appropriate combinations of these methods [13] or on Artificial Neural Networks [14-15].

It must be noted that concepts and results reported in this paper are related to the design of a reliable and fast FDI routines focused on the diagnosis model-based approach and, in particular, on the parametric estimation task.

II. AIM OF THE WORK

The aim of this paper is to present an innovative way to perform the diagnosis of an EHA equipped with flapper-nozzle servo-valve (SV). In particular, the procedure is able to identify a plausible damage condition, consisting in two dimensionless parameters corresponding to the extent of the fault modes cross-checked with one out of four level of damage. With a high confidence level, these results represent the real state of damage of the entire system.

As anticipated before, this prognostic method relies on multiple artificial neural networks (ANNs) each one trained with a series of coupled vectors of input and target. Each ANN is specialized in a particular recognition task.

III. EHA REFERENCE MODEL

The considered actuation system (Fig. 1) is a typical electrohydraulic position servomechanism (SM) widely used both in primary and secondary aircraft flight controls. According to [16], the considered EHA consists of three main subsystems:

- Controller subsystem: the control electronics may be a computer, microprocessor or guidance system and creates a command input signal; the servo-amplifier (SA) provides a low power electrical actuating signal which is the difference between the command input signal and the feedback signal generated by the feedback transducer. The SA usually implements an embedded PID control logic (proportional-integral-derivative); it must be noted that, in several applications, it is possible to implement more simplified control logics. The present work is referred to simple proportional control logic.
- Electrohydraulic two stage servo-valve (SV): responds to the SA low power electrical signal and controls the high pressure hydraulic fluid [9].
- Hydraulic piston (symmetrical double acting linear cylinder subject to Coulomb friction): actuates the flight control surface closing the position feedback loop by means of a network of position transducers.

Wider descriptions of the servomechanism employed in this work and of its mathematical model are shown by Maggiore et al. in [11]. The aforesaid servomechanism belongs to the fly-by-wire paradigm: the pilot's command depends upon transducers that express the pilot orders by an electric or a digital reference signal.

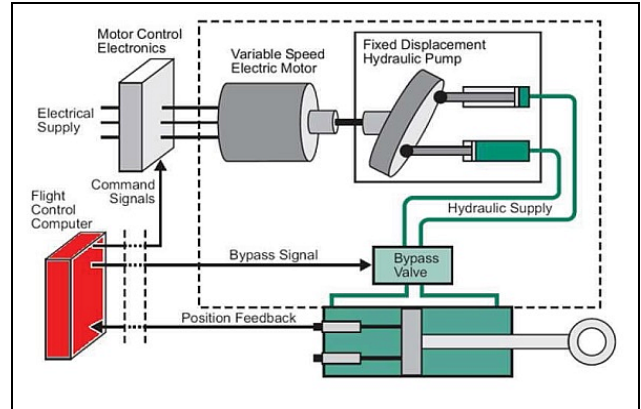

Figure 1. Schematic of the considered EHA layout.

This signal is continuously compared via a feedback loop with the actual position of the control surface generating the instantaneous position error as an input to the control law. Thus, the error is processed and transformed into an electric current operating the electrohydraulic servo-valve. This SV drives an actuator that continuously moves the control surface pursuing the reduction of the error between pilot's commanded position and flight surface actual position.

The servo-valve is a high performance two-stage valve (Fig. 2); its second stage is a closed center, four-way, sliding spool, while the pilot stage is a symmetrical double nozzle and flapper, driven by a torque motor. Since its natural frequency is supposed to be orders of magnitude higher than the desired closed loop bandwidth of the whole SM, only its orifices resistive effects were taken into account.

In the present paper, the hydraulic linear actuator is a double acting symmetrical type. It has been modelled considering inertia, viscous friction, dry friction (according to [17-18]) and leakage effects through the piston seals developing a not working flow. It is also able to take into account the effects due to its interactions with the mechanical ends of travel as well as the aerodynamic loads acting on the flight surface (as proposed in [19]).

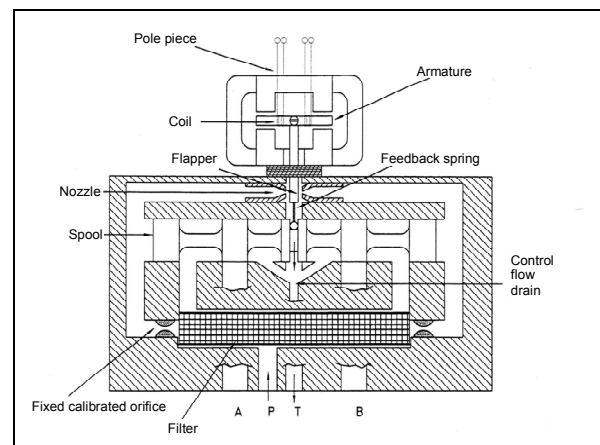

Figure 2. Schematic of the flapper-nozzle servo-valve.

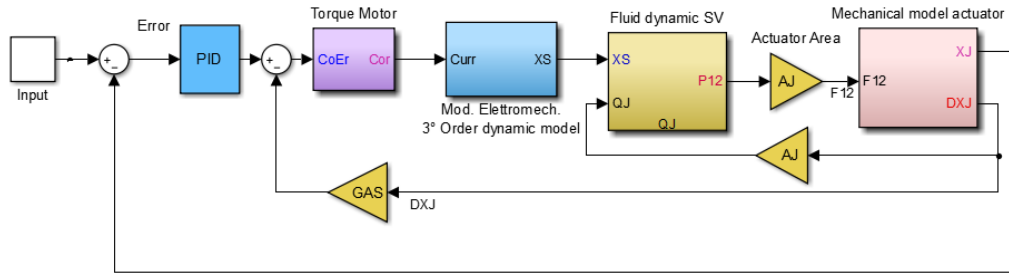

Figure 3. Simulink block diagram of the considered EHA.

In order to develop the abovementioned research, a typical aircraft primary command EHA has been modelled (according to considerations previously reported and widely explained in [11, 20]) and subsequently, implemented in MATLAB Simulink® simulation framework (see Fig. 3); in particular, this numerical model takes into account several details that contribute to the deterioration of the actuation chain, like, in particular, the effect of the clogging of the first stage filter of the servo-valve and the rising progressive loss gain on the torque motor. In addition, it is also able to simulate the effect of disturbing noises provoked by external electro-magnetic sources that interfere with the command input signal from the control module to the valve. According to Fig. 3, the proposed EHA Simulink model is made up of several parts:

- The Input block, used to define the time history of the input (reference position in close-loop test and command to valve in open-loop test).
- The PID block, simulating the behavior of the servomechanism controller.
- The Torque Motor model calculates the mechanical torque acting on the SV first stage.
- The third order dynamic model that reproduces the dynamic response of the flapper-nozzle valve.
- The fluid-dynamic SV block, which for a given spool position and flow rate returns the amount of differential pressure to the chambers of the actuator, using the linearized theory [21].
- The second order block simulating the dynamic response of the linear actuator.

The main aim of the proposed model is to simulate the dynamic response of the EHA for different health conditions (i.e. various combinations of SV first stage filter clogging and torque motor gain loss). Since both progressive failures are relative to the SV, authors developed a new detailed numerical model (according to [7, 11]) able to simulate its dynamic response taking into account the effects of the said failures. Its dynamic fluid model (which calculates the delivery differential pressure regulated by the SV as a function of the spool position and the oil flow disposed of through the valve) has been conceived according to numerical models proposed in [22] and validated by comparing its responses with experimental, analytical and numerical results found in literature [23-27].

The EHA model has been used to simulate the dynamic behavior of the real system in nominal conditions or under several failures level, performing several sets of simulations and, then, developing the following fault modes analysis.

IV. EHA FAILURES AND DEGRADATIONS

Up to now, the degradation of the actuator's performance has been studied by taking into consideration two of the principle fail modes that influence the response of an actuation system. Both cases have been analyzed for a simple 0.01 [m] step command input for the jack position.

The first one regards the filter clogging of the servo-valve first stage. Consequently to the filter clogging, both the first stage pressure and flow rate gains decrease, entailing that the spool results slower in reaching the commanded position; the settling time rises because the maximum differential pressure, available downstream the filter, is reduced. The second fault mode analyzed is the torque motor gain loss. When this phenomenon manifests itself the system responses became slower; in fact, both the jack velocity and the spool position saturation values decrease. The motor is not able to provide a sufficient torque, thus the SV openings are not well controlled. As consequence the differential pressure on the spool is less effective, the dynamic response is more damped, and the overshoot values are lower.

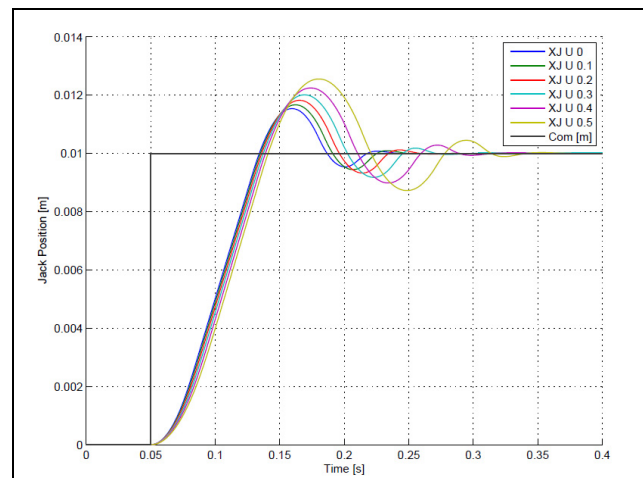

Figure 4. EHA step position response in case of increasing SV first stage filter clogging.

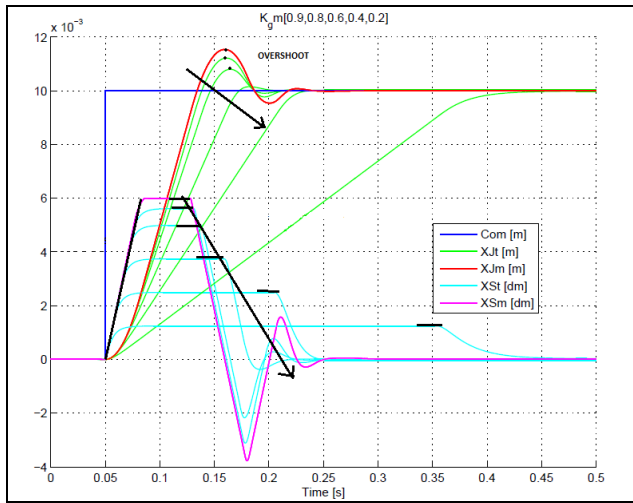

Figure 5. EHA step position response in case of progressive torque motor gain loss.

Referring to Fig. 4 and 5, representing the development of the jack position for increasing values of damage, it should be noted that the two fault modes affect the system response in opposed ways: in case of progressive filter clogging (Fig. 4); the stability margin of the system decreases, while the overshoot rises whereas, in the other case (Fig. 5), the response is always more damped.

V. FEATURES EXTRACTION

On the base of the abovementioned responses analysis, some of the features indicative of system wearing were chosen for the data extraction. They regard the evolution of the jack and the spool position.

For what concerns the jack position, the features are:

- Delay time;
- Rise time;
- Settling time;
- Peak overshoot;
- Time to peak amplitude;

As regards the SV second stage spool position (show, for instance, in Fig. 5), two more features were extracted:

- Maximum spool position in saturation;
- Maximum spool actuation speed;

Figures 7 and 8 put in evidence the evolution of these characteristics. In the case of filter clogging (K_{clogging}) the position reached in saturation by the spool remains constant while its speed decreases as the clogging rises (Fig. 7). On the contrary, for the torque motor gain (K_{GM}) loss the spool speed remains the same while the saturation position decreases (Fig. 8). All these features have been extracted from several simulations and normalized with respect to the correspondent nominal values. The graphs reported in the Fig. 9 and 10 show the normalized features trend with the increasing of the fault percentage. It should be noted that, within a defined failure range (compatible with typical prognostic values), all of them are monotonic: this is an essential characteristic for the correct classification of the input by the Artificial Neural Networks (ANNs).

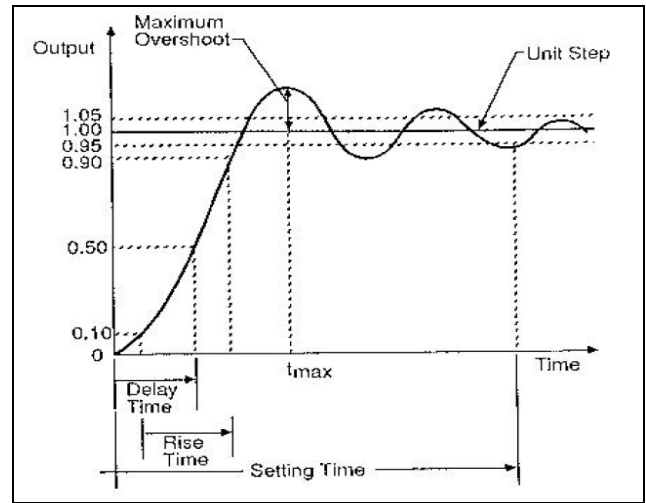

Figure 6. Schematic of the main features related to the linear actuator position.

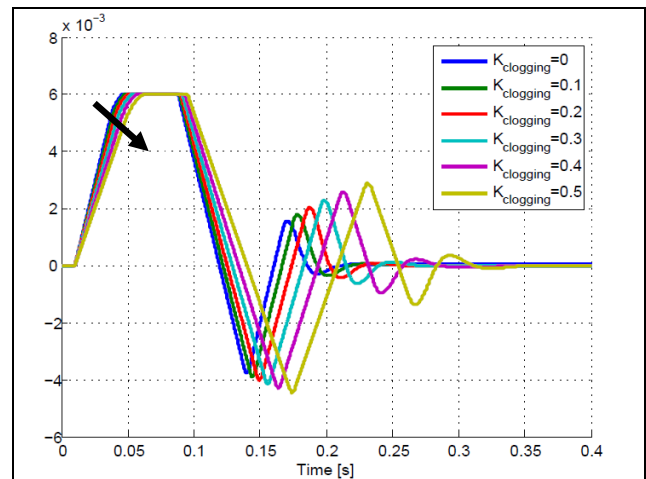

Figure 7. Schematic of the K_{clogging} features related to the SV second stage spool.

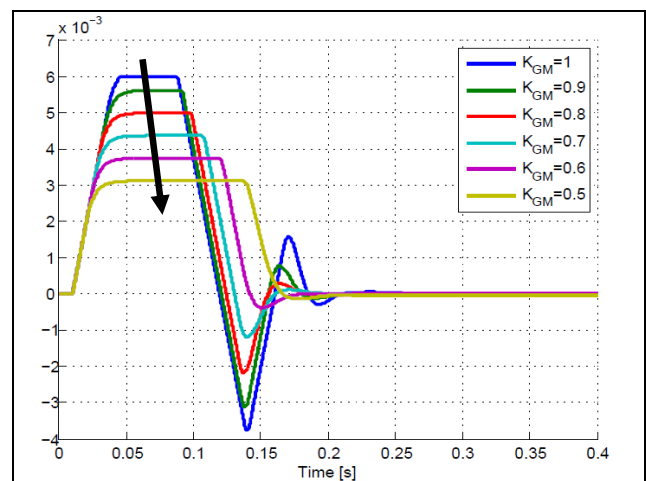

Figure 8. Schematic of the K_{GM} features related to the SV second stage spool.

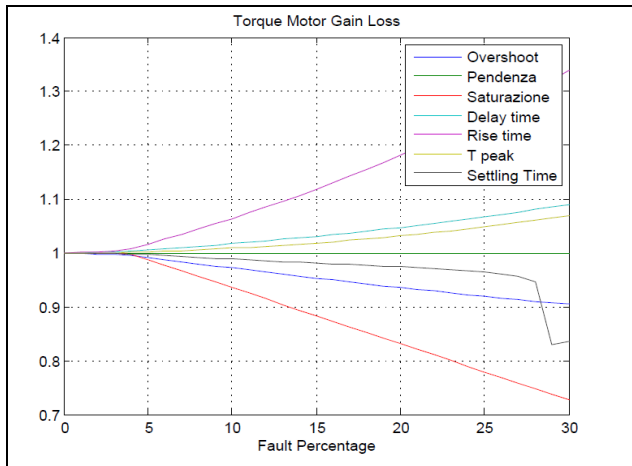

Figure 9. Schematic of the $K_{logging}$ normalized features trend with the increasing of the fault percentage.

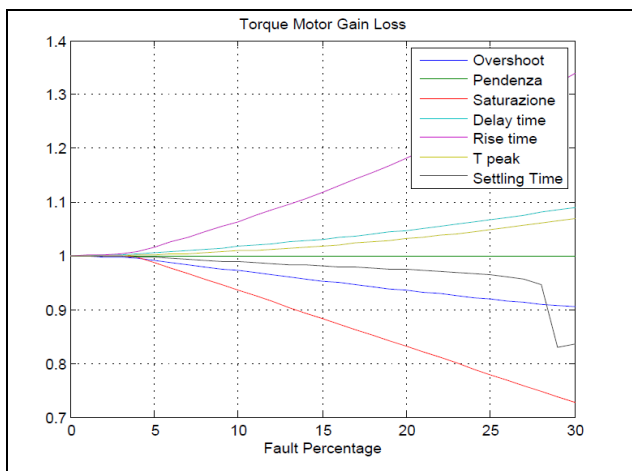

Figure 10. Schematic of the K_{GM} normalized features trend with the increasing of the fault percentage.

VI. ARTIFICIAL NEURAL NETWORKS IMPLEMENTATION

The implementation of neural networks consists of two parts: the learning and identification phase. In the first one, the network is trained by a sample of processed data. In the second phase instead, which is the normal network operating process, the neural network is used to process the input data in accordance with the configuration obtained during the training phase. From a practical point of view, for the training of a neural network, it is necessary to create several training input vectors that correspond to as many target vectors. Each input vector is representative of the conditions in which the model is operating since each row has the associated normalized value of the features extracted from a single simulation. The target vector will have as many lines as the classes within which the network will need to identify the health conditions of the model. Before the learning phase takes place it is necessary to define the number of hidden layers that the neural network will have as also the number of neurons in each layer, the training function and the learning function.

It has been observed that a single layer is often sufficient and that the number of inner neurons has to be set around 20% more than the number of inputs. The chosen training function is the one that updates the weights and bias vector according to Levenberg-Marquardt's optimization [28-29].

It turns out to be the fastest algorithm although it requires more memory than others. Another function that must be defined is the transfer function which is the one that elaborates the data between the neuron's layers. Among the various possibilities, the hyperbolic tangent function has been chosen because it is the one that provided the best results.

VII. ANN PROGNOSTIC SYSTEM INTEGRATION

Seven neural networks were trained and integrated into a single system represented by the scheme shown in Fig. 9.

The proposed FDI prognostic algorithm is composed of two main subsystems, which can provide two different types of classifications: the one leading to the NN1 neural network is able to calculate the level of damage by classification, whereas the other (leading to the NN7 neural network) directly evaluates the magnitude of the progressive faults.

Starting from the first branch of the proposed FDI algorithm (Fig. 11), the NN1 artificial neural network can distinguish whether the model is affected by one or two faults simultaneously. In the first case, it directs the input vector to the NN2 that will identify the failure and, then, the NN3 or NN4 neural networks, depending on the NN2 results, will determine the level of damage.

If the NN1 network recognizes a case of combined failure then the input vector is directed to the NN5 and NN6 networks that will assign the damage levels for each failure.

The FDI algorithm is able to identify four failure levels:

- Level 0: which is a non-critical situation since the damage percentage is estimated between zero and 5%;
- Level 1: a level of low damage, its percentage is estimated between 5% and 10%;
- Level 2: an intermediate level, the percentage is estimated between 10% and 15%;
- Level 3: high level of damage, the fault exceeds 15% of its maximum value;

In any case, the input vector is also supplied to the NN7 network that is able to process both the fail conditions and to provide directly an esteem of these progressive faults. Its results can be cross-checked with those provided by the other networks, in order to get a double check, and in so doing, a more detailed and robust information about the system health. The general structure of the neural networks that provide a simple classification of the damage level (i.e. NN1 - NN6) is shown in Fig. 12. All of them have a single hidden layer, differing one from the other only for the number of neurons. The structure of neural networks that directly estimates the magnitude of the said failures by providing a percentage of the damage is a little more complex (Fig. 13). Comparing it with Fig. 12 it can be noticed one more hidden layer and a supplementary direct feed-forward link among the inner and the outer layer.

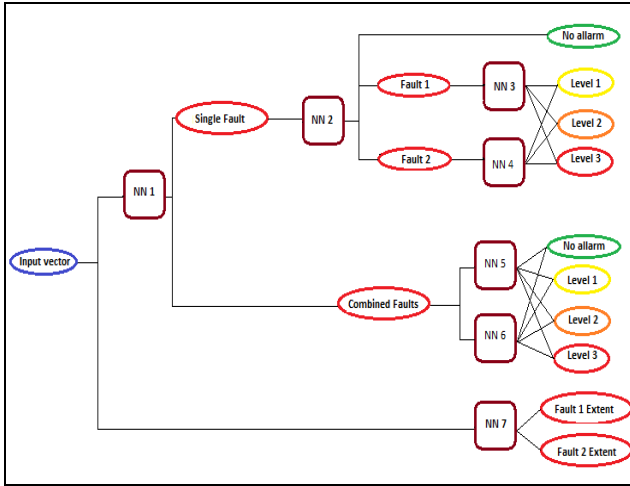

Figure 11. Proposed FDI prognostic algorithm.

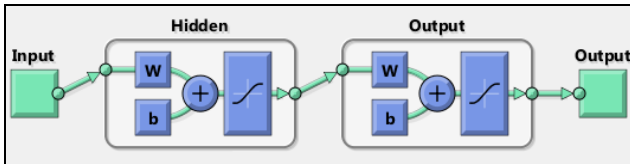

Figure 12. General structure of the ANNs estimating the damage level.

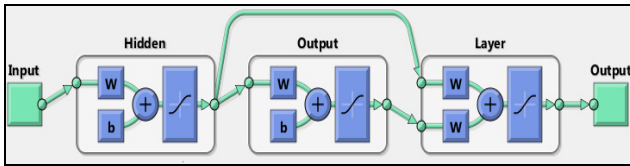

Figure 13. General structure of the enhanced ANN able to perform a direct FDI analysis estimating the damages magnitude.

VIII. FDI TESTING

In order to verify the robustness of the proposed FDI prognostic algorithm, a series of tests were implemented. The first of these regards the single faults, the second treats combined faults and the third considers both cases studies when the model is also affected by a certain amount of noise.

The values of the progressive faults used to test the behavior of the proposed FDI algorithm have been arbitrarily chosen so as to cover all possible fault conditions (both single and combined ones) related to the prognostic application field (i.e. the range within which the prognostic algorithm must be able to range to correctly detect and evaluate the aforesaid failures). Tables I and II show the results obtained in case of single and combined faults. The first two columns represent the percentage of damage actually used for the testing simulations, the following two columns reports the corresponding fault levels detected by the NN1-NN6 neural networks, and the last two columns show the damages estimation performed by the NN7 neural network. As can be seen from the results shown in Table I and II, the proposed algorithm is capable of correctly identifying the various fault conditions by providing a satisfactory level of accuracy in estimation. In order to evaluate its robustness, the proposed FDI algorithm has been tested in condition of electrical noise affecting the feedback signal lines: these tests have been performed with the same percentage of fault level previously used but the signals provided by the jack and spool position sensors have been disturbed by adding to the above signals a white electrical noise. The results of these tests are shown in Table III. It should be noted that results highlighted with red are those with an absolute error exceeding 1%. The NN7 neural network in this case appears to be affected by noise level to the extent that all the given values deviates to the actual ones. In most cases, however, the absolute error with respect to the real fault values does not exceed 0.05%. The only two cases that deviate significantly from this trend are those highlighted in red. In the first case, the network classifies a gain loss of about 4,428% instead of the 2% real, whereas in the second case, the variation is even more pronounced: the network classifies a gain loss of about 5,005% against a 2% real. However, it is important to note that NN5 and NN6, even under these conditions, carry out their task without errors; in fact, even in the worst case, the gain loss identified by NN7 network is such as that it could be classified as a fault level 1, but NN5 and NN6 returns the correct result classifying it as a level 0. However, the miscalculations made by the NN7 neural network in case of noise are not sufficient to compromise the operation of the prognostic method, especially considering the improbable high level of noise under which it was tested.

TABLE I. FDI RESULTS IN CASE OF SINGLE FAULT CONDITIONS

Filter Clogging %	Gain Loss extent	Fault extent level		Fault extent value	
		Filter Clogging	Gain Loss	Filter Clogging	Gain Loss
4%	0%	No allarm	-	3,998%	0%
7%	0%	Level 1	-	7%	0%
12%	0%	Level 2	-	11,999%	0%
17%	0%	Level 3	-	17,000%	0%
0%	2%	-	No allarm	0%	2,054%
0%	7%	-	Level 1	0%	6,987%
0%	14%	-	Level 2	0%	14,005%
0%	21%	-	Level 3	0%	20,995%

TABLE II. FDI RESULTS IN CASE OF COMBINED FAULT CONDITIONS

Filter Clogging %	Gain Loss extent	Fault extent level		Fault extent value	
		Filter Clogging	Gain Loss	Filter Clogging	Gain Loss
4%	2%	No allarm	No allarm	4%	2%
4%	7%	No allarm	Level 1	4%	6,998%
4%	14%	No allarm	Level 2	3,996%	14%
4%	21%	No allarm	Level 3	3,998%	21%
7%	2%	Level 1	No allarm	7%	2%
7%	7%	Level 1	Level 1	6,998%	7%
7%	14%	Level 1	Level 2	7%	14%
7%	21%	Level 1	Level 3	7%	21%
12%	2%	Level 2	No allarm	11,998%	2,01%
12%	7%	Level 2	Level 1	12%	6,999%
12%	14%	Level 2	Level 2	12%	13,995%
12%	21%	Level 2	Level 3	11,999%	21%
17%	2%	Level 3	No allarm	16,997%	2%
17%	7%	Level 3	Level 1	17%	6,999%
17%	14%	Level 3	Level 2	16,999%	13,99%
17%	21%	Level 3	Level 3	16,999%	21%

TABLE III. FDI RESULTS IN CASE OF COMBINED FAULT CONDITIONS AND ELECTRICAL NOISE

Filter Clogging %	Gain Loss extent	Fault extent level		Fault extent value	
		Filter Clogging	Gain Loss	Filter Clogging	Gain Loss
4%	2%	Livello 0	Livello 0	3,99%	2,666%
4%	7%	Livello 0	Level 1	3,781%	8,098%
4%	14%	Livello 0	Level 2	3,963%	14%
4%	21%	Livello 0	Level 3	3,874%	20,933%
7%	2%	Level 1	Livello 0	6,976%	3,193%
7%	7%	Level 1	Level 1	6,772%	8,016%
7%	14%	Level 1	Level 2	6,975%	14,086%
7%	21%	Level 1	Level 3	6,844%	20,928%
12%	2%	Level 2	Livello 0	0,11891	4,482%
12%	7%	Level 2	Level 1	11,801%	7,812%
12%	14%	Level 2	Level 2	11,987%	14,105%
12%	21%	Level 2	Level 3	11,788%	20,915%
17%	0,02	Level 3	Livello 0	0,16809	5,004%
17%	7%	Level 3	Level 1	16,825%	7,629%
17%	14%	Level 3	Level 2	16,980%	14,17%
17%	21%	Level 3	Level 3	16,757%	20,912%

IX. CONCLUSIONS AND FUTURE PERSPECTIVES

In conclusion, it can be stated that the proposed prognostic approach is able to provide a reliable and sufficiently accurate estimate of the analyzed damage and that the redundancy of classifications gives the system some degree of robustness. Additionally, once integrated, the system was able to process incoming information in less than a second which makes this method convenient compared to other approaches used in the prognostic field such as genetic algorithms that generally require much larger processing time, often tens of minutes.

Given the encouraging results obtained, it would be advisable to further test the robustness of this algorithm in presence of other types of electrical disturbance or taking into account any disturbances due to signal digitalization (i.e. disturbances and loss of data accuracy resulting from the ADC). Finally, it is possible to generalize the network system by extracting other significant inputs from model responses (fault precursors) and implementing other networks capable of classifying additional failures.

ACKNOWLEDGMENT

In conclusion, the authors wish to extend a heartfelt thanks to Professor Lorenzo Borello for his essential support in the ideation, definition and development of this work.

REFERENCES

- [1] T. J. Viersma, "Analysis synthesis and design of hydraulic servo systems and pipelines," Elsevier, Delft, 1980.
- [2] P. Dransfield, *Hydraulic control systems. Design and analysis of their dynamics*, Springer Verlag, Berlin, 1981.
- [3] G. Vachtsevanos, F. Lewis, M. Roemer, A. Hess, and B. Wu, *Intelligent fault diagnosis and prognosis for engineering systems*, Wiley, 2006, ISBN: 978-0-471-72999-0.
- [4] K. Goebel, M. Daigle, A. Saxena, S. Sankararaman, I. Roychoudhury, *Prognostics: the science of making predictions*, CreateSpace Independent Publishing Platform, 2017. ISBN: 9781539074830.
- [5] C. S. Byington, W. Watson, D. Edwards, and P. Stoelting, "A model-based approach to prognostics and health management for flight control actuators," *IEEE Aerospace Conference Proc.*, 2014, USA.
- [6] W. F. Bonnice, W. Baker, "Intelligent fault diagnosis and failure management of flight control actuation systems," *NASA-CR-177481*, 1988.
- [7] L. Borello, M. D. L. Dalla Vedova, G. Jacazio, and M. Sorli, "A prognostic model for electrohydraulic servovalves," *Proceedings of the Annual Conference of the Prognostics and Health Management Society*, 2009, San Diego.
- [8] M. Alamyral, S. M. Gadoue, and B. Zahawi, "Detection of induction machine winding faults using genetic algorithm," *Diagnostics for Electric Machines, Power Electronics and Drives 9th IEEE Int. Symposium*, Valencia, Spain, 2013, pp. 157-161.
- [9] A. Raie, and V. Rashtchi, "Using a genetic algorithm for detection and magnitude determination of turn faults in an induction motor," *Electrical Engineering*, vol. 84, n. 5, 2002, pp. 275-279.
- [10] M. D. L. Dalla Vedova, A. Germanà, and P. Maggiore, "Proposal of a new simulated annealing model-based fault identification technique applied to flight control EM actuators," *Risk, Reliability and Safety: Innovating Theory and Practice: Proceedings of ESREL 2016*, pp. 313-321.
- [11] P. Maggiore, M. D. L. Dalla Vedova, and L. Pace, "Proposal of prognostic parametric method applied to an electrohydraulic servomechanism affected by multiple failures," *WSEAS Transactions on Environment and Development*, vol. 10, 2014, pp. 478-490.
- [12] D. Belmonte, M. D. L. Dalla Vedova, and P. Maggiore, "Electromechanical servomechanisms affected by motor static eccentricity: proposal of fault evaluation algorithm based on spectral analysis techniques," *Safety and Reliability of Complex Engineered Systems - Proceedings of the 25th European Safety and Reliability Conference, ESREL 2015*, CRC Press, September 2015.
- [13] M. D. L. Dalla Vedova, P. Maggiore, L. Pace, and A. Desando, "Evaluation of the correlation coefficient as a prognostic indicator for electromechanical servomechanism failures," *International Journal of Prognostics and Health Management*, vol. 6, n. 1, 2015.
- [14] M. Battipede, M. D. L. Dalla Vedova, P. Maggiore, and S. Romeo, "Model based analysis of precursors of electromechanical servomechanisms failures using an artificial neural network," *AIAA Modeling and Simulation Technologies Conference*, 2015.
- [15] M. D. L. Dalla Vedova, D. De Fano, and P. Maggiore, "Neural network design for incipient failure detection on aircraft em actuator," *International Journal of Mechanics and Control (JoMaC)*, vol. 17, n. 1, June 2016, pp. 77-83. ISSN: 1590-8844.
- [16] I. Moir, and A. Seabridge, *Aircraft Systems: Mechanical, Electrical and Avionics Subsystems Integration*, 3rd ed., Wiley, April 2008. ISBN: 978-0-470-05996-8.
- [17] D. Karnopp, "Computer simulation of stick-slip friction in mechanical dynamic systems," *Journal of Dynamic Systems, Measurement, and Control*, vol. 107, 1985, pp. 100-103.
- [18] L. Borello, and M. D. L. Dalla Vedova, "A dry friction model and robust computational algorithm for reversible or irreversible motion transmission," *International Journal of Mechanics and Control (JoMaC)*, vol. 13, n. 2, December 2012, pp. 37-48, ISSN: 1590-8844.
- [19] L. Borello, G. Villero, and M. D. L. Dalla Vedova, "New asymmetry monitoring techniques," *Aerospace Science and Technology*, vol. 13, n. 8, December 2009, pp. 475-497. doi:10.1016/j.ast.2009.07.006.
- [20] G. Jacazio, and L. Borello, "A non-linear model of an electro hydraulic servo system with axial piston hydraulic motor," *7th International Fluid Power Symposium*, 1986, Bath, England.
- [21] G. Jacazio, and L. Borello, "Mathematical models of electrohydraulic servovalves for fly-by-wire flight control systems, 6th Int. Congress on Mathematical Modelling, 1987, St. Louis.
- [22] L. Borello, M. D. L. Dalla Vedova, and P. Alimhillaj, "Proposal of Innovative Fluid Dynamic Nonlinear Servovalve Synthetic Models," *International Journal of Mechanics and Control (JoMaC)*, vol. 14, n. 2, December 2013, pp. 39-49. ISSN: 1590-8844.
- [23] H. E. Merritt, *Hydraulic control systems*, New York: Wiley, 1967.
- [24] X. Dong, and H. Ueno, "Flows and flow characteristics of spool valve," *Proceedings of Forth JHPS International Symposium on fluid power*. Tokyo: S. Yokota, 1999, pp. 51-56.
- [25] G. Di Rito, "Experiments and CFD simulations for the characterisation of the orifice flow in a four-way servovalve," *International Journal of Fluid Power*, vol. 8, no. 2, FPNI/TuTech, 2007.
- [26] X. Pan, G. Wang, and Z. Lu, "Flow field simulation and a flow model of servo-valve spool valve orifice," *Energy Conversion and Management*, n.52, Elsevier, 2011, pp. 3249-3256.
- [27] L. Pace, M. Ferro, F. Fraternali, M. D. L. Dalla Vedova, A. Caimano, and P. Maggiore, "Comparative analysis of a hydraulic servo-valve," *International Journal of Fluid Power*, vol. 14, 2013, pp. 53-62, ISSN: 1439-9776.
- [28] D. Marquardt, "An Algorithm for Least-Squares Estimation of Nonlinear Parameters," *SIAM Journal on Applied Mathematics*, vol. 11, no. 2, June 1963, pp. 431-441.
- [29] M. T. Hagan, and M. Menhaj, "Training feed-forward networks with the Marquardt algorithm," *IEEE Transactions on Neural Networks*, vol. 5, n. 6, 1999, pp. 989-993, 1994.

AUTHORS' BACKGROUND

Your Name	Title*	Research Field	Personal website
Matteo Davide Lorenzo DALLA VEDOVA	Assistant professor	Aeronautical Systems Engineering, Design, Analysis and Numerical Simulation of On-Board Systems, Study of Secondary Flight Control Systems and Conception of Related Monitoring Strategies, Development of Prognostic Algorithms for Aerospace Servomechanism, Study of Innovative Primary Flight Control Architecture	http://www.dimeas.polito.it/en/personale/scheda/(nomi nativo)/matteo.dallavedova
Paolo MAGGIORE	Associate professor	Energy management and hydrogen fuel cells power units, Safety and Reliability of Mechatronic Systems, System Engineering and Multi-Disciplinary Design Optimization, Design and Control of UAVs, Prognostic and Health Monitoring	http://www.dimeas.polito.it/en/personale/scheda/(nomi nativo)/paolo.maggiore
Gianluca CERQUA	Master student	Development of Prognostic Algorithms for Aerospace Servomechanism	

*This form helps us to understand your paper better, the form itself will not be published.

*Title can be chosen from: master student, Phd candidate, assistant professor, lecture, senior lecture, associate professor, full professor