

Solutions based on thermoelectric refrigerators in humanitarian contexts

Original

Solutions based on thermoelectric refrigerators in humanitarian contexts / Enescu, Diana; Ciocia, Alessandro; Mazza, Andrea; Russo, Angela. - In: SUSTAINABLE ENERGY TECHNOLOGIES AND ASSESSMENTS. - ISSN 2213-1388. - 22:(2017), pp. 134-149. [10.1016/j.seta.2017.02.016]

Availability:

This version is available at: 11583/2702200 since: 2020-01-27T23:51:16Z

Publisher:

Elsevier Ltd

Published

DOI:10.1016/j.seta.2017.02.016

Terms of use:

This article is made available under terms and conditions as specified in the corresponding bibliographic description in the repository

Publisher copyright

(Article begins on next page)

SOLUTIONS BASED ON THERMOELECTRIC REFRIGERATORS IN HUMANITARIAN CONTEXTS

Diana Enescu
Electronics, Telecommunications and Energy Department
Universitatea Valahia Târgoviște
Targoviste, Romania
diana.enescu@valahia.ro

Alessandro Ciocia, Andrea Mazza, Angela Russo*
Energy Department
Politecnico di Torino
Corso Duca degli Abruzzi 24, Torino, Italy
alessandro.ciocia@polito.it; andrea.mazza@polito.it;
angela.russo@polito.it

* corresponding author

Abstract

In humanitarian and refugees contexts, to give an adequate quality of life to people living in emergency conditions, energy supply is very important to face with the main problems concerning food cooking and food preservation. The traditional vapour compression refrigerators have relatively high efficiency, but they may have a critical impact on the electric supply system. For this reason, new solutions with thermoelectric refrigerators are emerging; in spite of lower efficiency, they may be more compatible with proper operation of the electrical grid. Furthermore, thermoelectric refrigerators can be used in any position, do not depend on a circulating refrigerant fluid, and are not sensitive to mechanical vibrations. These properties are useful for temporary installations that have to be moved from time to time – typical conditions for some humanitarian camps. This paper addresses the electrical characteristics of a thermoelectric refrigerator connected to the power grid in a microgrid-like installation. A sustainable solution in which the thermoelectric refrigerator is connected to a microgrid powered by a photovoltaic plant and equipped with an electric storage system designed and simulated.

Keywords: energy efficiency, food preservation, microgrid, thermoelectric refrigerator.

1. Introduction

At worldwide level, it is considered that 15% of the total electrical energy consumption is used for various types of refrigeration purposes [1]. Furthermore, refrigeration is used for 40% of all kinds of food [2].

Refrigeration and freezing processes are based on the heat removal from the food in order to maintain a certain temperature in the food storage compartment. The useful temperatures are included in the range of (0°C, 10°C) for refrigeration and below -10°C for freezing [3]. The refrigeration process makes the development and reproduction of microorganisms slower, as well as the enzymes influence which provokes food rotteness. In this way the refrigeration is helpful for food preservation. The freezing process modifies the physical properties of a substance by transforming water into ice during the heat removal. The freezing process under -30°C slows the production and growth of microorganisms, the action of enzymes for decomposing the food, rising the storage time [4]–[7].

This paper focuses on the potential of exploiting thermoelectric cooling as an interesting option to be applied in a refrigeration system for food preservation, thereby exploiting its use to provide the cooling effect. In this respect, a thermoelectric cooler (TEC) is a very flexible element that can be introduced in an electrical demand management system. Its flexibility, whose main aspects are recalled below, is a value added with respect to conventional vapour compression refrigerators.

The main advantages of the thermoelectric technology compared with other solutions are:

- the possibility of constructing movable systems with small weight;

- limited maintenance needs and long duration of use because of the absence of moving parts;
- the absence of toxic or flammable refrigerants;
- the possible direct current (DC) supply, opening the usage of thermoelectric equipment in systems powered in DC, e.g., connected to photovoltaic (PV) systems or batteries;
- the possible exploitation for heating and cooling.

Some equipment using thermoelectric technology for food are domestic refrigerators, refrigerators/freezers, hotel room (mini-bar) refrigerators (preferred for their silent operation), refrigerators for mobile homes, trucks, recreational vehicles and cars, food service refrigerators for airborne application, and portable picnic coolers [8].

In addition to thermoelectric refrigeration, some new/alternative refrigeration technologies like trigeneration, air cycle refrigeration, sorption refrigeration [9], Stirling cycle units, thermoacoustic and magnetic refrigeration applied to food refrigeration in order to reduce energy consumption have been presented in [8]–[10].

The present trend towards the use of green energy raises the attention on the possibility of supplying the thermoelectric refrigerator (TER) through energy produced from renewable sources. The intermittency and uncertainty of the renewable energy production requires the presence of storage to compensate for the fluctuations and the absence of power generation in given time periods. The refrigerators powered by renewable sources may work in *stand-alone* or *off-grid* configuration, namely, without connection to the electrical grid. On the electrical side, the storage consists of a battery that ensures the provision of electrical supply when the PV modules are not able to cover the demand of electricity. On the thermal side, thermal storage realized with ice may be connected with the refrigerator. This solution is useful in situations in which it is possible to guarantee to maintain the ice in an appropriate location [3].

The technologies used to obtain refrigeration from solar energy are:

- *solar thermal refrigeration* (thermo-mechanical refrigeration and sorption refrigeration) [11]–[13];
- *solar electric refrigeration* (vapour compression refrigeration, thermoelectric refrigeration, Stirling refrigeration) [12];
- *new emerging technologies* (electrochemical refrigeration and ejector refrigeration) [11].

Solar electric refrigeration uses solar energy to power a refrigerator for cooling the refrigeration surface [14]. Two types of solar-driven refrigeration systems are solar PV/battery refrigerator system and solar PV/phase change materials (PCMs) refrigerator system. These systems have also different modes of thermal energy storage. A solar PV/battery refrigeration system is composed of the PV panels, the battery storage, the control systems (for PV maximum power point tracking and battery charge control), and the refrigeration unit [15]. For PV/PCMs thermoelectric refrigeration [16], the hot side of the TEC is connected to the PV panel, and the cold side of the TEC is connected to the PCMs substituting the battery storage [15]. The utilization of PCMs in domestic refrigerators is a new solution with the potential to increase the unit performance [17].

There are two cases to connect a refrigerator to the PV panel in an off-grid system:

- The refrigerator *directly powered* by the PV panel: the main components are the PV panel, the battery bank, the battery charge controller, and the refrigerator. A DC compressor is used to avoid inverters. The DC compressors are designed to work in a great voltage range being an advantage for solar refrigeration [18]. In this case, an inverter is not necessary, since DC supply is used for the refrigerator. All the connection between the PV panels and the compressor are in DC.
- The refrigerator *indirectly powered* by the PV panel: the main components are the PV panel, the battery bank, the inverter for AC grid connection, and the AC-supplied refrigerator [19], [20].

Ekren and Celik (2013) [21] experimentally investigated the performance of solar powered DC and AC refrigeration units. The results showed that DC refrigerator powered by PV is more efficient than AC refrigerator powered by PV. Opoku et al. (2016) [22] also carried out a comparative techno-economic evaluation between a solar powered DC refrigerator and a solar powered AC refrigerator.

They recommend that it is more economical and efficient to use a solar powered DC refrigerator than the other one.

Various researches concerning the performance of PV powered refrigeration systems were extensively studied in [23] – [30].

The progress of local energy systems (i.e., remote microgrids) is considered as a solution for the electrification of small remote communities. In the condition of climate change reduction and sustainable energy progress, the adoption of microgrids supplied by renewable energies in various different environments represents a good solution [31], [32]. The results of various studies on the electrification of remote areas have been reported in recent contributions [33] – [36]. These results may be useful to deal with a particular type of local energy system – the temporary camps used in the humanitarian context [37]. These camps have been seen as remarkable benchmarks for developing solutions based on renewable energy technologies [38]. In this case, there are particular conditions that require specific installations and operation modes of the equipment connected to the local system. For example, some camps could need to be moved in time from one location to another. The connections have to be robust enough to withstand their successive plug on and plug off, and the equipment has to be operational also in moving conditions.

In general applications to remote areas, social aspects such as thefts and improper usage of the electrical supply of the refrigerator to serve extra loads (TV set, lights, food and drinks) may produce misoperation of the refrigeration system [39]. In refugee camps the situation is mitigated by the central management and control of the areas and technological systems.

The equipment such as vapour compression refrigerators may suffer from being moved, because of their sensitivity to the position of use and to mechanical vibrations. In some cases, the refrigerant used could be harmful in case of failures because of its toxicity, even though non-toxic working fluids are available (e.g., natural refrigerants such as CO₂ and hydrocarbons) [40], [9]. The current trends towards replacement of the chlorofluorocarbons (CFCs) consider preferred solutions with low Global Warming Potential (GWP) using these non-toxic natural refrigerants, as well as new generation synthetic refrigerants like HydroFluoro-Olefins (HFOs). However, CO₂ is used at pressures much higher than traditional refrigerants, while hydrocarbons and HFOs are flammable or mildly flammable [41]. These aspects suggest the use of thermoelectric cooling as an alternative refrigeration technology, because of its positive characteristics indicated above and its eco-friendly application.

In this paper, the experimental investigation of a TER is carried out, in order to highlight its technical characteristics in different operational conditions and the importance of its use in a microgrid framework. The TER operation is investigated by considering the power drawn from the grid at different external conditions and by varying the quantity of product located inside the internal conservation compartment.

The following sections of this paper are organized as follows. Section 2 describes the theoretical aspects of thermoelectric, vapour compression and absorption refrigeration. Section 3 points out the energy efficiency aspects of the refrigeration technologies considered. Section 4 deals with the characteristics of the microgrids as local distribution systems useful to supply the local system in remote areas by interfacing the equipment with the local generation available. Section 5 presents the setup of the experimental testing of a TER and the results of the experimental activity carried out in different operating conditions. Section 6 shows the results of the numerical analysis of a stand-alone system with a TER, a PV panel and a storage system. The last section contains the conclusions and indicates possible future works.

2. Theoretical aspects of thermoelectric, vapour compression and absorption refrigeration

2.1. Thermoelectric refrigeration

Thermoelectric refrigeration is based on the Peltier effect (electrical energy is converted into thermal energy) in order to create a heat flux between the junctions of two different types of materials. The purpose of thermoelectric refrigeration is to transport heat from one zone to another by the utilization of electrical energy.

A TEC is composed of a one-dimensional pair of thermoelement legs (one leg is a semiconductor of N-type having an excess of electrons, with a negative Seebeck coefficient, and the other leg is a semiconductor of P-type having deficiency of electrons, i.e., excess of holes, with positive Seebeck coefficient) connected at one end by a conducting metal strip to form a junction (Fig. 1). The number of thermoelement legs in a thermoelectric module (TEM), consisting in many TECs, mainly depends on the required cooling capacity and the maximum electric current [42]. The most used materials used for the thermoelement legs are a compound of bismuth and tellurium well known as bismuth telluride (Bi_2Te_3) alloyed with antimony or selenium. The bismuth telluride is helpful for developing of TECs in order to obtain temperatures under ambient temperature without using the vapour-compression refrigeration technology [43].

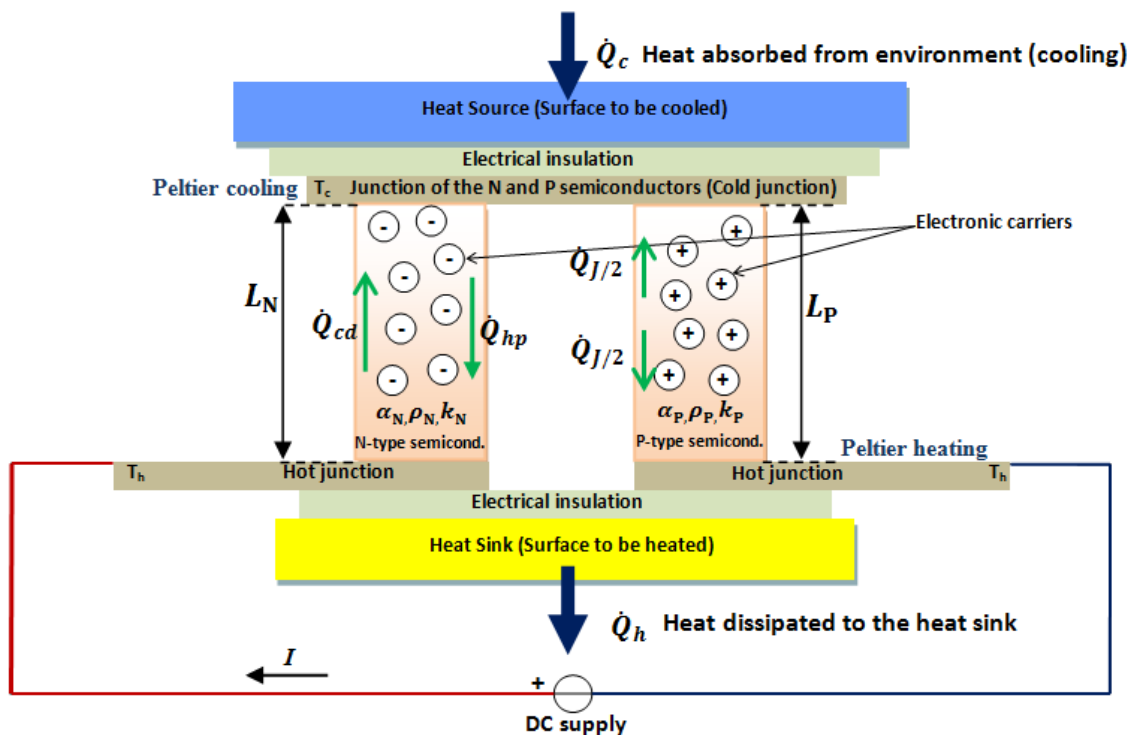

Fig.1. Scheme of a simplified single TEC.

The legs are connected electrically in series but act thermally in parallel. In cooling mode, a DC voltage is applied through the device. This DC power to the TEC makes the electrons move through the semiconductor material, at the junction of the N and P semiconductors (the current flows from N-type to the P-type), and the temperature is reduced to T_c , being followed by absorption of heat flux from the space to be cooled [44]. This happens because electrons move from a low energy level in the P-type semiconductor to a higher energy level in the N-type semiconductor absorbing thermal energy (cold side). This phenomenon produces the heat flow. When the current flows, the cold junction absorbs heat, while the hot lower junction produces heat. In the N-type semiconductor, the electrical current flows in the same sense with the electrons flow, while in the P-type semiconductor, the electrical current flow is contrary to the holes flow [45]–[48]. Therefore, the majority electronic carriers transport the absorbed heat through the thermoelements towards the hot junction of the temperature T_h , then this heat is liberated at the other end of the device, when the electrons return to a low energy level in the P-type semiconductor [49], [9]. Conversely, if the polarity of the DC voltage is reversed, the temperature at the other side is increased. For this reason,

the thermoelectric couple can be used as a basic module either for cooling or for heating purposes [50].

The basic components of a TER [3] are (Fig. 2):

- An insulating compartment having variable thicknesses in function of the cooling capacity (e.g., for a unit with a cooling capacity varying from 5 to 40 l, the thickness varies from 5 to 10 cm, while 3-4 cm may be used in smaller refrigerators up to 5 l of capacity); in this compartment, freezing is not allowed.
- One TEC or TEM consisting of multiple semiconductors connected in series, sandwiched between electrically insulating, and thermally conductive, ceramic substrates.
- One or more heat sinks with and without fins, thermally coupled with a TEC or TEM in order to improve heat dissipation; in some cases the heat sinks are located both at the cold and hot sides of the TEC or TEM [16], [51], [52];
- One or many fans or heat exchangers for facilitating the movement of heated or cooled air. The heat exchange with the surrounding air is particularly needed to avoid operational problems.
- A control unit is used to establish the DC current to be sent to the TEC. The TEC is typically used to cool the insulated compartment; in principle, it is possible to heat the insulated compartment by reversing the direction of the current flow.

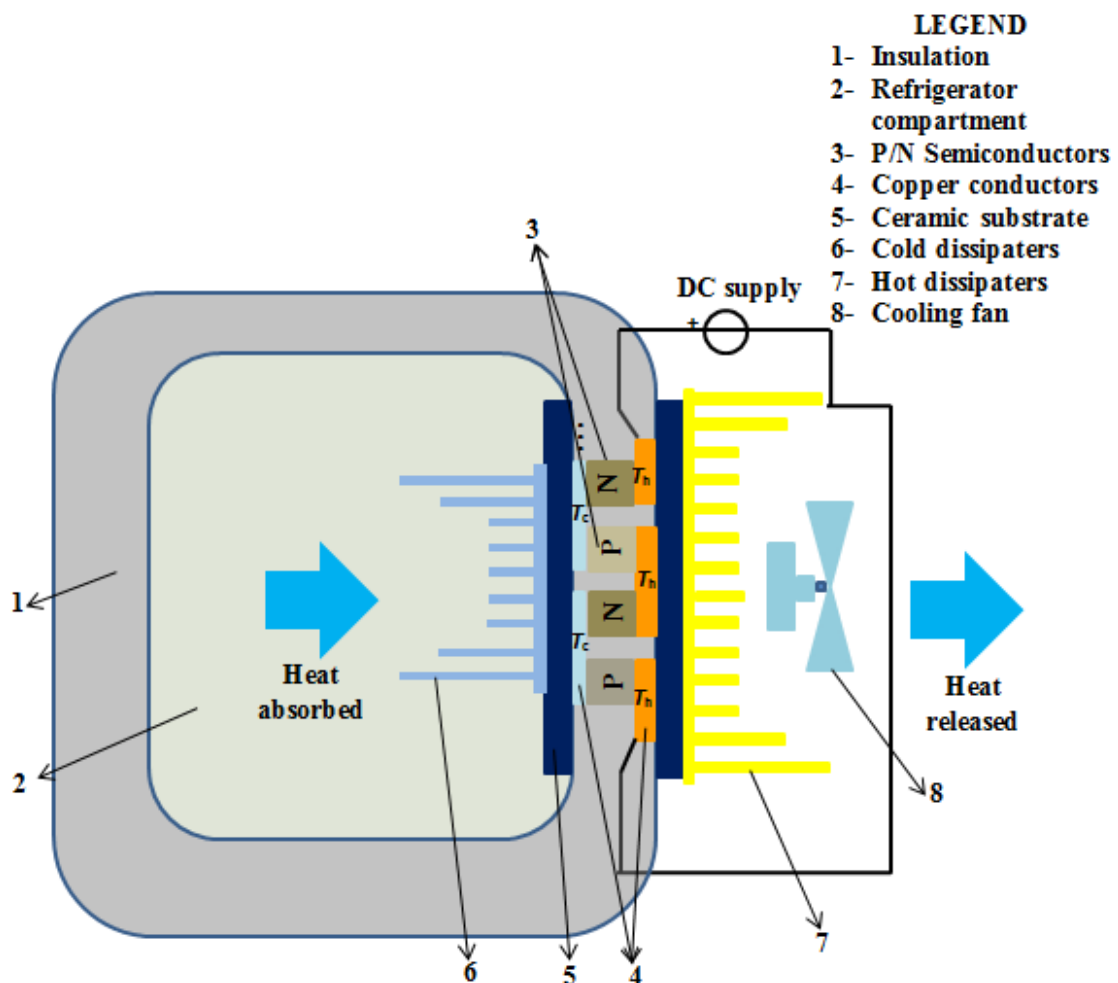

Fig.2. Scheme of a TER.

2.2. Vapour compression refrigeration system

A vapour compression refrigeration (VCR) system is a cyclic unit which operates with a working fluid called refrigerant, absorbing the heat and remove it from the cold environment (i.e., conservation compartment). In this case, the compartment temperature is reduced at a certain limit (Fig. 3a).

Some widely used refrigerants are R134a (which belongs the HFCs group) and R22 (which belongs the HCFCs group), but as alternative new eco-friendly refrigerants having low or null Global Warming Potential (GWP) are introduced [53]-[59].

The basic components of a vapour compression refrigerator [65] are (Fig. 3b):

- A *waterproof thermal insulated compartment* (e.g. polystyrene), having insulation of variable thickness (e.g., the thickness range varies from 3-4 cm in home refrigerators to 10-15 cm in standalone solar refrigerators). It is also necessary the utilization of a drainage system to let the condensation water flowing outside the compartment [3].
- An *evaporator*, where the refrigerant enters in the liquid state and low pressure, absorbs the heat from the conservation compartment which is cooled, and evaporates (being transformed from liquid state to gas state) at constant pressure; in this way, the cooling power is produced [60], [61].
- A *compressor*, where the refrigerant enters as a low temperature, low pressure saturated vapour, and is compressed reversibly and adiabatically; the process is accompanied by the pressure and temperature increment of refrigerant; the solutions for small-size compressors may have the electric motor supplied in AC or in DC [61].
- A *condenser*, where the high pressure hot refrigerant enters and condenses using ambient air temperature to cool it; in this way, the refrigerant loses heat and liquefies (being transformed from vapour state to liquid state) at constant pressure condenser [62], [63].
- An *expansion valve*, where the refrigerant as a high pressure, medium temperature liquid is forced and is expanded irreversibly and adiabatically; the role of the expansion valve is to reduce the refrigerant pressure and make it vaporize; after that, the refrigerant as a low-quality vapour leaves the expansion valve and is sent to the evaporator, restarting the cycle [61], [64];
- A *control device*, useful to regulate and to keep a constant temperature inside the conservation compartment, where the compressor is regulated by a thermostat [3].

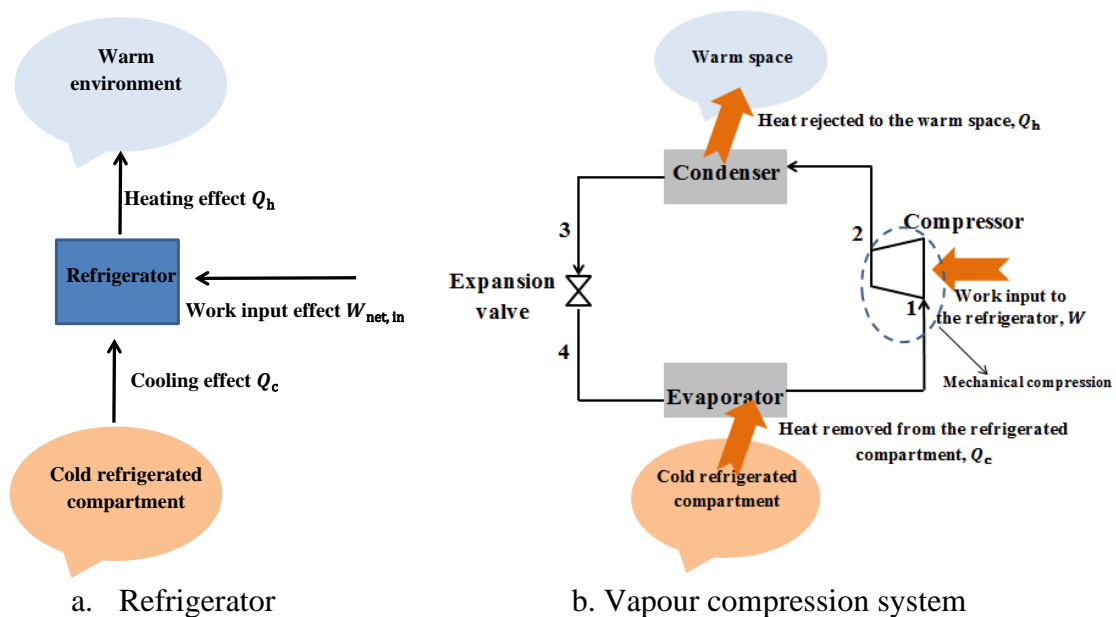

Fig.3. Schematic of refrigerator and vapour compression system.

2.3. Vapour absorption refrigeration system

The vapour absorption refrigeration (VAR) is similar to the VCR. The VAR uses thermal energy at a lower temperature without the need to convert it into mechanical energy as in the VCR. In both VCR and VAR cycles, the heat is removed through the evaporation of a refrigerant at a low pressure and it is rejected through the condensation of the refrigerant at higher pressure [66]. The difference is that, in the VAR, the compressor is replaced with an absorber, a generator and a solution pump. Another difference is that the VCR works at different pressures to determine the refrigerant flow, while VAR works at a constant single pressure because it is not necessary to compress the refrigerant [67]. The system performance depends on the physical and thermodynamic properties of the working fluid. In the VAR, the working fluid is a mixture (refrigerant and absorbent) which has to be chemically stable, non-toxic, and non-explosive [68]. Different working fluids were analysed in the literature [66], [68]-[70]. The most common mixture for working fluid with practical applications are $\text{NH}_3\text{-H}_2\text{O}$ (ammonia as refrigerant and water as absorbent), and $\text{H}_2\text{O-LiBr}$ (water as refrigerant and lithium bromide as absorbent). The $\text{NH}_3\text{-H}_2\text{O}$ working pair is used for refrigeration and $\text{H}_2\text{O-LiBr}$ working pair is used for the cooling of air [71], [72]. These fluids are separated and recombined in the absorption system. The refrigerant is condensed in the condenser and after that is evaporated in the evaporator where the cooling effect is produced.

The basic components of the VAR which uses water as absorbent [66] are (Fig. 4):

- A *generator*, where the solution with the working fluid is heated by the heat transferred through a pipe in which steam or hot water flows; most of the refrigerant vaporizes and is separated by the absorbent; the refrigerant vapour flow goes to the condenser, while the “weak” solution mostly composed of the absorbent is sent to the absorber.

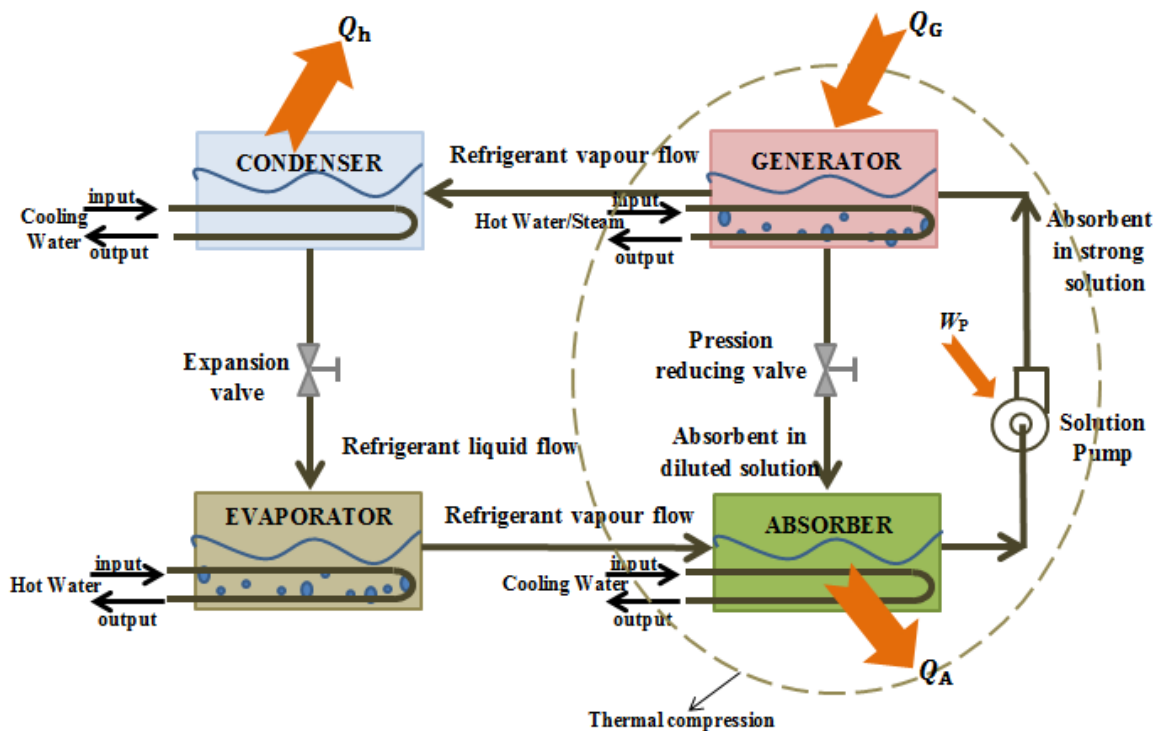

Fig.4. Schematic of absorption refrigeration cycle.

- A *condenser*, where the vaporized refrigerant is condensed on the external surface of cooling water pipes and is sent in liquid form to the expansion valve (the pressure and temperature of refrigerant decreases suddenly passing through the expansion valve).
- An *evaporator*, where the liquid refrigerant is vaporized through the action of the heat exchanged with a pipe with internal hot water circulation, and is then sent to the absorber.

- An *absorber*, in which the vaporized refrigerant is transformed into water and is mixed with the liquid absorbent to form the working fluid solution. The “strong” solution composed of refrigerant and absorber is then pumped at high pressure to the generator.

The VAR is very restricted to large scale applications even if it has many advantages compared with the VCR (e.g., few moving parts, no noise, and environment-friendly working fluids as refrigerants instead of chlorofluorocarbons (CFCs) [73]). In addition, it is used with different types of inputs like solar thermal energy, waste heat, or traditional fuels [3], [74]. In the case of the small scale applications, the VAR is not competitive with the VCR, due to higher complexity [75] and high initial cost [76]. Furthermore, the VAR units have lower efficiency than VCR units [74]. A comprehensive review about these systems has been carried out in [72] and [73]. Even if the VAR technology is suitable for off-grid areas, a comparative experimental analysis in the humanitarian context is not available. Thereby, the following section presents a comparative analysis concerning the performance and energy efficiency of vapour compression and thermoelectric refrigeration technologies used in off-grid areas.

3. Energy efficiency and operation of the refrigeration units

3.1. Performance of the refrigerators

The performance of a refrigerator depends on the cooling capacity or heat removed from the refrigerated compartment and the required work input to the refrigerator [65]. The range of the coefficient of performance (*COP*) values for the vapour compression refrigerators varies from 1.5 to 3.5 depending on size, load conditions and operating temperatures [3].

The *COP* of heat-driven refrigeration machines (sorption and TEC) is usually less than 1.0 for commercial units presently available in the market [77], [78]. The *COP* of a TEC depends on the cooling capacity and the input electrical power. The maximum *COP* of a TEC is used for its sizing [42], [79], [80]. The value of *COP* for a TER is about 20% of the *COP* of a vapour compression refrigeration unit [3]. A disadvantage of TEC is that the *COP* is lower than in case of the vapour compression refrigeration system, leading to a higher power consumption to obtain the same cooling effect [47], [81], [82].

The main advantages of TEC compared to vapour compression refrigeration are that TEC uses electrons as heat carriers and not refrigerants (so there is no circulating fluid), there are no moving parts with the exception of fans (this require little or no maintenance, being ideal for cooling parts that may be sensitive to mechanical vibration), has a low-noise operation, and it is possible to produce either heat or cooling with the same module by changing the direction of the DC current [43], [49], [81],[83]–[86].

For cooling purposes, an interesting property is the TEC ability to reduce the temperature below the ambient temperature. Another advantage is that the degree of cooling may be easily controlled by mean of the current supplied to the thermoelectric elements. This gives a fast dynamic response and a very exact temperature control, with which it is possible to control temperatures inside a +/- 0.1°C range [82].

Besides these advantages, thermoelectric cooling does not use any compressor, absorbers, expansion valves or pumps [52]. A TEC does not use chlorofluorocarbons dangerous to the environment, and for this reason is considered environmentally friendly [87].

One of the characteristics of the thermoelectric device is the way the power taken from the electrical supply point changes during time. Different types of temperature controls have been tested, exploiting the advantage of the TERs to enable accurate control of the temperature. The on/off temperature control is simple and relatively cheap. However, during the off period, the heat stored in the heat exchanger connected to the hot side of the TEC goes back to the refrigerator [88]. Better results may be obtained with alternative controls, e.g., constant input current [89].

For food preservation, an accurate control of the inner temperature for the refrigerator compartment is beneficial. This control is much better assured by TEC compared to the vapour compression refrigeration system. This is explained by the fact that in case of TEC, the supplied voltage to the Peltier module can be modified in order to regulate the cooling power as necessary [51], [90], [91]. Furthermore, in case of the vapour compression refrigeration system, the control of the inner temperature is inaccurate, because the compressor operates with start and stop cycles producing a temperature variation greater than 8°C, which has a negative effect on food preservation [91], [92].

3.2. Examples of controllability of the refrigerators

In order to show the behaviour of the TER without duty cycle, measurements have been carried out during time at fast time resolution (one second). The curve shown in Fig. 5 has been obtained by filling up a TER with small bottles of water (0.5 l each) introduced at ambient temperature. For the curve, the TER presents a quite flat and high consumption (when the refrigerator is filled up) allowing reaching the internal temperature set-point, followed by a decreasing exponential (once the temperature set-point has been almost reached, the energy for maintaining the temperature decreases). In the same figure, the variation of the internal temperature is shown.

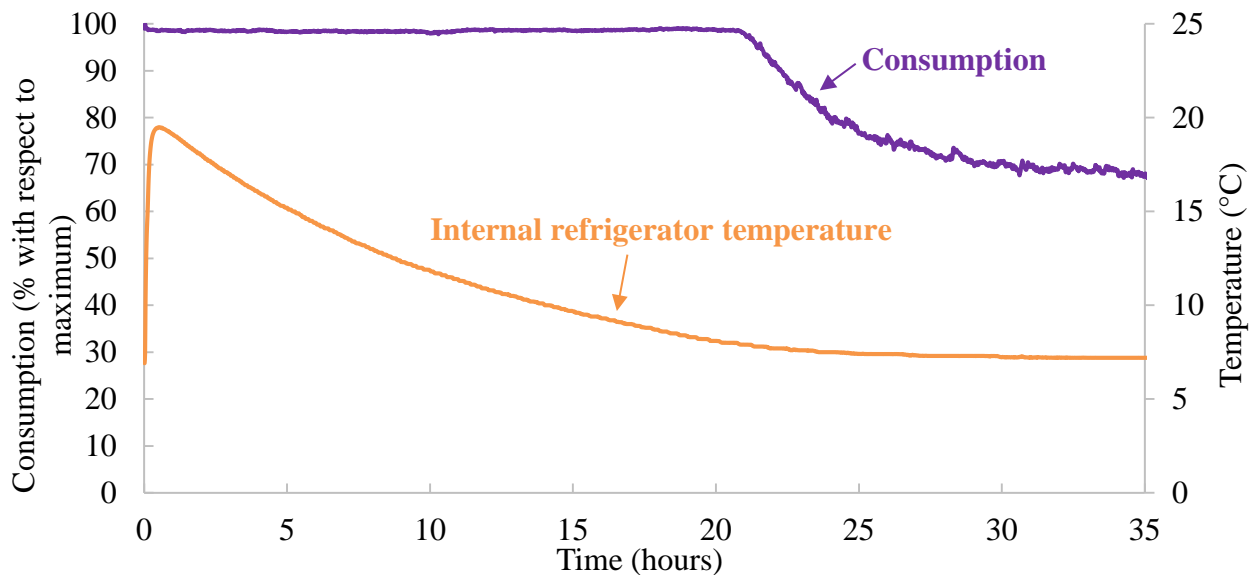

Fig. 5. TER – Evolution in time of active power and internal temperature

For a household vapour compression refrigerator, a typical load profile is shown in Fig. 6. It is composed of successive ON-OFF states, and during the ON state the consumption decreases. This behaviour can be described by a fast decreasing exponential followed by an almost linear decrease.

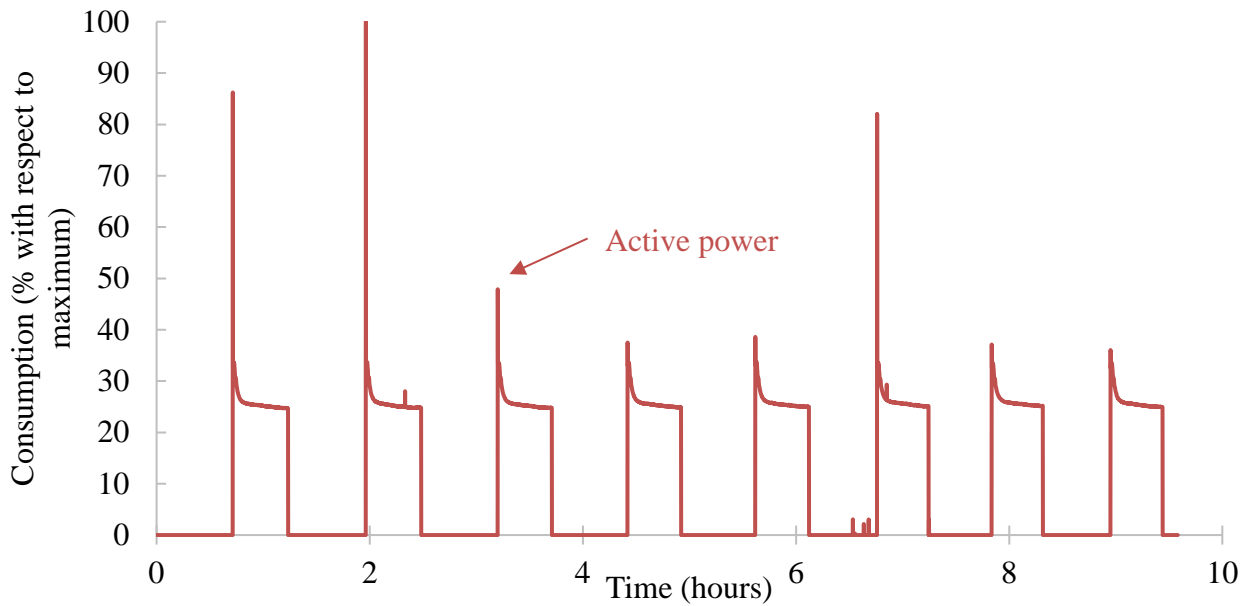

Fig. 6. Vapour compression refrigerator – Evolution in time of the active power.

3.3. Applications of vapour compression and thermoelectric refrigeration units

Let us consider solutions for refugee camps of different types (temporary or permanent), generally located in remote areas. Stand-alone (off-grid) refrigeration units are particularly appropriate in these cases, as they may be used in the absence of an external electrical distribution grid. Solutions with PV-powered refrigeration units are applicable in different ways. The VCR directly powered by PV has a DC compressor, whereas the solution indirectly powered by PV needs a DC/AC converter to connect the AC input of the refrigeration unit. Thermoelectric refrigeration is suitable for outdoor solutions combined with solar cells, where the electricity taken from solar energy is used to supply a TEC.

Table 1 shows the characteristics of a number of refrigeration units with VCR and TER technologies, taken from the literature and based on the available data. The types of units included are both prototypes and commercial units. The units differ in terms of capacity (ranging from small units of a few litres for medicine storage, to larger units of a few hundreds of litres for vaccine, food and drink storage), type of refrigerant, type of voltage input (AC or DC) and input voltage value. Indicative *COP* values are reported, as well as some figures concerning system efficiency (in a number of cases only information on the efficiency of part of the system is available).

Table 1. Characteristics and applications of VCR and TER units

Reference	Technology	Unit type	Capacity (litres)	Description	Voltage	COP	System efficiency (%)	Comments	Applications
Pilatte, 1984 [93]	VCR	Prototype	200	R12 refrigerant DC compressor 60W four 33W _p PV modules 100Ah battery DC motor	12 V (DC)	1.6	max (12.2, 8.10, 5.95,4.62)% for cold source temperatures (10, 0, -10, -20) °C at T _{amb} =32°C	stand-alone, directly powered by the PV	- vaccine storage
Toure and Fassinou, 1999 [94]	VCR	Commercial unit	57	R12 refrigerant T _{cabinet} = 0 ÷ 8°C battery 150Ah -12V P _{nom} =50-70W	12 V (DC)	1.63	--	stand-alone, directly powered by the PV	- vaccine storage and perishable goods in off-grid areas
Zhang et al., 2010 [95]	VCR	Modified commercial AC unit	86	R134a refrigerant DC compressor VRLA battery monocrystalline silicon PV panel with 36 cell units in series	12 V (DC)	--	PV only: 6.5% (average) From solar energy to compressor: 4.5% (average)	stand-alone, directly powered by the PV	- perishable food storage, vaccine, and drug in off-grid areas - electrical appliance in “zero-energy” building
Ekren et al., 2011 [96]	VCR	Commercial unit	50	R134a refrigerant DC compressor, Q _c =76 W T _{cabinet} = 1°C; 15°C lead acid battery 80 Ah 80 W _p	12-24 V (DC)	0.67 (no storage) 0.574 (low load) 0.571 (nominal load) 0.477 (overload)	0.604 0.859 0.810 0.514	stand-alone, directly powered by the PV	- domestic use
Aktacir, 2011 [97]	VCR	Commercial unit	>15	R134a refrigerant 2 PV panels (DC 12V-80W; polycrystalline type) 2 battery units (100 Ah - 12 V)	12-24 V (DC)	--	12.6% (PV only)	stand-alone, directly powered by the PV	- multi-purpose refrigerator system in off-grid areas
Xi et al., 2013 [98]	VCR	Modified commercial AC unit	90	R134a refrigerant DC compressor with 66 W 2 PV panels of 70W two pieces of 12 V batteries in series Power consumption 28.8 W	24 V (DC)	--	--	stand-alone, directly powered by the PV	- multi-purpose refrigerator system
Tina and Grasso, 2014 [99]	VCR	Modified commercial refrigerator	50-89	Medium refrigerator Motor compressor 70 W Mono-crystalline silicon 50 W modules (16 PV cells) two battery banks 12 V, 18 Ah	12-24 V (DC)	--	--	stand-alone, directly powered by the PV	- perishable food storage, vaccine, and drug in off-grid areas

Reference	Technology	Unit type	Capacity (litres)	Description	Voltage	COP	System efficiency (%)	Comments	Applications
Sidney and Lal D, 2016 [100]	VCR	Commercial unit	70	R600a refrigerant DC compressor	10-45 V (DC)	2.10	8.5% (PV only, average)	stand-alone, directly powered by the PV	- multi-purpose refrigerator system
Bansal and Martin, 2000 [74]	VCR	Commercial unit	45	R134a refrigerant $T_{\text{cabinet}} = 5^{\circ}\text{C}$ $P_{\text{input}} = 4.58 \text{ W}$ $\dot{Q} = 11.86 \text{ W}$ (heat removed from cabinet)	240 V (AC)	2.59	--	grid-connected	- domestic use
Kattakayam and Srinivasan, 2000 [101]	VCR	Conventional domestic refrigerator	165	CFC 12 refrigerant $\dot{Q}_c = 100 \text{ W}$ $E = 840 \text{ Wh}$ 8 PV panels of 70W four 6 V x 180 AH lead acid deep discharge tubular batteries pulse width modulated (PWM) inverter	170-270 V (AC)	2.85	From solar energy to compressor: 4.5% (average)	indirectly powered by the PV	- vaccine storage applications
Modi et al., 2009 [102]	VCR	Conventional domestic refrigerator	165	R134a refrigerant Two 12 V-135 A h lead-acid batteries 4 PV panels 35Wp (REIL, mono-crystalline silicon) Battery at 12 V DC to AC inverter	160-250 V (AC)	2.102 (max)	--	indirectly powered by the PV	- off-grid applications
Gupta et al., 2014 [103]	VCR	Conventional domestic refrigerator	50	R134a refrigerant PV panel 35Wp 1.5 kVA inverter Battery at 24 V DC to AC inverter	220-240 V (AC)	--	--	indirectly powered by the PV	- domestic use
Akinola et al., 2015 [104]	VCR	Hawking refrigerator	40	A 12 V, 500 Ah deep cycle battery PV module Charge regulator Battery at 12 V DC to AC Inverter	220 V (AC)	4.73	--	indirectly powered by the PV	- domestic use in off-grid areas
Samar et al., 2015 [105]	VCR	Modified commercial refrigerator	20	R134a refrigerant $T_{\text{cabinet}} = -40 \div 4^{\circ}\text{C}$ Compressor 90 W 3PV panels, 125 Wp Battery at 12 V, 7 Ah DC to AC Inverter	230 V (AC)	3.37	10% (PV only)	indirectly powered by the PV	- rural and off-grid areas

Reference	Technology	Unit type	Capacity (litres)	Description	Voltage	COP	System efficiency (%)	Comments	Applications
Field, 1980 [106]	TER	prototype	3.6	TEC (12 W) $T_{\text{cabinet}} = 0^{\circ}\text{C}$ $\eta_{\text{PV}} = 0.15$ Storage Battery ($C = 70\text{Ah}$)	18V (DC)	0.12	--	PV powered	medicine storage
Sofrata, 1984 [107]	TER	prototype	231	2 TEM High-density collectors ($P=33\text{ W}$; 64 cell/collector; 32 cells in series); Low-density collectors ($P=20\text{ W}$; at nominal 12 volts; 36 cell/collector)	12 V (DC)	--	--	PV powered	medicine storage, food
Bansal and Martin, 2000 [74]	TER	--	40	TECs $P_{\text{input}} = 13.75\text{ W}$ TER ($T_{\text{cabinet}} = 5^{\circ}\text{C}$)	110 V (AC)	0.69	--	grid connected	on-grid applications
Dai et al., 2003a [108], Dai et al., 2003b [109]	TER	Prototype	--	TEM ($P=45\text{W}$) TER ($T_{\text{cabinet}} = 5 \div 10^{\circ}\text{C}$) PV ($\eta_{\text{PV}} = 0.13$) Storage battery ($C = 100\text{Ah}$)	12 \div 24V (DC)	0.3	--	PV powered	cold storage of vaccine, foodstuffs and drink in remote areas - outdoor for off-grid applications
Abdul-Wahab et al., 2009 [110]	TER	Prototype	13	TEM (10 TECs) TER ($T_{\text{cabinet}} = 5^{\circ}\text{C}$) 64 PV ($\eta_{\text{PV}} = 0.14$) $P = 115.2\text{ W}$	12 \div 24V (DC)	0.16	--	PV powered	off-grid areas
Min and Rowe, 2006 [111]	TER	Prototype	115/115/40	$T_{\text{cabinet}} = 5^{\circ}\text{C}$ 2 Heat exchangers Temperature controller	(DC)	0.3-0.5	--	grid connected	domestic refrigerator
Saidur et al., 2008 [112]	TER	--	--	TER ($P=22\text{W}$) $T_{\text{cabinet}} = 1 \div 7^{\circ}\text{C}$ 4 PV ($P_p = 100\text{W}$) 4 Storage batteries ($C= 100$ Ah) Solar charge controller ($I =$ 12A) Inverter ($P = 150\text{W}$, $V = 24\text{V}$)	12 \div 24V (DC)	--	--	PV powered	domestic usage
Vián and Astrain, 2009a [113]	TER	Prototype	225	2 TEM TER ($T_{\text{cabinet}} = 5^{\circ}\text{C}$) A thermosyphon, with two- phase and capillary lift (TPM) A thermosyphon, with two- phase without moving parts (TSV)	12V (DC)	0.45	--	grid connected	camping vehicles, buses, special transports for electro medicine

4. Electrical power systems: microgrids

The electrical power system has a central role in the evaluation of performance of thermoelectric refrigerators, in particular in extreme conditions. Lately, microgrids have obtained a great success for many reasons described in this section. The idea of microgrid is not new; in fact, the general definition of microgrid is due to Lasseter in 2002 [114], who defined the microgrid as a “a cluster of loads and microsources operating as a single controllable system that provides both power and heat to its local area”. Microsources may include distributed generation units and storage systems and they supply loads through an internal, low-voltage (LV) electric network. One peculiarity of microgrids is that they may operate in connection with a medium-voltage (MV) distribution network (“grid-connected mode”), independently (“island mode”), or in both modes.

The U.S. Department of Energy has recently defined the microgrid as a “a group of interconnected loads and distributed energy resources (DERs) with clearly defined electrical boundaries that acts as a single controllable entity with respect to the grid and can connect and disconnect from the grid to enable it to operate in both grid-connected or island modes” [115]. DERs can be distributed generators and energy storage that have the possibility to supply locally the loads.

Indispensable peculiarities of a microgrid are the definition of its electrical boundaries and the presence of a master controller, which controls and operates available resources.

The DERs may include several technologies for the generation of electrical energy (e.g., wind turbines and solar photovoltaic (PV) panels are the most common ones, but also geothermal, tidal, waves, small hydro, biomass, biogas, internal combustion engines, fuel cells and micro-turbines can be considered) and for the electrical storage systems (e.g., several typologies of batteries, flywheels and super-capacitors). Moreover, thermal storage is a well-developed technology to store energy in an economic way through ice storage or hot water storage [116].

Of course, the units based on Renewable Energy Sources (RES) are generally more environmentally sustainable [117]. These technologies, which can be effectively deployed in a microgrid framework, are considered as one of the most effective solutions for the population without access to energy or with poor energy supply. It is also worth noting that the massive and broad use of the mentioned technologies will help cutting the greenhouse gas emissions and limiting the environmental impact in case of emergency or provisional installations.

The internal LV electric network can distribute power in alternating current (“AC microgrids”), in direct current (“DC microgrids”) or can have two sections, one in AC and one in DC (“hybrid AC/DC microgrids”).

4.1. AC microgrids

Generation units producing AC output power (e.g., wind turbines, hydro) are connected either directly or by means of AC/DC/AC power converters to enable their stable coupling with the AC networks. Generation units producing the DC power output (e.g. solar PV arrays, fuel cells) and some energy storage devices can be connected to the AC electrical network by means of a proper electronic interface.

The loads that need to be fed with AC are directly connected to the AC network; on the other hand, the loads that need to be fed with DC are connected to the AC network by means of a proper power electronic converter.

Specific issues related to the AC microgrids, such as their operation and control, the power quality and the adequate protection, are treated in many references. For instance, a review on these specific aspects can be found in [118].

A general scheme of an AC microgrid is shown in Fig. 7a.

4.2. DC microgrids

Recently, the solution of microgrids with internal LV electric network in DC is gaining much consideration from the international scientific community. DC microgrids are also recognized as an effective solution to provide electricity in areas where the electric infrastructure are not sufficient or are not existent [119].

One of the reasons is based on the fact that most of renewable based generation units directly produce DC and many consumer devices need DC power for their operation (e.g., computers, LED lights, household equipment, and batteries of electrical vehicles). When connected to an AC electrical network, the required DC-AC-DC power conversion stages lead to energy losses along with a plenty of power converters.

In a DC microgrid, the generation units producing the DC power output, some energy storage devices and DC loads are connected directly to the DC electrical network. On the other hand, the AC power generating units and the AC loads need a power electronic based interface for the connection to the DC electrical network.

The expected advantages of the realization of DC distribution systems that can be considered valid also for DC microgrids are [117]:

- The improvement of the power distribution network.
- The higher power quality levels that can be assured to the customers.
- The connection of generating units will be easier.

The possibility to integrate directly into the power converter measuring instruments such as advanced metering infrastructures (AMIs), demand energy managements (DEMs) and protection systems.

A general scheme of a DC microgrid is shown in Fig. 7b. In the scheme, DC/DC converters are represented with dashed borders because their presence is dependent on the voltage levels used in the microgrid.

4.3. An example of microgrid application in emergency or humanitarian conditions

An example of a micro-grid application for development assistance is described in [120]. Originally, the ZeroBase Energy's project was designated for a refugee camp in Lokichoggio, Kenya consisting in a battery (lead acid) packaged container off-grid solar hybrid system. To date, the generators have never supplied power to the resident population. The requests were 80 kW of solar PV; 360 kWh of lead acid battery storage; 100 kW power management system to include (i) 100kW Grid-Tied Inverter Bi-directional (GTIB) for PV integration and (ii) GTIB for battery integration; management, control and synchronization of the two existing generators; 20 foot ISO container to house all power output components.

Rural developing regions are considered suitable for the implementation of microgrids and there have been many projects in these areas [33], [121]. In fact, microgrids can help integrate distributed non-grid controlled generation and improve quality of service [77], [78], [122].

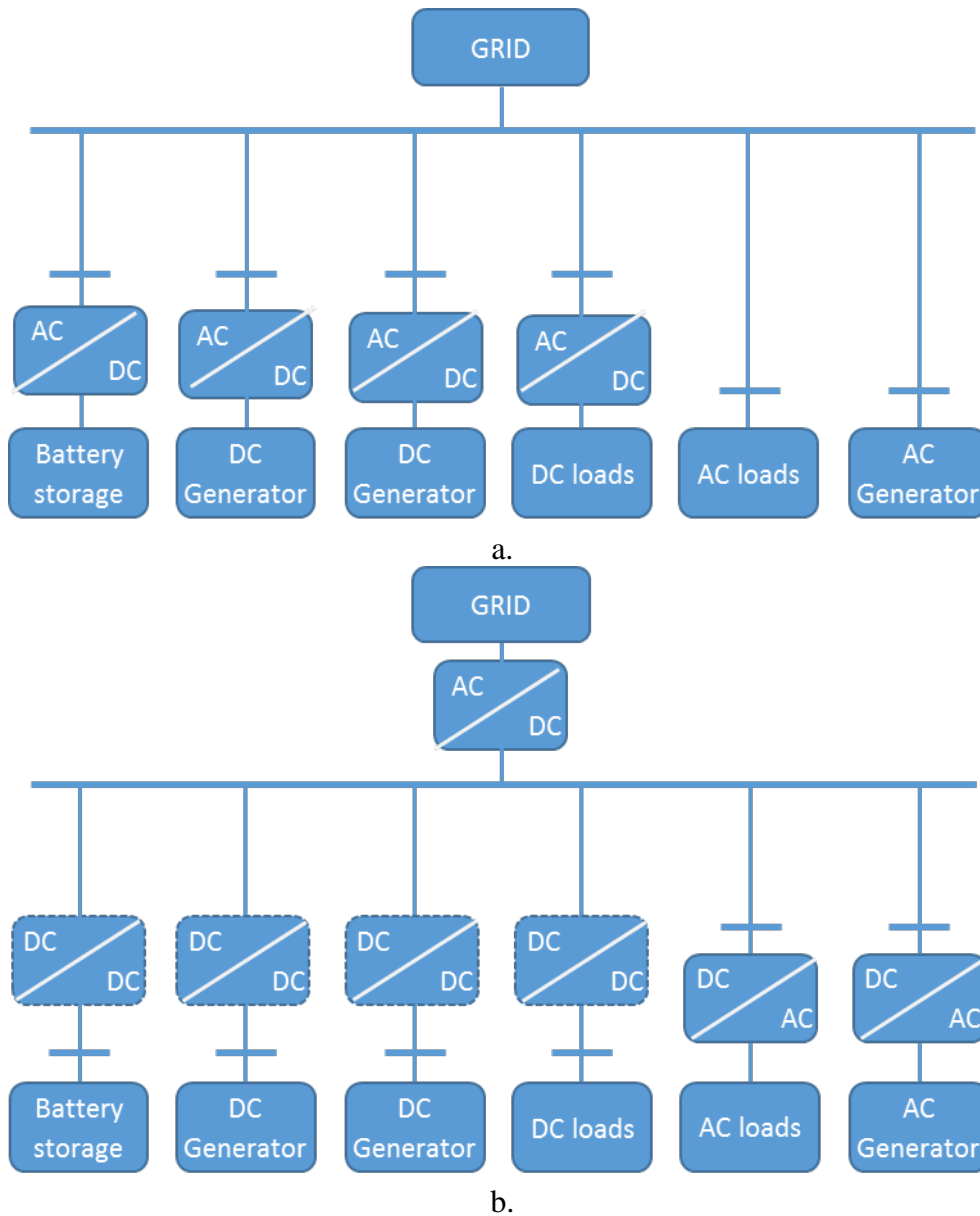

Fig. 7. Schematic illustration of an AC microgrid (a) and of a DC microgrid (b)

5. Experimental measurements on the thermoelectric refrigerator

In this Section, an experimental setup made by the Authors is presented. The setup has a twofold aim. On one hand, it aims to present a small application of TERs, by emulating the filling and the discharge of the refrigerator with bottles of water. On the other hand, the use of the setup allows the electrical load characterization, that is useful for understanding the behaviour of the refrigerator, and thus how to couple it with PV generators and batteries.

5.1. Experimental setup

In order to study the operation of a commercial TER, the equipment shown in Fig. 8 has been tested. This device is supplied by the AC grid and the maximum consumption corresponds to 50 W at a rated voltage of 230 V and frequency of 50 Hz. This appliance has a capacity of 42 l (external sizes 42x42x50 cm) and contains an insulation compartment with upper and bottom thickness of 6 cm, and lateral thickness of 4 cm.



Fig. 8. AC-supplied TER.

The system for real-time data acquisition used in this paper is an Automatic Data Acquisition System (ADAS), adequate to measure the electric parameters (e.g., voltage, current, instantaneous active, reactive and apparent power and the power factor) and the environmental parameters (e.g., relative humidity, RH , and internal and external temperatures). The uncertainties of measurements, declared by the manufactures, are $\pm 0.3\%$ of the readings ± 3 digits for electric parameters, $\pm 0.5^\circ\text{C}$ for temperature and $\pm 3\%$ for RH .

5.2. Characterization of the electrical consumption of a thermoelectric refrigerator

For performing the measurement of energy consumption, the TER has been installed in a basement, characterized by a quite constant temperature T_{external} , without any control; during the experiment, the ambient temperature T_{external} resulted 23°C with a variation of $\pm 0.5^\circ\text{C}$. The internal temperature set-point $T_{\text{set-point}}$ can be regulated: in the abovementioned conditions (i.e., $T_{\text{external}} \approx 23^\circ\text{C}$) the refrigerator reached an internal temperature between $\approx 8^\circ\text{C}$ (working at max power) to 15°C (corresponding to the minimum consumption).

The experiments started with the empty refrigerator at the temperature set-point; the refrigerator compartment has been progressively filled with 1 litre of water at ambient temperature (i.e., about 23°C), up to reaching the maximum capacity of 7 l. Furthermore, the next litre of water has been added after the refrigerator reached the initial temperature set-point, while the quantity of the previously cooled water remained in the refrigerator. The time needed to cool the water was dependent on the temperature set-point varying from about 3 to about 6 hours. All the data regarding both the electrical consumption and the environmental data (i.e., temperature and humidity) have been collected every second.

Three case studies have been analysed to evaluate the effect of several values of internal temperature set-points:

- Case 1 “high power condition”, with the internal temperature set-point fixed at about 8°C ;
- Case 2 “intermediate power condition”, with the internal temperature set-point fixed at about 11°C ;
- Case 3 “low power condition”, with the internal temperature set-point fixed at 15.5°C .

Fig. 9 shows the active power required by the refrigerator in Case 3 (with blue colour) over a time interval of 40 hours; in the same graph, the internal temperature is also shown (with orange colour). From the graph, the following considerations arise:

- The internal temperature has a rise of about $2 - 3^\circ\text{C}$ when a further bottle of water is introduced inside the compartment. After a while, the internal temperature begins to decrease until the set-point value.
- The active power required by the refrigerator exhibits a sudden rise according to the internal temperature rise and reaches the nominal value (i.e., 50 W); the active power, then, exponentially decreases following the behaviour already described in Section 3.2.

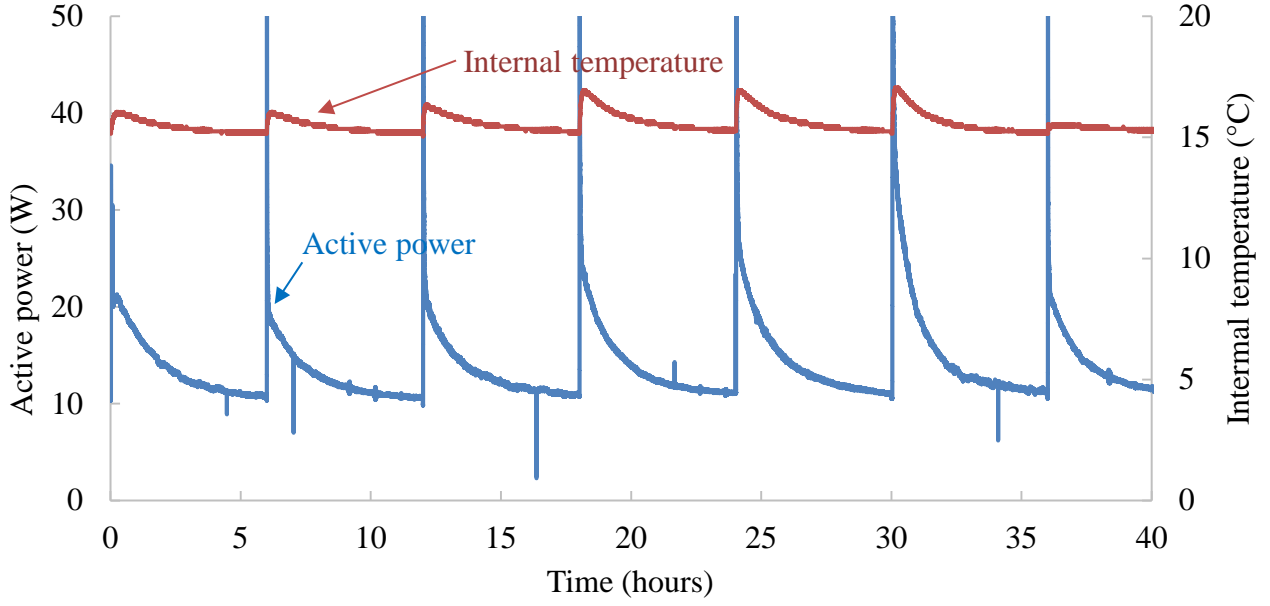

Fig. 9. Progressive filling of the TER: active power and internal temperature versus time (Case 3)

In Case 1 and in Case 2, similar graphs were obtained and, then, are not represented here.

During each time interval of 6 hours, the TER cooled the additional one litre of water (from $\approx 23^\circ\text{C}$ to the internal temperature set-point) and kept constant the internal temperature.

In order to characterize the energy efficiency of the TER, a simplified analysis has been conducted.

First of all, it has been evaluated the theoretical energy $E_{cooling}$ needed to cool 1 litre of water, according to the following expression:

$$E_{cooling} = m \cdot C_p \cdot \Delta T \quad (1)$$

where:

- m is the mass (in kg) corresponding to 1 litre of water, approximated to unity for temperatures in the range $5\text{--}25^\circ\text{C}$;
- C_p is the specific heat at constant pressure approximated as $4.19 \text{ kJ}/(\text{kg}\cdot\text{K})$ for temperatures in the range $5\text{--}25^\circ\text{C}$;
- ΔT (in $^\circ\text{C}$) is the difference between the initial temperature of water (when it has been introduced in the compartment) and the internal temperature set-point.

Since the initial temperature of water is the ambient temperature, that is, the external temperature, equation (1) becomes:

$$E_{cooling} = m \cdot C_p \cdot (T_{external} - T_{set-point}) \quad (2)$$

Then, the electrical energy absorbed $E_{absorbed}$ by the refrigerator is evaluated as the integral of the measured active power required by the refrigerator over the time interval of 6 hours.

To evaluate the performance of the TER in different conditions, the efficiency ε_w is introduced:

$$\varepsilon_w = \frac{E_{cooling}}{E_{absorbed}} \quad (3)$$

The efficiency (3) has been evaluated in the three case studies, to observe the effect of the internal temperature set-point.

Fig. 10 shows the ratio ε_w versus the temperature difference ΔT : in all the three case studies, the points represent the additional litres of water. With respect to each case study, it is worth noting that the points have different values of ΔT because the ambient temperature is not perfectly constant,

as well as the internal temperature of the conservation compartment; moreover, the value of ΔT also depends on the uncertainties of measurements. In any case, the variation range is very small.

A consideration about the graph of Fig. 10 is that the ratio ε_w decreases with the increase of ΔT . In particular, the ratio ε_w decreases from about 11% (mean value among the 7 blue points) for the Case 1 to about 7% (mean value among the 7 orange points) for the Case 3. Furthermore, a 46% reduction of the internal temperature set-point leads to a reduction of the mean value of ratio ε_w at about 57%. In conclusion, it is confirmed the well-known non-linear efficiency trend for all cooling devices when ΔT increases. The cooling efficiency depends on ΔT and, in particular, the cooling efficiency decreases when ΔT increases [47].

Another experiment has been carried out by filling the empty refrigerator with 7 l of water at the same time and the results are that similar values of the ratio ε_w are obtained with respect to the previous case study. No correlation between the ratio ε_w and the amount of water has been obtained, even if the needed time for cooling is longer.

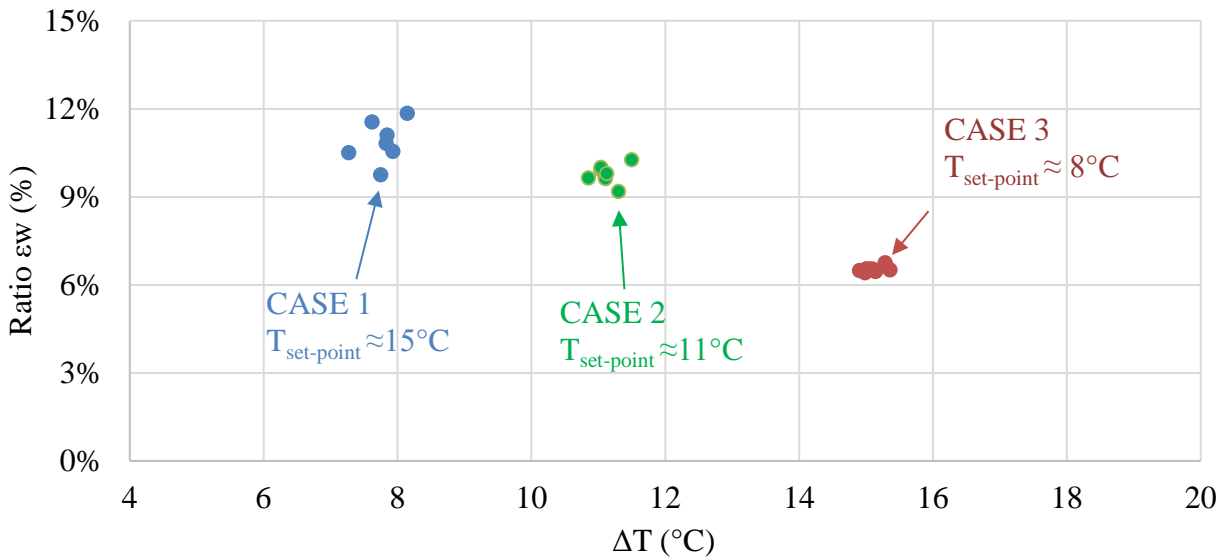

Fig. 10. Chart of temperature difference ΔT versus the ratio ε_w ($T_{external} = 23 \pm 0.5^\circ\text{C}$)

Table 2 summarizes the main data related to the abovementioned case studies.

Table 2 - Values referring to the three case studies.

Average values	Case 1	Case 2	Case 3
$T_{external}$ [°C]	23.1	22.8	23.2
$T_{set-point}$ [°C]	15.5	11.5	8.2
ΔT [°C]	7.8	11.1	15.1
$E_{cooling}$ [kJ]	32.5	46.4	63.3
$E_{absorbed}$ [kJ]	300	474	981
ε_w	0.11	0.10	0.07

For further characterizing the electric behaviour of the TER, the waveform of voltage and current have been also measured (shown in Fig. 11). In this case, the characteristics of the used ADAS and the measurement uncertainties are reported in [123]. The current waveform has been measured in two different conditions: at higher load (i.e., when the TER requires a high active power, about the rated value) and at lower load (i.e., when the TER requires a low active power). In both cases, the

distortion of the current waveform results high due to the operation of a single-phase converter, while the voltage profile results quite sinusoidal, being imposed by the Distribution Grid Operator (DGO).

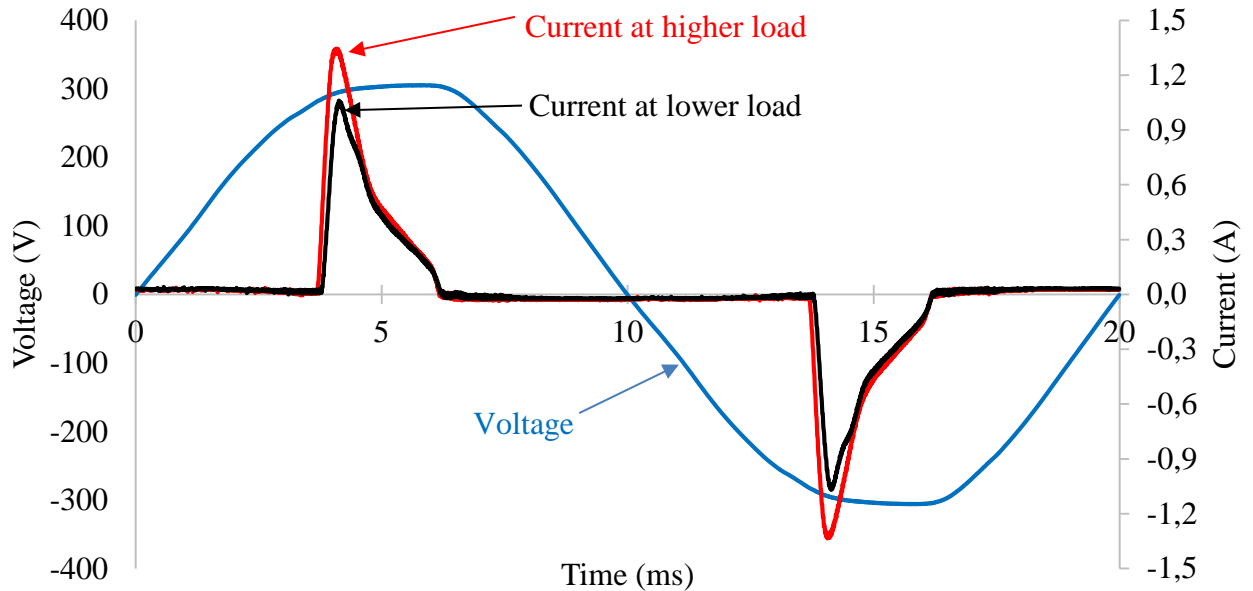

Fig. 11. The voltage and current waveforms versus time.

Finally, the DC voltage-current characteristic of the TEM has been measured, by obtaining the DC consumption of the refrigerator. The test has been performed at ambient temperature $T_{\text{external}}=21^{\circ}\text{C} \pm 1^{\circ}\text{C}$ and $\text{RH} \approx 30\%$, while the internal temperature set-point has been equal to the minimum ($T_{\text{set-point}} \approx 8^{\circ}\text{C}$). The unit has been filled with a bottle of water (0.5 litre) at ambient temperature. The profiles of DC power, voltage and current have been acquired during the thermal transient (≈ 8 hours).

The DC power required by the TEM exhibits a rise when the refrigerator is open and filled with warm water (Fig. 12). The internal temperature rises and the consumption reaches the maximum value (≈ 40 W); then, it decreases exponentially by following the same curve described in case of AC measurements. The profiles of DC voltage and current are identical to the profile of the DC power. As shown in Fig. 13, the voltage-current correlation is linear and the global resistance is $\approx 2.75 \Omega$. At maximum power, the DC supply voltage is $V_{\text{DC,max}} \approx 10.6$ V, while the corresponding absorbed current is $I_{\text{DC,max}} \approx 3.8$ A.

At full load, the consumption of the TEM is about 80% of the total (Fig. 14). The remaining part is related to the auxiliary systems of the refrigerator (fans, AC/DC converter and temperature controller). At low load, the consumption of the TEM decreases down to about 70% (Fig. 14).

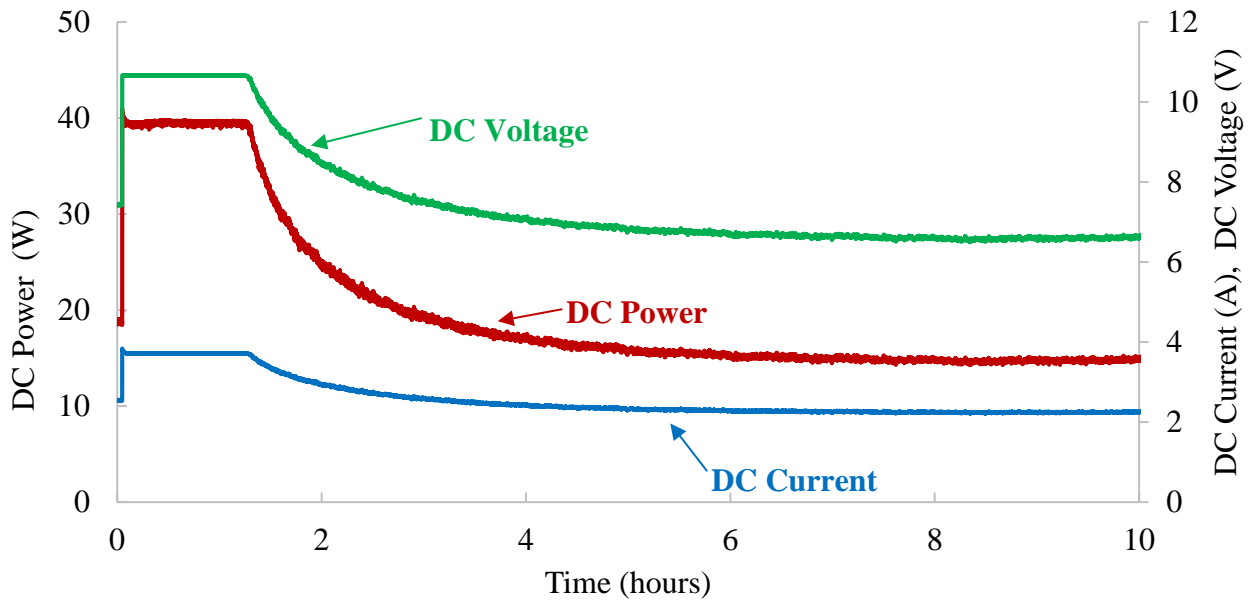

Fig. 12. The DC power, current and voltage profiles of the TEM.

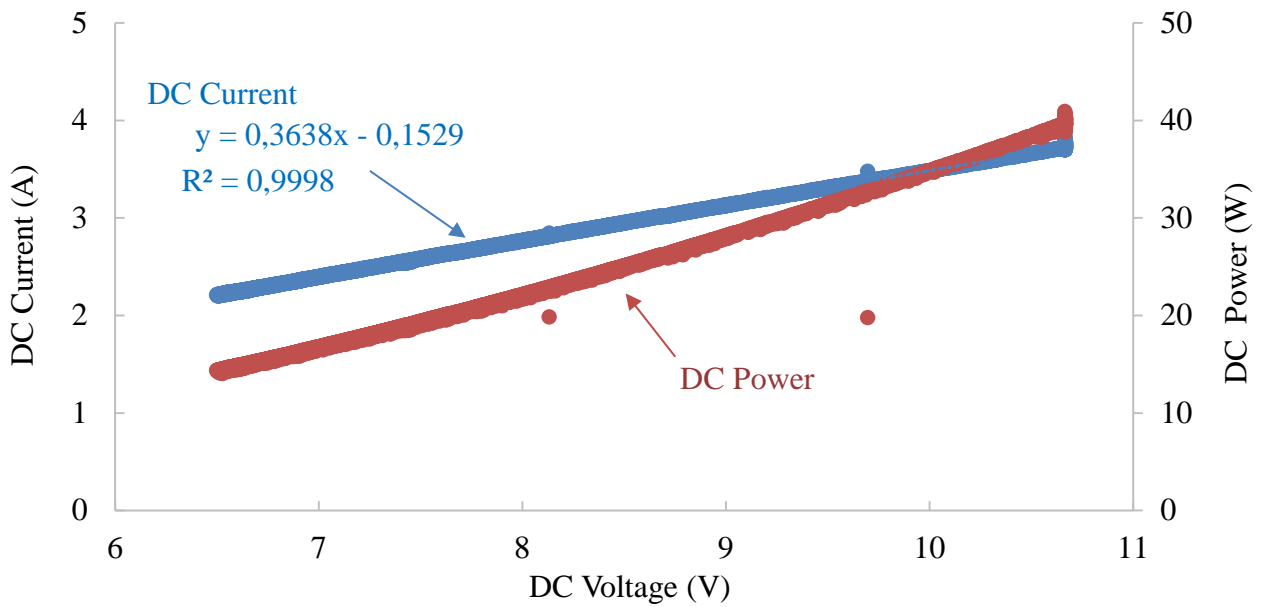

Fig. 13. The DC current-voltage and power-voltage characteristics of the TEM.

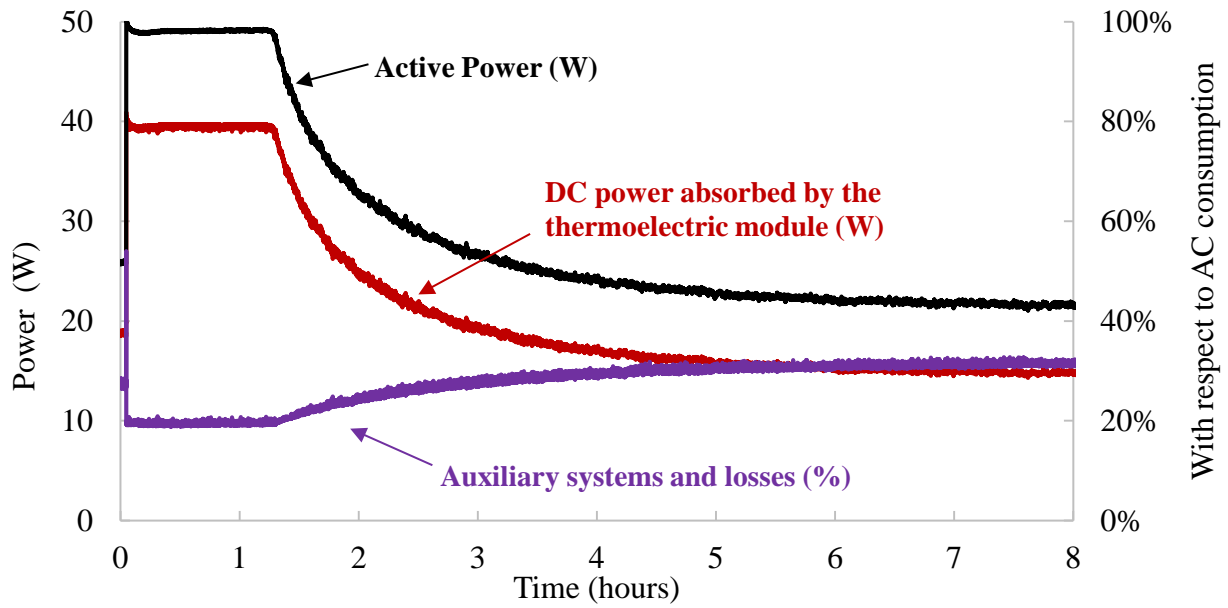

Fig. 14. Comparison between AC supply and DC consumption of TEM.

6. Numerical simulation of a solar PV/battery thermoelectric refrigeration system

The TER is supposed to be installed in a microgrid-like structure, connecting a PV generator and a battery storage, to assess the performance and to highlight the peculiarities of the stand-alone system.

The stand-alone system (not grid connected) is set up according to the scheme reported in Fig. 15. Some of the considered devices (i.e., PV generator and TER) are represented thanks to the real measurements carried out by the authors.

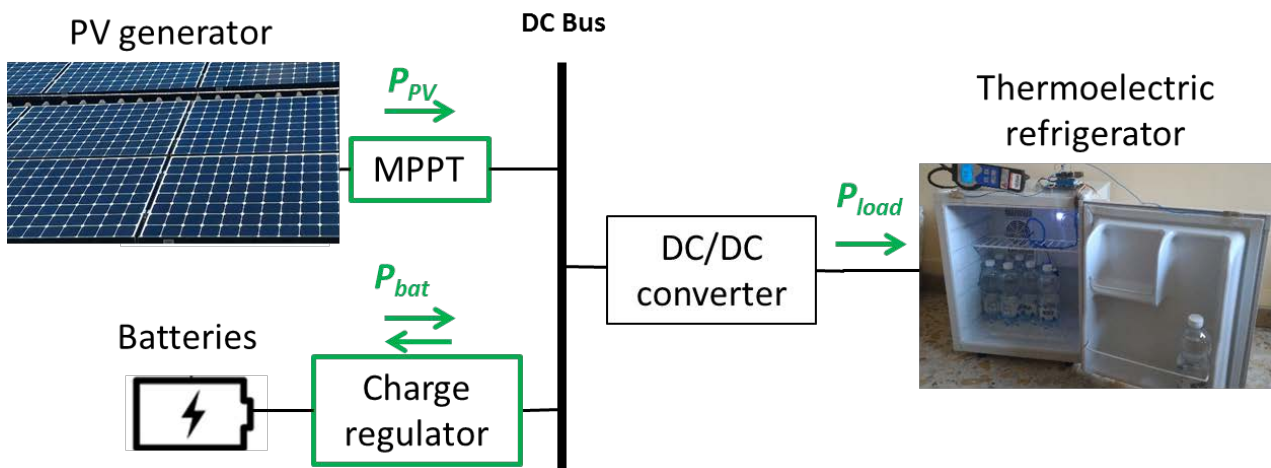

Fig. 15. Scheme of the stand-alone system.

As described in Section 1, refrigerators based on Peltier effect can be directly powered by PV in DC supply, and thus it is possible to connect them to the DC bus by means of a DC/DC converter [124] (for properly adapting the voltage level).

A description of each component of the stand-alone system, as well as their operating conditions, is provided as follows:

- TER: the same appliance of the previous Sections is considered. The unit periodically is filled with 7 l of water, such that the water temperature varies from about 23°C to 8°C. The

time requested for this variation is about 34 hours. Once the water reached the temperature set-point, the refrigerator is emptied and the process restarts.

- the PV plant is composed of poly-crystalline silicon modules and installed in the urban area of Turin (Italy), at latitude 45° . The modules present an azimuth angle equal to 90° and a tilt angle equal to 30° . The production measurement was performed during August 2016 with the following characteristics: mean daily air temperature equal to 24°C and mean solar radiation equal to $5.46 \text{ kWh/m}^2/\text{day}$ (both these mean data have been obtained by the PVGIS database [125] referring to typical August). The ADAS collected every minute the data regarding the electrical production. The specific electrical production of the plant (expressed in kWh/kW_p) is expressed as the ratio of the total electrical energy production to the nominal power of the plant. To simulate other plants with different sizes and similar characteristics (i.e., site, azimuth, and tilt), the specific production is multiplied to the nominal power of the simulated plant [126]. Fig. 16 shows the specific production of the considered plant (in blue line). The AC production lies in a range between $2.8 \text{ kWh/kW}_p/\text{day}$ (cloudy and slightly raining day) and $5.3 \text{ kWh/kW}_p/\text{day}$ (clear and sunny day). The value of minimum production (observed at the 10th day) is considered as a constraint for the sizing of the stand-alone system.

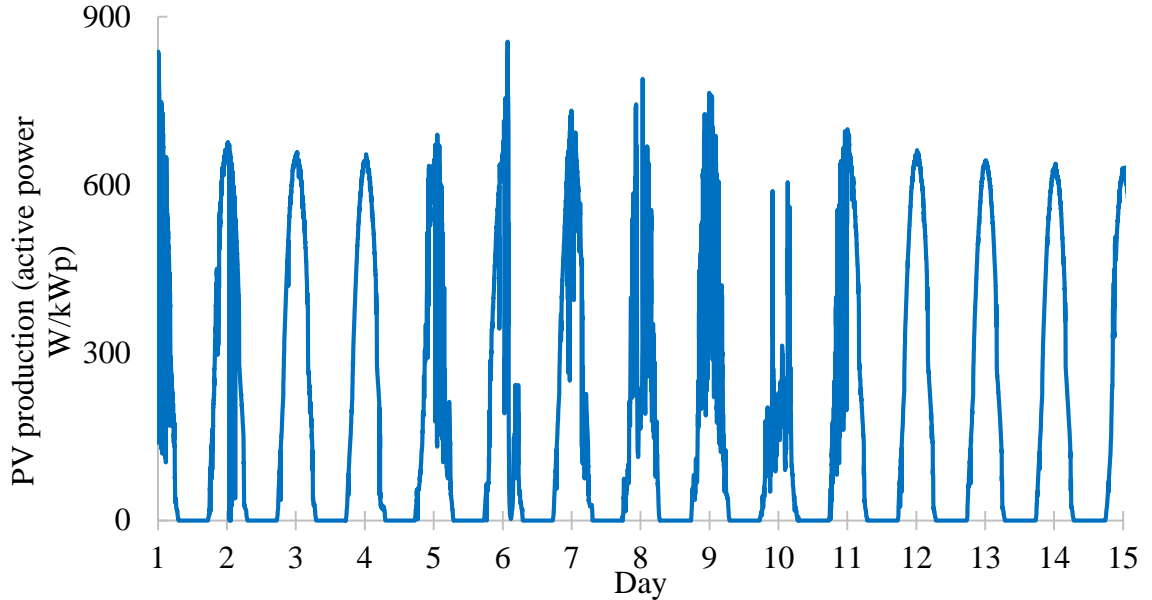

Fig. 16. Specific PV production during the measurement period (August 1-15, 2016)

- Lithium (Li-Ion) battery: the behaviour of the battery is simulated by means of a simplified energy model [127]. At every time τ , the State-Of-Charge (*SOC*) is updated, by considering the *SOC* at the instant $(\tau - \Delta\tau)$ and charge/discharge efficiency η_{bat} , as follows:

$$SOC(\tau) = SOC(\tau - \Delta\tau) - \eta_{bat} \cdot P_{bat} \cdot \Delta\tau / (V_{bat,r} \cdot C_{bat,r}) \quad (4)$$

with $V_{bat,r}$ and $C_{bat,r}$ indicating the nominal values of voltage (in V) and capacity (in Ah) of the battery. P_{bat} is the value of battery power (in W), assumed to be positive in discharge phase and negative in charge phase.

The *SOC* at every time τ is constrained between a minimum value SOC_{min} and a maximum value SOC_{max} :

$$SOC_{min} \leq SOC(\tau) \leq SOC_{max} \quad (5)$$

The minimum and maximum values are usually $SOC_{min}=0.2$ and $SOC_{max}=1$, respectively. The maximum value of power provided by the battery is another constraint for preserving its lifetime. Table 3 depicts the most important data related to a Li-ion battery (single element).

Table 3. Specifications of a Li-ion Battery module

Battery capacity	$C_{bat,r}$	100 Ah
Rated voltage	$V_{bat,r}$	12 V
Lifetime ¹ (cycles)	N_{cycles}	3500 cycles, 1 per day, $DoD=80\%$
Lifetime ¹ (years)		8
Maximum power	$P_{bat,max}$	≈ 2.4 kW
Charge-discharge efficiency	η_{bat}	0.88

¹. Warranty, real lifetime most likely higher. DoD is the Depth of Discharge.

- DC/DC converter, to adapt the voltage levels of the DC bus and of the refrigerator. For sake of simplicity, the efficiency of this conversion unit is supposed to be unitary.

In order to simulate the stand-alone system, it is necessary to size the PV plant and the batteries, with the aim of supplying the TER without any connection to the external grid. Because the refrigerator is supplied in any condition (i.e., the energy balance has to be always guaranteed), the system is sized taking into account the worst day in terms of solar radiation (i.e., the rainy day).

First of all, the PV generator of the system is sized. The energy requested by the load and the PV plant production are compared and the energy surplus or deficit (defined as the difference between the production and the load) is evaluated. The energy surplus stored in the batteries is used when the generator cannot completely supply the load (e.g., during the night).

The power balance is expressed as:

$$P_{PV} + P_{bat} = P_{refrigerator} \quad (6)$$

where P_{PV} is the PV power and $P_{refrigerator}$ is the refrigerator power.

The system is sized for continuously operating in a time period of 15 days, by considering the specific production for the worst day (i.e., 2.8 kWh/kWp) and the mean daily consumption of the refrigerator is 1.04 kWh. The theoretical PV size based on these data is:

$$P_{PV}^{(th)} = \frac{\text{Meandaily consumption of the refrigerator}}{\text{Specific PV production in the worst day}} \approx 370W \quad (7)$$

After the PV system sizing, the capacity of the battery is defined, such that the surplus of energy is stored and successively used for supplying the refrigerator when the PV production is not sufficient.

The stand-alone system operation is simulated over a time period of 15 days: the minimum required capacity is 1300 Wh, corresponding to about 30 hours of autonomy with an average consumption of 43 Wh.

The results of the simulation are shown in Fig. 17 and Fig. 18.

The state of charge of the battery, shown in Fig. 17, does not fall down the minimum value $SOC_{min} = 20\%$, even if this value is approached in the rainy day.

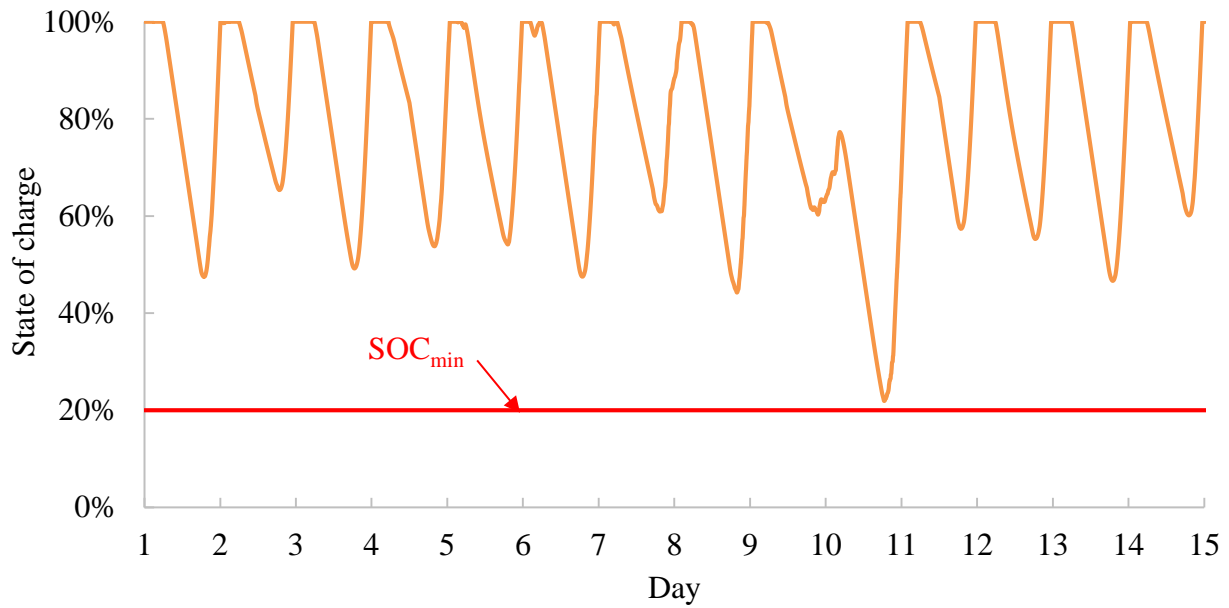

Fig. 17. State of charge of the battery during the 15 days of simulation

Fig. 18 shows the trends of powers simulated in two days: the 10th day, that is the worst day in terms of solar radiation, and the 11th day. During the 10th day, the battery discharge lasts all the day, by approaching the SOC_{min} . Conversely, the day after is sunny and the battery is completely recharged in the late afternoon. The battery charge profile (in red) drops off at zero during the 11th day, implying that the storage is full.

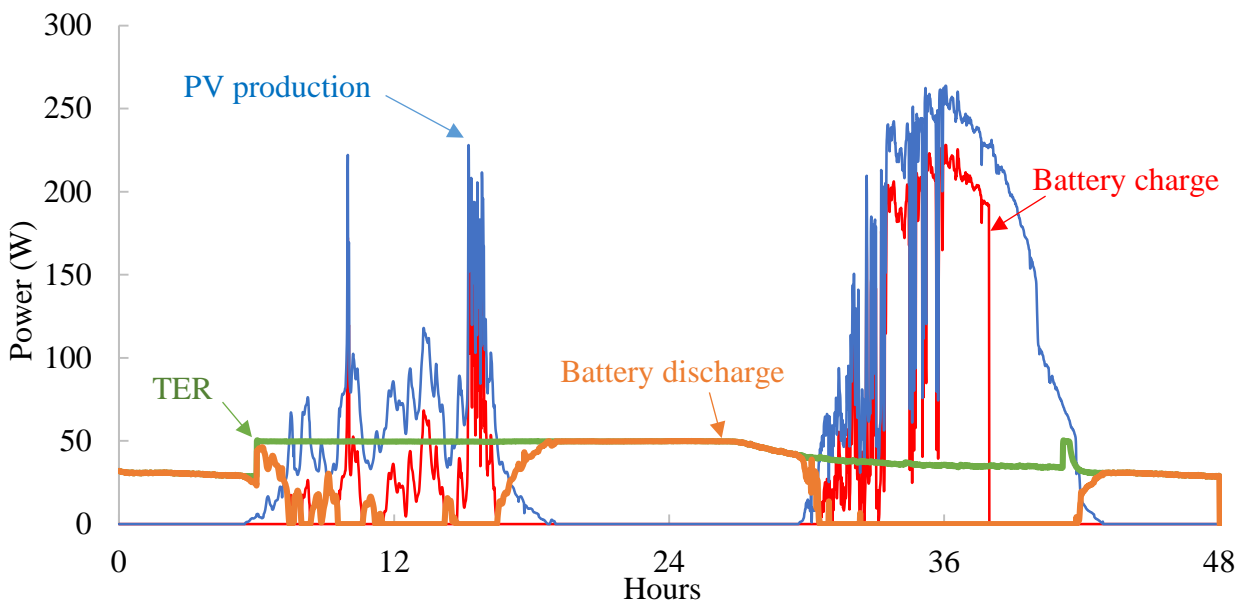

Fig. 18. Power profiles in two days of simulation (10th and 11th day)

7. Conclusions and future work

Due to the environmental conditions, some types of local energy systems (such as the temporary camps in humanitarian contexts) require specific installations and operation modes of the equipment connected to the local system. The use of thermoelectric cooling appears as an effective refrigeration technology, thanks to its positive characteristics (e.g., absence of refrigerant and mechanical vibrations, easy to be moved, flexibility, low noise, possibility to be operated in any position,

accuracy of the temperature control). For instance, a recent pilot project in Lebanon (a camp for Syrian refugees) has installed 13 small TERs (20-25 litres each) [3].

This paper focuses on the electrical characteristics of a TER connected to the power grid in a microgrid-like installation particularly useful for humanitarian context. The operation of the TER has been tested in different operating conditions through a series of experiments, by measuring the electrical and environmental values with fast time resolution (1 second). The results obtained show the characterization of the TER. In particular, the operational mode based on continuous exponential-like transients is totally different with respect to a vapour compression refrigerator operating in intermittent mode with on-off cycles.

The TER analysed is AC supplied. Thereby, the testing has been carried out with AC grid connection. However, intrinsically the TER operates with DC and the potential application of this refrigerator connected to DC networks or microgrids is an interesting aspect for the applications described in this work. Therefore, the profiles of DC power, current and voltage of the TEM have been also measured.

A sustainable solution in which the TER is supplied by a photovoltaic plant and equipped with an electric storage system has been identified. Sizing and simulation of this solution have been carried out.

Such solutions appear adequate in areas where the electrification is not developed and renewable energy sources are largely available. These results may be useful to deal with a particular type of local energy system, such as the temporary camps used in the humanitarian context.

Future work is being developed in different directions. A first aspect is the characterization of the TER from the point of view of its energy efficiency in variable operational conditions. Furthermore, the experimental testing of DC-supplied TERs is useful to study DC microgrids incorporating all the equipment used in a humanitarian camp for lighting, cooking, refrigeration, and so forth. This study will also contain the design of the microgrid structure and the suitable sizing of the microgrid with photovoltaic generation and battery storage, taking into account possible consumption scenarios.

Acknowledgments

The authors thankfully acknowledge prof. Marco Carlo Masoero of Politecnico di Torino, Dipartimento Energia, for his useful suggestions.

References

- [1] Evans J. Technologies to reduce refrigeration energy consumption in the food industry. *Handbook of Waste Management and Co-Product Recovery in Food Processing* 2009; 2:196–220.
- [2] Mattarolo L. Refrigeration and food processing to ensure the nutrition of the growing world population. *Progress in the Science and Technology of Refrigeration in Food Engineering*. In: *Proceedings of meetings of commissions B2, C2, D1, D2–D3, September 24–28, 1990, Dresden (Germany), Institut International du Froid, Paris (France), 43–54.*
- [3] Barbieri J, Colombo E, Ndam Mungwe J, Riva F, Berizzi, Bovo C, Brivio C, Mandelli S, Merlo M, Gladson Moshi G, Adhikari R, Aste N, Del Pero C, Leonforte F, Caniato M, Set 4 food project – Sustainable Energy Technologies for food utilization, 2014 (online: www.set4food.org).
- [4] Gorris LGM, Peppelenbos HW. Modified Atmosphere and Vacuum Packaging to Extend the Shelf Life of Respiring Food Products. *HortTechnology* 1992; 2(3): 303–9.
- [5] Quintavalla S, Vicini L. Antimicrobial food packaging in meat industry. *Meat Science* 2002; 62:373–80.
- [6] Rahman MS. *Handbook of food preservation–Second Edition*. CRC Press, Taylor & Francis Group, 2007.
- [7] Dhankhar P. A study on refrigeration. *International Journal of Science and Research (IJSR)* 2012; 1212–20.

- [8] Lewis JS, Chaer I, Tassou SA. Reviews of Alternative Refrigeration Technologies. Centre for Energy and Built Environment Research School of Engineering and Design Brunel University 2007; 100–4.
- [9] Tassou SA, Lewis JS, Ge YT, Hadaway A, Chaer I. A review of emerging technologies for food refrigeration applications. *Applied Thermal Engineering* 2010; 30(4): 263–76.
- [10] James SJ, James C. Improving energy efficiency within the food cold-chain. 11th International Congress on Engineering and Food (ICEF 2011), Athens, Greece, 22–26 May 2011.
- [12] Allouhi A, Kousksou T, Jamil A, Bruel P, Mourad Y, Zeraoui Y. Solar driven cooling systems: An updated review. *Renewable and Sustainable Energy Reviews* 2015; 44:159–81.
- [13] Zeyghami M, Goswami DY, Stefanakos E. A review of solar thermo-mechanical refrigeration and cooling methods. *Renewable and Sustainable Energy Reviews* 2015; 51:1428–45.
- [14] Abdul-Wahab SA, Elkamel A, Al-Damkhi AM, Al-Habsi IA, Al-Rubai'ey HS, Al-Battashi AK, Ali R. Al-Tamimi AR, Al-Mamaria KH, Chutani MU. Design and experimental investigation of portable solar thermoelectric refrigerator. *Renew. Energy* 2009; 34: 30–34.
- [15] Xi H, Luo L, Fraisse G. Development and applications of solar-based thermoelectric technologies. *Renew Sustain Energy Rev* 2007; 11: 923–36.
- [16] Omer SA, Riffat SB, Xiaoli Ma. Experimental investigation of a thermoelectric refrigeration system employing a phase change material integrated with thermal diode (Thermosyphons). *Renewable Energy* 2001; 21:1265–71.
- [17] Marques AC, Davies GF, Maidment GG, Evans JA, Wood ID. Novel design and performance enhancement of domestic refrigerators with thermal storage. *Applied Thermal Engineering* 2014, 63: 511–19.
- [18] Sideny S, Lal D M. Exergy analysis of a solar PV driven DC refrigerator for different ambient conditions. Proc.of International Conference on Energy Efficient Technologies for Sustainability (ICEETS), 7-8 April, 2016, India.
- [19] Zhang P, Liu QS, Wang RZ. Performance and applicability of a DC refrigerator powered by the photovoltaics. *J. Renewable Sustainable Energy* 2010; 2:1–8.
- [20] Laidi M, Abbad B, Berdja M, Chikh M. Performance of a Photovoltaic Solar Container Under Mediterranean and arid Climat Conditions in Algeria. *Energy Procedia* 2012; 18:1452–57.
- [21] Ekren O, Çelik S. Energetic and Exergetic Performance Evaluation of an AC and a Solar Powered DC Compressor – Chapt.33. Sustainability in Energy and Buildings. The series Smart Innovation, Systems and Technologies 2013;22:357–65.
- [22] Opoku R, Anane S, Edwin IA, Adaramola MS, Seidu R. Comparative techno-economic assessment of a converted DC refrigerator and a conventional AC refrigerator both powered by solar PV. *International Journal of Refrigeration* 2016; 72:1–11.
- [23] Kattakayam TA, Srinivasan K. Thermal performance characterization of a photovoltaic driven domestic refrigerator. *Int J Refrig* 2000; 23:190–96.
- [24] Kattakayam TA, Srinivasan K. Lead acid batteries in solar refrigeration systems. *Renew Energy* 2004;29:1243–50.
- [25] Kaplanis S, Papanastasiou N. The study and performance of a modified conventional refrigerator to serve as a PV powered one. *Renew Energy* 2006; 31:771–80.
- [26] Anish M, Anirban C, Bhavesh V, Jyotirmay M. Performance analysis of a photovoltaic operated domestic refrigerator. *Int J Appl Energy* 2009; 86:2583–91.
- [27] Ekren O, Yilanci A, Cetin H, Ozturk HK. Experimental performance evaluation of a PV powered refrigeration system. *J Electron Electr Eng* 2011;8:7–10.
- [28] Mohammed O, Al-Dabbas Awwad. The performance of the first Jordan BadiaS solar powered refrigerator. *J Appl Solar Energy* 2012; 48(3):175–9.
- [29] Nan XG, Cai CS, Li J, Deng Y. Experimental study on a solar photovoltaic DC refrigerator. *J Appl Mech Mater* 2013; 317:109–12.
- [30] Gupta BL, Bhatnagar M, Mathur J. Optimum sizing of PV panel, battery capacity and insulation thickness for a photovoltaic operated domestic refrigerator. *Sustainable Energy Technologies and Assessments* 2014; 7: 55–67.
- [31] Kirchoff H, Kebir N, Neumann K, Heller PW, Strunz K. Developing mutual success factors and their application to swarm electrification: microgrids with 100 % renewable energies in the Global South and Germany. *Journal of Cleaner Production* 2016; 128: 190–200.

- [32] Koirala BP, Koliou E, Friege J, Hakvoort RA, Herder PM. Energetic communities for community energy: A review of key issues and trends shaping integrated community energy systems. *Renewable and Sustainable Energy Reviews* 2016; 56: 722–744.
- [33] Kanase-Patil AB, Saini RP, Sharma MP. Integrated renewable energy systems for off-grid rural electrification of remote area. *Renewable Energy* 2010; 35:1342–9.
- [34] El Bassam N, Maegaard P, Schlichting ML. Distributed renewable energies for off-grid communities 2013;1:15–50.
- [35] Akinyele DO, Rayudu RK, Nair NKC. Development of photovoltaic power plant for remote residential applications: the socio-technical and economic perspectives. *Appl Energy* 2015; 155:131–49.
- [36] Bhattacharyya SC. Mini-grid based electrification in Bangladesh: technical configuration and business analysis. *Renewable Energy* 2015; 75:745–61.
- [37] Lehne J, Blyth W, Lahn G, Bazilian M, Grafham O. Energy services for refugees and displaced people. *Energy Strategy Reviews* 2016; 13–14:134–46.
- [38] Akinyele DO, Rayudu RK. Strategy for developing energy systems for remote communities: Insights to best practices and sustainability. *Sustainable Energy Technologies and Assessments* 2016; 16:106–27.
- [39] McCarney S, Robertson J, Arnaud J, Lorenson K, Lloyd J. Using solar-powered refrigeration for vaccine storage where other sources of reliable electricity are inadequate or costly. *Vaccine* 2013; 31: 6050–57
- [40] [Aprea et al., 2002] Aprea C, Greco A, Maiorino A. An experimental evaluation of the greenhouse effect in the substitution of R134a with CO₂. *Energy* 2012; 45:753–761.
- [41] Devocioğlu AG, Oruç V. Characteristics of Some New Generation Refrigerants with Low GWP. *Energy Procedia* 2015;75:1452–1457.
- [42] Goldsmid JH. Introduction to Thermoelectricity. Berlin Heidelberg: Springer Series in Material Science, 2010.
- [43] Kakac S, Smirnov HF, Avelino MR. Low Temperature and Cryogenic Refrigeration. Springer Science + Business Media BV, 2002.
- [44] Godfrey S. An Introduction to Thermoelectric Coolers. *Electronics Cooling* 1996; 2(3) (online:http://www.melcor.com/tec_intro.html).
- [45] Brown DR, Dirks JA, Fernandez N, Stout TB. The prospects of alternatives to vapor compression technology for space cooling and food refrigeration applications. PNNL, 2010.
- [46] Dincer I, Kanoglu M. Refrigeration systems and applications. Wiley Publishing House, 2010.
- [47] Enescu D, Virjoghe EO. A review on thermoelectric cooling parameters and performance. *Renewable & Sustainable Energy Reviews* 2014; 38: 903–16.
- [48] Evans JA, Foster AM. Sustainable Retail Refrigeration. Wiley-Blackwell Publishing House, 2015. (online:<http://eu.wiley.com/WileyCDA/WileyTitle/productCd-1118927400.html>).
- [49] Riffat SB, Ma X. Thermoelectrics: a review of present and potential applications. *Applied Thermal Engineering* 2003; 23:913–35.
- [50] Chatterjee S, Pandey KG. Thermoelectric cold-chain chests for storing/transporting vaccines in remote regions. *Applied Energy* 2003; 76 (4): 415–433.
- [51] Min G, Rowe DM. Experimental evaluation of prototype thermoelectric domestic-refrigerators. *Applied Energy* 2006; 83 (2):133–52.
- [52] Khattab NM, El Shenawy ET. Optimal operation of thermoelectric cooler driven by solar thermoelectric generator. *Energy Conversion and Management* 2006; 47:407–26.
- [53] [Lee and Su, 2002] Lee YS, Su CC. Experimental studies of isobutene (R600a) as the refrigerant in domestic refrigeration system. *Applied Thermal Engineering* 2002; 22:507–519.
- [54] [Wongwises and Chimres, 2005] Wongwises S, Chimres N. Experimental study of hydrocarbon mixtures to replace HFC-134a in a domestic refrigerator. *Energy Conversion and Management* 2005; 46: 85–100.
- [55] Mohanraj M, Jayaraj S, Muraleedharan C, Chandrasekar P. Experimental investigation of R290/R600a mixture as an alternative to R134a in a domestic refrigerator. *International Journal of Thermal Sciences* 2009; 48:1036–42.
- [56] [Dalkilic and Wongwises, 2010] A.S. Dalkilic AS, Wongwises S. A performance comparison of vapour-compression refrigeration system using various alternative refrigerants. *International Communications in Heat and Mass Transfer* 2010; 37:1340–1349.

- [57] [La Rocca and Panno, 2011] La Rocca V, Panno G. Experimental performance evaluation of a vapour compression refrigerating plant when replacing R22 with alternative refrigerants. *Applied Energy* 2011; 88:2809–2815.
- [58] Yoon WJ, Seo K, Chung HJ, Kim Y. Performance optimization of dual-loop cycles using R-600a and hydrocarbon mixtures designed for a domestic refrigerator-freezer. *International Journal of Refrigeration* 2012; 35: 1657–67.
- [59] Rasti M, Aghamiri SF, Hatamipour MS. Energy efficiency enhancement of a domestic refrigerator using R436A and R600a as alternative refrigerants to R134a. *International Journal of Thermal Sciences* 2013, 74: 86–94.
- [60] Klein SA, Reindl DT. Solar Refrigeration. *Building for the Future, A Supplement to ASHRAE Journal* 2005; 47 (9): 26–30.
- [61] Hameed VM, Hussein MA. Studying the Performance of Refrigeration Units Powered by Solar Panel Solar. *Iraqi Journal of Chemical and Petroleum Engineering* 2013; 14 (1): 39–46.
- [62] Hermes CJL, Barbosa Jr. JR. Thermodynamic comparison of Peltier, Stirling, and vapor compression portable coolers. *Applied Energy* 2012; 91:51–8.
- [63] Wang RZ, Yu X, Ge TS, Li TX. The present and future of residential refrigeration, power generation and energy storage. *Applied Thermal Engineering* 2013; 53: 256–70.
- [64] Mba EF, Chukwunke JL, Achebe CH, Okolie PC. Modeling and Simulation of a Photovoltaic Powered Vapour Compression Refrigeration System. *Journal of Information Engineering and Applications* 2012; 2(10): 1–15.
- [65] Çengel YA, Turner RH. *Thermal–Fluid Sciences*. McGraw–Hill, New York, 2001.
- [66] [Dinçer and Kanoğlu, 2010] Dinçer I, Kanoğlu M. *Refrigeration systems and applications*. Wiley, Chichester, UK, 2010.
- [67] [Jo et al., 2014] Jo SW, Sherif SA, Lear WE. Numerical Simulation of Saturated Flow Boiling Heat Transfer of Ammonia/Water Mixture in Bubble Pumps for Absorption–Diffusion Refrigerators. *Journal of Thermal Science and Engineering Applications* 2014; 6: 1–9.
- [68] [Srikhirin et al., 2001] Srikhirin P, Aphornratana S, Chungpaibulpatana S. A review of absorption refrigeration technologies. *Renewable and Sustainable Energy Reviews* 2001; 5:343–72.
- [69] [Macriss et al., 1988] Macriss RA, Gutraj JM, Zawacki TS. Absorption fluids data survey: final report on worldwide data. *Inst Gas Technol, Chic* 1988, [ORNL/Sub/84-47989/3].
- [70] [Leonzio, 2017] Leonzio G. Solar systems integrated with absorption heat pumps and thermal energy storages: state of art. *Renewable and Sustainable Energy Reviews* 2017;70:492–505.
- [71] Dueñas C, Pilatowsky I, Romero RJ, Oskam A, Finck AP. Dynamic study of the thermal behaviour of solar thermochemical refrigerator: barium chloride–ammonia for ice production. *Solar Energy Materials and Solar Cells* 2001;70(3):401–13.
- [72] Hassan HZ, Mohamad AA. A review on solar cold production through absorption technology. *Renewable and Sustainable Energy Reviews* 2012; 16:5331–48.
- [73] Siddiqui MU, Said SAM. A review of solar powered absorption systems. *Renewable and Sustainable Energy Reviews* 2015; 42:93–115.
- [74] Bansal PK, Martin A. Comparative study of vapour compression, thermoelectric and absorption refrigerators. *International Journal of Energy Research* 2000; 24(2): 93–107.
- [75] Bansal P, Vineyard E, Abdelaziz O. Status of not-in-kind refrigeration technologies for household space conditioning, water heating and food refrigeration. *International Journal of Sustainable Built Environment* 2012; 1:85–101.
- [76] Hassan HZ, Mohamad AA. A review on solar cold production through absorption technology. *Renewable and Sustainable Energy Reviews* 2012; 16:5331–48.
- [77] Huang BJ, Chin CJ, Duang CL. A design method of thermoelectric cooler. *Int. Journal of Refrigeration* 2000; 23: 208–18.
- [78] Huang BJ. Feasibility of thermoelectric device for CPU cooling, in: *Proceedings of the 2nd International Workshop on Non–Compression Refrigeration and Cooling*. Odessa, 2001, 28-31
- [79] Min G, Rowe DM. Improved model for calculating the coefficient of performance of a Peltier module. *Energy Conversion and Management* 2000; 2(41):163–71.
- [80] Yu J, Wang B. Enhancing the maximum coefficient of performance of thermoelectric cooling modules using internally cascaded thermoelectric couples. *International Journal of Refrigeration* 2009; 35:32–9.

- [81] Tassou SA, De-Lille G, Ge YT. Food transport refrigeration – Approaches to reduce energy consumption and environmental impacts of road transport. *Applied Thermal Engineering* 2009; 29:1467–77.
- [82] Simons RE, Chu RC. Application of thermoelectric cooling to electronic equipment: a review and analysis. *Semiconductor Thermal Measurement and Management Symposium. Sixteenth Annual IEEE* 2000; 1–9.
- [83] Cleary M, North MT, Van Lieshout M, Brooks DA, Grimes R, Hodes M. Reduced Power Precision Temperature Control Using Variable Conductance Heat Pipes. *IEEE Transactions on Components, Packaging and Manufacturing Technology* 2013; 3 (12): 2048–58.
- [84] Ishii M, Hibino Y, Hanawa F, Nakagome H, Kato K. Packaging and Environmental Stability of Thermally Controlled Arrayed-Waveguide Grating Multiplexer Module with Thermoelectric Device. *Journal of Lightwave Technology* 1998; 16 (2): 258–64.
- [85] Hodes M. On One-Dimensional Analysis of Thermoelectric Modules (TEMs). *IEEE Transactions on Components and Packaging Technologies* 2005; 28 (2): 218–29.
- [86] Hodes M. Precision temperature control using a thermoelectric module. In: *Heat-Transfer Calculations*. New York, NY, USA: McGraw–Hill, 2006.
- [87] Sofrata H. Solar thermoelectric cooling system. In: *Proceedings of the Fifth SOLARAS Workshop*. Riyadh, Saudi Arabia, 1984, 59–76.
- [88] Astrain D, Martínez A, Gorraiz J, Rodríguez A, Pérez G. Computational study on temperature control systems for thermoelectric refrigerators. *J Electron Mater* 2012;41(6):1081–1090.
- [89] Martínez A, Astrain D, Rodríguez A, Pérez G. Reduction in the electric power consumption of a thermoelectric refrigerator by experimental optimization of the temperature controller. *J Electron Mater* 2013;42(7):1499–1503.
- [90] Astrain D, Vián JG, Domínguez M. Increase of COP in the thermoelectric refrigeration by the optimization of heat dissipation. *Applied Thermal Engineering* 2003; 23 (17): 2183–200.
- [91] Vián JG, Astrain D. Development of a hybrid refrigerator combining thermoelectric and vapor compression technologies. *Applied Thermal Engineering* 2009; 29(16): 3319–27.
- [92] He MG, Li TC, Liu ZG, Zhang Y. Testing of the mixing refrigerants HFC152a/HFC125 in domestic refrigerator. *Applied Thermal Engineering* 2005; 25 (8–9): 1169–81.
- [93] Pilatte A. A Photovoltaic Refrigerator for Storage of Vaccines and Icemaking. *Energy for Rural and Island Communities*,1984; 229–237.
- [94] Toure S, Fassinou WF (1999). Cold storage and autonomy in a three compartments photovoltaic solar refrigerator: experimental and thermodynamic study. *Renewable Energy*, 17: 587–602.
- [95] Zhang P, Liu QS, Wang RZ. Performance and applicability of a DC refrigerator powered by the photovoltaics. *J. Renewable Sustainable Energy* 2010;2:1–8.
- [96] Ekren O, Yilanci A, Cetin H, Ozturk HK. Experimental performance evaluation of a PV powered refrigeration system. *Electronics and Electrical Engineering*. Kaunas: Technologija 2011; 8(114):7–10.
- [97] Aktacir MA. Experimental study of a multi-purpose PV-refrigerator system. *International Journal of Physical Sciences* 2011; 6(4):746–757.
- [98] Xi G, Cai C, Li J, Deng Y, 2013. Experimental study on a solar photovoltaic DC refrigerator. *Journal of Appl Mech Mater* 2013; 316-317:109–112.
- [99] Tina GM, Grasso AD. Remote monitoring system for stand-alone photovoltaic power plants: The case study of a PV-powered outdoor refrigerator. *Energy Conversion and Management* 2014;78:862–71.
- [100] Sidney S, Lal D M. Exergy analysis of a solar PV driven DC refrigerator for different ambient conditions. International Conference on Energy Efficient Technologies for Sustainability (ICEETS) 2016, India.
- [101] Kattakayam TA, Srinivasan K. Thermal performance characterization of a photovoltaic driven domestic refrigerator. *International Journal of Refrigeration* 2000; 23:190–6.
- [102] Modi A, Chaudhuri A, Vijay B, Mathur J, 2009. Performance analysis of a solar photovoltaic operated domestic refrigerator. *Applied Energy* 2009;86:2583–91.
- [103] Gupta BL, Bhatnagar M, Mathur J. Optimum sizing of PV panel, battery capacity and insulation thickness for a photovoltaic operated domestic refrigerator. *Sustain Energy Technol Assessments* 2014;7:55–67.
- [104] Akinola AO, Mogaji TS, Adewole KA. *International Journal of Emerging Technology and Advanced*
- [105] Samar KK, Kothari S, Jindal S. *Solar Refrigeration Model*, *Energética India*, 2015.
- [106] Field RL. Photovoltaic/thermoelectric refrigerator for medicine storage for developing countries. *Solar Energy* 1980; 25:445–7.

- [107] Sofrata H. A Thermo-Electric Refrigerator Powered by Photo-Voltaic Solar Collectors. *Applied Energy* 1984;18:137–142.
- [108] Dai YJ, Wang RZ, Ni L. Experimental investigation on a thermoelectric refrigerator driven by solar cells, *Renewable Energy* 2003a; 28: 949–59.
- [109] Dai Y, Wang J, Ni L. Experimental investigation and analysis on a thermoelectric refrigerator driven by solar cells. *J Solar Energy Mater Solar Cells* 2003b; 77(4): 377–91.
- [110] Abdul-Wahab SA, Elkamel A, Al-Damkhi AM, Al-Habsi IA, Al-Rubaiey HS, Al-Battashi AK, et al.. Design and experimental investigation of portable solar thermoelectric refrigerator. *Renew. Energy* 2009; 34:30–4.
- [111] Min G, Rowe DM. Experimental evaluation of prototype thermoelectric domestic-refrigerators. *Applied Energy* 2006; 83 (2), 133–52.
- [112] Saidur R, Masjuki HH, Hasanuzzaman M, Mahlia TMI, Tan CY, Ooi JK, Yoon PH. Performance investigation of a solar powered thermoelectric refrigerator. *International Journal of Mechanical and Materials Engineering* 2008; 3(1):7–16.
- [113] Vián JG, Astrain D. Development of a thermoelectric refrigerator with two phase thermosyphons and capillary lift. *Applied Thermal Engineering* 2009a; 29:1935–40.
- [114] Lasseter RH. Microgrids. In *Proc. IEEE Power Engineering Society Winter Meeting* 2002;146–9.
- [115] DOE. Microgrid Exchange Group. 2011. DOE Microgrid Workshop Report. (online: <http://energy.gov/oe/downloads/microgrid-workshop-report-august-2011>).
- [116] Zhang H, Baeyens J, Cáceres G, Degrève J, Lv Y. Thermal energy storage: Recent developments and practical aspects. *Progress in Energy and Combustion Science* 2016; 53:1–40.
- [117] Justo JJ, Mwasilu F, Lee J, Jung JW. AC–microgrids versus DC–microgrids with distributed energy resources: A review. *Renewable and Sustainable Energy Reviews* 2013; 24: 387–405.
- [118] Basak P, Chowdhury S, Haldernee Dey S, Chowdhury SP. A literature review on integration of distributed energy resources in the perspective of control, protection and stability of microgrid. *Renewable and Sustainable Energy Reviews* 2012; 16: 5545–56.
- [119] Sharp F, Symanski D, Dudzinski MS. Scalable DC Micro Grids provide cost effective electricity in regions without electric infrastructure. In: *Proceedings of 2014 the Global Humanitarian Technology Conference* 2014; 18–24.
- [120] Franceschi J, Rothkopf J, Miller G. Off-grid solar PV power for humanitarian action: from emergency communications to refugee camp micro-grids. *Procedia Engineering* 2014; 78: 229 – 35.
- [121] Bhattacharyya SC. Mini-grid based electrification in Bangladesh: technical configuration and business analysis. *Renewable Energy* 2015; 75:745–61.
- [122] Rosa J, Madduri PA, Soto D. Efficient Microgrid Management System for Electricity Distribution in Emerging Regions. *Global Humanitarian Technology Conference* 2012; 23–26.
- [123] Spertino F, Ahmad J, Ciocia A, Di Leo P. Techniques and Experimental Results for Performance Analysis of Photovoltaic Modules Installed in Buildings. In: *The 8th International Conference on Sustainability in Energy and Buildings*, Turin, 2016; 11–13.
- [124] Spertino F, Di Leo P, Cocina V, Tina GM. Storage sizing procedure and experimental verification of stand-alone photovoltaic systems. 2012 IEEE International Energy Conference and Exhibition, ENERGYCON 2012, art. no. 6348199, 2012; 464–468.
- [125] JRC European Commission, PVgis photovoltaic calculator for Europe, web site <http://re.jrc.ec.europa.eu/pvgis/apps4/pvest.php?lang=en&map=europe> (accessed 30 September 2016).
- [126] Spertino F, Chicco G, Ciocia A, Di Leo P. Matching between Electric Generation and Load: Hybrid PV-Wind System and Tertiary-Sector Users. *Power Engineering Conference (UPEC), 50th International Universities*, Stoke on Trent, UK 2015; 1–6.
- [127] Spertino F, Ciocia A, Cocina V, Di Leo P. Renewable sources with storage for cost-effective solutions to supply commercial loads. *International Symposium on Power Electronics, Electrical Drives, Automation and Motion (SPEEDAM)*, Anacapri, Italy 2016; 242–47.