

Inertial measurement system for swimming rehabilitation

Original

Inertial measurement system for swimming rehabilitation / Parvis, Marco; Corbellini, Simone; Lombardo, Luca; Iannucci, Leonardo; Grassini, Sabrina; Angelini, Emma. - ELETTRONICO. - 1:(2017), pp. 361-366. (12th IEEE International Symposium on Medical Measurements and Applications, MeMeA 2017 usa 2017) [10.1109/MeMeA.2017.7985903].

Availability:

This version is available at: 11583/2680438 since: 2020-02-17T11:02:40Z

Publisher:

Institute of Electrical and Electronics Engineers Inc.

Published

DOI:10.1109/MeMeA.2017.7985903

Terms of use:

This article is made available under terms and conditions as specified in the corresponding bibliographic description in the repository

Publisher copyright

IEEE postprint/Author's Accepted Manuscript

©2017 IEEE. Personal use of this material is permitted. Permission from IEEE must be obtained for all other uses, in any current or future media, including reprinting/republishing this material for advertising or promotional purposes, creating new collecting works, for resale or lists, or reuse of any copyrighted component of this work in other works.

(Article begins on next page)

© 2017 IEEE. Personal use of this material is permitted. Permission from IEEE must be obtained for all other uses, in any current or future media, including reprinting/republishing this material for advertising or promotional purposes, creating new collective works, for resale or redistribution to servers or lists, or reuse of any copyrighted component of this work in other works.

Title: Inertial measurement system for swimming rehabilitation

Authors:

Marco Parvis

Dept. of Electronics and Telecommunications, Politecnico di Torino, Torino, Italy

Simone Corbellini

Dept. of Electronics and Telecommunications, Politecnico di Torino, Torino, Italy

Luca Lombardo

Dept. of Electronics and Telecommunications, Politecnico di Torino, Torino, Italy

Leonardo Iannucci

Dept. of Electronics and Telecommunications, Politecnico di Torino, Torino, Italy

Sabrina Grassini

Dipartimento di Scienza Applicata e Tecnologia, Politecnico di Torino, Torino, Italy

Emma Angelini

Dipartimento di Scienza Applicata e Tecnologia, Politecnico di Torino, Torino, Italy

DOI: 10.1109/MeMeA.2017.7985903

Inertial measurement system for swimming rehabilitation

Sabrina Grassini, *Member, IEEE*, Marco Parvis, *Fellow, IEEE*, Emma Angelini, Luca Lombardo, and Leonardo Iannucci

Abstract— *The occurrence of light spinal diseases due to the low physical activity of daily life is continuously increasing. Recovering from these diseases requires specific and directed physical activity and can conveniently be performed in swimming pools where the apparent weight reduction due to the water helps letting patients perform the relief movements. Unfortunately a way for easily assessing the correctness of the patient's movement is still missing and in most cases everything relies on the capabilities of the trainers, which must be continuously present. This paper describes an attempt to arrange a simple system suitable for a quasi on-line self assessing to the movement correctness. The proposed system is based on two inertial assemblies to be worn on the wrists and capable of sending data to a receiver installed at pool border. Data received from these small assemblies are processed to show the patients the symmetry of their movements, which is connected to the movement efficiency. The inertial assemblies are arranged by using a commercial miniaturized Inertial Measurement Unit, a Teensyduino board, and a μ Panel WiFi transmitter which is able to send the data to the receiver during the swimming. The receiver processes the data in-line so that, when the patients stop swimming to take a rest, they can be displayed to the patients as a self-assess of the just performed activity.*

I. INTRODUCTION

Non competitive swimming activities are recognized to be important tools for rehabilitation [1] useful also in the case of light spinal diseases i.e. where measuring the capability of patients to perform a symmetric swimming can be an indicator of disease regression. Nowadays an extensive work has been deployed to assess the swimming style, but in most cases the work is oriented toward increasing the athletes' performance [2] [3] [4] in competitions, while the swimming assessment for rehabilitation is usually left to certified trainers.

However, the same typology of sensors used for increasing the performance of competitive swimmers can be in principle used also for revealing abnormal movements due to spinal diseases. In fact, spinal diseases are often associated to asymmetries in the swimming [5], [6], so that a simple wearable system suitable for working during swimming and capable of revealing the movement asymmetry would be interesting for both diagnosis and for helping patients during their rehabilitation.

Patients in most cases do not have the capability of "feeling the water", so that they are not able to correct their body position and orientation without external help.

Different solutions can be used to assess the swimmer movement, but most of them can be grouped into two main

S. Grassini and E. Angelini are with the Department of Applied Science and Technology, Politecnico di Torino, Italy,

S. Corbellini, L. Iannucci, L. Lombardo and M. Parvis are with Department of Electronics and Telecommunications, Politecnico di Torino, Italy.

categories: movement video recording and inertial sensors assessment. The first group is usually rather expensive and requires manual judgement of the movement by a certified observer, while the second group can lead to low cost systems, even though with several problems related to the water presence. Specifically, since water strongly impairs radio-wave propagation [7], in most cases data processing from inertial sensor assemblies has to be performed off-line [8] and this limits the system feasibility.

In this paper the authors propose a low cost solution which is both designed to assess the swimmer movement and to deliver data in quasi-real-time avoiding the delay connected to the off line process. The proposed system employs two measuring units to be strapped to the wrists and that transmit data to a receiver located at swimming pool border.

II. WIRELESS SENSOR DESIGN

The proposed sensor assembly is based on the combination of an inertial management units (IMU), a microcontroller and a wireless transmitter according to the block diagram shown in fig. 1.

Since the assembly must be worn by patients during their swimming activity, it has to be designed in order to limit its impact on the swimming. Specifically:

- The assembly size has to be small compared to the arms to limit its effect on the arm movements. This requires sensor assemblies with size not exceeding few centimetres.
- The assembly has to be designed in order to avoid adding solicitations during the swimming. The effect of the

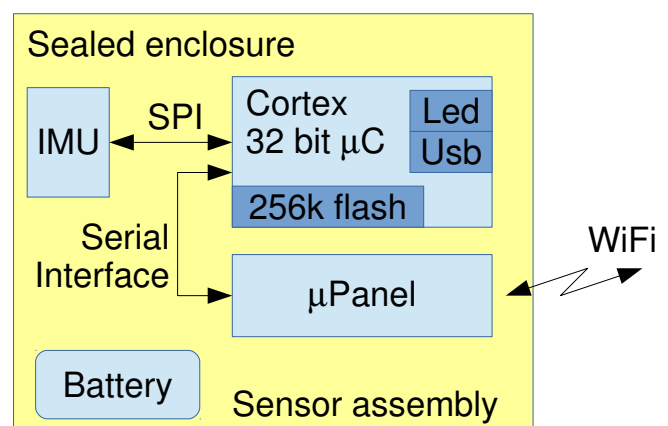

Fig. 1. Block diagram of the proposed sensor assembly.

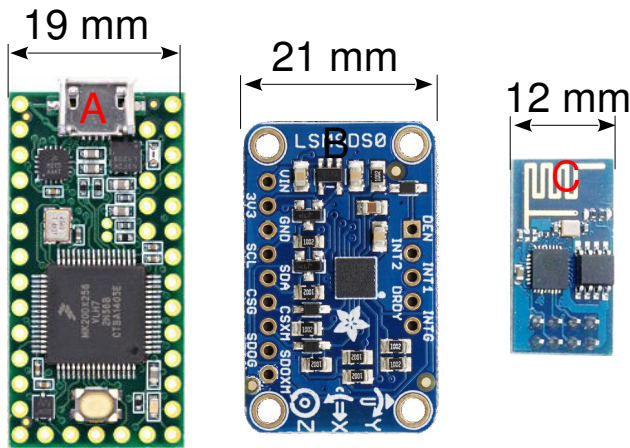

Fig. 2. The commercial components employed to arrange the sensing assembly. From the left A) Teensyduino microcontroller, B) IMU with nine sensors, C) μ Panel wireless transmitter.

assembly presence on the wrists is mainly due to the increased friction with respect to the water and to the and to the assembly weight. The first effect is minimized by a small size, while the second is connected to the assembly density and is minimized by an apparent density of about 1 kg/dm^3 , so that the Archimedes force is made negligible.

- The assembly must be able to work without external cabling, i.e. has to be battery operated and capable of transmit data to a receiver through a wireless link.

All constraints can be satisfied taking by advantage of solid state sensors used to arrange the IMU component [9]. Such components are widely employed in several commercial devices like smart phones and have an extremely limited cost. Solid state MEMS containing three accelerometers, three gyros and three magnetometers can be found with dimensions as low as $3 \times 3.5 \text{ mm}$.

The use of these sensors would allow one to arrange extremely light assemblies even though at the expense of designing a complex printed circuit board. The authors therefore decided to use small commercial boards easily available off the shelf to arrange a small assembly and test the feasibility of the proposed solution.

Fig. 2 shows the three boards used to arrange the entire assembly which contains:

- A A Teensyduino microcontroller board, which is used as the interface between the sensor assembly and the wireless connection board. The Teensyduino is based on a Cortex M4 chip type MK20DX256VLH7, which is a 32 bit micro-controller equipped with 64 kbytes of RAM and 256 kbytes of flash memory. This board can be programmed in the Arduino environment and contains, *I2C* and *SPI* and serial interface capabilities, which are required to interface with the sensor assembly and the wireless board. This board has a power consumption of about 35 mA plus the current required to drive any external load. The board is equipped with an USB port, which is used program the microcontroller by using the

Arduino environment [10]. The same USB can also be used to transfer data to a PC [8], even though this requires a physical connection with the PC.

- B A board with an LSM9DS0 chip, usually referred to as INemo, that contains three magnetometers, three accelerometers, and three gyros. The sensors are conditioned, converted and let the user to read their digital values. The board contains a digital both *I2C* and *SPI* interfaces. In this project the authors decided to employ the *SPI* interface to communicate with the microcontroller since it allows for a higher data transfer rate with a clock of up to 10 MHz. The LSM9DS0 accelerometers can be programmed to have acceleration full range of about 20, 40, 60, 80, 160 m/s^2 , the angular velocity sensors can be programmed to have full range of about 4.2, 8.7, 35 rad/s . The LMS90D can be programmed to work with sampling frequencies of up to 800 Hz. The power consumption is of about 7 mA

- C A μ Panel wireless connection board. This board [11] contains a complete solution for interfacing a measurement systems to either a smart-phone or to a network and embeds a serial interface which is used to exchange data with the microcontroller. The baud rate for this interface is set at 115200 bit/s, which allows transferring data at more than 10 kByte/s. The μ Panel board contains a flash memory which is organized as a file system and that can store about 160 kBytes of data. The power consumption depends on the conditions of the radio transmitter and can reach 150 mA in the worst case.

The entire system therefore, requires a supply current which is of less than 200 mA. Such value reduces to less than 50 mA when the WiFi radio is turned off.

All the components required to create the sensor assembly are allocated inside a container suitable to be sealed and worn on the wrists. Fig. 3 shows an example of the sensor assembly. The picture shows on the left the box, which contains all the components and which is realized by using a 3D printer, along with the layout of the components. The box is arranged in ABS cured with acetone vapours in order to make it not permeable to the water.

The box is closed by a cap also realized by the 3D printer which also contains the component to power the system. Fig. 3 shows, on the right, a section which highlights the different components. The microcontroller and the IMU are allocated vertically, while the μ Panel board is allocated horizontally on the top of the box. A rechargeable Ni-Cd battery is used to power all components. The battery is connected to the components through a reed relé allocated on the top of the box.

The magnet that activates the reed relé is inserted into the cap: when the cap is closed with the magnet on the relé side, it activate the power and the system starts working. If the cap is inserted with the magnet on the other side nothing happens: this permits to close the sensor ready to work without draining power from the battery. The battery has a capacity 150 mAh. When fully charged the battery can provide about 40 min of continuous use. The working period can be extended to about

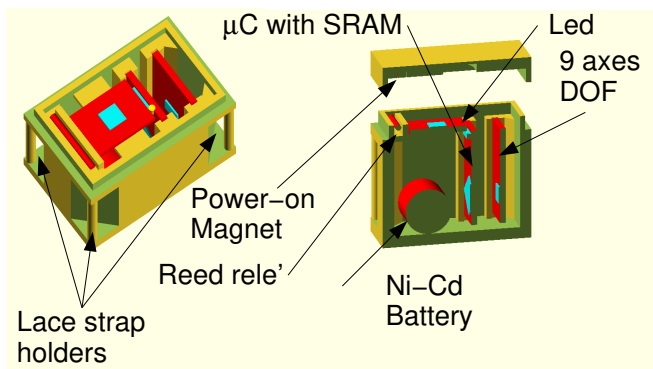

Fig. 3. The sensor assembly: the sealed box which contains the IMU, the Teensyduino microcontroller, the μ Panel wireless board, the power on reed relé and the magnet, the NiCd battery and the led for the user feedback.

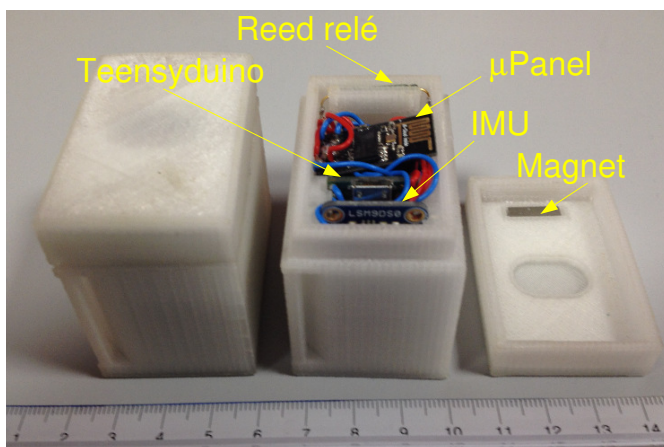

Fig. 4. An example of two assemblies arranged by using a 3D printer.

three hours if the WiFi board is turned off, i.e. at the expense of loosing the real time connection.

The box has a dimension of about $52 \times 32 \times 48$ mm, a volume of about 80 cm^3 including the cap, and a weight of about 65 g. The apparent box density is therefore of about 0.8 kg/dm^3 , a value slightly lower than the water density. This insures the box floats in case it gets detached from the wrist, but also insures not applying large Archimedes' force the swimmer.

A led is connected on the top of the microcontroller and turns on when the system is measuring to give a feedback to the user. The cap is arranged with a lower thickness in correspondence to the led to let the light be visible from outside.

Fig. 4 shows an example of sensor assembly. The right part of the picture shows the box opened and let seeing the main components, i.e. the μ Panel board, the IMU, the Teensyduino the relé and the magnet. The battery is located below the μ Panel board and cannot be seen.

III. SENSOR SET-UP AND CALIBRATION

In order to use the sensors, three steps have to be carried out, i.e. the selection of the measuring range, the selection

of the sampling frequency and the correction of the sensor misalignments to refer to the same orthonormal reference system.

As told in the previous section, the sensing part of the proposed system is composed by the LSM9DS0 which can be programmed to have different measuring ranges. Some preliminary tests performed on normal swimmers [8] permitted to define the expected measuring ranges. After these tests the accelerometers were programmed for a measuring range of about $\pm 40 \text{ m/s}^2$ (i. e. $\pm 4 \text{ g}$), which permitted to avoid saturation. The gyrometers were programmed to work with a range of about $\pm 35 \text{ rad/s}$ (i.e. $\pm 2000 \text{ dps}$), while the magnetic sensors were set at their maximum sensitivity, i.e. $200 \mu\text{T}$.

The LSM9DS0 can be programmed to sample data up to about 800 Hz, but the SPI channel coupled with the Teensyduino is capable of transferring data at a maximum speed of about 2 kSample/s. When all the nine values coming from the sensors need to be transferred this turns out in a limitation of the transfer rate of about 200 Hz. Some preliminary tests [8] highlighted that the typical swimming has fundamental frequencies of the order of 0.2 – 0.3 Hz, which correspond to strokes every 3 – 5 s, with an energy contents that falls below 1% of the maximum value at about 10 Hz and becomes negligible at about 20 Hz. Sampling at 40 Hz therefore lets to capture all the information on the swimming. For these reason the authors decided to sample data at 200 Hz and to apply a finite impulse response low-pass filter of five samples on the data, storing them on 40 Hz. This way the data stream coming from the nine sensors, which uses two bytes for each measurement, is of below 800 bytes/s. This value can be easily transferred through the 115200 bit/s serial line and provide space for about 200 s of measurement in the μ Panel memory. Such data are also meant to be sent to the WiFi network in real time, but storing them locally let to avoid loosing data also in the case the WiFi link stops working for any reason. The samples can also be stored the local Teensyduino memory to be transferred to the PC via USB if the WiFi cannot be used for any reason.

The third step before using the system is the calibration of the sensitivity axes to remove the effect of the misalignment and to correct for gain errors which are stated fro the LMS9DS0 to be of 1.5% for the accelerometers and of about 3% for the gyrometers.

The calibration of sensitivity and alignment of the accelerometers can be performed remembering that all accelerometers are affected also by the local gravity, which is stable and vertical. The calibration can therefore be performed by acquiring the output of the accelerometers in steady conditions, where the only present acceleration the local gravity, while rotating the sensor in different positions [8], [12]. Using the symbols already employed in [8], the corrected estimated acceleration $\hat{\mathbf{A}}$ can be expressed as:

$$\hat{\mathbf{A}} = \mathbf{R}_a \cdot \mathbf{K}_a \cdot (\mathbf{A} - \mathbf{A}_b) \quad (1)$$

where \mathbf{A} is the (column) vector of the accelerations as obtained by using the nominal sensitivity values, \mathbf{A}_b is the

(column) vector of the bias of the three accelerometers, \mathbf{K}_a is the 3×3 diagonal matrix containing the sensitivity correction coefficients, and \mathbf{R}_a is the 3×3 matrix, which takes the cross-axis effects into accounts.

\mathbf{R}_a is a matrix whose coefficients are:

$$\hat{\mathbf{R}}_a = \begin{bmatrix} 1 & j_{a-xy} & k_{a-xz} \\ 0 & 1 & k_{a-yz} \\ 0 & 0 & 1 \end{bmatrix} \quad (2)$$

where j_{a-xy} , k_{a-xz} , k_{a-yz} are the projection coefficients and the x axis is assumed to be the actual sensitivity axis of the x accelerometer.

A similar equation can be used to estimate the angular velocity $\hat{\omega}$:

$$\hat{\omega} = \mathbf{R}_g \cdot \mathbf{K}_g \cdot (\omega - \omega_b) \quad (3)$$

where again ω is the (column) vector of the angular velocities computed according to the nominal sensitivity values, ω_b is the (column) vector of the bias of the three gyros, \mathbf{K}_g is the 3×3 diagonal matrix containing the sensitivity correction coefficients, and \mathbf{R}_g is the 3×3 matrix which takes the cross-axis effects into accounts.

In this case it is necessary to assume the all the three gyrometers have sensitivity axis defined with respect to the accelerometer unit vectors, therefore \mathbf{R}_g does not have zero coefficients:

$$\hat{\mathbf{R}}_g = \begin{bmatrix} 1 & j_{g-xy} & k_{g-xz} \\ i_{g-yx} & 1 & k_{g-yz} \\ i_{g-zx} & j_{g-zy} & 1 \end{bmatrix} \quad (4)$$

All the unknown coefficients (9 parameters regarding eqn. 2, i.e. 3 bias values, 3 sensitivity correction coefficients and 3 cross-sensitivity coefficients and 12 coefficients regarding eqn. 3) can be estimated by using the procedure described in [8].

As an example, in the case of the LMS90DS0, the calibration reduces the residual standard deviation on the accelerometers of more than five times and down to about 3% of the full range. Most of this reduction is due to the bias estimation while the gain is usually correct within $\pm 1\%$ and the alignment is within $\pm 1^\circ$.

After the calibration, the most critical problems remain the sensor drifts, which prevent using them to arrange a real strap-down platform working for more than few seconds.

IV. SWIMMING ASSESSMENT

Several approaches have been followed to assess the swimming by using IMU based devices. In several cases data coming from the IMU have been employed to follow the actual swimmer movement [2],[3]. This approach is the most powerful as it can provide a complete set of information regarding the swimmer, but its use is problematic due to the inherent uncertainties and drifts connected to the solid state sensors contained in low-cost IMUs and requires sophisticate corrections, which relies on the overall swimmer movement (e.g. the swim level, the swim trajectory,...). Of course, assessing the swimming symmetry does not require one to follow the complete swim trajectory, so some authors started

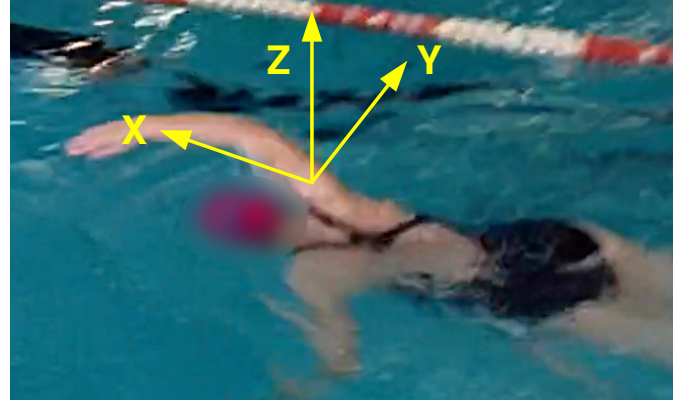

Fig. 5. Movement during front crawl.

to develop algorithms which are based on a single category of sensors. As an example in [5], the accelerometers have been used based on the idea that the asymmetry is connected to different arm movement accelerations.

The author of this paper instead proposes to employ the angular velocity recorded at wrist level as the main indicator. The idea, shown in fig. 5, is that during front crawl the arms perform a rotation around an axis orthogonal to the body and have a antisymmetric angular velocity of the two arms with respect to the other axes; any alteration of this antisymmetry can be regarded as a swimming asymmetry due to a physical problem.

The processing would be easy if the angular velocity sensors were oriented to have one axis orthogonal to the body movement, however this is not the way the data are obtained due to both the movements and the approximated mounting of the sensor assembly on the wrists.

Fortunately, it is possible to derive a simple solution at least for the purpose of movement symmetry assessment. During a single front crawl run, the swimmer is forced to follow an approximately straight line so that, on the average, the arms rotates only in a direction orthogonal to the body. Making reference to fig. 5 this means that the only angular velocity that should positively integrate to an increasing angle is related to the y axis.

The authors therefore computed a the rotation matrix \mathbf{R}_o that minimize the average values of ω_x and ω_z over an interval equals to a single run, before the swimmer turns to swim back.

$$\omega_R = \mathbf{R}_o \cdot \omega \quad (5)$$

where ω is the vector of the acquired samples.

It is important to observe that this rotation matrix makes the sample appearing like having a different initial orientation of the IMU, but without altering the acquired values in any other way so that the acquired data are not corrupted in any way. The result after this rotation is in the form shown in fig. 6. The traces of x and z have a negligible mean value, while the average value is positive only for the y component.

The initial rotation is also useful to compare the traces from right and left arms. Fig. 7 shows the traces of right and left arms superposed after the rotation described before

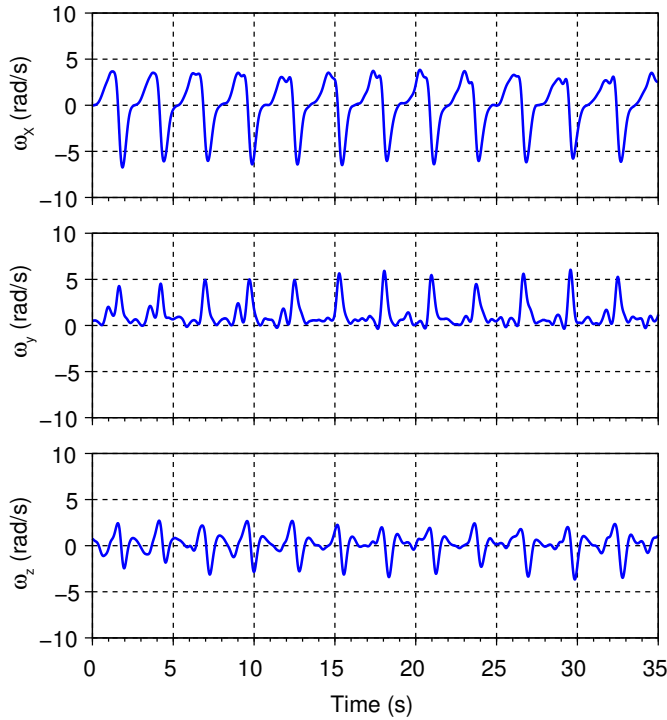

Fig. 6. Angular velocity traces after the rotation to minimize the cumulative angle on x and z axes.

and recorded with a patient having a light spinal disease due to a vertebral protusion. In the figure, the traces regarding x and z of the left arm have been reversed to highlight the antisymmetry of the movements in these directions.

It is easy to observe how the y components of the two arms are similar, as the arm rotation corresponds to one full angle per stroke, while the x and z' components are rather similar after the sign reversal on one of them. This confirms the antisymmetry, but also highlights some shape differences that repeat at every stroke.

Looking at traces of fig. 7 it is natural to observe that the traces are neither perfectly periodic nor perfectly aligned in the two arms, as the swimmer continuously changes its swimming pace and does not keep it constant. This prevents directly using the traces for the processing by comparing right and left angular velocity. An idea to get rid of the varying pace is to use a processing on the three angular components of each arm within each stroke. This processing should highlight different types of movements of the two arms and therefore symmetry problems, but requires identifying the strokes.

Fortunately, once the angular velocity components have been rotated as described, it is easy to identify the single strokes, by looking at the local maxima of the y component. Fig 8 shows an example of swimming performed on a short (25 m) swimming pool. It is easy to observe the three swim inversion at the end of the swimming pool.

At this point each stroke can be isolated and it is possible to compute for each stroke the cross-correlation of the three angular velocity components:

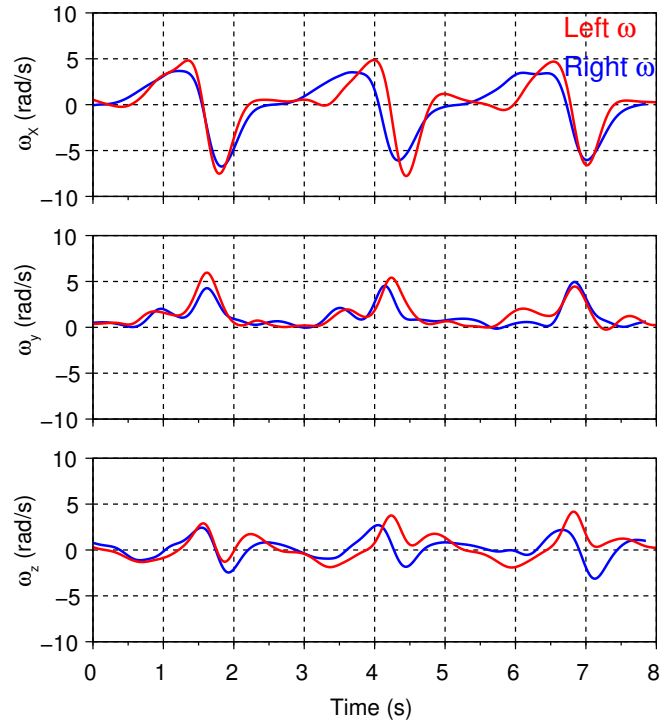

Fig. 7. Comparison of right and left arm angular velocity. The x and z components of the right trace have been reversed to highlight the antisymmetry.

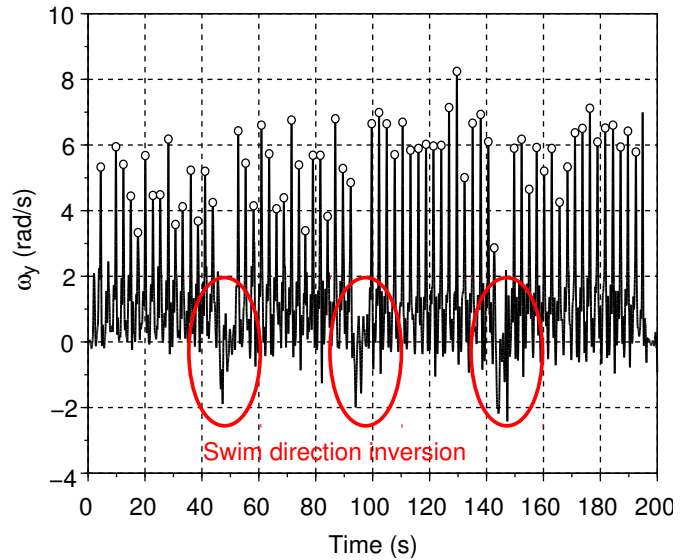

Fig. 8. Strokes as identified on the y angular velocity component

$$C_{k-ij} = \sum_{\nu=0}^{n-k} \omega_i(\nu+k)\omega(\nu) \quad (6)$$

where C_{k-ij} denotes the cross correlation coefficients between two axes ($ij = XY, YZ, XZ$), ω_i denotes the i angular velocity, and k denotes the sample number within each stroke.

Since the strokes happens with different durations and speed, in order to compare them it is useful to normalize the values. This can be easily done by referring to the norm of

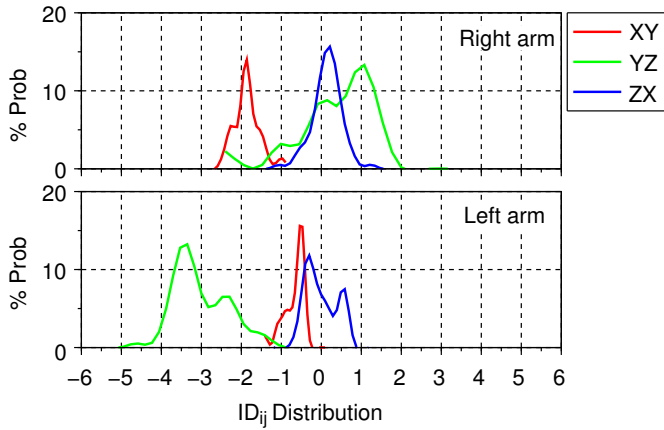

Fig. 9. Distribution of ID_{ij} for right and left arms.

the angular velocities therefore defining a stroke ID triplet for each stroke and arm

$$ID_{ij} = \frac{\sum_k C_{ij}(k)t(k)}{\|\omega_i\| \cdot \|\omega_j\|} \quad (7)$$

where C_{ij} denotes the cross correlation between two axes ($ij = XY, YZ, XZ$), $\|\omega_i\|$ denotes the norm of the angular velocity, and k denotes the sample number within each stroke.

By applying eqn. 7 to all identified strokes in a run it is possible to identify a distribution of the indexes as shown in fig. 9 where a swimming run with more than sixty strokes has been analysed. The figure clearly shows how the correlations that involve the main angular velocity (i.e. XY and YZ) show a remarkable position difference between the two arms.

V. CONCLUSIONS

This paper describes design and use of simple and low-cost IMU based systems to be used in swimming rehabilitation. The proposed set-up is based on two small sensor assemblies having size $3 \times 5 \times 5$ cm to be worn on the wrists during swimming.

Each assembly is powered by a battery and is equipped with a WiFi module that permits sending acquired data to a

The overall assembly cost is of less than 100 \$ per unit thus enabling the possibility of a mass use of the proposed approach.

receiver located at swimming pool border in real time. The WiFi module does not work under water, but is capable of sending data during the periods the arm is outside the water.

The system can be used for more than 40 min after a full battery recharge. The processing is based on the stroke identification based on the angular velocity and on the estimation of an index based on the cross correlation of the angular velocity components during each stroke.

Tests performed with a patient suffering from backache undergoing rehabilitation by swimming highlighted how the system is clearly capable of highlighting the asymmetry of the arm movements. Other tests are being carried out to correlate the index differences with the problems experienced by the patients.

REFERENCES

- [1] Becker, B. E. *Aquatic Therapy: Scientific Foundations and Clinical Rehabilitation Applications* PM&R American Academy of Physical Medicine and Rehabilitation, vol. 1, pp. 859-972, 2009 available at [http://www.pmrjournal.org/article/S1934-1482\(09\)00551-6/pdf](http://www.pmrjournal.org/article/S1934-1482(09)00551-6/pdf)
- [2] Dadashi, F.; Crettenand, F.; Millet, G. P.; Aminian, K. *Front-Crawl Instantaneous Velocity Estimation Using a Wearable Inertial Measurement Unit Sensors*, vol. 12, pp. 12927-12939, 2012
- [3] Dadashi, F.; Millet, G. P.; Aminian, K. *Inertial measurement unit and biomechanical analysis of swimming: an update* available at: <http://infoscience.epfl.ch/record/189819/files/Sportmedizin%20-%20Dadashi%20et%20al-%202013.pdf>
- [4] Bäcklin, M.; Tröster, G. *Swimming performance and technique evaluation with wearable acceleration sensors Pervasive and Mobile Computing*, vol. 8, pp. 68-81, 2012
- [5] R.H. Sanders; J. Thow; M. Fairweather, *M Asymmetries in swimming: Where do they come from Journal of Swimming Science*, no. 18, 2011
- [6] Stamm, A.; James, D. A.; Hagem, R., M.; Thiel, V., D. *Investigating arm symmetry in swimming using inertial sensors Sensors 2012*, vol. 1, pp. 1 - 4, 2012
- [7] S. Sendra; J. V. Lamparero; J. Lloret; M. Ardid *Underwater Communications in Wireless Sensor Networks using WLAN at 2.4GHz* Eight IEEE International Conference on Mobile Ad-Hoc and Sensor Systems, MASS 2011, Valencia Oct. 17-22, 2011, pp. 892-897
- [8] Parvis, M.; Grassini, S.; Angelini, E.; Scattareggia, S. *Swimming symmetry assessment via multiple inertial measurements MeMeA 2016*, vol. 1, pp. 1 - 6, 2016
- [9] Zihajehzadeh, S.; Yoon, P.K.; Bong-Soo Kang; Park, E.J. *UWB-Aided Inertial Motion Capture for Lower Body 3-D Dynamic Activity and Trajectory Tracking IEEE Tr. on Instrumentation and Measurement*, vol. 64, no. 2, pp. 3577-3587, 2015
- [10] *Arduino software & hardware* available at <https://www.arduino.cc> last checked 2016-12-25
- [11] *μ Panel* available at <http://www.miupanel.com>, last checked on 2016-12-25
- [12] Nilsson, J.-O.; Skog, I.; Handel, P. *Aligning the Forces — Eliminating the Misalignments in IMU Arrays IEEE Tr. on Instrumentation and Measurement*, vol. 63, no. 10, pp. 2498-2500, 2014