

Damaged composite laminates Assessment of residual Young's modulus through the Impulse Excitation Techniq

Original

Damaged composite laminates Assessment of residual Young's modulus through the Impulse Excitation Techniq / Paolino, Davide Salvatore; Geng, Hanze; Scattina, Alessandro; Tridello, Andrea; Cavatorta, Maria Pia; Belingardi, Giovanni. - In: COMPOSITES. PART B, ENGINEERING. - ISSN 1359-8368. - ELETTRONICO. - 128:(2017), pp. 76-82. [10.1016/j.compositesb.2017.07.008]

Availability:

This version is available at: 11583/2676191 since: 2017-07-17T14:18:25Z

Publisher:

Elsevier

Published

DOI:10.1016/j.compositesb.2017.07.008

Terms of use:

This article is made available under terms and conditions as specified in the corresponding bibliographic description in the repository

Publisher copyright

Elsevier postprint/Author's Accepted Manuscript

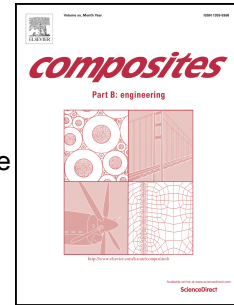
© 2017. This manuscript version is made available under the CC-BY-NC-ND 4.0 license
<http://creativecommons.org/licenses/by-nc-nd/4.0/>. The final authenticated version is available online at:
<http://dx.doi.org/10.1016/j.compositesb.2017.07.008>

(Article begins on next page)

Accepted Manuscript

Damaged composite laminates: Assessment of residual Young's modulus through the Impulse Excitation Technique

Davide S. Paolino, Hanze Geng, Alessandro Scattina, Andrea Tridello, Maria Pia Cavatorta, Giovanni Belingardi



PII: S1359-8368(17)30112-9

DOI: [10.1016/j.compositesb.2017.07.008](https://doi.org/10.1016/j.compositesb.2017.07.008)

Reference: JCOMB 5143

To appear in: *Composites Part B*

Received Date: 11 January 2017

Revised Date: 26 May 2017

Accepted Date: 2 July 2017

Please cite this article as: Paolino DS, Geng H, Scattina A, Tridello A, Cavatorta MP, Belingardi G, Damaged composite laminates: Assessment of residual Young's modulus through the Impulse Excitation Technique, *Composites Part B* (2017), doi: 10.1016/j.compositesb.2017.07.008.

This is a PDF file of an unedited manuscript that has been accepted for publication. As a service to our customers we are providing this early version of the manuscript. The manuscript will undergo copyediting, typesetting, and review of the resulting proof before it is published in its final form. Please note that during the production process errors may be discovered which could affect the content, and all legal disclaimers that apply to the journal pertain.

Damaged composite laminates: Assessment of residual Young's modulus through the Impulse Excitation Technique

Davide S. Paolino*, Hanze Geng, Alessandro Scattina, Andrea Tridello, Maria Pia Cavatorta, Giovanni Belingardi

Politecnico di Torino, Department of Mechanical and Aerospace Engineering,
Corso Duca degli Abruzzi 24, 10129 Torino, Italy

***Corresponding Author**

Phone: +39 011 0905746

Fax: +39 011 0906999

Email: davide.paolino@polito.it

Abstract

The objective of this study is to evaluate the capability of the Impulse Excitation Technique (IET) in assessing the residual elastic properties of damaged composite laminates. To this aim, the Young's modulus in the longitudinal direction of undamaged and damaged thick laminates is evaluated both with the IET and with a tensile test, according to the ASTM standard. The differences between the reference ASTM values and the IET values are then interpreted through a simple mechanical model of the damaged laminate. Potentialities and weaknesses in the application of the IET for the assessment of the residual elastic properties are finally discussed and highlighted in the paper.

Keywords: Impulse Excitation Technique (IET), residual elastic properties, damaged laminates

1. Introduction

In the last decades, the diffusion of composite materials has significantly increased in a wide range of industrial applications. The high specific strength and stiffness, as well as the wide flexibility in shaping and designing, make composite materials the most appropriate alternative to traditional metallic materials for many machinery components. However, failure in composite materials may be due to different and interacting failure modes, which can hardly be predicted and monitored. Damage complexity thus represents one of the main limitations to the diffusion of composite materials in many industrial applications. A reliable but simplified damage assessment procedure would allow a larger diffusion of composites.

At present, non-destructive tests (NDTs) are widely adopted for the assessment of damage extension in composite components and structures [1-11]. NDT is generally performed for the quality assessment, during the production process, or for the structural integrity assessment, during the in-service life. After any damaging event, NDT could be effectively used for the selection of the optimal maintenance strategy. A decision as to carry out a specific reparation or a complete replacement depends on the residual structural capability of the damaged component to perform its mission. The NDT could provide the required pieces of information for taking the final decision. In particular, NDT, resulting in a quantitative assessment of the residual local properties of the damaged component may provide the necessary input for the correct mission simulation and the simulation results address the proper maintenance strategy. However, as reported in [1], the current applications of NDTs provide useful information on internal defects (either generated during the manufacturing process or after a damaging event) but do not permit a direct assessment of the residual properties. In this study, preliminary steps are made towards a simplified NDT for the quantitative evaluation of the residual elastic properties of damaged laminates and results are compared to traditional tensile tests.

The Impulse Excitation Technique (IET) is adopted for the application of the simplified NDT. In the literature, the IET is generally employed for measuring the elastic properties of isotropic metallic [12-15] and ceramic [16-18] materials according to the ASTM standards [19-20]; whereas, it is rarely applied for measuring the elastic properties of orthotropic composite materials [21-23]. To the Authors' best knowledge, the IET has never been applied to damaged composite laminates. The aim of the present study is to evaluate potentialities and weaknesses in the application of the IET for measuring the residual elastic properties of damaged composite laminates.

2. Materials and Methods

To evaluate the capability of the IET in the measurement of the residual elastic properties of damaged composites, a series of experimental tests are carried out on a structural composite laminate for automotive applications.

2.1. Material

The experimental tests are performed on composite laminates made of epoxy resin (E720) reinforced with eight twill 2x2 fabrics made of carbon fibre (T700). The nominal laminate thickness is 6.7 mm.

Angle-Ply specimens (referred to as AP specimens, in the following) with stacking sequence $[\pm 45]_8$ and Cross-Ply specimens (referred to as CP specimens, in the following) with stacking sequence $[0/90]_8$ are investigated in this study. Two different constant rectangular cross sections are used for the AP and CP specimens, according to the recommendations of the ASTM standard for tensile testing of composite laminates [24]: AP specimens are $12.7 \text{ mm} \times 150 \text{ mm}$; whereas CP specimens are $20 \text{ mm} \times 250 \text{ mm}$. Neither tabs nor surface treatments are applied on the specimens.

The same specimen geometries are adopted for performing both IET and standard tensile tests on undamaged and damaged composite laminates.

Four AP specimens and four CP specimens are investigated in undamaged and damaged conditions. The damage is introduced by manually applying ten impulsive loads, on each specimen clamped in a cantilever configuration, through a 4.235 kg rubber hammer with diameter 34 mm, until a visible crack can be found on the surface.

2.2. Experimental tests

A series of experimental tests are carried out to evaluate the base elastic properties of the undamaged specimens and the residual elastic properties of the damaged specimens. IET and tensile tests are performed according to the ASTM standards [20, 24, 25]. Tensile tests are run on a universal hydraulic testing machine, Instron 8801, equipped with a 100 kN load cell. Specimens are tensile-tested in the elastic region, without introducing any permanent damage. Specimen dimensions guarantee test loads in the elastic region that can be accurately measured by the load cell. Measurements are replicated at least three times for each specimen.

2.2.1. Tensile tests

Tensile tests are carried out on AP and CP specimens according to the ASTM standards D3039 [24] and D3518 [25], respectively. As shown in Figure 1, strains in the longitudinal direction are measured with an extensometer (Instron, Model 2620-604 with gauge length 25 mm).

Figure 1: Tensile test with extensometer on an investigated specimen.

Tensile tests are run with a constant speed of the testing machine cross head of 2 mm/min in order to measure the Young's modulus in the longitudinal direction in the quasi-static loading condition.

In case of damaged specimens, the total specimen length is subdivided in regions with length equal to the extensometer gauge length (i.e., 25 mm). The specimen length for AP and CP damaged specimens is therefore subdivided in six and

ten regions, respectively. As shown in Figure 2, the clamping free area, which is accessible during the test, consists of the four central regions in case of AP specimens and of the six central regions in case of CP specimens. These central regions are called the unclamped regions in the following.

Figure 2: CP and AP specimens with subdivision in clamped and unclamped regions.

In every specimen, impacts are randomly applied in the unclamped regions.

Tensile tests on each damaged specimen are repeated four times at the same load level when testing AP specimens and six times when testing CP specimens. In each repetition, the extensometer is moved from one unclamped region to the next. Therefore, four strain values, corresponding to each of the four unclamped regions, are measured for every AP damaged specimen, whereas six strain values, corresponding to each of the six unclamped regions, are measured for every CP damaged specimen. The ratio between the applied stress (applied load over measured cross-sectional area) and the local strain measured in each unclamped region provides the values of the local residual Young's modulus along the whole unclamped length of the specimen:

$$E_i = \frac{F/(t \cdot w)}{\varepsilon_i}, \quad (1)$$

where E_i denotes the residual Young's modulus of the i -th region, ε_i is the strain measured in the i -th region, F is the applied load and t and w are the specimen thickness (i.e., about 6.7 mm) and width (i.e., about 12.7 mm for AP specimens and about 20 mm for CP specimens), respectively.

2.2.2. IET tests

In IET tests, the specimen is excited with an impulse in order to measure its fundamental resonant frequency. A microphone senses the mechanical vibrations induced by the impulse and passes the measured signal to a data acquisition system (National Instruments NI USB-6210) and finally to an analyser (Buzz-o-sonic[®]) that provides the fundamental resonant frequency (Figure 3).

Figure 3: Experimental system used for IET tests.

Specimen supports, impulse and microphone locations are defined in order to drive a specific vibration mode of the specimen. The 'longitudinal vibration' configuration recommended by the ASTM standard E1876 [20] is adopted in the present study (Figure 4). Polyurethane foam strips are utilized to support the specimen.

Figure 4: IET system in longitudinal mode configuration.

The measured resonant frequency, the specimen dimensions and the specimen mass are used to compute the dynamic Young's modulus, according to the ASTM standard [20]:

$$E_{IET} = \frac{4 \cdot m \cdot L \cdot f^2}{t \cdot w \cdot K}, \quad (2)$$

where m is the specimen mass, L is the specimen length (i.e., about 150 mm for AP specimens and about 250 mm for CP specimens), f denotes the resonant frequency measured by the analyser and $K = 1 - \frac{2 \cdot \pi^2 \cdot \nu^2 \cdot (w^2 + t^2)}{24 \cdot L^2}$ is a correction factor which accounts for the finite diameter-to-length ratio and Poisson's ratio ν [20]. The correction factor depends on the specimen type and attains a minimum value equal to 0.997 with AP specimens, since they exhibit the largest Poisson's ratio (0.65) and the largest diameter-to-length ratio (0.006). If, in Equation (2), K is supposed equal to 1, the maximum error in the computation of the Young's modulus is a negligible value below 0.3%. Therefore, for the sake of simplicity, K is supposed equal to 1 in the following.

Figure 5 shows typical frequency spectra obtained with IET tests on undamaged and damaged AP and CP specimens.

Figure 5: IET frequency spectra for different specimen types: a) Undamaged AP specimen; b) Damaged AP specimen; c) Undamaged CP specimen; d) Damaged CP specimen.

As shown in Figure 5, the resonant frequency is clearly identifiable in each spectrum and no misreading is thus possible in analysing data.

For each tested specimen, the resonant frequency is measured with a 1 Hz resolution, dimensions are measured with a centesimal digital caliper and mass is measured through a digital scale with 0.1 g resolution. For each measured quantity, five replications are performed on each specimen. Tables 1 and 2 report the data for the calculation of the uncertainty [26] on E_{IET} for one undamaged AP specimen and one undamaged CP specimen, respectively. Very similar results are obtained for all the other AP and CP specimens.

Table 1: Uncertainty on Young's moduli for AP specimens.

Table 2: Uncertainty on Young's moduli for CP specimens.

According to Tables 1 and 2, the combined uncertainty on E_{IET} is 0.1 GPa for every AP specimen and 0.8 GPa for every CP specimen.

3. Results and Discussion

The Young's modulus is measured on undamaged and damaged specimens. Values measured on undamaged specimens are used as reference for quantifying the decrement of the elastic properties induced by damage.

3.1. Undamaged specimens

The base Young's modulus of the undamaged composite is evaluated from tensile and IET tests for AP and CP specimens, according to Equations (1) and (2). In particular, when evaluating the base Young's modulus from the tensile test, a single strain value is measured with the extensometer applied in the central zone of the unclamped length. Tables 3 and 4 report the average values and the standard deviations (in case of IET tests the uncertainty is reported) for the four tested AP and CP specimens, respectively.

Table 3: Young's moduli of undamaged AP specimens.

According to the values reported in Tables 3 and 4, the IET proves effective in measuring the Young's modulus of AP and CP undamaged specimens. For both specimen types, IET values are very close to the values measured from the tensile tests. IET provides slightly larger values for both AP and CP specimens, except for the CP1 specimen.

Table 4: Young's moduli of undamaged CP specimens.

Some slight differences between the results from the two evaluation techniques can be ascribed, in the authors' opinion, to the strain rate effect (i.e., the IET value is a dynamic Young's modulus) and to the intrinsic inhomogeneity of composite materials. The IET provides an overall specimen Young's modulus. On the other hand, the Young's modulus obtained from tensile tests depends on the local strain measured through the extensometer and therefore can be considered as a local Young's modulus. In a homogenous material, the local Young's modulus is equivalent to the overall specimen Young's modulus; whereas in an inhomogeneous composite material, the local Young's modulus may vary along the specimen length. Therefore, the overall Young's modulus measured through the IET can be slightly different from the local Young's modulus measured through a tensile test.

3.2. Damaged specimens

The residual Young's modulus of the damaged composite is evaluated from tensile and IET tests for AP and CP specimens, according to Equations (1) and (2).

Tables 5 and 6 report the overall Young's modulus measured with IET tests and the local values of the Young's modulus measured from tensile tests on each unclamped region for AP and CP specimens, respectively.

Table 5: Residual Young's moduli in damaged AP specimens: Local values in each unclamped region from tensile tests and overall values from IET tests.

According to Tables 5 and 6, in the case of damaged specimens, the IET provides an overall value of the Young's modulus that is not representative of any specific unclamped region of the specimen.

Table 6: Residual Young's moduli in damaged CP specimens: Local values in each unclamped region from tensile tests and overall values from IET tests.

For each damaged specimen, this overall residual Young's modulus depends on the extension and severity of damage in the whole specimen. In particular, a very localized damage is not expected to significantly change the overall base Young's modulus of the specimen.

In order to find an analytical expression that correlates the overall value from IET and the local values from tensile tests, the damaged specimen can be modelled through a series of elastic bodies subjected to a longitudinal load (Figure 6).

Figure 6: Mechanical model of a damaged specimen subjected to a longitudinal load.

According to the series model represented in Figure 6, the overall stiffness k_{TOT} is given by:

$$k_{TOT} = \frac{1}{\sum_{i=1}^n \frac{1}{k_i}} = \frac{1}{\sum_{i=1}^n \frac{L_i}{E_i A}} = \frac{A}{\sum_{i=1}^n \frac{L_i}{E_i}}, \quad (3)$$

where, for each specimen region i , A is the cross-sectional area (which is approximately constant along the specimen length), L_i is the length and E_i denotes the residual Young's modulus, according to Equation (1).

On the other hand, the overall stiffness can be computed from the overall Young's modulus, as follows:

$$k_{TOT} = \frac{E_{TOT} A}{L_{TOT}} = \frac{E_{TOT} A}{\sum_{i=1}^n L_i}, \quad (4)$$

where $L_{TOT} = \sum_{i=1}^n L_i$ is the total specimen length and E_{TOT} denotes the overall Young's modulus that can be measured with an IET test.

The relationship between the overall Young's modulus measured from IET and the local residual Young's moduli measured from tensile tests can be easily obtained by taking into account Equations (3) and (4):

$$E_{TOT} = \frac{\sum_{i=1}^n L_i}{\sum_{i=1}^n \frac{L_i}{E_i}} = \frac{nL}{L \sum_{i=1}^n \frac{1}{E_i}} = \frac{n}{\sum_{i=1}^n \frac{1}{E_i}}, \quad (5)$$

where L is the constant length value of each specimen region (i.e., $L = 25$ mm).

Table 7 compares the values obtained from Equation (5) with the experimental IET values reported in Tables 5 and 6.

Since no extensometer measurement is possible in the clamped regions, nor any damage is likely to occur in these regions, the local Young's modulus for the clamped regions is assumed equal to the largest Young's modulus measured in the unclamped regions for the computation of E_{TOT} through Equation (5).

According to Table 7, values from IET and tensile tests are in good agreement, with larger errors for the longer CP specimens. As for the undamaged specimens, IET provides, on average, slightly larger values for both AP and CP specimens.

Table 7: Residual Young's moduli in damaged specimens from tensile and IET tests.

A percent decrement of the local residual Young's modulus in each unclamped region can be conservatively estimated by assuming, as reference, the largest Young's modulus measured along the specimen. An average percent decrement for each damaged specimen can then be estimated by averaging the percent decrement values associated to each region. Table 8 reports the average percent decrement for each damaged specimen. For sake of comparison, the percent decrement measured with the IET is reported alongside.

Table 8: Percent decrement of Young's modulus in damaged specimens from tensile and IET tests.

According to Table 8, the overall percent decrements measured from IET values are in good agreement with the average percent decrements calculated from the local values of tensile tests, with larger errors for the longer CP specimens. IET

provides, on average, larger percent decrement for both specimen types. Therefore, IET can be considered a more sensitive methodology for assessing the overall decrement of elastic properties in damaged composite laminates.

4. Conclusions

The Young's modulus of a thick composite laminate for automotive applications was investigated before and after the application of a local random damage. The investigation was performed by carrying out standard tensile tests on a hydraulic testing machine and non-destructive tests based on the Impulse Excitation Technique (IET).

The following conclusions can be drawn from the experimental results:

- IET is a rapid and effective method for measuring the longitudinal Young's modulus in undamaged composite specimens.
- Compared to the standard mechanical characterization, which is based on local strain measurements, IET provides more repetitive results, since measurements are less affected by the typical local inhomogeneity of thick composite laminates.
- IET provides, on average, slightly larger values for the Young's modulus for both AP and CP specimens, probably as a result of the strain rate effect.
- Being a global measurement technique, IET is unable to provide an estimate of the local residual Young's modulus that could be measured with an extensometer across the locally damaged area.
- However, compared to the standard mechanical characterization, IET proved more sensitive to monitor overall Young's modulus reductions in damaged composites.

References

1. Ibrahim ME. Nondestructive evaluation of thick-section composites and sandwich structures: A review. *Composites: Part A* 2014;64:36-48.
2. Hagemaijer DJ, Fassbender RH. Nondestructive testing of advanced composites. *Material Evaluation* 1979;37:43-49.
3. Stone DEW. Non-destructive inspection of composite materials for aircraft structural applications. *British Journal of Nondestructive Testing* 1978;20:65-75.
4. Bar-Cohen Y. NDE of fiber-reinforced composite materials – a review. *Material Evaluation* 1986;44:446-454.
5. Scott IG, Scala CM. A review of non-destructive testing of composite materials. *NDT & E International* 1982;15:75-86.
6. Reynolds WN. Nondestructive testing (NDT) of fibre-reinforced composite materials. *Material and Design* 1985;5:256-270.

7. Prakash R. Non-destructive testing of composites. *Composites* 1980;11:217-224.
8. Smith RA. Advanced NDT of composites in the United Kingdom. *Material Evaluation* 2007;65:697-710.
9. Pei X, Chen L, Li J, Tang Y, Chen K. Effect of damage on the vibration modal of a novel three-dimensional and four-directional braided composite T-beam. *Composites Part B: Engineering* 2016;86:108-119.
10. Hassen AA, Taheri H, Vaidya UK. Non-destructive investigation of thermoplastic reinforced composites. *Composites Part B: Engineering* 2016;97:244-254.
11. Taraghi I, Fereidoon A. Non-destructive evaluation of damage modes in nanocomposite foam-core sandwich panel subjected to low-velocity impact. *Composites Part B: Engineering* 2016;103:51-59.
12. Wolfenden A, Harmouche MR, Blessing GV, Chen YT, Terranova P, Dayal V, Kinra VK, Lemmens JW, Philips RR, Smith JS, Mahmoodi P, Wann RJ. Dynamic young's modulus measurements in metallic materials: results of an interlaboratory testing program. *Journal of Testing and Evaluation* 1989;17:2-13.
13. Zhu K, Li C, Zhu Z, Liu CS. Measurement of the dynamic Young's modulus of porous titanium and Ti_6Al_4V . *Journal of Material Science* 2007;42:7348-7353.
14. Digilov RM. Flexural vibration test of a cantilever beam with a force sensor: fast determination of Young's modulus. *European Journal of Physics* 2008;29:589-597.
15. Hauert A, Rossoll A, Mortensen A. Young's modulus of ceramic particle reinforced aluminium: Measurement by the Impulse Excitation Technique and confrontation with analytical models. *Composites: Part A* 2009;40:524-529.
16. Singh M, Salem JA. Mechanical properties and microstructure of biomorphic silicon carbide ceramics fabricated from wood precursor. *Journal of the European Ceramic Society* 2002;22:2709-2717.
17. He L, Lin Z, Wang J, Bao Y, Li M, Zhou Y. Synthesis and Characterization of Bulk $Zr_2Al_3C_4$. *Journal of the American Ceramic Society* 2007;90:3687-3689.
18. Pabst W, Gregorová E, Malangré D, Hostaša J. Elastic properties and damping behaviour of alumina-zirconia composite at room temperature. *Ceramic International* 2012;38:5931-5939.
19. ASTM Committee C28. ASTM C1259-15 Standard test method for dynamic Young's modulus, shear modulus, and Poisson's ratio for advanced ceramics by impulse excitation of vibration. West Conshohocken: ASTM International, 2015.
20. ASTM Committee E28. ASTM E1876-15 Standard test method for dynamic Young's modulus, shear modulus, and Poisson's ratio by impulse excitation of vibration. West Conshohocken: ASTM International, 2015.
21. Viens MJ, Johnson JJ. Determination of elastic moduli of fiber-resin composites using an impulse excitation technique. NASA Technical Memorandum 104629, 1996.

22. Gibson RF. Modal vibration response measurements for characterization of composite materials and structures. *Composite Science and Technology* 2000;60:2769-2780.
23. Zhou J, Chui YH, Gong M, Hu L. Elastic properties of full-size mass timber panels: Characterization using modal testing and comparison with model predictions. *Composites Part B: Engineering* 2017;112:203-212.
24. ASTM Committee D30. ASTM D3039-14 Standard test method for tensile properties of polymer matrix composite materials. West Conshohocken: ASTM International, 2014.
25. ASTM Committee D30. ASTM D3518-13 Standard test method for in-plane shear response of polymer matrix composite materials by tensile test of a $\pm 45^\circ$ laminate. West Conshohocken: ASTM International, 2013.
26. JCGM/WG1. JCGM 100:2008 Evaluation of measurement data – Guide to the expression of uncertainty in measurement. JCGM 2008, 2010.

Figure captions

Figure 1: Tensile test with extensometer on an investigated specimen.

Figure 2: CP and AP specimens with subdivision in clamped and unclamped regions.

Figure 3: Experimental system used for IET tests.

Figure 4: IET system in longitudinal mode configuration.

Figure 5: IET frequency spectra for different specimen types: a) Undamaged AP specimen; b) Damaged AP specimen; c) Undamaged CP specimen; d) Damaged CP specimen.

Figure 6: Mechanical model of a damaged specimen subjected to a longitudinal load.

Table 1

Table 1: Uncertainty on measured Young's moduli for AP specimens.

<i>Quantity</i>	<i>Symbol</i> x_i	<i>Units</i>	<i>Value</i>	<i>Source</i>	<i>Standard uncertainty component</i> $u(x_i)$	<i>Sensitivity coefficient</i> $c_i = \partial E_{IET} / \partial x_i$	<i>Standard uncertainty</i> $u_i(E_{IET}) = c_i u(x_i)$
<i>Mass</i>	m	kg	19.3E-3	Replications Resolution	81E-6 29E-6	6.92E+11	5.62E+7 2.00E+7
<i>Length</i>	L	m	150.7E-3	Replications Resolution	528E-6 29E-6	8.86E+10	4.68E+7 2.56E+6
<i>Frequency</i>	f	Hz	9958	Replications Resolution	2.8 0.3	2.68E+6	7.51E+6 7.74E+5
<i>Thickness</i>	t	m	6.7E-3	Replications Resolution	25E-6 29E-6	-1.99E+12	4.94E+7 5.75E+8
<i>Width</i>	w	m	12.9E-3	Replications Resolution	29E-6 29E-6	-1.03E+12	2.95E+7 2.99E+7
<i>Young's modulus</i>	E_{IET}	Pa	$E_{IET} = \frac{4 \cdot m \cdot L \cdot f^2}{t \cdot w} = 13.3E+9$	-	-	-	$u_i(E_{IET}) = \sqrt{\sum u_i^2(E_{IET})} = 0.1E+9$

Table 2

Table 2: Uncertainty on measured Young's moduli for CP specimens.

<i>Quantity</i>	<i>Symbol</i> x_i	<i>Units</i>	<i>Value</i>	<i>Source</i>	<i>Standard uncertainty component</i> $u(x_i)$	<i>Sensitivity coefficient</i> $c_i = \partial E_{IET} / \partial x_i$	<i>Standard uncertainty</i> $u_i(E_{IET}) = c_i u(x_i)$
<i>Mass</i>	<i>m</i>	kg	48.4E-3	Replications Resolution	528E-6 29E-6	1.11E+12	5.83E+8 3.19E+7
<i>Length</i>	<i>L</i>	m	250.2E-3	Replications Resolution	487E-6 144E-6	2.14E+11	1.04E+8 3.09E+7
<i>Frequency</i>	<i>f</i>	Hz	12149	Replications Resolution	0.7 0.3	8.81E+6	5.97E+6 2.54E+6
<i>Thickness</i>	<i>t</i>	m	6.7E-3	Replications Resolution	50E-6 29E-6	-7.98E+12	4.01E+8 2.30E+8
<i>Width</i>	<i>w</i>	m	20.0E-3	Replications Resolution	89E-6 29E-6	-2.68E+12	2.37E+8 7.74E+7
<i>Young's modulus</i>	E_{IET}	Pa	$E_{IET} = \frac{4 \cdot m \cdot L \cdot f^2}{t \cdot w} = 53.5E+9$	-	-	-	$u_i(E_{IET}) = \sqrt{\sum u_i^2(E_{IET})} = 0.8E+9$

Table 3

Table 3: Young's moduli of undamaged AP specimens.

<i>Specimen denomination</i>	<i>Young's moduli [GPa]</i>	
	<i>Tensile tests</i>	<i>IET tests</i>
	<i>AP1</i>	13.1 (-)
<i>AP2</i>	13.0 (0.1)	13.4 (0.1)
<i>AP3</i>	13.3 (0.2)	13.7 (0.1)
<i>AP4</i>	13.3 (0.1)	13.9 (0.1)

Note: Standard deviations, reported in parentheses, are omitted if less the 0.1 GPa.

Table 4

Table 4: Young's moduli of undamaged CP specimens.

<i>Specimen denomination</i>	<i>Young's moduli [GPa]</i>	
	<i>Tensile tests</i>	<i>IET test</i>
	<i>CP1</i>	56.6 (0.2)
<i>CP2</i>	52.7 (0.5)	53.0 (0.8)
<i>CP3</i>	50.1 (0.1)	52.5 (0.8)
<i>CP4</i>	50.3 (0.1)	52.9 (0.8)

Note: Standard deviations are reported in parentheses.

Table 5

Table 5: Residual Young's moduli in damaged AP specimens: Local values in each unclamped region from tensile tests and overall values from IET tests.

<i>Specimen denomination</i>	<i>Residual Young's moduli [GPa]</i>				
	<i>Tensile tests (Local value in each unclamped region)</i>				<i>IET tests (Overall values)</i>
	Region 1	Region 2	Region 3	Region 4	
<i>AP1</i>	12.8	7.4	11.1	13.8	11.8
<i>AP2</i>	13.5	7.7	10.8	13.2	11.8
<i>AP3</i>	12.9	9.7	11.5	13.7	12.1
<i>AP4</i>	11.0	9.3	14.1	14.0	12.3

Table 6

Table 6: Residual Young's moduli in damaged CP specimens: Local values in each unclamped region from tensile tests and overall values from IET tests.

<i>Specimen denomination</i>	<i>Residual Young's moduli [GPa]</i>						<i>IET tests (Overall values)</i>
	<i>Tensile tests (Local value in each unclamped region)</i>						
	Region 1	Region 2	Region 3	Region 4	Region 5	Region 6	
<i>CP1</i>	49.9	14.3	57.3	54.7	58.5	53.5	46.7
<i>CP2</i>	61.9	14.7	51.6	59.1	55.9	57.8	46.3
<i>CP3</i>	21.3	15.8	43.9	54.6	52.4	53.1	41.9
<i>CP4</i>	51.3	18.2	52.0	50.9	57.3	55.9	44.8

Table 7

Table 7: Residual Young's moduli in damaged specimens from tensile and IET tests.

<i>Specimen denomination</i>	<i>Residual Young's moduli [GPa]</i>			<i>Average Percent Error</i>
	<i>Tensile tests</i>	<i>IET tests</i>	<i>Percent Error</i>	
	<i>(E_{TOT})</i>	<i>(E_{IET})</i>		
<i>AP1</i>	11.5	11.8	+2.5%	+0.6%
<i>AP2</i>	11.5	11.8	+2.6%	
<i>AP3</i>	12.3	12.1	-1.9%	
<i>AP4</i>	12.4	12.3	-0.8%	
<i>CP1</i>	43.5	46.7	+7.4%	+4.3%
<i>CP2</i>	45.4	46.3	+2.0%	
<i>CP3</i>	38.1	41.9	+10.0%	
<i>CP4</i>	45.8	44.8	-2.2%	

Table 8

Table 8: Percent decrement of Young's modulus in damaged specimens from tensile and IET tests.

<i>Specimen denomination</i>	<i>Percent decrement</i>		<i>Difference</i>	<i>Average difference</i>
	<i>Tensile tests</i>	<i>IET tests</i>		
	<i>(Average values)</i>	<i>(Overall values)</i>		
<i>AP1</i>	-12.2%	-11.3%	+1.0%	-1.4%
<i>AP2</i>	-10.8%	-11.9%	-1.2%	
<i>AP3</i>	-8.5%	-11.7%	-3.2%	
<i>AP4</i>	-9.4%	-11.5%	-2.1%	
<i>CP1</i>	-10.7%	-12.7%	-2.0%	-3.2%
<i>CP2</i>	-11.3%	-12.6%	-1.3%	
<i>CP3</i>	-15.8%	-20.2%	-4.4%	
<i>CP4</i>	-10.2%	-15.3%	-5.1%	

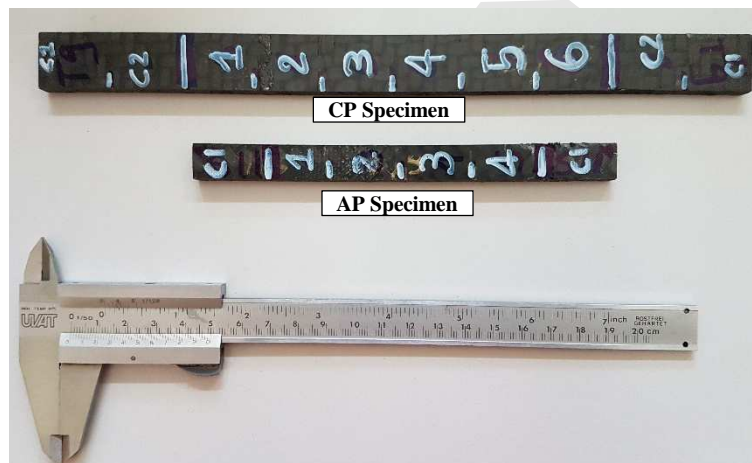
Figure 1**Figure 1:** Tensile test with extensometer on an investigated specimen.**Figure 2****Figure 2:** CP and AP specimens with subdivision in clamped and unclamped regions.

Figure 3

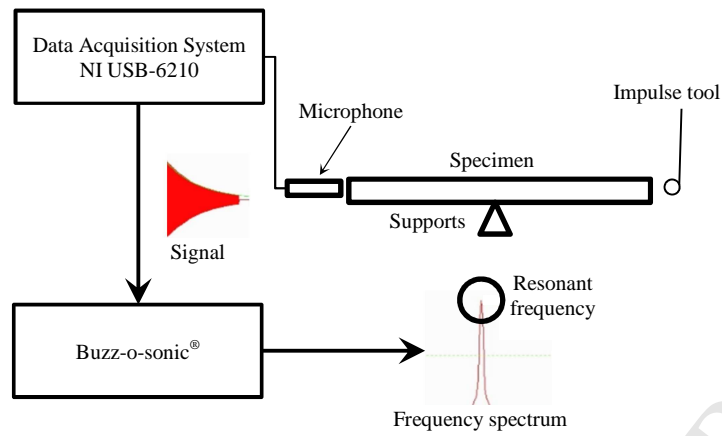


Figure 3: Experimental system used for IET tests.

Figure 4

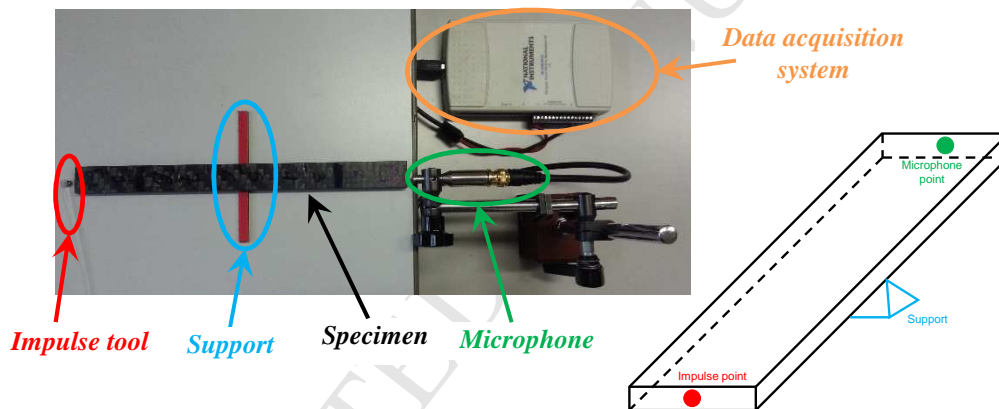


Figure 4: IET system in longitudinal mode configuration.

Figure 5

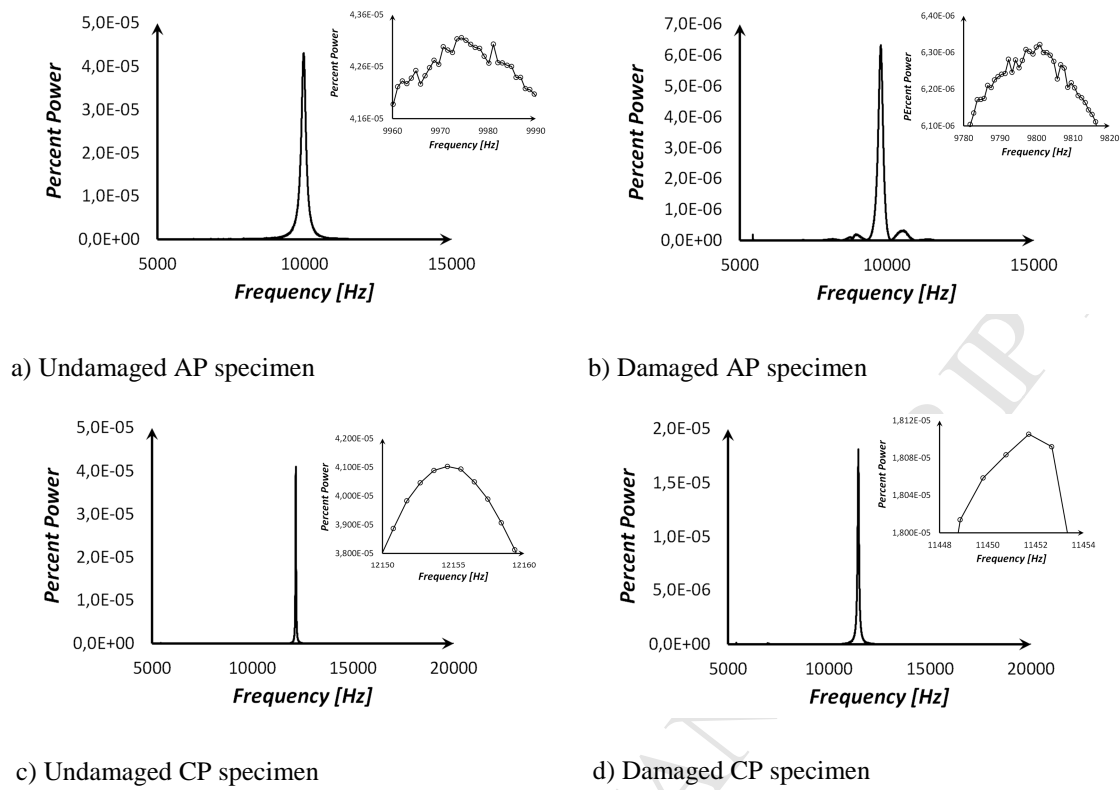


Figure 5: IET frequency spectra for different specimen types: a) Undamaged AP specimen; b) Damaged AP specimen; c) Undamaged CP specimen; d) Damaged CP specimen.

Figure 6

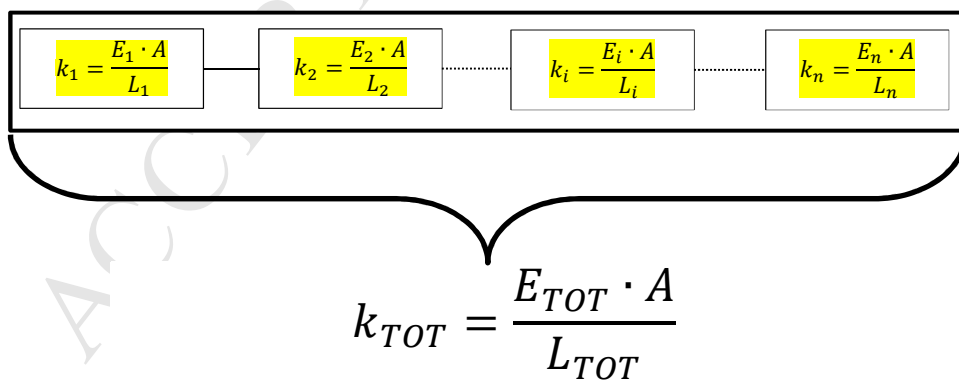


Figure 6: Mechanical model of a damaged specimen subjected to a longitudinal load.