

Direct current microgrids based on solar power systems and storage optimization, as a tool for cost-effective rural electrification

*Original*

Direct current microgrids based on solar power systems and storage optimization, as a tool for cost-effective rural electrification / Gandini, D., de Almeida, A.T.. - In: RENEWABLE ENERGY. - ISSN 0960-1481. - 111:(2017), pp. 275-283. [10.1016/j.renene.2017.04.009]

*Availability:*

This version is available at: 11583/2673068 since: 2018-05-24T15:18:45Z

*Publisher:*

Elsevier Ltd

*Published*

DOI:10.1016/j.renene.2017.04.009

*Terms of use:*

This article is made available under terms and conditions as specified in the corresponding bibliographic description in the repository

*Publisher copyright*

Elsevier postprint/Author's Accepted Manuscript

© 2017. This manuscript version is made available under the CC-BY-NC-ND 4.0 license  
<http://creativecommons.org/licenses/by-nc-nd/4.0/>. The final authenticated version is available online at:  
<http://dx.doi.org/10.1016/j.renene.2017.04.009>

(Article begins on next page)

# Direct current microgrids based on solar power systems and storage optimization, as a tool for cost-effective rural electrification

Dario Gandini

*Politecnico di Torino,*

*Dep. Electronics and Telecommunication, Italy*

Anibal T. de Almeida

*ISR, University of Coimbra,*

*Dep. Electrical Engineering, Portugal*

---

## **Abstract**

Around 20 % of world population lives without electricity access, most of them are concentrated in Sub-Saharan rural areas. Traditional approaches to electrify rural areas imply capital intensive infrastructures and large investments, while DC microgrids, based on renewable sources and storage systems, can be easily implementable and lead to cost effective solutions. The use of super efficient appliances can dramatically reduce the households electricity consumption, leading to smaller and cheaper systems. In this study an analysis of the use of efficient DC appliances is performed starting by essential energy services. Solar home system design optimization can be achieved by the evaluation of irradiation variation and the load requirements, finding the most cost-effective solution. Rural electrification can have a major impact to drastically improve the quality of life of millions of people through the sustainable use of solar energy.

*Keywords:*

DC microgrid, solar home system, SHS, energy storage, rural electrification

---

1 **1. Introduction - Electricity poverty**

2 Worldwide 1.3 billion people, equivalent to 18 % of the global population,  
3 live without access to electricity [IEA World (2014)]. Sub-Saharan Africa  
4 has more people living without access to electricity than any other World  
5 region, more than 620 million people, about half of the global total. It is  
6 also the only region in the World where the number of people living without  
7 electricity is increasing. Since 2000, the number of people without electricity  
8 rose by around 100 million. Nearly 80 % of those lacking access to electricity  
9 are in poor rural areas. [IEA Africa (2014)]

10

11 A lack of access to such energy services often re-sults in relying on ex-  
12 pensive, inefficient and hazardous alternatives. For example, households can  
13 typically spend 20-25 % of their income on kerosene, although the potential  
14 cost of useful lighting can be very small. Each year 4.3 million premature  
15 deaths, of which nearly 600 thousands are in Africa, can be attributed to  
16 household air pollution resulting from the traditional use of solid fuels, such  
17 as fuel wood and charcoal. [WHO (2014)]

18

19 Often, the traditional approach to serve these communities is to extend  
20 the conventional electric power grid. This approach may often be technically  
21 and financially inefficient due to a combination of capital scarcity, reduced  
22 grid reliability, extended building times and construction challenges to con-

23 nect remote areas. In principle, sustainably financed and operated microgrids  
24 based on renewable energies can overcome many of the challenges faced by  
25 traditional rural electrification strategies. [Schnitzer et al. (2014)]

26

27 The International Energy Agency (IEA) estimates that more than 50 % of  
28 those without electricity access could be served by off-grid alternatives [IEA  
29 Africa (2014)]. New decentralized models based on renewable generation  
30 and innovative payment schemes are gaining ground as a viable alternative.  
31 These initiatives are frequently rely on government and international donor  
32 funds for start-up, scale-up activities, research or development.

33

## 34 **2. Traditional approach: costs and losses**

35 About 8.5 % of the global power production was lost in transmission and  
36 distribution networks in 2011, of which roughly 87 % was estimated to be  
37 due to technical losses. [Waide & Scholand (2014)] After the losses in power  
38 lines and cables, transformers are the second largest source of losses in elec-  
39 tricity networks. Line losses in conductors and cables will typically account  
40 for about half of system technical losses whereas those in transformers will  
41 typically account for 45-50 %. Although they can be quite efficient, distri-  
42 bution transformers are costly and are estimated to account for 36 % of all  
43 global technical losses. [De Almeida et al. (2016)] Figure 1 shows the trans-  
44 former efficiency and the different losses, as a function of the load, for a small  
45 75 kVA oil-immersed distribution transformer.

46

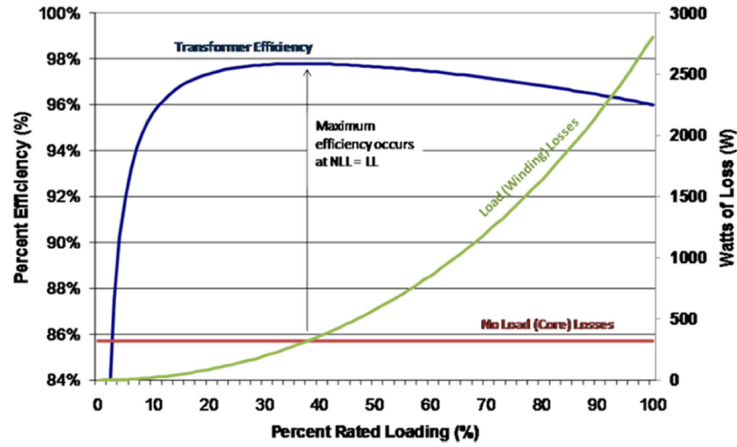

Figure 1: Efficiency and losses combination for a 75 KVA oil-immersed transformer [Eide et al. (2010)]

47        The transformer losses have two main components: core losses and cop-  
 48 per losses. Maximum efficiency is reached when the two losses are equal, or  
 49 rather at particular value of load. Due to variable consumption, particularly  
 50 for residential case, a power transformer may undergo a considerable load  
 51 variation during a 24 hours period. There may be intervals during which  
 52 transformer carries a substantially rated load and others during which trans-  
 53 former carries only a small part of its rating. At very low loads (below  
 54 10 %), a situation likely to happen in most of the time in rural electrifica-  
 55 tion, the efficiency dramatically drops, as the core losses are almost constant.

56

57        To electrify a rural area with a few users, a system composed by so-  
 58 lar photovoltaic (PV) and storage, can have a system efficiency similar to  
 59 a conventional grid-connected system and an impressive investment cost re-  
 60 duction. In Table 1 the typical distribution system hardware costs are sum-

Equipment	Cost example
Lines	30.000 \$/km: 46 kV
Feeders	88.000 880.000 \$/km
Rural Substation	23 \$/kW (e.g. 1 MW = 23.000 \$)
Mainline, conduit	300 \$/m
Lateral, conduit	200 \$/m
Installation of transformer	2.700 \$
Installation of - 3 switches	20.800 \$
Connections	60 \$/kW
1-phase transformer	50 kVA: 3.000 \$
2-phase transformer	75 kVA: 7.800 \$

Table 1: Example of distribution system hardware cost in US\$, [Knap et al. (2000)]

61 marized [Knap et al. (2000)] and in the next section the solar PV and lithium  
62 batteries cost trends are presented.

### 63 **3. Solar PV and lithium storage cost trends**

64 Combined use of renewable energy sources (RES) and storage is becom-  
65 ing a more and more an interesting solution to increase electricity access in  
66 rural areas. In the last ten years, both the prices of solar photovoltaic (PV)  
67 and of storage are coming down fast. In a high solar radiation region, as is  
68 most of Africa, solar PV electricity is the most interesting and cost-effective  
69 option. Figure 2 presents the collection of some PV module costs focused on  
70 different markets [Mehta (2013), Fraunhofer (2016), Bloomberg NEF (2015),  
71 NREL (2016)]. PV module cost was near 2 USD per watt in 2010, nowa-

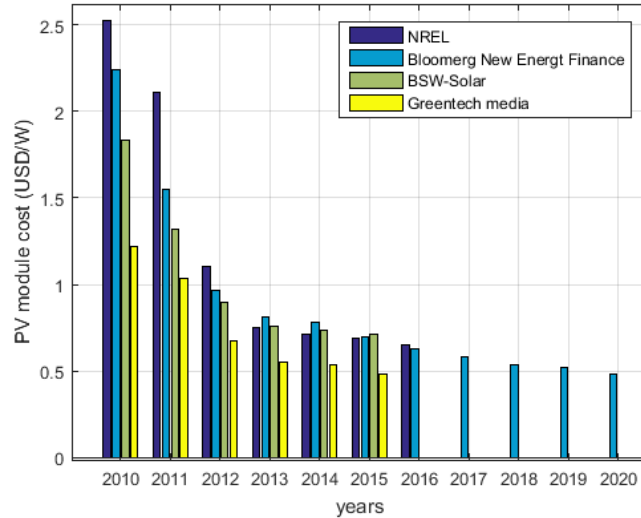

Figure 2: Solar PV module cost outlook 2010-2020. Greentech Media reports modules cost realized by Chinese companies [Mehta (2013)], BSW Solar are cost of German market [Fraunhofer (2016)], Bloomberg New Energy finance includes a modules cost forecast up to 2020 [Bloomberg NEF (2015)], NREL presents the costs of US market [NREL (2016)]

72 days is around 0.5 USD and cost estimation, in 2020, is down to 0.4 USD  
 73 per watt. Modules costs are only a slice of total costs: power electronics  
 74 equipment coupled to module can double total cost [Fraunhofer (2016)]; the  
 75 sum of hardware equipments and soft costs, in 2009, were 64 % of total cost  
 76 and nowadays they are 78 % [NREL (2016)].

77

78 With recent technology and mass-market developments (namely due to  
 79 electric vehicles) lithium-based batteries are the most cost-effective storage  
 80 option and, in the same way as PV modules, lithium-based batteries cost  
 81 is also coming down, [Boucar& Ramchandra (2015)]. Figure 3 shows cost  
 82 trends of Li-ion batteries. In recent surveys [Nykqvist & Nilsson (2015)] a

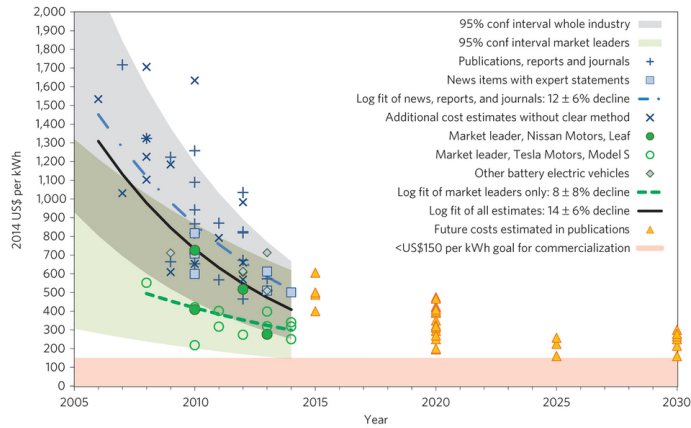

Figure 3: Cost of Li-ion battery packs in BEV. Source: [Nykvist & Nilsson (2015)]

83 value under 150 US\$/kWh is considered the goal for commercialization by  
 84 2020. Lithium batteries, as well as PV modules, need electronics equipment,  
 85 as power electronics converters and a battery management system; the to-  
 86 tal cost for consumers includes also commercialization and installation costs  
 87 that, with the electronics equipment, can be responsible for 50-80 % of the  
 88 total cost [Morris (2014), IRENA (2015)]. These values will be used in the  
 89 following analysis to compute the economic sustainability of direct current  
 90 (DC) microgrids based on the combination of PV modules and lithium bat-  
 91 teries for storage.

#### 92 4. Direct current: benefits on supply system and appliances

93 Direct current (DC) networks have the potential to increase the afford-  
 94 ability of rural electrification in developing countries by reducing complex-  
 95 ity, costs and by increasing total system efficiency. With DC networks, the  
 96 parallelization of generators is easier, avoiding complex synchronization al-

97 algorithms, inverter final stage is not necessary, avoiding the associated invest-  
 98 ment and its losses. Furthermore output filters, that in alternate current  
 99 (AC) network are designed for 50 or 60 Hz, become smaller (necessary to re-  
 100 move only the high switching frequency) with additional increase of system  
 101 efficiency and decrease of power system costs (Figure 4).

102

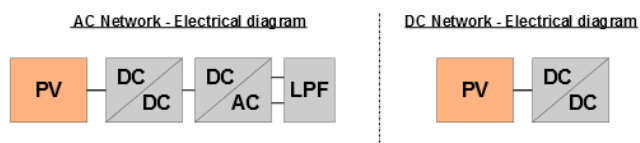

Figure 4: Block diagram of grid connected photovoltaic generator in case of AC or DC network. Where LPF is the inverter output filter, useless in case of DC network

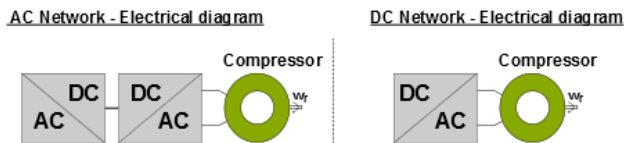

Figure 5: Block diagram of efficient loads (e.g. refrigerators, or air conditioners) in case of AC or DC networks

103 Considering the load side, most of the efficient appliances (e.g. LED  
 104 lighting, TVs, Laptops) are already DC loads. Additionally, the most efficient  
 105 existing AC loads, as refrigerators, fans or air conditioner systems, are driven  
 106 by inverters with a AC/DC converter first stage. In AC networks, there is  
 107 a need for this first stage, whereas in DC networks, this conversion is not  
 108 required, as shown in Figure 5.

109 *4.1. Super efficient appliances*

110 Highly efficiency DC appliances have the potential to increase dramati-  
 111 cally the affordability of DC networks used for rural electrification in develop-  
 112 ing countries by reducing the size of the required power systems. Considering  
 113 an equal level of services, the use of highly efficient DC appliances can have,  
 114 a remarkable impact on system cost reduction [Phadke et al. (2015)]. The  
 115 estimated solar home system (SHS) costs using super-efficient or standard  
 116 appliances are reported in Table (2).

Energy Service	SHS09s	SHS14s	SHS14se
	[USD]	[USD]	[USD]
Light	5	5	15
Battery	275	245	55
PV	500	185	40
Balance of System	100	100	65
Appliances	110	110	180
Total cost	990	645	350

Table 2: Estimated costs of a solar home system (SHS) with efficient or standard appliances in USD (SHS09s: 2009 SHS with standard appliances, SHS14s: 2014 SHS with standard appliances, SHS14se: 2014 SHS with super-efficient appliances) [Phadke et al. (2015)]

117 The U.S. ENERGY STAR <sup>1</sup> program collects the most efficient appli-  
 118 ances of the U.S. market. The first television of the list is a LED 16 inches

---

<sup>1</sup>ENERGY STAR is a U.S. Environmental Protection Agency (EPA) voluntary program that helps businesses and individuals save money and protect our climate through superior energy efficiency. <http://www.energystar.gov/about>

119 screen, with a declared annual consumption of 19 kWh (value related to an  
 120 use of 5 hours per day). A super-efficient DC solution has four times lower  
 121 consumption. Below some of the Global competition LEAP Awards 2014  
 122 winners are shown: the products featured in the Global LEAP Awards are  
 123 among the best off-grid LED room lighting appliances, Table 3, and TVs,  
 124 Table tab:tvleap, in the World. TVs of the list have consume from 5 W to  
 125 10 W and LED lights of the list have consumption in the range 3 ÷ 5 W.

126

Model	LED-DC12V	SLL-L1903D	T5 Tube
Power	5 W	3 W	5 W
Category	LED Bulb	LED Indoor Fixture	LED Indoor Fixture
Rated Luminance	425 lm	310 lm	400 lm
Color Rendering Index (CRI)	82	70	82
Operating Voltage	12 V	8-18 V	12 V

Table 3: Winners of Global LEAP Awards outstanding off-grid LED room lighting appliance competitions 2014. Global LEAP Award is a Clean Energy Ministerial initiative.

127 Thermal comfort is one of the most important services that electricity  
 128 access can improve. In rural areas, particularly in hot-humid climates, the  
 129 thermal comfort can be improved by the use of ceiling fans, as presented in  
 130 [Hwang et al. (2009)] . Nevertheless, ceiling fans contribute significantly to  
 131 residential electricity consumption. For example, in India, ceiling fans alone  
 132 accounted for approximately 6 % of residential energy use in 2000: this figure  
 133 is expected to grow to 9 % in 2020 [Rue du Can et al. (2009)].

Model	SO16M	SO19M	UA23HG 4060AR
Power	6 W	8 W	10 W
Category	Small TV	Medium TV	Large TV
Screen Size	671 $cm^2$	995 $cm^2$	1458 $cm^2$
Functional Voltage Range (Rated)	12-18 V	12-20 V	10.5-14.6 V

Table 4: Winners of Global LEAP Awards outstanding off-grid televisions competitions 2014. Global LEAP Award is a Clean Energy Ministerial initiative.

134

135 In [Shah et al. (2013)] an analysis of the potential for improvement of  
 136 ceiling fan components to reduce global energy consumption and greenhouse  
 137 gas (GHG) emissions, is presented. Improved blade design, the increased use  
 138 of brushless DC (BLDC) motors are identified as cost effective options to  
 139 improve the efficiency of ceiling fans, with a potential power consumption  
 140 saving of more than 50 %.

141

142 In [Desroches & Garbesi (2011)] the most efficient appliances are listed,  
 143 divided by category, specifying the best at the research stage and of the mar-  
 144 ket. Considering the best ceiling fan available on the market, it consumes  
 145 2 W to achieve 19.3  $m^3/min/W$ . The fan, with a diameter of 1.3 m, has  
 146 different operating speeds: minimum 49 rpm consuming 1.49 W, up to a  
 147 maximum of 178 rpm consuming 14.81 W.

148

149 Another essential household service is the possibility to conserve food.

150 Among all refrigerators, available on market, it is possible to find super-  
 151 efficient DC solutions. These appliances use variable speed drive (VSD) to  
 152 drive a high efficiency BLDC motor, leading to an annual consumption less  
 153 than 100 kWh. Obviously, the refrigerator consumption is related to the  
 154 external ambient temperature and its usage (number of times that the door  
 155 is open and duration of opening, amount of food). Below different typical  
 156 energy consumption at different ambient temperatures are shown.

157

Ambient Temperature	Daily Consumption
21 °C	168 Wh
32 °C	276 Wh
43 °C	432 Wh

Table 5: Example of a high efficient DC refrigerator daily consumption related to ambient temperature. Refrigerator capacity: 28l.

158 By using these data, annual consumption at 21 °C is 61 kWh, while it  
 159 is 158 kWh with an ambient temperature of 43 °C; the mean value between  
 160 these two scenarios is 110 kWh/year. Analysing these values, it can be seen  
 161 that the refrigerator works between 13 % of the time, at the lower ambient  
 162 temperature, and 33 % of the total working time, at the higher ambient  
 163 temperature.

164 In rural environment pumps for agricultural irrigation can also be a major  
 165 end-use; their cost is highly variable on pump characteristics (e.g. flow, head)  
 166 that are highly variable on geographic location and crop type as it can be seen  
 167 in [Kelley et al. (2010)].

168 4.2. High efficiency semiconductor technologies

169 High efficiency appliances use power switching converters whose technol-  
 170 ogy can significantly reduce the power losses. In [20] three different inverters  
 171 are compared: two three-level three-phase Silicon inverter topologies are com-  
 172 pared with a standard two-level three-phase topology employing new Silicon  
 173 Carbide (SiC) power transistors. The use of SiC power MOSFET can de-  
 174 crease inverter losses by 60 %, Figure 6.

175

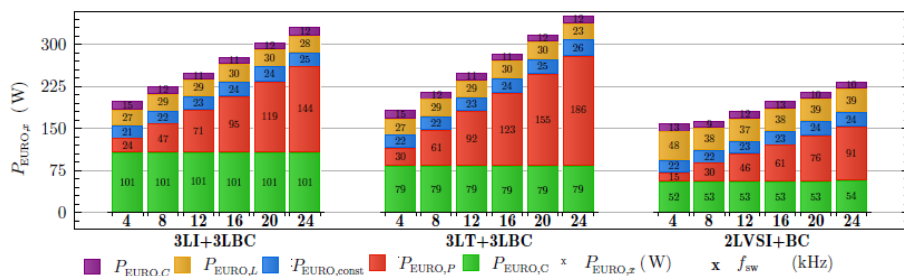

Figure 6: Breakdown of the inverter losses for different switching frequencies. Colour code: violet capacitor losses, yellow inductor losses, blue. cooling system losses, red transistor conduction losses, green switching losses. Sources: [Burkart (2013)]

176 In [Liu et al. (2013)] the performance of an interleaved DC-DC converter  
 177 with new generation SiC transistors is evaluated and the reached efficiency at  
 178 different operating powers is shown in Figure 7. The use of new semiconduc-  
 179 tor technologies, converter structures and control systems are therefore an  
 180 essential element to achieve energy consumption reduction in systems using  
 181 renewable energy sources, namely solar PV.

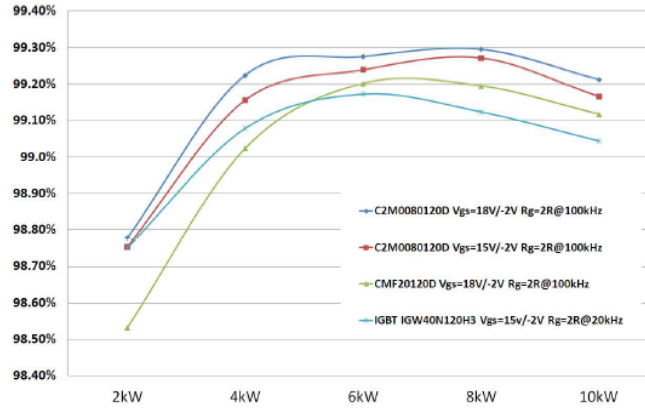

Figure 7: Interleaved converter of 10 kW, efficiency comparison at different frequencies with Gen1 & Gen 2 SiC MOSFET and Si IGBT. Source: [Liu et al. (2013)]

182 *4.3. Eco-Design regulation*

183 In the majority of motor drive system applications, the largest energy  
 184 saving originates from the adjustment of the motor speed and torque to  
 185 the optimal values required for the process. The use of a variable speed  
 186 drive (VSD) for saving energy according to system demands is con-sidered  
 187 an established concept. In a way similar to the regulations for industrial  
 188 motors based on the Eco-Design Directive [Directive 2009/125/EC (2009)]  
 189 efficiency classes for general purpose drives (GPD) are introduced in the  
 190 standards EN 50598-2 [Tsoumas et al. (2014)]. Using the Complete Drive  
 191 Module (CDM) with IE2 classification, the highest, can be targeted coupled  
 192 with super-efficient motors and pumps.

## 193 **5. Electricity consumption in poor rural areas**

194 In [IEA Africa (2014)] is reported that, for those that have electricity  
195 access in sub-Saharan Africa, the average residential electricity consumption  
196 per capita per year is 317 kWh, or 225 kWh excluding South Africa. Con-  
197 sumption per capita is significantly lower in rural areas, typically in the range  
198 of 50 to 100 kWh per year.

199

200 There is no single internationally accepted and adopted definition of  
201 household minimum electricity level of electricity. In [IEA Africa (2014)]  
202 an initial threshold level of electricity consumption for rural households of  
203 250 kWh is considered, whereas a different value is the threshold of [Sanchez  
204 (2010)] that assumes 120 kWh per person (600 kWh per household, assum-  
205 ing five people per household). The Energy Sector Management Assistance  
206 Program (ESMAP) has led the development of a framework that categorizes  
207 household electricity access into six tiers based on supply levels (tier 0 being  
208 no electricity, tiers 4 and 5 being greater than 3 kW of maximum power  
209 demand) and different attributes of supply. [ESMAP (2015)]

210 In the following analysis, first of all, a set of energy services supplied by  
211 high efficient appliances is given and, then the household electricity consump-  
212 tion is obtained. According to [Global LEAP (2015)] the most important  
213 appliances in rural areas are lights, mobile chargers, televisions, refrigera-  
214 tors and fans. In Table 6 the used essential energy services, daily use and  
215 consumption are summarized; assuming load profiles similar to European  
216 consumption behavior, the consumption profiles shapes are extracted from  
217 [De Almeida et al. (2011)]. Figure 8 shows the load diagram of a village

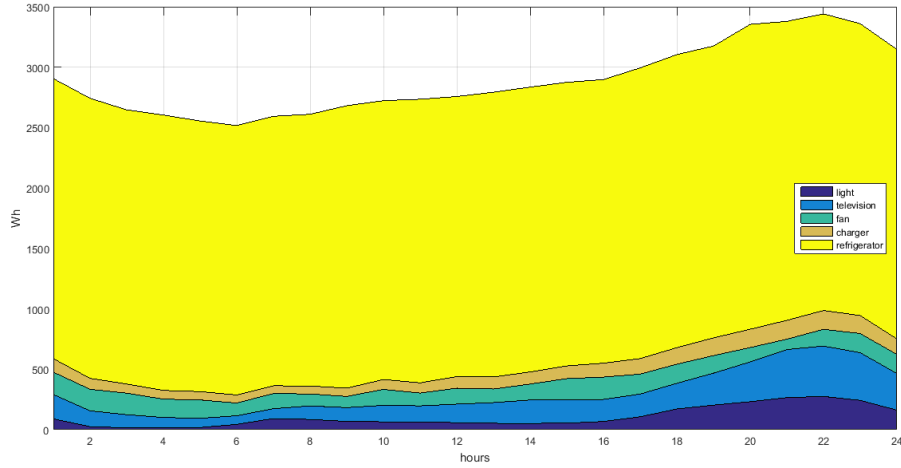

Figure 8: Consumption breakdown of a village with a limited set of appliances, 200 users. Elaboration from [De Almeida et al. (2011)]. Dark blue: lights, Light blue: Television, Green: Ceiling fan, Orange: Mobile charger, Yellow: Refrigerator.

218 with 200 households. Aggregated data of residential consumption are as-  
 219 sumed to be country independent. Since there are no reliable references from  
 220 rural Africa regions, European load profiles were used: this also give the  
 221 opportunities to show single appliances profiles.

222 Daily consumption, for a single house, is 340 Wh, of which 270 Wh is due  
 223 to the refrigerator. Annual total consumption is 124 kWh and the refrigera-  
 224 tor, alone, consumes 100 kWh: thus 80 % of consumption is caused by the  
 225 refrigerator. These values will be used in the next sections as parameters to  
 226 optimize the solar power system and associated storage.

Energy Service	General Info	Daily Use	Daily consumption
Lighting	2 x 300 lm	4 hours	12 Wh
Refrigerator	38.7 liters	24 hours	270 Wh
Television	15.6"	4 hours	22 Wh
Ceiling Fan	19.3 m <sup>3</sup> /min/W	8 hours	16 Wh
Mobile phone charger	2600 mAh	One charge per day	12 Wh

Table 6: User’s energy services. First column shows energy services of the house, second column appliances general information, third column time of utilization and finally daily consumption of each appliances.

227 **6. Design: environment analysis and system optimization for a cost**  
228 **effective solution**

229 The use of renewable energy sources to increase electricity access re-  
230 quires an evaluation based on the available natural resources. Solar resource  
231 needs to be taken into account in the precise location of the new microgrid.  
232 Some of the available solar radiation database are NASA SSE, HelioClim-  
233 1, NCEP/NCAR, World Radiation Data Centre, NREL/USA, SWERA,  
234 SOLEMI, Meteonorm, SolarGIS, SRRI, PVGIS, Climate-SAF PVGIS. There  
235 are some software tools, ususally not free, that could perform generation  
236 analysis starting from one of these database. In the follow system design is  
237 performed in a similar way to other tools and add particular attention to the  
238 trade-off between PV solar power and storage capacity, with the target of  
239 solar home system cost reduction, starting from dataset of solar radiation.

240

241 In particular, the NREL dataset is made up of hourly data of all days  
 242 of the year. For a limited number of locations, radiation data are related to  
 243 ambient temperature. Figure 9 shows a post-processing of the dataset: daily  
 244 irradiance values are shown. Johannesburg was the selected location of the  
 245 analysis. Daily irradiance has wide variations, also in months where it seems  
 246 constant are present falls. Usually, to design PV systems nominal power, it  
 247 is used the average irradiance on the year, but other choices can bring to a  
 248 better solution.

249

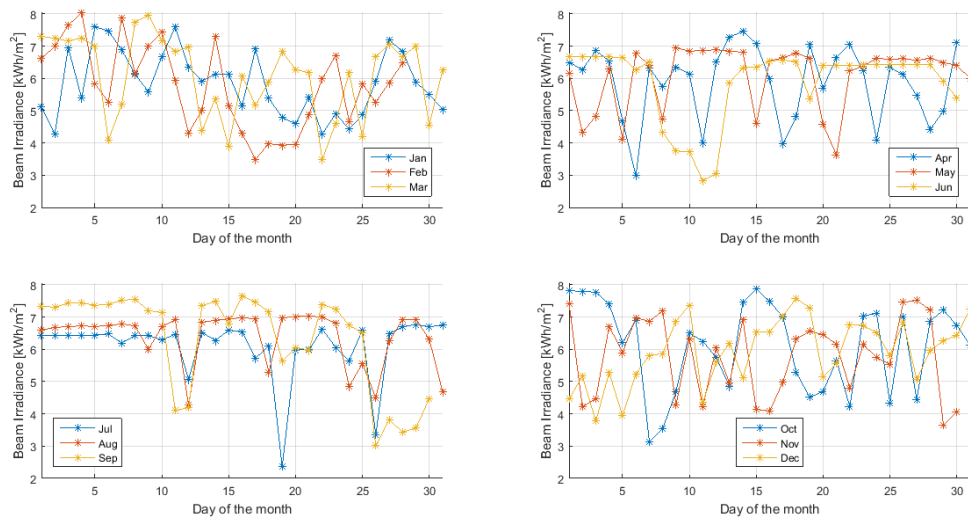

Figure 9: Johannesburg, daily irradiance, all days of the year clustered in months (elaboration from NREL database).

250 In Figure 10 maximum, minimum, median and average values calculated  
 251 based on monthly data, for each month, are shown. The daily absolute  
 252 minimum irradiance is in July,  $2.3 \text{ kWh/m}^2$ , while the absolute maximum

253 is in February,  $8 \text{ kWh}/\text{m}^2$ . The average irradiance is around  $6 \text{ kWh}/\text{m}^2/\text{day}$ .

254

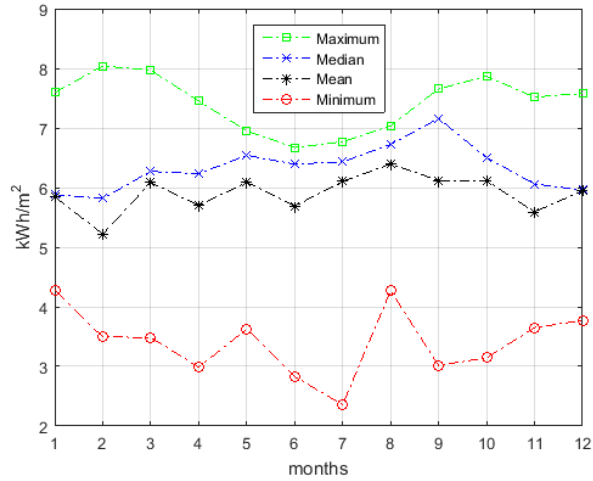

Figure 10: Johannesburg, daily irradiance. For each month maximum, median, average and minimum values are calculated.

255 In order to design the solar home system (1) must be verified: energy  
256 generated from PV panel considering system efficiency must equal or higher  
257 than consumed energy.

$$E_{PV} \cdot \mu \geq E_C \quad (1)$$

258 Produced energy can be directly consumed or stored in batteries and used  
259 later, during night-time or bad weather: in order to correctly design a so-  
260 lar home system, the production/consumption mismatch must be taken into  
261 consideration. With poor design blackout events can occur. Figure 11 shows  
262 the suggest power system block diagram.

263

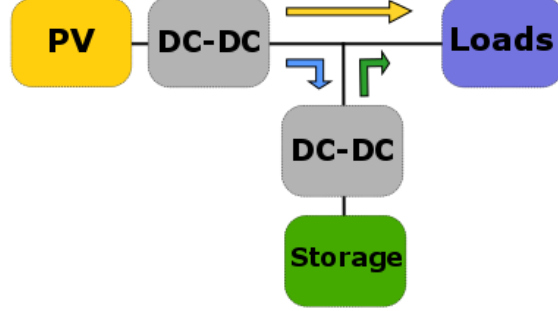

Figure 11: Power system block diagram.

264 The equation (2) defines solar plant nominal power [Z. Sen (2008)] and  
 265 in (3) variable  $\mu_{tot}$  is defined, that is the total daily efficiency, as function  
 266 of simultaneous production and consumption percentage 'd'. During period  
 267  $d$  consumed energy is directly taken from PV panels, while during  $(1 - d)$   
 268 energy is taken from batteries earlier charged [Gandini (2016)].

$$P_N \geq \frac{E_{consumption}}{\mu_{tot}} \cdot \frac{P_{STC}}{G} \quad (2)$$

$$\mu_{tot} = d \cdot \mu_{drt} + (1 - d) \cdot \mu_{drt} \cdot \mu_{stg} \quad (3)$$

269 Where 'G' is the irradiance, ' $P_{STC}$ ' is the power in standard test condition  
 270 equal to  $1 \text{ kW}/\text{m}^2$  and ' $E_{consumption}$ ' is the daily energy consumption. ' $\mu_{drt}$ '  
 271 is the system efficiency in case of simultaneous production and consumption  
 272 and ' $\mu_{stg}$ ' is the storage round-trip efficiency, including its own power con-  
 273 verter. Due to system design, daily total efficiency is a combination of these  
 274 two efficiencies.

275

276 In Table 7 assumed efficiencies are reported. Temperature efficiency, that  
 277 models the reduction of generated power introduced by high ambient tem-  
 278 perature, is an average value calculated from temperature profiles of NREL  
 279 database. Converters' efficiencies are derived from the use of newest power  
 280 semiconductor technologies.

281

Efficiencies	
Temperature	0.98
MPPT	0.99
PV converter	0.97
Wire & Connections	0.95
Storage	0.95
Storage Round trip	0.90
Storage converter	0.96

Table 7: Estimated system's efficiencies

282 Table 8 shows the variation of daily total efficiency, when changing simul-  
 283 taneous production/consumption percentage according to equation (3) and  
 284 data of Table 7. This percentage changes with users consumption behavior.

285

286 Table 9 shows solar PV nominal power, calculated according to (2), chang-  
 287 ing daily irradiance and simultaneous production/consumption percentage.  
 288 Using as irradiance the absolute daily minimum, in column two, the largest  
 289 nominal power is obtained: this approach is the most conservative, leading to  
 290 an oversizing of the solar power plant. On almost all days of the year, there

d	$\mu_{tot}$
10%	0.7939
20%	0.8050
30%	0.8161
40%	0.8273
50%	0.8384

Table 8: Equivalent total efficiency variation with different direct consumption percentage

$P_N(d, G)$	Abs max G 8 kWh/m <sup>2</sup>	Abs min G 2.4 kWh/m <sup>2</sup>	Avg G 6.3 kWh/m <sup>2</sup>
d = 10%	53 W	178 W	67 W
d = 20%	52 W	176 W	66 W
d = 30%	51 W	174 W	65 W
d = 40%	51 W	171 W	64 W
d = 50%	50 W	169 W	63 W

Table 9: Minimum nominal power of solar PV changing percentage of direct consumption and daily irradiance.

291 is an energy over production, which is in excess of household consumption.

292

293 Because of during period  $(1 - d)$  consumed energy is taken from battery  
 294 equation (4) is used to find the minimum energy storage capacity necessary to  
 295 always supply loads; where DOD is the depth of discharge, which is necessary  
 296 to avoid safety problems and to increase battery lifetime, around 30%.

$$E_{storage} \geq E_{consumption} \cdot (1 - d) \cdot [1 + \min(DOD)] \quad (4)$$

297 In order to increase reliability an analysis over a whole year was per-  
 298 formed. Figure 12 shows the daily overproduction (total production minus  
 299 household consumption considering system's efficiencies) for each month and  
 300 day of a year. System's parameters are 95 W of PV nominal power, a storage  
 301 capacity of 300 Wh, calculated by (4) and the energy consumption obtained  
 302 in section (5). Values under zero are black out events.

303

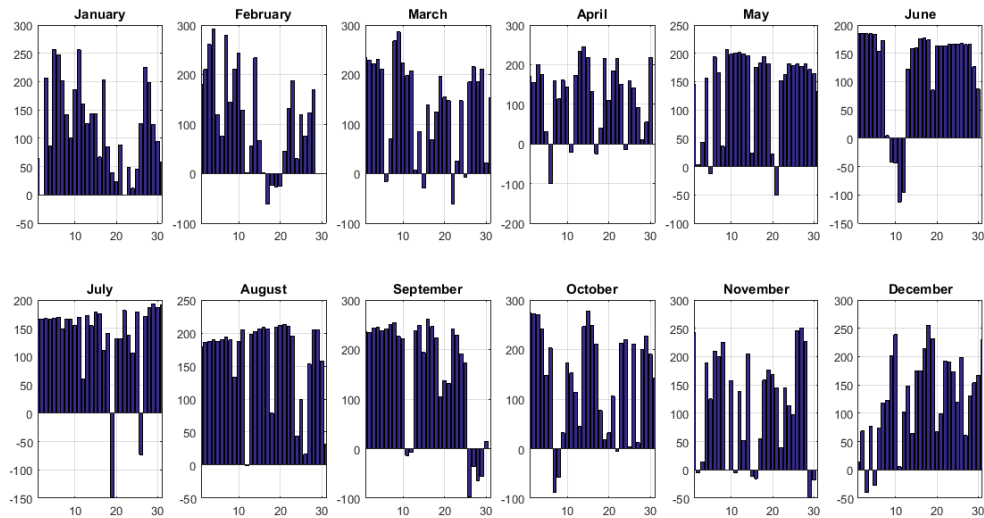

Figure 12: Energy overproduction (Wh), in Johannesburg. PV nominal power: 95 W. Storage capacity: 300 Wh. X axis are days. Y axis are energies [Wh].

304 Black-out events occurs because equation (4) is true only in case of PV  
 305 nominal power calculated using the absolute minimum irradiance, column  
 306 two of Table 9. In order to design a storage system with other PV nominal

307 powers and avoid black-out events it is necessary to add a correction factor,  
 308 equation (5) is the generalized formula to design storage capacity with dif-  
 309 ferent PV nominal powers to ensure energy continuity. ' $E_{blackout}$ ' is the daily  
 310 missing energy. Over the year the maximum missing energy of consecutive  
 311 days is taken. For each PV nominal power it is simulated the over/under pro-  
 312 duction using a storage sized with (4), then consecutive black-out events are  
 313 identify and it is considered the maximum missing energy. In this particular  
 314 simulation, the worst case is in June, as shown in Figure 13.

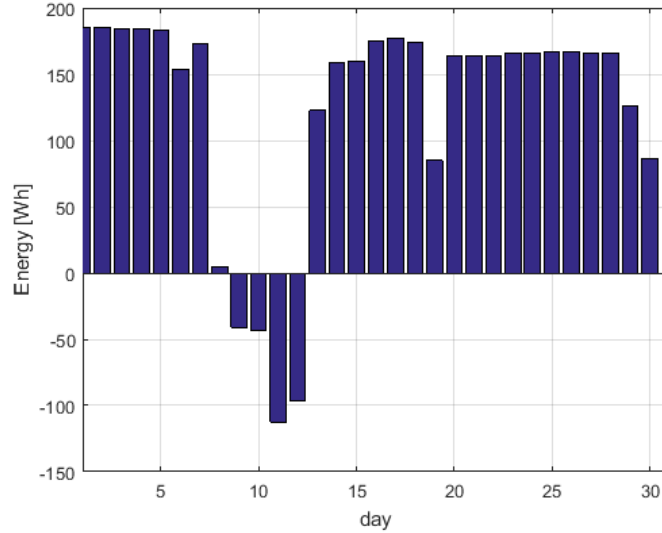

Figure 13: Energy overproduction (PV nominal power 95 W, storage capacity 300 Wh), in June. Each bar represents a day. Greatest event of consecutive blackouts of the year.

$$E_{storage} \geq E_{consumption} \cdot (1 - d) \cdot [1 + \min(DOD)] + \max \left( \sum_i E_{blackout,i} \right) \quad (5)$$

315 The sum of consecutive missing energy daily values, in June, is 350 Wh.

316 Therefore with a PV nominal power of 95 W and a storage of 650 Wh, con-  
317 sidering daily irradiance data from NREL and consumption of Table 6, black  
318 out events are avoided. With an adequately designed battery, it is possible  
319 to store energy over produced in days before the critical period, and then use  
320 it in low irradiance days. In case of the storage being completely charged,  
321 it is possible to use the energy excess to supply ancillary services as water  
322 pumps and water purification systems.

323

324 Figure 14 shows the relation between solar PV nominal power, storage  
325 size and monthly cost of energy. Energy cost is based on the amortization of  
326 system considering life time. Included costs are PV module [Bloomberg NEF  
327 (2015)], storage [Nykvist & Nilsson (2015)] and power electronics equipment  
328 (converters, balancer, installation) as a percentage of module and storage  
329 costs. The estimated lifetime of all system is conservatively assumed to be 10  
330 years. Because of NREL dataset has an uncertainty of 10 %, it is still possible  
331 the occurrence of electricity interruptions, but one day of interruption means  
332 99.7 % of guaranteed service. Designing solar power systems in such a way  
333 to minimize storage size, as the use of minimum irradiance over the year to  
334 calculate PV nominal power, is the most cost effective solution. Monthly  
335 cost of energy is in all design options less than 8 USD. Values under 5 USD  
336 can be an affordable cost also for households in poor areas.

## 337 **7. Conclusions and recommendations**

338 Electricity access is still a dream for around 20 % of world population and  
339 Sub-Saharan Africa has more people living without access to electricity than

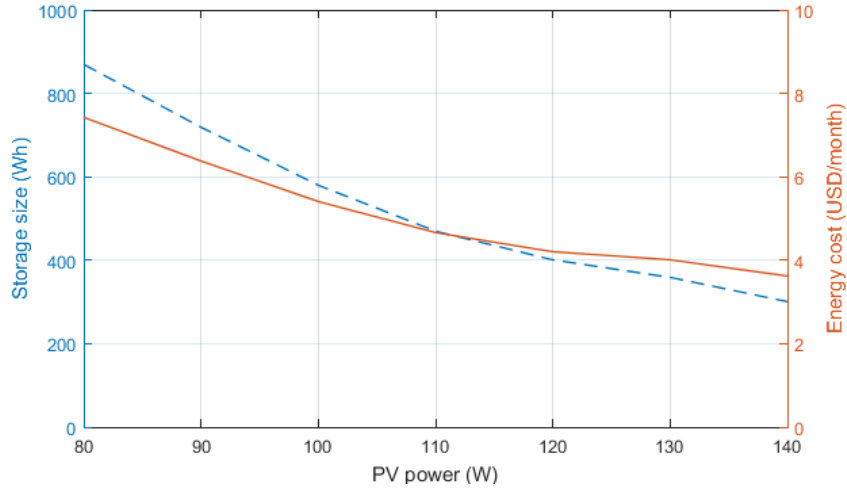

Figure 14: On left axis storage sizing function of PV nominal power in order to avoid black out, on right axis energy cost per month. Estimated system life-time 10 years. Cost of energy is function of PV nominal power and storage size.

340 any other World region. Traditional approaches to electrify rural areas imply  
 341 capital intensive infrastructures and large investments. DC microgrids, based  
 342 on renewable sources and storage systems, can be easily implementable and  
 343 lead to cost effective solutions.

344

345 The use of super efficient appliances can dramatically reduce the house-  
 346 holds electricity consumption, leading to smaller and cheaper systems. An  
 347 analysis of the use of efficient DC appliances performed by simulation of  
 348 household consumption with an approach oriented to give basic energy ser-  
 349 vices, was carried out. The design of a solar home system can be achieved  
 350 by analysis of irradiation variation during a complete year, and the required  
 351 load, finding the most cost effective solution. Rural electrification can be

352 a win-win challenge: improve quality of life of millions of people in a sus-  
353 tainable way. Moreover, it can be a future important market as shown by  
354 new companies, active in this field, leading also to local employment in the  
355 installation and maintenance of these distributed clean energy systems.

## 356 **References**

357 IEA, *World Energy Outlook*, 2014

358 IEA, *Africa Energy Outlook*, 2014

359 World Health Organization (WHO), *World Health statistics*, 2014

360 D. Schnitzer, D. S. Lounsbury, J. P. Carvallo, R. Deshmukh, J. Apt and D. M.  
361 Kammen, *Microgrids for rural electrification*, United Nations Foundation,  
362 February 2014.

363 P. Waide and M. Scholand, *The potential for global energy savings from high*  
364 *efficiency distribution transformers*, Waide Strategic Efficiency Limited  
365 and N14 Energy Limited, 2014.

366 A. Eide, N. Borg and E. Toulouse, "Comments on Eup Study: Lot 2 Distri-  
367 bution and Power Transformers," CLASP Europe, 2010

368 K. E. Knapp, J. Martin, S. Price and F. M. Gordon, *Costing methodology for*  
369 *electric distribution system planning*, The Energy Foundation, November  
370 9, 2000.

371 S. Mehta, *PV Technology, Production and Cost Outlook*, GMT, 2013.

372 Fraunhofer Institute for Solar Energy System, *PHOTOVOLTAICS REPORT*,  
373 Freiburg, 2016.

374 Bloomberg New Energy Finance, *New Energy Outlook 2015*, 2015.

375 Ran Fu, Donald Chung, Travis Lowder, David Feldman, Kristen Ardani,  
376 and Robert Margolis *U.S. Solar Photovoltaic System Cost Benchmark:*  
377 *Q1 2016*, NREL, 2016.

378 D. Boucar and P. Ramchandra, *Potential of lithium-ion batteries in renewable*  
379 *energy*, Renewable Energy, vol. 76, pp. 375-380, April 2015.

380 B. Nykvist and M. Nilsson, *Rapidly falling costs of battery packs for electric*  
381 *vehicles*, Nature climate change, vol. 5, no. 4, pp. 329-332, 2015.

382 J. Morris, *Helping Battery Cost Declines Keep Going and Going*, Rocky  
383 Mountain Institute, 2014.

384 IRENA, *Battery storage for renewables: market status and technology out-*  
385 *look*, 2015.

386 A. Phadke, A. Jacobson, W. Y. Park, G. R. Lee, P. Alstone and A. Khare,  
387 *Powering a home with just 25 Watts of solar PV*, Berkeley Lab, April 2015.

388 R. L. Hwang, M. J. Cheng, T. P. Lin and M. C. Ho, *Thermal perceptions,*  
389 *general adaptation methods and occupant's idea about the trade-off between*  
390 *thermal confort and enegy saving in hot-humid regions*, Build and Envi-  
391 ronment, 2009

392 S. de la Rue du Can, V. E. Letschert, M. A. McNeil, N. Zhou and J. A.  
393 Sathaye, *Residential and Transport Energy Use in India: Past Trend and*

- 394 *Future Outlook*, Berkeley CA: Lawrence Berkeley National Laboratory,  
395 2009
- 396 N. Shah, N. Sathaye, A. Phadke and V. Letschert, *Cost and benefits of effi-*  
397 *ciency improvement in ceiling fans*, EEDAL, 2013
- 398 L. Desroches and K. Garbesi, *Max Tech and Beyond: Maximizing appliance*  
399 *and equipment efficiency by design*, LBNL, 2011
- 400 J. R. Burkart, *Comparative Evaluation of SiC and Si PV Inverter Systems*  
401 *Based on Power Density and Efficiency as Indicators of Initial Cost and*  
402 *Operating Revenue*, COMPEL, 2013
- 403 J. Liu, K. L. Wong, S. Allen and J. Mookken, *Performance Evaluations of*  
404 *Hard-Switching Interleaved DC/DC Boost Converter with New Generation*  
405 *Silicon Carbide MOSFETs*, Cree Inc, 2013
- 406 EU, *Directive 2009/125/EC*, European Parliament and of the Council, 21  
407 October 2009.
- 408 I. P. Tsoumas, H. Tischmacher and P. Kollensperger, *The European Standard*  
409 *EN 50598-2: Efficiency classes of converters and drive systems*, Electrical  
410 Machines (ICEM), 2014
- 411 T. Sanchez, *The Hidden Energy Crisis: How policies are failing the worlds*  
412 *poor*, London: Practical Action Publishing, 2010
- 413 ESMAP, *Beyond connections - Energy Access redefined*, The world bank  
414 group, Washington DC, 2015

- 415 Global LEAP, *Off-Grid appliance market survey*, 2015
- 416 A. de Almeida, P. Fonseca, N. Feiberg and B. Schlomann, *Characterization of*  
417 *the household electricity consumption in the EU, potential energy savings*  
418 *and specific policy recommendations*, Energy and Building, vol. 43, no. 8,  
419 pp. 1884-1894, August 2011
- 420 L.C. Kelley, E. Gilbertson, A. Sheich, S.D. Eppinger, S. Dubowsky, *On the*  
421 *feasibility of solar-powered irrigation*, Renewable and Sustainable Energy  
422 Reviews 14, pp. 2669-2682, 2010
- 423 Zekai Sen, *Solar Energy Fundamentals and Modeling Techniques* London:  
424 Springer-Verlag, 2008, pp. 102-103.
- 425 De Almeida, A., Santos, B., Martins, F., 2016. Energy-efficient distribution  
426 transformers in europe: impact of ecodesign regulation. Energy Efficiency  
427 9 (2), 401–424.
- 428 Gandini, D., 2016. Energy storage as enabling technology for smart grid.  
429 Ph.D. thesis, Politecnico di Torino.