

Life Cycle Assessment (LCA) of biogas-fed Solid Oxide Fuel Cell (SOFC) plant

Original

Life Cycle Assessment (LCA) of biogas-fed Solid Oxide Fuel Cell (SOFC) plant / Rillo, E., Gandiglio, M., Lanzini, A., Bobba, S., Santarelli, M., Blengini, G.A.. - In: ENERGY. - ISSN 0360-5442. - 126:(2017), pp. 585-602.
[10.1016/j.energy.2017.03.041]

Availability:

This version is available at: 11583/2667503 since: 2018-01-19T14:22:46Z

Publisher:

Elsevier Ltd

Published

DOI:10.1016/j.energy.2017.03.041

Terms of use:

This article is made available under terms and conditions as specified in the corresponding bibliographic description in the repository

Publisher copyright

Elsevier postprint/Author's Accepted Manuscript

© 2017. This manuscript version is made available under the CC-BY-NC-ND 4.0 license
<http://creativecommons.org/licenses/by-nc-nd/4.0/>. The final authenticated version is available online at:
<http://dx.doi.org/10.1016/j.energy.2017.03.041>

(Article begins on next page)

Life Cycle Assessment (LCA) of biogas-fed solid oxide fuel cell (SOFC) plant

E. Rillo^a, M. Gandiglio^{a,*}, A. Lanzini^a, S. Bobba^b, M. Santarelli^b, G. Blengini^b

^a *Department of Energy, Politecnico di Torino, Italy*

^b *Department of Environment, Land and Infrastructures Engineering, Politecnico di Torino, Italy*

* Corresponding author: Marta Gandiglio, Department of Energy, Politecnico di Torino.
marta.gandiglio@polito.it; +39 011 0904560

Abstract

The Life Cycle Assessment (LCA) of biogas-fed Solid Oxide Fuel Cell (SOFC) integrated with a CO₂ recovery system is presented in this work. The goal of the work is to evaluate the environmental performance of an SOFC fueled with sewage biogas and to compare it with traditional technologies (internal combustion engines and microturbines) using the same fuel. CO₂ recovery is performed through a tubular photobioreactor, fixing the recovered carbon in the form of a micro-algae.

The analysis takes into account both the biogas production line (anaerobic digester) and its exploitation into the fuel cell (i.e., the power generator).

Results show that the SOFC manufacturing activity is highly intensive since it requires a large amount of use of electricity. During operation, instead, the highest burden is associated with the fuel production. We analyzed two scenarios for biogas operation underlining the benefits of introducing sludge pre-thickening before the anaerobic digestion process. The use of a sludge pre-thickening system can reduce the inlet flow of natural gas into the plant, thus affecting the fuel chain contribution and reducing the overall impact.

The photobioreactor results in consuming more energy than what it produces (looking at the operation phase only; the manufacturing phase was not even included) and being responsible for more carbon emissions than the amount fixed in algae. On the other side, data for the photobioreactor system were based on a real system at the proof-of-concept level. Therefore significant improvements are expected for an industrial-size system.

Finally, the SOFC environmental burdens have been compared with main competitors in the same field (internal combustion engines and microturbines), showing the superior environmental performance. The proposed energy system is thus an interesting choice for cleaner energy production.

Nomenclature

AD	Anaerobic Digester
CCS	Carbon Capture and Storage
CCU	Carbon Capture and Utilization
CHP	Combined Heat and Power
FC	Fuel Cell
ICE	Internal Combustion Engine
GT	Gas Turbine
LCA	Life Cycle Assessment
LCI	Life Cycle Inventory
LCIA	Life Cycle Impact Assessment
LCT	Life Cycle Thinking
MT	Micro Turbine
NG	Natural Gas
PBR	PhotoBioReactor
S/C	Steam to Carbon
SOFC	Solid Oxide Fuel Cell
TSS	Total Suspended Solid
WWTP	Wastewater Treatment Plants

1. Introduction

Solid Oxide Fuel Cell (SOFC) systems represent an alternative solution to conventional power generation systems [1].

A very interesting opportunity is the integration of this technology in Wastewater Treatment Plants (WWTP). Biogas available from the Anaerobic Digestion (AD) of biomass is indeed a fuel for the SOFC [2–4].

Also, in energy plants, large importance is assigned, especially in EU, to the opportunities of CO₂ management (recovery and re-utilization). Then, a further possibility is to integrate the system with a process of CO₂ recovery and Carbon fixing: a CO₂ recovery system based on a photobioreactor (PBR) for algae growth.

The described system has been developed as a proof-of-concept in the framework of the next EU projects:

- SOFCOM project (2011-2015), an EU project aimed to prove the technical feasibility and the environmental benefits of CHP systems based on SOFC technology fed with different varieties of biofuels and with CO₂ capture and re-use in a PBR for algae growth. The project was related to both techno-economic modeling activities and two proof-of-concept installations. (www.sofcom.eu) [5,6]. The SOFCOM concept, mainly related to the closed Carbon cycle using CO₂ capture, is shown in Figure 1.
- DEMOSOFC project (2015-2020), another EU project related to the scaled-up concept of SOFC installation in large size biogas plants. In its framework, a 174 kW_e will be installed in a WWTP in Torino (www.demosofc.eu). The project concept is described in Figure 1.

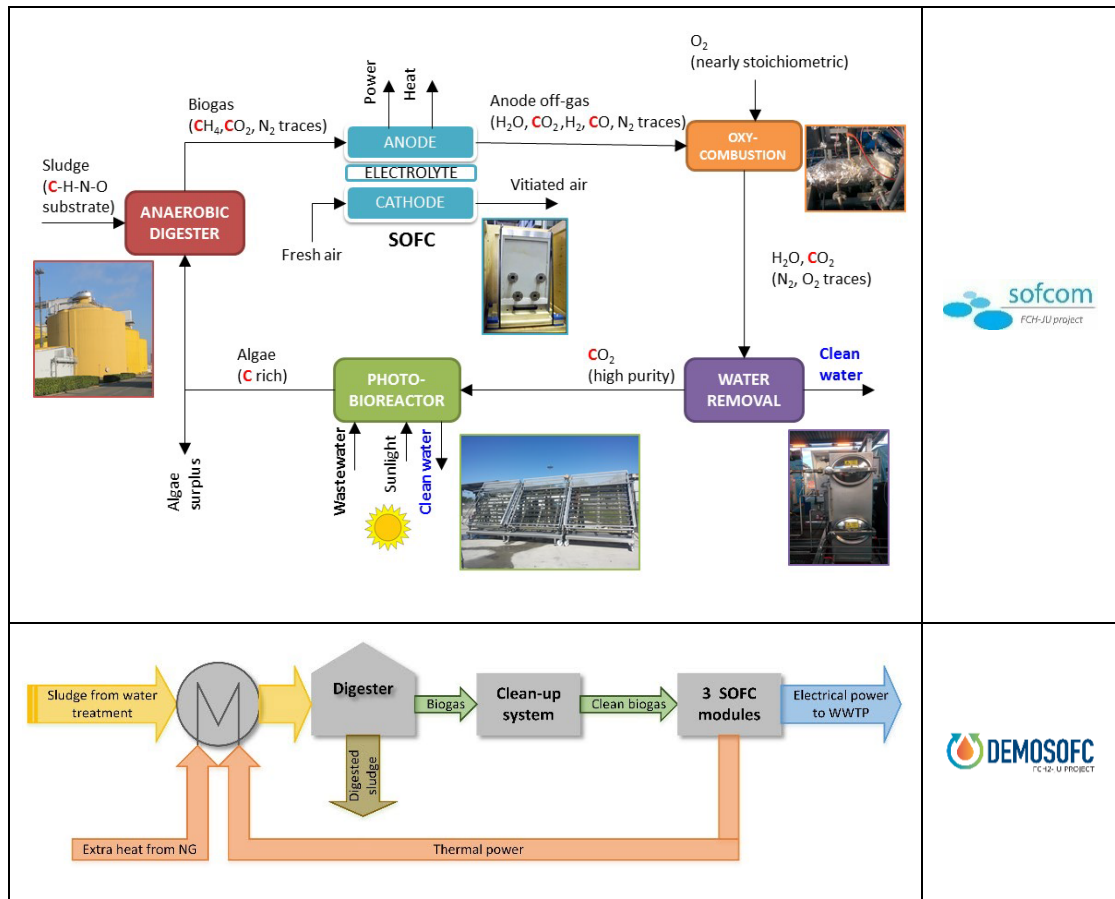

Figure 1. SOFCOM and DEMOSOFC plant concept.

Biogas-fed SOFC systems offer the possibility to reduce emissions regarding CO₂ drastically, NO_x and SO_x compared to internal combustion engines. However, a broader environmental assessment is required to fully understand the impact of SOFC and its application with a given fuel. Life Cycle Assessment (LCA) is a well-established methodology to evaluate the environmental performance of a system in a large-view approach through all its lifetime, from the raw material to the final equipment disposal.

Recent literature on the LCA of fuel cell systems focuses on the manufacturing phase. Several works take into account Molten Carbon Fuel Cells (MCFC) since the technology is now available on the market [7–9]. It is pointed out by Mehmeti et al. [9] that MCFC environmental performance is strongly influenced by the use of non-renewable energy and material demand of metals and rare earth elements which generate high environmental loads in the manufacturing stage.

Other fuel cell systems life cycle analysis can be found for FC vehicles [10–12], auxiliary power systems onboard ships [13] and some more recent studies on SOFC for distributed

power generation, where both natural gas and biogas fed SOFC systems are analyzed [14–17]. In this work, when NG is the feeding stream, fuel supply is responsible for a relevant share of the environmental impact, while if the same system is fed with biogas, environmental benefits on global and regional impact categories, depending on the power energy mix used during the digestion are shown.

In [18] biomass-based energy systems are analyzed for Denmark with LCA methodology and results showed that greenhouse gas emissions per energy supplied could be significantly reduced (from 68 to 17 Gg CO₂ eq./PJ) by the increased use of the wind and residual biomass resources as well as by electrifying the transport sector.

In terms of feeding fuel, biogas production via AD has been already widely analysed from an environmental point of view [19–23]; most of the available works are related to biogas with a high solid content, as agricultural residuals, dairy farms manure and organic fraction of municipal solid wastes (OFMSW). Compared to other types of biogas, the one from WWTP, due to its low solid content, requires a higher specific energy supply (kWh per ton of solid biomass treated), thus leading to higher environmental impacts compared to other types of biogas. Despite this issue, AD is pointed out as an environmentally effective process: in [24], LCA shows that the AD plant fed by vinasse as input biomass could improve the environmental performance with respect to the lagoon of vinasse, reducing up to 77% the total score (sum of the endpoint scores, where studied endpoint impact categories were “ecosystem quality”, “human health” and “natural resources) and recovering up to 46% of the exergy extracted from the natural environment during the process, respectively. Also in the case of OFMSW, AD emerges as the best treatment option regarding total CO₂ eq. and total SO_{2,eq} saved, when energy and organic fertilizer substitute non-renewable electricity, heat and inorganic fertilizer [19].

In [25] the comparison among MCFCs, ICEs, and MTs is performed from a techno-economic point of view, analyzing both systems fed with biogas from WWTP: the fuel cell system shows the highest technical performance, improving the electrical self-sufficiency of the WWTP around 60% compared to conventional cogeneration.

An interesting comparison among various biogas fed CHP systems is also performed in [23], where fuel cells are compared to ICEs and biogas upgrading and are pointed out as the solution with the best environmental performances, followed by internal combustion engines

and the by bio-methane production. However, when thermal energy is not recovered, the differences on the bio-methane case are strongly reduced [23]. The mentioned study, anyway, does not take into account the manufacturing process for both CHP systems and AD plants, which are considered in the present work.

In [22], the environmental impacts of using biogas produced from OFMSW to supply energy to a group of dwellings, using SOFC micro-CHP systems and condensing boilers, is also analyzed. A net saving of ~130 tons of CO₂ eq. per year per dwelling is achievable compared with the reference scenario, confirming the environmental advantage of SOFC systems.

The present work aims to couple the AD environmental analysis with a high-efficiency CHP system using SOFC to produce electricity and heat. Also, a further component is included in the systems and thus in the analysis: a CO₂ recovery system based on a photobioreactor (PBR) for algae growth. Even if algae are considered a fast-growing biomass and studied as a potential optimal biofuels source for the future, the environmental analysis still points out many issues to be solved: in [26] final results show that algal biodiesel produced through current conventional technologies has higher energy demand and greenhouse gas emissions than fossil diesel. From an energy point of view, as stated in [27], neither open raceway pond nor PBR wet and dry routes yields positive energy balance. Even with the best possible route (open raceway pond dry route), the total energy use is almost 5 times more than the energy produced [27] [28].

The present work will analyze innovative SOFC system [17]; moreover, this phase will be coupled with the SOFC operation in biogas AD plants. A parallel analysis is also performed, taking into account not only technical and economic performance but also the environmental impact of the available CHP solutions. The goal is to evaluate the environmental performance of SOFC systems fueled with WWTP biogas and to prove its effectiveness in respect to conventional technologies, such Gas Turbines (GT) and Internal Combustion Engines (ICE). The environmental analysis will take into account both the manufacturing and the operation stage, thus leading to a wide view of the entire system.

The novelty of the present work is summarized as follows:

- an innovative industrial-size biogas-fed SOFC system has been analysed. The baseline scenario reflects the real installation undergoing in the DEMOSOFC project ([29–31]), while the carbon capture process draws on the proof-of-concept plant

developed in the framework of the SOFCOM project [5]. This is the first time, to the best of the authors' knowledge, that the LCA approach has been applied to such type plant.

- we have matched data available from the Ecoinvent® database with real data available from the operations of the SOFC plant in a wastewater treatment plant .

2. Plant layout and Methodology

2.1 Plant layout

The design concept for the present study was derived from the SOFCOM proof-of-concept, designed and operated in Torino. A 2 kW_e biogas-fed SOFC system with carbon capture and re-use in a PBR for algae growth are key characteristics of the SOFCOM plant [32]. The SOFCOM system is a proof-of-concept plant which has demonstrated the feasibility of CCU using SOFC, while the new DEMOSOFC project (2015-2020) is related to a real industrial fuel cell installation in a WWTP in the Torino premises.

From this initial concept, the LCA is performed about a plant of larger size which is representative of a real industrial-scale installation (as being developed in the DEMOSOFC project). Then, the reference size of the power unit (SOFC) is chosen as 250 kW_e, accordingly to the requirements of a WWTP plant serving a small-medium municipality.

To describe the process of energy generation from the SOFC system, and to show the principal material flows and components of the SOFC system, a process layout is presented in Figure 2.

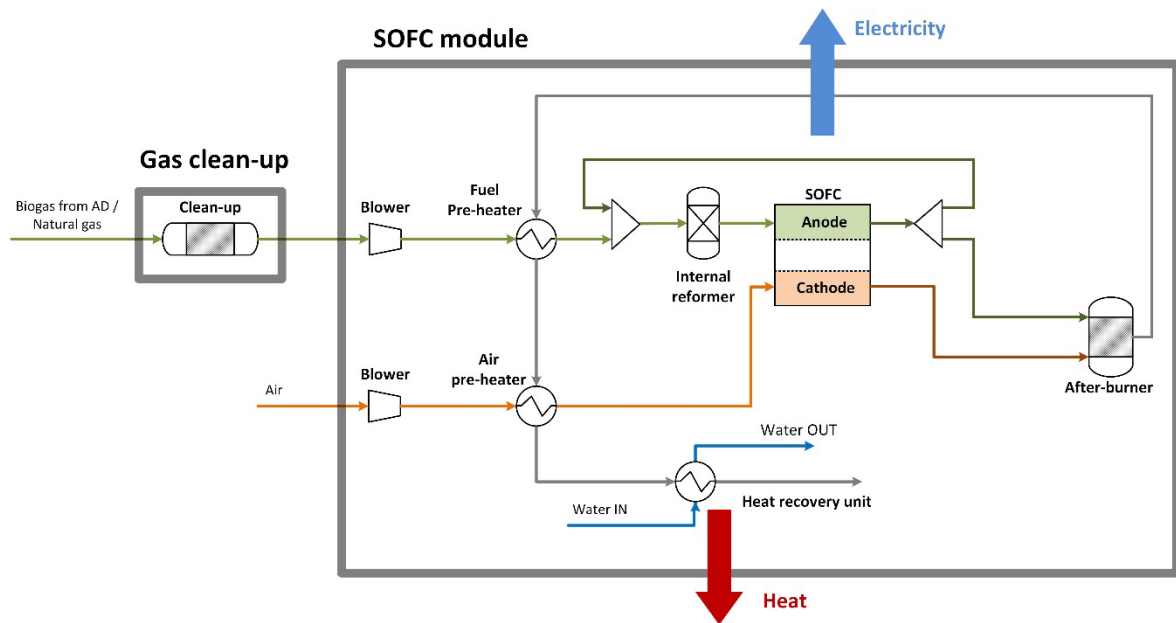

Figure 2. System diagram of medium size SOFC installation [33].

The analysis is indeed aimed at evaluating the environmental burdens of the technologies involved, also considering their competitiveness on the market. Instead, regarding primary data, information from scale-up studies, personal communications from technicians in the facility, literature and, if necessary, own estimations and calculations are preferred. Looking at the main flows of materials, a description of the operation of the system here follows:

- Fuel/flue gas line (green): the biogas from the AD is fed to the system by a compressor, and then pre-heated by flue gas in the fuel pre-heater. Before entering the reforming zone, the heated fuel is mixed with a recirculated fraction of the anode exhaust in order to provide the required S/C ratio. The steam reforming reaction takes place in an indirect internal reactor, where the endothermic steam reforming reaction is sustained by the high SOFC operating temperature. At the anode of the SOFC stack, the reformed fuel is oxidized, producing electricity. In the after-burner, the remaining fuel is burned with spent air, in order to avoid fuel emissions and to raise the temperature of the flue gas. The flue gas provides then the heat necessary to the pre-heating of fuel and air; lastly, it provides the heat for water heating (HRU);
- Air supply line (red): air is fed through a compressor, then it is pre-heated and fed to the cathode of the SOFC stack, where oxygen provides the oxidant for the electrochemical reactions. The air is then sent to the after burner, merging with the exhaust fuel into the flue gas.

- Water supply line (blue): demineralized water is introduced and mixed with the fuel to guarantee the correct S/C ratio for the reforming during the start-up phase when the components need to raise their temperatures to the operative levels. Lastly, in the HRU loop, water is heated and sent to the thermal user (AD).

More details about the single components, technical and operational data are presented in the LCI section.

The presented plant layout will be analyzed in different configurations by including a sludge pre-thickening system on the biomass entering the digester (in the case of biogas feeding), and by recovering the CO₂ from the SOFC exhaust.

2.2 Methodology

In the framework of Life Cycle Thinking (LCT), LCA is a well-established tool for the assessment of environmental burdens. ISO standards 14040 and 14044 give framework and guidelines for practitioners [34,35]. The environmental analysis is carried performing a Life Cycle Assessment (LCA) of such system. LCA model and calculations have been performed with SimaPro® (www.pre-sustainability.com) v.7.3.3., using the commercial database Ecoinvent® v.2.2.

The goal of this LCA is to investigate the environmental performance of SOFC technology fueled with biogas locally produced from sewage sludge. The chosen design for SOFC technology is planar rectangular cells.

The study should prove the validity of the technology as a feasible alternative to the traditional technologies for energy recovery from biogas such as ICE and GT, competitive both from a technical (high efficiencies) and an environmental point of view, producing very low environmental burdens. For small scale power units (<1MWe), the SOFC has the advantage of maintaining high efficiencies, while engines and turbines provide poor performance if compared to large size plants.

The functional unit is 1 kWh of electricity as produced by the SOFC system.

The system boundaries include biogas production, SOFC manufacturing, operation, and maintenance. A “cradle-to-gate” approach is used; hence, end-of-life is not included in the study. Transportation within system boundaries is not included, both for lack of information about the distances.

Figure 3 displays foreground processes with internal exchanges and also the exchanges with nature (emissions) and technosphere (energy and materials inputs, the output of final product).

The system is also a poly-generation plant since the SOFC works in CHP configuration. Allocation is therefore used to distribute the environmental burdens among each product. Allocation factors are calculated by the exergetic content of the energy flows. (according to “*Life Cycle Assessment Guidance for Fuel Cells and H₂ Technologies*” and the ILCD Handbook [36]).

Inventory analysis is carried following attributional modeling approach. The main source of foreground data is previous work related to SOFCOM project, literature information and personal communications from qualified experts and practitioners. Background data is taken from Ecoinvent® database, version 2.2 (www.ecoinvent.ch).

Whenever possible, primary data is used for modeling foreground processes; the rest is provided as secondary data. For background processes, secondary data is always used.

For the analysis of the potential environmental impacts, ReCiPe Midpoint v1.06 method is used [37]. Among the ReCiPe impact categories, those chosen to suitably represent the environmental profile of electricity generation from SOFC technology are the following: climate change, fossil depletion, terrestrial acidification and Photochemical oxidant and particulate matter formation. In order to include also emissions of biogenic carbon (such as the emissions from biofuels), separate calculations are performed for GHG emissions. Thus more comprehensive information about GHG emissions is provided.

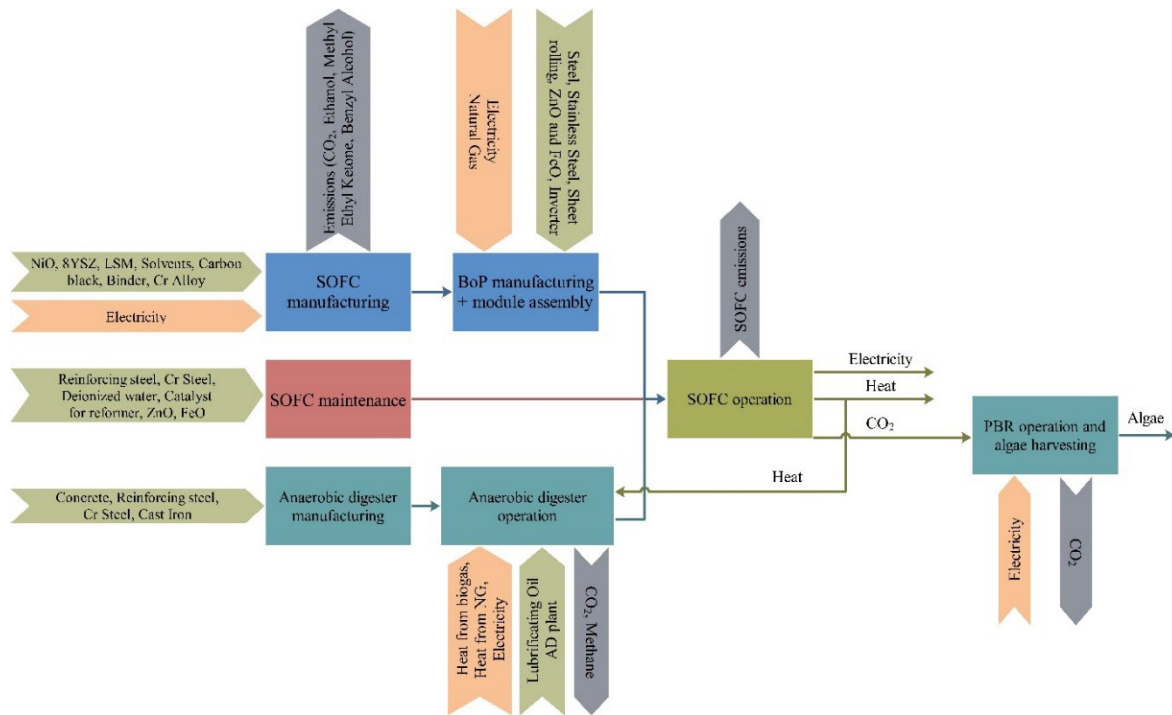

Figure 3. Foreground processes

3. Life cycle inventory

The life cycle inventory has been developed for each one of the different life-phases described above, and it has been applied to each one of the following three scenarios:

- **Scenario 1:** 250 kWe SOFC system fed by Natural Gas from the grid. This will be considered as a benchmark SOFC scenario to underline the main advantages related to the use of biogas as a fuel.
- **Scenario 2:** 250 kWe SOFC system fed by biogas from WWTP. This is the scenario related to the DEMOSOFC installation, which will be analyzed in the current layout and with a system improvement related to the sludge thickening.
 - **Scenario 2.1:** Current AD system without sludge pre-thickening (TSS 1.91%): in the available WWTP layout sludge solid content is very low with a related high thermal demand for the sludge flow heating compared to the organic matter contained. A commercially available solution for reducing the water percentage and thus the heat demand is the use of a dynamic or centrifugal sludge pre-thickening.
 - **Scenario 2.2:** Future AD system with sludge pre-thickening (TSS 5%).

- Scenario 3:** 250 kW_e SOFC system fed by biogas from WWTP with carbon capture and use (CCU). Based on the SOFCOM concept, the CO₂ capture and reuse through a photobioreactor has been analyzed.

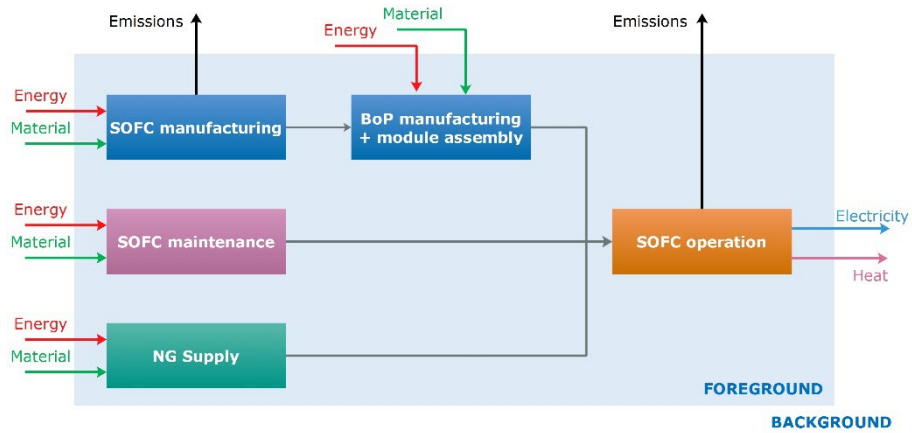

Figure 4. NG fed SOFC system (scenario 1)

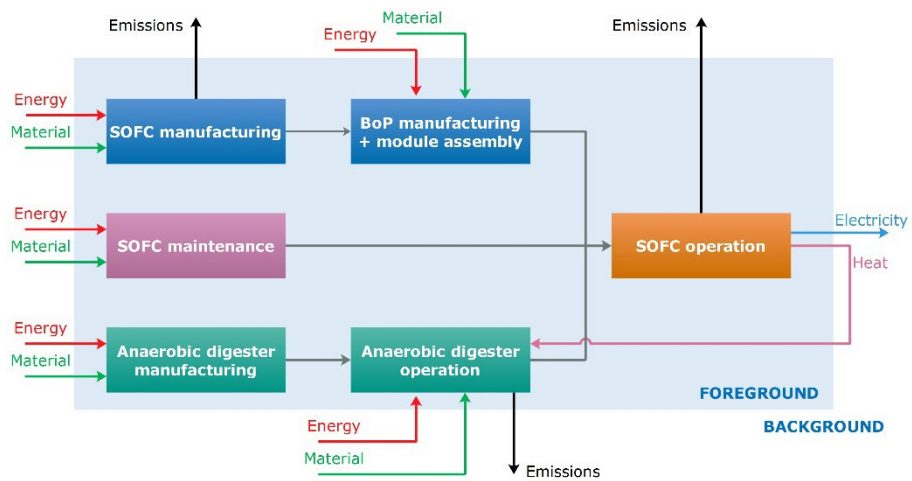

Figure 5. Biogas fed SOFC system (scenario 2)

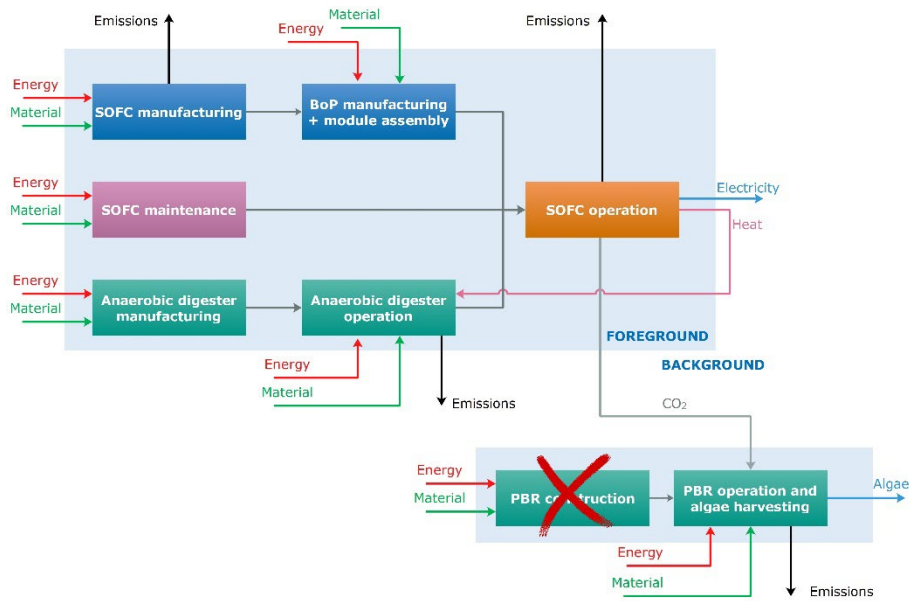

Figure 6. Biogas fed SOFC with CCU (Scenario 3).

For what concerning the fuel cell, the inventory includes:

- SOFC system manufacturing
 - SOFC stack manufacturing
 - SOFC BoP manufacturing and system assembly
- SOFC operation
- SOFC maintenance

The fuel chains have also been analyzed: natural gas is already included in the Ecoinvent® database, while update models related to the SMAT WWTP have been used for the biogas chain. In particular:

- Natural gas
- WWTP biogas
 - AD digester construction
 - AD digester operation

Finally, the CO₂ capture system is analyzed, accounting only for the operation stage and neglecting the impacts related to the manufacturing.

All the inventory structure and results are available in Appendix A.

4. Life Cycle Impact Assessment (Results)

Before illustrating the LCIA results concerning the functional unit of this LCA (i.e. 1 kWh of electricity as produced by the SOFC system”), preparatory considerations about the SOFC manufacturing and maintenance and the biogas production are illustrated.

4.1 SOFC system manufacturing and operation

The SOFC manufacturing and operational procedures are calculated and accounted for all the presented scenarios (1, 2.1, 2.2 and 3).

SOFC stack manufacturing

The environmental impact and the process contributions for each impact category for stack manufacturing are shown in Figure 7, and refer to 1 kW of installed capacity).

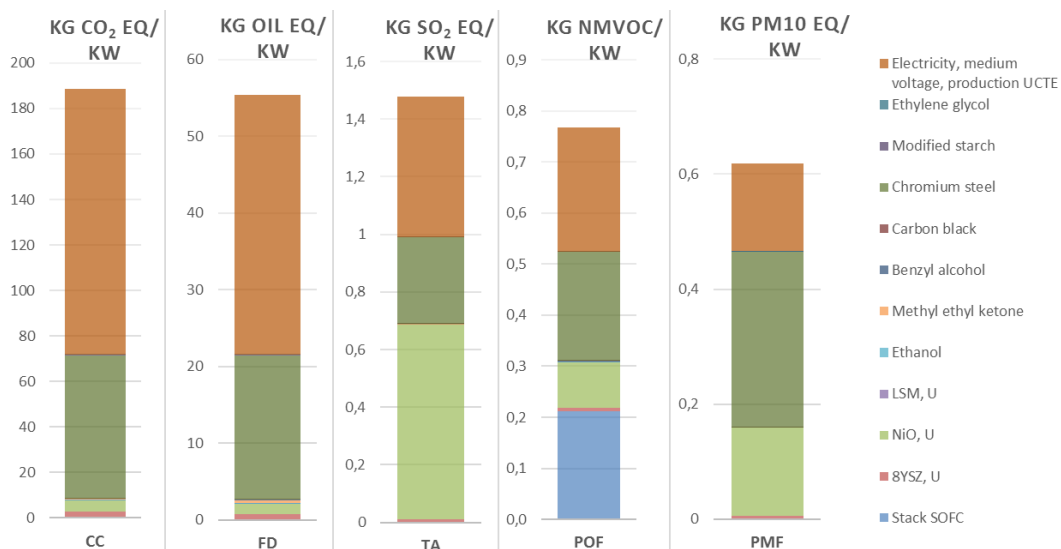

Figure 7. LCIA results for stack manufacturing. Each bar represents one of the impact categories. The scores are reported per kW of installed electric capacity¹.

From the climate change bar (CC), it is possible to read that main contribution come from electricity consumption during the manufacturing phase (62%) and from the employment of stainless steel (33%), both being carbon-intensive products. Moreover, excluding electricity, which is the only energy flow directly involved in stack manufacturing, other materials and

¹ YSZ: Yttrium-stabilized Zirconium (Yttrium 8%mol)

LSM: Lanthanum-Strontium-Manganite

processes result less relevant in respect to steel because they cover only a small part of the total weight of the stack (steel covers about 92% of total weight).

Same considerations apply to fossil depletion category (FD) since in most cases GHG emissions are related to energy consumption (thus combustion of fossil fuels) occurring along the production chain of the materials involved in the analyzed process.

Looking to the column of terrestrial acidification potential (TA), it is possible to see that electricity and steel still cover a wide part of the overall score (33% and 20% respectively). Also, there is the contribution of NiO (46%), which is the raw material employed for the fuel cell anodes.

Regarding photochemical oxidant formation (POF), an important contribution is caused by cell manufacturing (stack SOFC in Figure 7), related to the use of solvents and binders. The other contributions are linked to electricity consumption, steel and nickel oxide employment.

Particulate matter formation (PMF) shows again that electricity, steel and nickel oxide are the main contributors. Stainless steel contribution, about 49% of the total score, is caused by the production of ferrochrome, an alloy of chromium and iron used in the production of stainless steel.

SOFC BoP manufacturing and system assembly

The next set of results, shown in Figure 8, is referred to the assembly of the overall SOFC system, complete with stack and BoP. LCIA results refer to 1 kW of installed capacity.

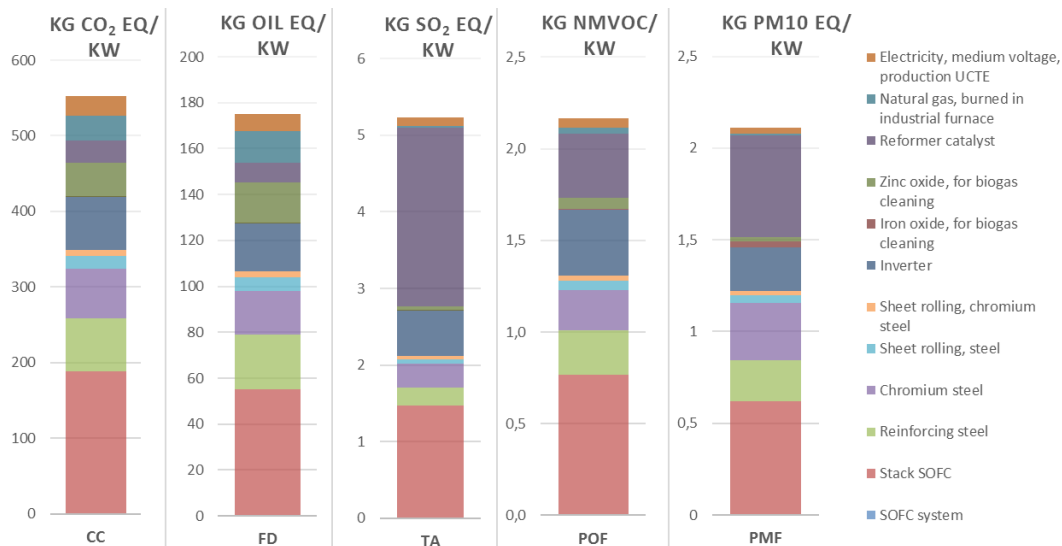

Figure 8. LCIA results for SOFC BoP manufacturing and system assembly. Each bar represents one of the impact categories. The scores are reported per kW of installed electric capacity.

The stack plays a decisive role in determining the potential environmental impacts of the total SOFC system, covering from a minimum of 28% to a maximum of 35%.

For the categories CC and FD, other significant contributions are caused by reinforcing steel (piping, casing), chromium steel (heat exchangers, high temperature components), inverter, Zinc oxide (cleaning), natural gas and electricity consumption (assembly).

Looking at TA, it emerges that the reformer catalyst is responsible for about 44% of the total impact. This high value is related to the extraction process of nickel, responsible for the high emission of sulfur dioxide. On the other hand, the other contributions to acidification potential are related to the combustion of fossil fuels, for different uses (energy production, transportation, etc.).

In POF and PMF impact categories, the same considerations about steel contributions made when speaking about stack manufacturing apply here. Instead, for the inverter and reformer catalyst, a big contribution comes from the extraction phase, of copper and nickel respectively.

SOFC maintenance

The LCIA results for a single manufacturing intervention are reported in Figure 9. LCIA results refer to 1 kW of installed capacity.

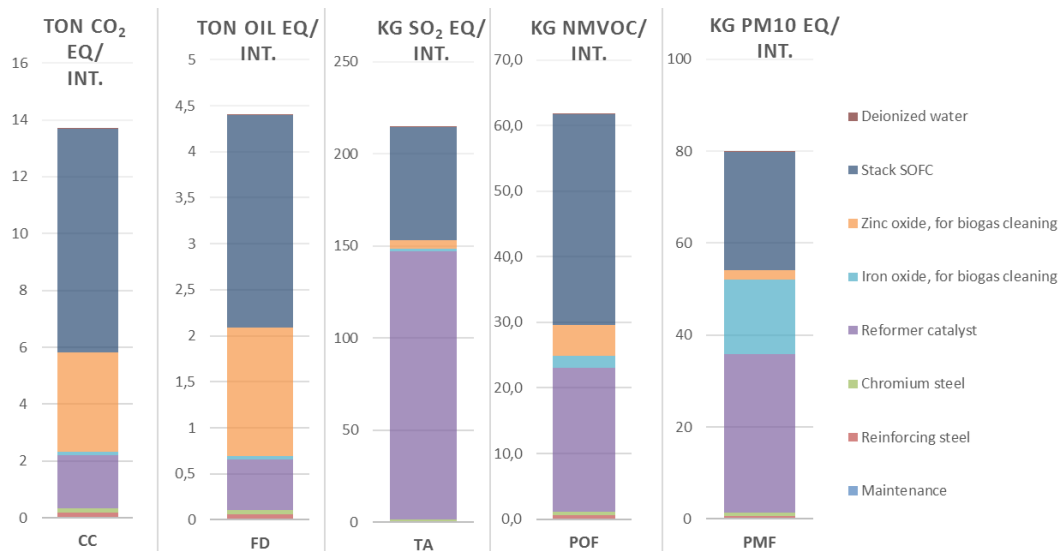

Figure 9. LCIA results for SOFC maintenance. Each bar represents one of the impact categories. The scores are reported per maintenance intervention (INT.).

As explained, stack lifetime is assumed for six years, and it is assumed one maintenance intervention per year. In order to take this into account, the stack replacement is divided over the six interventions, meaning that for each one 17% of the stack is replaced. The consequence is that in CC, FD, and POF impact categories, the overall score is dominated by the stack replacement contribution.

Other significant contributions are related to the reformer catalyst and the materials employed in the cleaning unit. In particular, for CC and FD, zinc oxide represents a significant share of the impact, 25%, and 31% respectively, due to the consumption of fossil fuels occurring during zinc oxide production.

In TA a big contribution comes from the reformer catalyst, about 68% since it is replaced entirely every year.

The catalyst also is responsible for a big share of POF and PMF potentials (36% and 43%). In PMF category, a significant share is also related to the iron oxide (20%) used in the cleaning unit.

4.2 Biogas production

The environmental burdens associated with the production of 1 m³ of biogas are presented for the two scenarios: without sludge pre-thickening (scenario 2.1) and with sludge pre-thickening (scenario 2.2 and 3). Also, separate considerations about GHG emissions are

included, in order to include the emissions of biogenic carbon from the system. Scenario 1, on the other side, is not related to biogas production.

Scenario 2.1: current scenario

In Figure 10a the characterization of the production of 1 m³ of sewage biogas, via AD, without sludge thickening, is shown.

It is immediately clear that the digester energy consumption (both thermal and electric) is key in determining the potential impacts of fuel production. Electricity is required for pumping and recirculation, heat for temperature control.

Regarding CC and FD, the biggest share is covered by the heat provided by the boiler, fueled by natural gas. The thermal power from the SOFC unit shows a much smaller impact compared to that available from NG burning in the boiler. For example, using CC as means of comparison, heat from SOFC is responsible for 9% of the overall GHG emissions, even if it covers 33% of the heat demand of the digester. Heat from natural gas, instead, is responsible for 67% of GHG emissions, and it provides 66% of the digester heat demand (see Appendix A for further information on the inventory).

Looking at the impact categories TA, POF and PMF, consumption of natural gas remains one of the major contributors, but now the use of electricity gains a much higher relative weight. This difference in respect to CC and FD can be explained considering that the quantity of electricity consumed is much less than heat, so the consumption of primary energy is overall less significant, and by direct consequence GHG emissions. On the other hand, electricity production leads to much higher emissions of SO_x, NO_x, and particulates in respect to heat production.

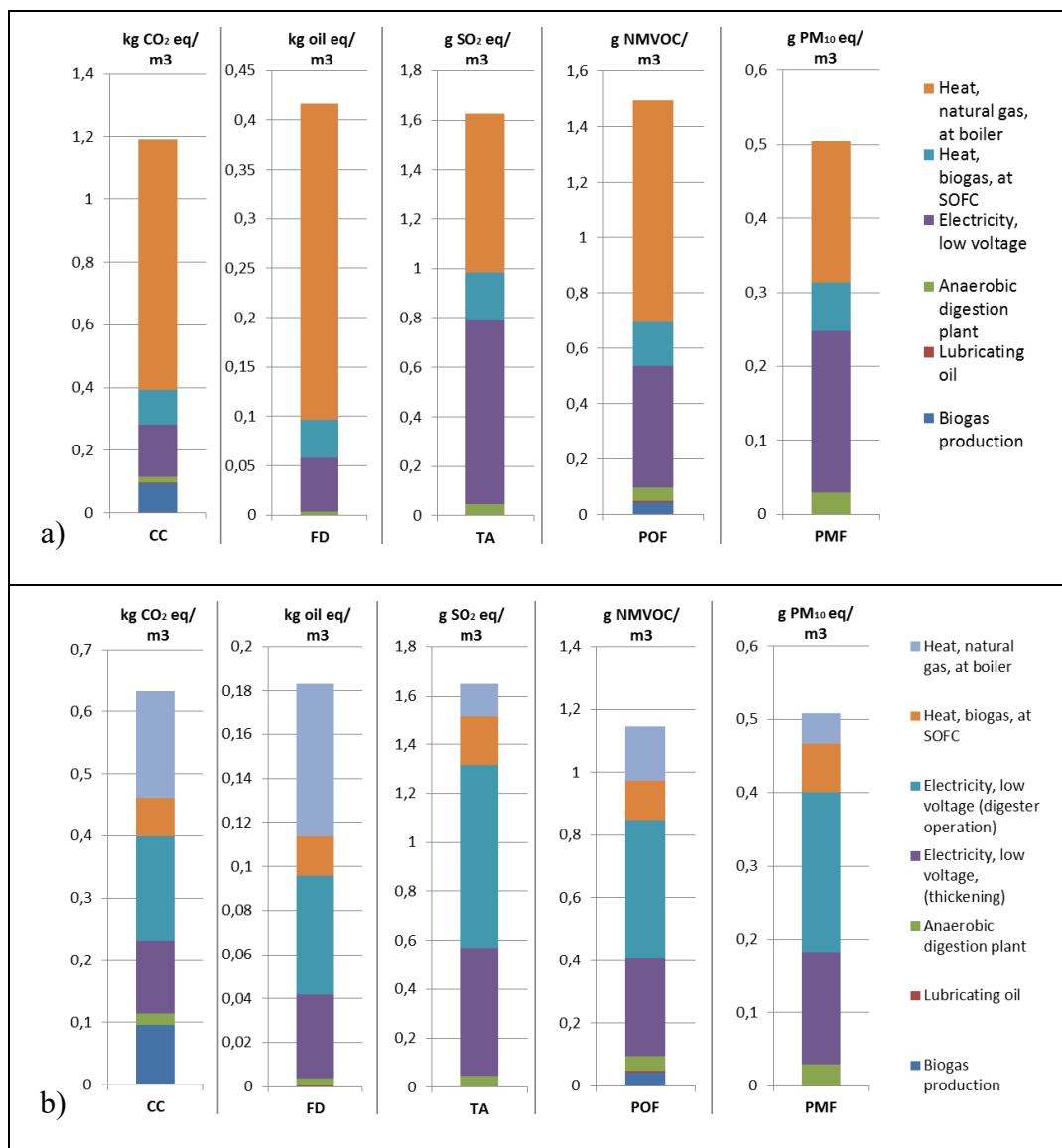

Figure 10. LCIA results for sewage biogas production, without thickening (Figure 10 a) and with thickening (Figure 10 b). Each bar represents one of the impact categories. The scores are reported per m³ of produced biogas.

Scenario 2.2: digester operation with sludge pre-thickening

The second set of results refers to the production of 1 m³ of sewage biogas from the same facility, but including additional machinery for sludge thickening. LCIA characterization for the scenario 2.2 of biogas production is presented in Figure 10b ; the overall scores, compared to the previous scenario, are resumed in Table 1.

Table 1. LCIA results for the production of 1 m³ of sewage biogas for scenarios 2.1 and 2.2.

Impact category	Acronym	Scenario 2.1 W/O thick.	Scenario 2.2 with thick.	Unit
-----------------	---------	----------------------------	-----------------------------	------

Climate change	CC	1.19	0.63	kg CO ₂ eq./ m ³
Fossil depletion	FD	0.42	0.18	kg oil eq. ² / m ³
		17.50	7.70	MJ/ m ³
Terrestrial acidification	TA	1.63	1.65	g SO ₂ eq./ m ³
Photochemical oxidant formation	POF	1.49	1.15	g NMVOC/ m ³
Particulate matter formation	PMF	0.50	0.51	g PM ₁₀ eq./ m ³

Impacts connected to heat generation from natural gas result drastically diminished in the previous case. On the other hand, the new voice of electricity consumption for sludge thickening adds a new, non-negligible share of potential impacts. An overall decrease of CC and FD potential is achieved adding sludge thickening, in particular, 47% decrease in GHG emissions and 56% decrease in fossil fuels consumption.

Another note regarding CC impact category is related to the increased share of impact originated during biogas production. This contribution is linked fundamentally to leaks of methane from the digester. This suggests that after energy efficiency, process efficiency with attention to the leaks through the digester could be the step to further reducing such environmental impacts.

In TA, POF, and PMF impact categories, the overall scores show almost the same values obtained in the scenario without thickening. The difference is that now most of the impacts are related exclusively to electricity consumption and electricity generation is responsible for higher emissions of the substances related to these impact categories, so, in this case, the advantage of introducing sludge thickening is much less evident.

Accounting for GHG emissions

As illustrated in the previous sections, some considerations about the accounting of GHG emissions from biogas production are presented. The choice of not accounting for biogenic CO₂ means to consider the biofuel like a carbon neutral product. The main reasoning behind neutrality of biofuels lay in the assumption that the resulting CO₂ emissions from fuel usage (e.g., for energy generation, transportation, etc.) are counterbalanced by the fixation of atmospheric CO₂ in the growing biomass. However, over the subject of carbon neutrality,

² Explanation: 1 kg of oil equivalent has LHV equal to 42 MJ/kg

there is still no full consensus since it is not completely clear whether or not the temporary storage of CO₂ is beneficial to climate change-related impacts [38].

A separate set of results for climate change is presented, showed in Figure 11, providing a more comprehensive view of the total GHG emissions related to the fuel chain.

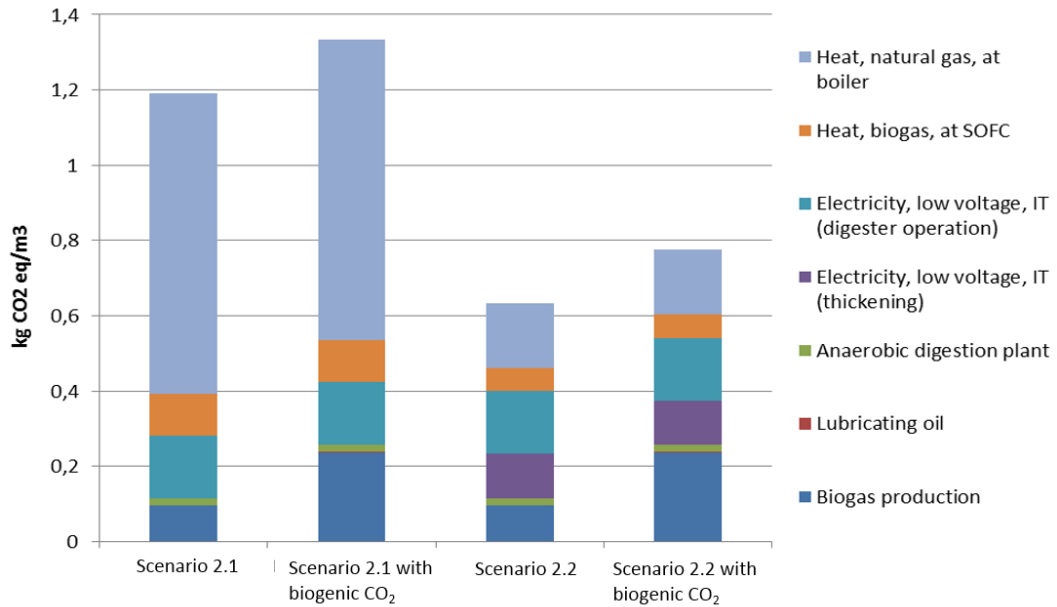

Figure 11. GHG emissions for all biogas production scenarios.

Observing Figure 11, it is again possible to underline the big reduction of GHG emissions when passing from the scenario 2.1 to the scenario 2.2 for digester operation mode. Emissions of biogenic CO₂ occur during the operation of the AD, and they are included in the model under the process “*biogas production.*” For both scenarios, taking into account of these emissions leads to additional 0.14 kg CO₂/m³ of produced biogas. It should also be underlined that, if in the scenario 2.1 this contribution counts less than 11% (due to the high energy-related GHG emissions), in the scenario 2.2 the share of biogenic carbon rises to 18%, hence starting to be a relevant contribution to the overall result.

4.3 Electricity generation

Results obtained for LCIA of 1 kWh of electricity as produced by the SOFC system are presented here. As explained, the SOFC operates in CHP configuration, producing electricity and heat, which is used for digester operation. The consequence of using allocation for multifunctionality, as explained before, is that the environmental burdens related to the fuel

cell operation are divided between electricity and heat, according to the computed allocation factors (Table A4 in Appendix A).

Three scenarios for electricity generation are presented:

- a base case with the SOFC system fueled with natural gas (scenario 1);
- two scenarios for sewage biogas fueled SOFC, reflecting the two different operation modes of the digester (scenario 2.1 and 2.2).

Scenario 1

The first set of results, shown in Figure 12a, provides the environmental profile of electricity generation from SOFC, using natural gas as the fuel of 1 kWh of electricity.

It has to be considered that the energy system is the same for each scenario. Therefore, all the components are assumed as the same. This means for example that the same clean-up unit is used for natural gas and biogas operation. This assumption is made because of lack of data for a coherent modification of the system on the operation mode and because the differences between the two systems are assumed not so relevant to affect the results significantly.

Looking at the results, it emerges that operation of the SOFC dominates the CC category (79%), since most of the GHG emissions are caused by the direct consumption of natural gas for electricity production, while in all the other impact categories operation phase counts almost nothing. The natural gas itself gives another significant contribution to CC (17%), caused mainly during transportation phase (pipeline, freight ship for liquefied gas).

Completely different is the situation for FD impact category, where the natural gas covers almost all the impact (97%). This is, of course, because it is a fossil fuel, so its use counts directly as fossil depletion.

TA impact category sees a bigger contribution from SOFC system and maintenance, but still, most of the impacts are to be attributed to natural gas fuel chain. System and maintenance contributions derive mainly from extraction procedures of nickel, while the emissions related to natural gas are generated during sweetening procedures for natural gas.

POF impact category presents a similar situation to TA, with the addition of a small contribution to fuel cell operation (due to the presence of some pollutants in the flue gas).

The last column, representing PMF, shows a slightly different situation; here, SOFC system and maintenance cover bigger shares of the impact (26% and 23% respectively). Impacts related to infrastructure can be attributed to the extraction of nickel and ferrochrome production (material needed for the production of stainless steel). Maintenance sees as main contributors nickel and iron ore for the substitution of reformer catalyst and cleaning unit materials respectively.

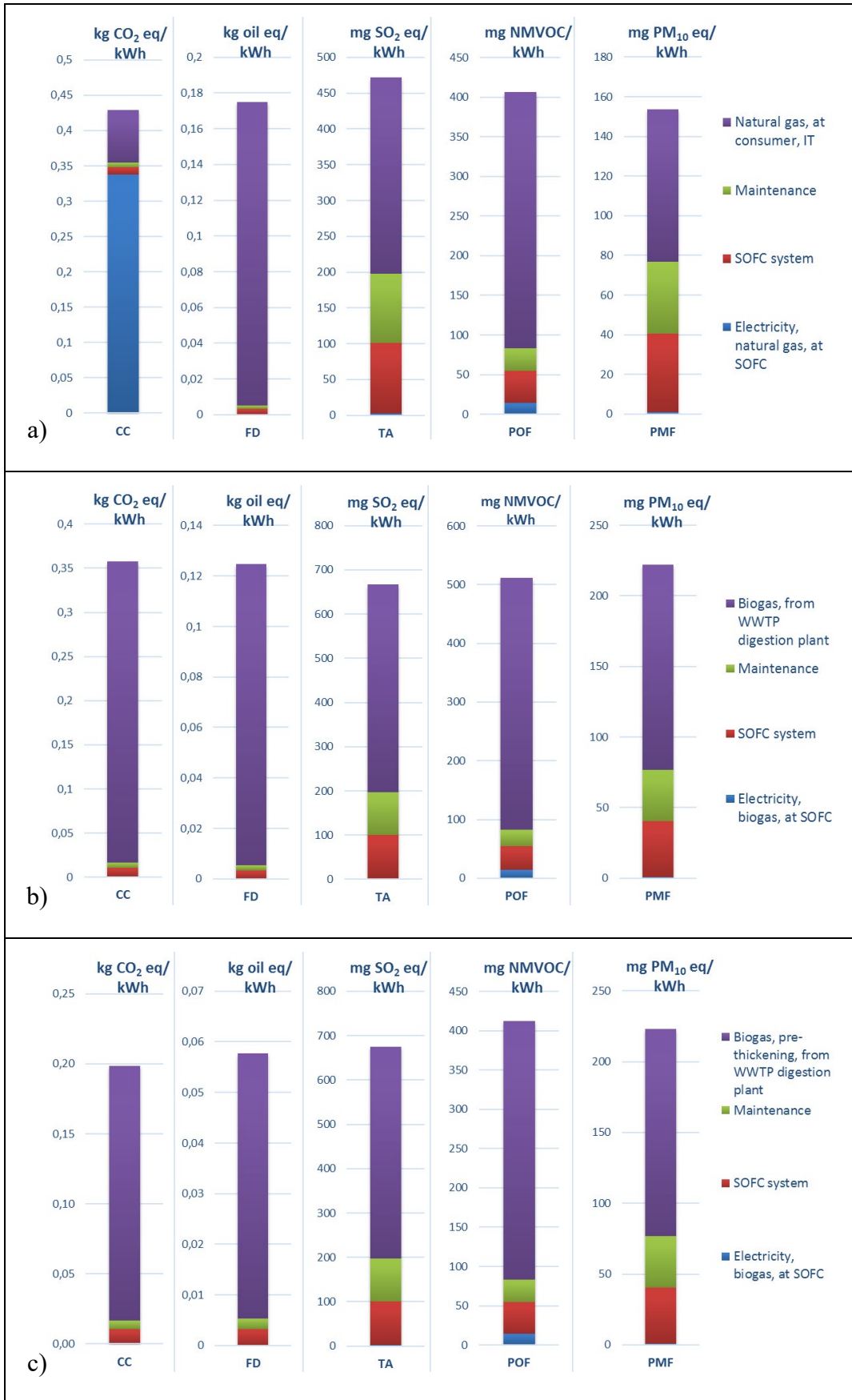

Figure 12. LCIA results for electricity generation, at natural gas, fueled SOFC (Figure 12a) and at biogas fueled SOFC without pre-thickening (Figure 12b) and with pre-thickening (Figure 12c). Each bar represents one of the impact categories. The scores are given per kWh of generated electricity

Scenario 2.1

The second set of results, shown in Figure 12b, provides the environmental profile of electricity generation from SOFC, when it is fueled with biogas, produced without sludge thickening (actual situation), of 1 kWh of electricity.

Looking at Figure 12b is observed that biogas production covers the biggest share in every impact category. In energy systems LCAs, this is a common situation, since the consumption of energy and materials is in general much higher during operation in respect to the manufacturing phase of the power unit.

Looking at CC impact category, biogas production causes quite a high level of GHG emissions. If compared to the fuel chain of natural gas, biogas produces a potential impact 4.6 times higher. This level of GHG emissions related to biogas fuel chain is explained by the high energy requirements of the anaerobic digester, especially for heating.

The CO₂ emitted at SOFC, during operation, is considered as biogenic since it derives from the consumption of a biofuel. Therefore, these emissions are not accounted for computing CC impact indicator.

The same pattern is repeated for FD impact category, where again the fuel chain causes the highest impacts. Similarly to GHG emissions, the main cause of this impact is the consumption of natural gas during digester operation.

TA, POF, and PMF impact categories show a similar distribution of impacts as for the case of natural gas, but the overall scores are the highest. Again, responsible for this high level of emissions is the energy consumption occurring during digester operation.

Scenario 2.2

The third set of results, shown in Figure 12c and Table 2, provides the environmental profile of electricity generation from SOFC when fuel is biogas produced including sludge thickening (scenario 2.2) of 1 kWh of electricity.

Exactly as it happened for the scenario 2.1, biogas production takes the largest share in every impact category. Comparing the profile of Figure 12b and Figure 12c, a strong reduction of

both CC and FD impact categories is reported. If compared with previous results, the overall scores are almost halved. This underlines the positive effect of introducing sludge thickening in the operation mode of the anaerobic digester.

On the other hand, the other three impact categories, TA, POF, and PMF, remain practically unchanged. In fact, only POF sees a slight reduction. The difference of the effect of thickening between impact categories is related to the substitution of the consumption of natural gas for heating with the electricity needed for sludge thickening. As already explained, electricity generation causes more emissions of pollutants from the combustion of natural gas in boilers. Nonetheless, considering the overall situation, this scenario for electricity generation provides a better profile on the previous one.

Table 2. LCIA results for the generation of 1 kWh of electricity, at SOFC, fueled with biogas. Comparison between scenarios 2.1 and 2.2.

Impact category	Acronym	Scenario 2.1 W/O thick.	Scenario 2.2 with thick.	Unit
Climate change	CC	0.36	0.20	kg CO ₂ eq./ kWh
Fossil depletion	FD	0.12	0.06	kg oil eq./ kWh
		5.24	2.43	MJ/ kWh
Terrestrial acidification	TA	668	674	mg SO ₂ eq./ kWh
Photochemical oxidant formation	POF	512	412	mg NMVOC/ kWh
Particulate matter formation	PMF	22	223	mg PM ₁₀ eq./ kWh

Accounting for GHG emissions

In Figure 13 it is possible to see a comprehensive accounting for GHG emissions for all the scenarios considered for electricity generation. Where the production is obtained through the use of biogas, two results are presented: with and without counting the emissions of biogenic CO₂.

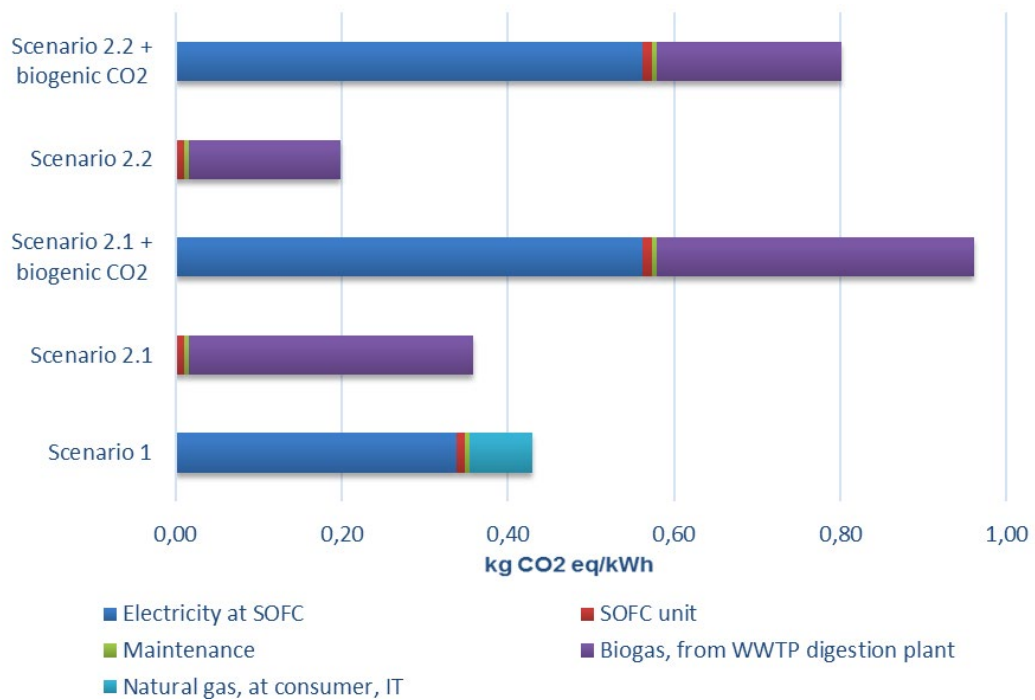

Figure 13. GHG emissions for all electricity generation scenarios.

Looking to the figure, it is immediately evident that biogenic carbon changes the scores of GHG emissions of biogas electricity scenarios completely. Emissions of biogenic CO₂ from fuel cell operation (electricity, at SOFC) are even higher on natural gas use since biogas is partly composed of CO₂ (40%).

The effect of counting biogenic CO₂ leads to an increase in GHG emissions of 170% for the first scenario of electricity generation from biogas, while the growth in the second scenario is 300%. It also has to be underlined that even if no production of biogas (for energy purposes) were included at WWTP, emissions of biogenic CO₂ from wastewater treatment would occur.

Comparison of different scenarios (scenario 1, 2.1, 2.2)

In Figure 14 a comparison between the different scenarios is shown.

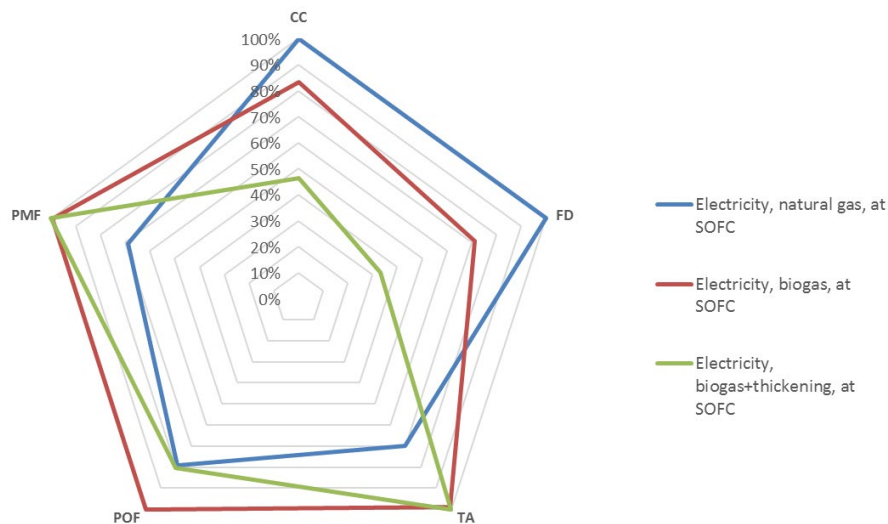

Figure 14. Comparison of LCIA results between the scenarios for electricity generation.

The comparison puts in evidence that the use of biogas is beneficial compared to natural gas when considering CC and FD impact categories. The benefit is greater when biogas production includes sludge pre-thickening.

On the other hand, in TA, POF, and PMF impact categories, the trend is different, and natural gas shows the best environmental performance. This situation is because of biogas production, hence anaerobic digester operation, is an energy-intensive process. This energy consumption causes the emissions of substances like NO_x , SO_x , and particulates, pollutants responsible for the impact categories cited before.

4.4 Scenario 3

In this section, the environmental performance of the PBR is studied. PBR is not treated in the same way as the SOFC and the biogas fuel chain. In fact, the following remarks about the PBR, used as a CO_2 recovery system, do not represent a complete LCA of the technology. Given the high level of model uncertainty, due to lack of information and knowledge, it was studied separately from the other parts of the overall system.

PBRs positive effects are both CO_2 sequestration and production of biomass, which could be employed, among a series of possible choices, for biofuels generation.

Mentioned paper CCR [5]

Following this idea of using algae for energy purposes, the first and fundamental requirement would be that the production of biomass would result in a net positive energy balance. This

information is also contained in LCI where the energy efficiency of algae production is calculated and equal to 10.5%. The energetic performance of the PBR is even less favorable if, instead of the electricity consumption, primary energy consumption is used to evaluate the process. Using FD as the indicator for the level of primary energy consumption, the production of 1 kg of algae is responsible for the consumption of 11.6 kg of oil equivalent (487 MJ), 23 times the energy produced.

To give an example, following one of the possible energy paths for algae, it is presented the case of anaerobic digestion for biogas generation, used for electricity generation using SOFCs. Geographical convenience drives this choice; since the site where the PBR is installed (WWTP) already has the infrastructure for biomass digestion (anaerobic digester) and the technology for electricity generation (SOFC). Being the goal of this example only to give the order of magnitude of the energy flows involved, the following hypotheses have been made:

- No additional energy consumptions are included for algae processing into biogas; they are considered negligible in respect to PBR consumptions;
- A coefficient of biogas yield of 0.13 m³/kg, according to [39], is chosen;
- Electrical efficiency of SOFC is taken as 52%, according to [2];

Using these data, it is computed that for the production of 1 kWh of electricity at SOFC 140 kWh of electricity would be consumed for PBR operation, almost three times the energy consumed for the production of 1 kg of biomass.

At PBR level, it is calculated that 60% of the total emissions of CO₂ from SOFC are fixated in biomass. The rest is released into the atmosphere. For the production of 1 kg of biomass, this translates into a consumption of 1.84 kg of biogenic CO₂ and emissions for 1.23 kg biogenic CO₂. To these emissions, using CC impact category, evaluated for PBR operation, it must be added another 35.9 kg of CO₂ eq. Overall GHG emissions are 20 times more the CO₂ consumption.

Conclusively, the chosen PBR technology, according to the available information and of the choices made for its operating mode, does not provide either energy or CO₂ sequestration-effective contribution to the original energy path (biogas-fed SOFC).

However, these conclusions do not imply a negative judgment of the concept of achieving positive effects in contexts similar to the one presented. More research is required to identify

and understand all the parameters involved in the functioning of such complex system, and new designs would propose more interesting performances (e.g. hybrid PBR) [40].

4.5 Uncertainty analysis

The Monte Carlo simulations are performed fixing the number of runs to 1000, with a confidence interval of 95%. Each simulation produces a set of LCIA results for the analyzed component of the system. The final output is a distribution of the results, for all the impact categories taken into consideration.

In the present study, the Pedigree Matrix has been used. It is a semi-quantitative tool used to estimate inventory data uncertainty; this makes possible to produce distribution for the results, thus revealing the effect of data uncertainty on LCIA results. This choice is done in accordance to [41] and also in compliance with many other inventories included in Ecoinvent[®] database. Thus, uncertainty information, in the form of standard deviation, is evaluated for each of the inventory items, according to the uncertainty indicators. In Table 3, results of Monte Carlo simulations for the selected LCIA impact categories are shown.

Table 3. Uncertainty characterization of LCIA results for different electricity generation scenarios. Results are obtained through Monte Carlo simulation, using a fixed number of 1000 iterations.

Impact Factor and Confidence Interval	CC		FD		TA		POF		PMF	
	2.5%	97.5%	2.5%	97.5%	2.5%	97.5%	2.5%	97.5%	2.5%	97.5%
Electricity generation using NG	0.4	0.46	0.13	0.23	356	640	319	510	112	217
Electricity generation using biogas w/o thick	0.3	0.43	0.1	0.15	552	856	426	626	179	295
Electricity generation using biogas with thick	0.17	0.23	0.05	0.07	558	867	351	500	180	299

The analysis has been performed for SOFC system manufacturing, biogas production, and electricity generation. Only results for the last case study are shown. No overlapping of distributions with significantly different mean can be outlined when considering the comparison between electricity generation scenarios. This implies that the comparisons made still stand after the simulations, none of them have to be revised here.

5. Discussion

Results show that stack manufacturing is strongly affected by steel employment (interconnect, casing) and by electricity consumption (tape casting, co-firing, screen printing, sintering).

Observing the results for BoP manufacturing and system assembly, SOFC covers a significant share of impacts in all the categories, proving to be the most relevant component of the system (even if it does not cover more than 35% of the impact in any category). Other significant contributions come from BoP and assembly: steel and stainless steel (casing, piping, heat exchangers), inverter and reformer catalyst. It is worthwhile noting the role of the reformer catalyst in TA and PMF, where it covers respectively 44% and 26% of the total potential impact. GHG emissions are taken as a term of comparison between the case study and other literature findings. The comparison for SOFC manufacturing is reported in Table 4.

Table 4. Comparison of SOFC life cycle GHG emissions between the case study and similar studies [13,41–44].

Reference	Climate change	Notes
	kg CO ₂ eq./kW	
Case study	552	
Staffell et al. (2012) [42]	414-534	<i>Merged inventory for 1 kW stack; BOP not included.</i>
Karakoussis et al. (2001) [43]	383	<i>Based on 1 kW Sulzer HEXIS planar SOFC.</i>
Strazza et al. (2010) [13]	530	<i>LCA of a 20 kW SOFC as auxiliary system.</i>
Baratto et al. (2005) [44]	326	<i>Life Cycle Assessment of a 5 kW planar SOFC as auxiliary power unit.</i>
Primas et al. (2007) [41]	620	<i>Simapro[®] report on CHP; LCA of a 125 kW tubular SOFC.</i>

The potential impacts of SOFC maintenance are also shown, and main contributors to the environmental impacts are stack replacement, Zinc and Iron Oxides for biogas clean-up and reformer catalyst.

LCIA results for biogas production include the two scenarios for digester operation, plus a separate accounting for GHG emissions, included for underlying the role of biogenic emissions in the process.

Looking at the results of the first scenario for anaerobic digester operation (scenario 2.1), energy consumption, and in particular, natural gas for heating is the leading cause of

environmental burdens. A similar situation is found in the scenario 2.2, for which the difference among CC and FD scores is almost halved, due to natural gas savings. On the other hand, TA, POF, and PMF impact categories show almost the same results. This situation is due to the increase in electricity consumption, which causes higher environmental impacts for the cited categories. When performing a comprehensive accounting of GHG emissions, biogenic CO₂ creates an increase of 11% (first scenario) and 18% (second scenario) in CC potential impact, meaning that to biogenic carbon could be attributed a non-negligible share of this impact.

Electricity generation results are presented both for NG and biogas feedings. For all the assessed impact categories, except CC, the fuel chain of natural gas plays a decisive role, covering the largest share of the potential impacts. Concerning CC, the main share is covered by direct emissions from SOFC during operation.

On the other hand, TA and PMF categories depict a relevant contribution from both SOFC system and maintenance. These impacts are related to the materials for reformer and cleaning unit. Similarly to Table 4, in Table 5 is presented a comparison between the case study and other literature results, for electricity generation in natural gas-fed SOFC.

Table 5. Comparison of natural gas-fed SOFC GHG emissions between the case study and similar studies [13,41–44].

Reference	Climate change	Notes
	kg CO ₂ eq./kW	
Case study	430	
Staffell et al. (2012) [42]	391	<i>Merged inventory for 1 kW SOFC stack; BoP not included.</i>
Karakoussis et al. (2001) [43]	228	<i>Based on 1 kW Sulzer HEXIS planar SOFC.</i>
Strazza et al. (2010) [13]	480	<i>LCA of a 20 kW SOFC as auxiliary system.</i>
Baratto et al. (2005) [44]	597	<i>Life Cycle Assessment of a 5 kW planar SOFC as auxiliary power unit.</i>
Primas et al. (2007) [41]	448	<i>Simapro[®] report on CHP; LCA of a 125 kW tubular SOFC.</i>

Compared to scenario 1, both scenarios of biogas operation (scenario 2.1 and 2.2) show better performance in CC and FD impact categories, while in TA, POF, and PMF the levels of potential impacts are slightly higher, due to the consequences of biogas production (Figure 10).

To provide a perspective view of SOFC performance on alternative technologies, a comparison between the SOFC modeled in the present study, a micro gas turbine and an internal combustion engine are given in Figure 15.

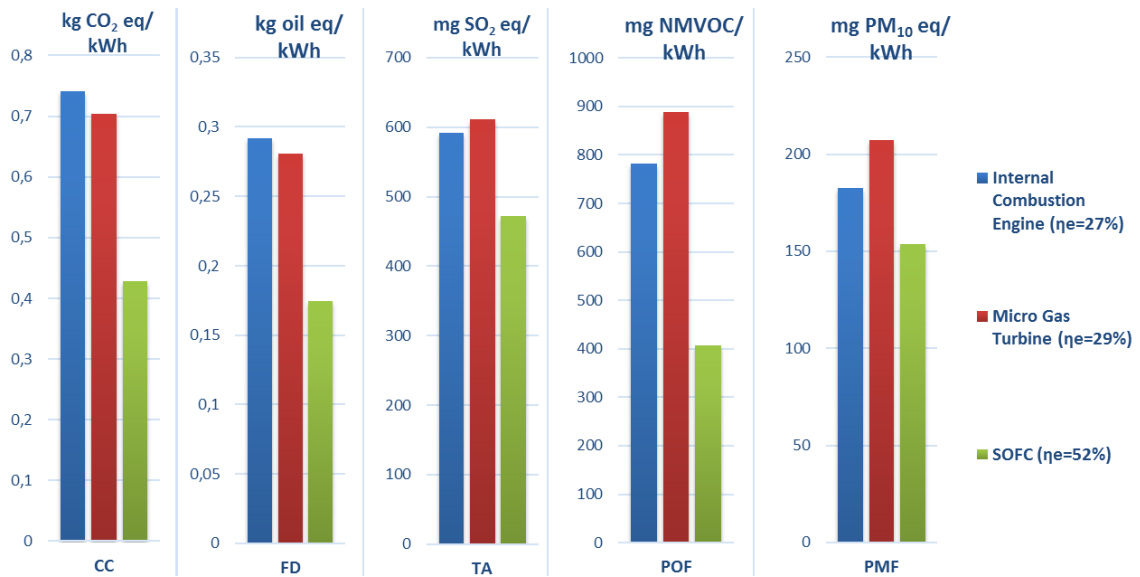

Figure 15. Comparison between natural gas-fed CHP technologies. Internal Combustion Engine refers to a 160 kWe unit (ηe 27%), Micro gas turbine refers to a 100 kWe unit (ηe 29%), SOFC to the unit under study, 250 kWe and ηe 52%.

Figure 15 clearly shows a better eco-profile for the SOFC on the other two competing power technologies. The main reason for this difference lies in the better electrical conversion efficiency of the fuel cell. In fact, if at small sizes conventional technologies have low efficiencies, SOFC is less affected by size; therefore, proving to be a valid competitor for electricity generation in the chosen range of capacities.

As for biogas production, accounting for biogenic carbon emissions is also performed for electricity generation. The results show that when including biogenic CO₂, the overall emissions of GHG gasses at electricity generation increase significantly. Hence, it is not surprising that the GHG emission increases from 0.36 to 0.96 kg CO₂ eq./kWh for the first scenario of biogas production and from 0.20 to 0.80 kg CO₂ eq./kWh for the second scenario.

Lastly, following the assumptions and calculations for PBR operation mode (Scenario 3), it emerged that this component does not provide benefits to the system, neither from an energetic nor a carbon capture point of view. In fact, even if it is not possible to characterize the system thoroughly, to perform a complete LCA, electricity consumption for pumping is so high that alone it compromises the effectiveness of the scheme. To give a quantitative

representation, FD and CC potential impacts are calculated, showing that the PBR operation would consume 23 times the energy produced and that GHG emissions would be 20 times higher than the CO₂ sequestered and fixed in biomass. Better process design and component level- technology improvement on the PBR are expected to help much reducing these impact making the PBR more competitive.

6. Conclusions

In the present study, LCA for SOFC technology (planar, anode supported cells) is performed. Included life cycle phases are manufacturing and operation of the system. Different operation modes are considered, depending on the chosen fuel (natural gas, biogas). End-of-life scenarios were not included in this work. Also, a separate assessment of the performance of a tubular PBR, employed as a CO₂ recovery system, is presented.

One of the goals of the study is to prove the suitability of SOFC technology as a valid alternative to conventional systems, such as ICEs and micro gas turbines, especially for small capacities (<1MW_e). After the analysis performed, it is possible to conclude that in fact, SOFC offers better performance. Assuming that the fuel chain is the same in all the cases and that the power units themselves give little contributions, such success can be attributed to two main features of SOFC:

- High electrical efficiency;
- Very low emissions of pollutants during operation (SO_x, NO_x, VOCs, particulate).

Moreover, SOFC technology proves to be a competitive technology also on a wider panorama for electricity generation. This conclusion is taken after the comparison of lifecycle GHGs, SO_x, NO_x, PM_{2.5} and NMVOCs emissions between the SOFC system analyzed in the present study (both natural gas and biogas operation) with other technologies and energy sources.

Considering the overall work, it is found that the most significant added value relies on the implementation of the model itself, more than in the numerical results. In fact, the characterization of the processes included in the system boundaries provides a holistic comprehension of the energy path, from the fuel chain to the manufacture and operation of the power unit, to the CO₂ recovery system. This comprehensive view exposes critical

points, underlines optimization opportunities, and permits easy modifications, allowing obtaining other results with much smaller effort.

In conclusion to this work, a few suggestions for further studies are listed:

- More detailed data collection, with focus on obtaining information from manufacturers and facilities, increasing the representativeness, hence the value of the final results;
- Collection of uncertainty information of inventory data, through personal sampling and/or communications from manufacturers, guaranteeing higher quality of data;
- Investigation of GHG alternative scenarios, for example, credits from avoided emissions from waste management, effect on system performance of accounting for biogenic carbon emissions;
- Investigation of different paths to evaluate the absolute uncertainty of LCA results;
- Separate LCAs of photobioreactors needed to understand their full potential as well as to point out major weaknesses;
- Feasibility analyses of bioreactors employment as carbon recovery systems.

7. Acknowledgments

The research leading to these results has received funding from the European Union's Seventh Framework Program (FP7/2007-2013) for the Fuel Cells and Hydrogen Joint Technology Initiative under grant agreement number 278798 'SOFCOM.'

References

- [1] Lanzini A, Ferrero D, Santarelli M. *Energy System Analysis of SOFC Systems*, Springer International Publishing; 2017, p. 223–64. doi:10.1007/978-3-319-46146-5_6.
- [2] Gandiglio M, Lanzini A, Santarelli M, Leone P. Design and balance of plant of a demonstration plant with a Solid Oxide Fuel Cell fed by biogas from Waste-water and exhaust carbon recycling for algae growth. *J Fuel Cell Sci Technol* 2013;11:14. doi:10.1115/FuelCell2013-18082.
- [3] Tjaden B, Gandiglio M, Lanzini a., Santarelli M, Järvinen M. Small-scale biogas-SOFC plant: Technical analysis and assessment of different fuel reforming options. *Energy and Fuels* 2014;28:4216–32. doi:10.1021/ef500212j.
- [4] Papurello D, Lanzini A, Tognana L, Silvestri S, Santarelli M. Waste to energy: Exploitation of biogas from organic waste in a 500 kW solid oxide fuel cell (SOFC) stack. *Energy* 2015;85:145–58. doi:10.1016/j.energy.2015.03.093.
- [5] Santarelli M, Briesemeister L, Gandiglio M, Herrmann S, Kuczynski P, Kupecki J, et al. Carbon recovery and re-utilization (CRR) from the exhaust of a solid oxide fuel cell (SOFC): analysis through a proof-of-concept. *J CO2 Util* 2017;18:206–21. doi:http://dx.doi.org/10.1016/j.jcou.2017.01.014.
- [6] Curletti F, Gandiglio M, Lanzini A, Santarelli M, Maréchal F. Large size biogas-fed Solid Oxide Fuel Cell power plants with carbon dioxide management: Technical and economic optimization. *J Power Sources* 2015;294:669–90. doi:10.1016/j.jpowsour.2015.06.091.
- [7] Lunghi P, Bove R, Desideri U. LCA of a molten carbonate fuel cell system 2004;137:239–47. doi:10.1016/j.jpowsour.2004.06.005.
- [8] Raugei M, Bargigli S, Ulgiati S. A multi-criteria life cycle assessment of molten carbonate fuel cells (MCFC)— a comparison to natural gas turbines 2005;30:123–30. doi:10.1016/j.ijhydene.2004.04.009.
- [9] Mehmeti A, Santoni F, Della M, Mcphail SJ. Life cycle assessment of molten carbonate fuel cells : State of the art and strategies for the future. *J Power Sources* 2016;308:97–108. doi:10.1016/j.jpowsour.2015.12.023.
- [10] Ally J, Pryor T. Life cycle costing of diesel , natural gas , hybrid and hydrogen fuel cell bus systems : An Australian case study. *Energy Policy* 2016;94:285–94. doi:10.1016/j.enpol.2016.03.039.
- [11] Ahmadi P, Kjeang E. ScienceDirect Comparative life cycle assessment of hydrogen fuel cell passenger vehicles in different Canadian provinces. *Int J Hydrogen Energy* 2015;40:12905–17. doi:10.1016/j.ijhydene.2015.07.147.
- [12] Wang D, Zamel N, Jiao K, Zhou Y, Yu S, Du Q, et al. Life cycle analysis of internal combustion engine , electric and fuel cell vehicles for China. *Energy* 2017;59:402–12. doi:10.1016/j.energy.2013.07.035.
- [13] Strazza C, Del Borghi a., Costamagna P, Traverso a., Santin M. Comparative LCA of methanol-fuelled SOFCs as auxiliary power systems on-board ships. *Appl Energy* 2010;87:1670–8. doi:10.1016/j.apenergy.2009.10.012.

- [14] Nease J, Li TAA. Comparative life cycle analyses of bulk-scale coal-fueled solid oxide fuel cell power plants. *Appl Energy* 2015;150:161–75. doi:10.1016/j.apenergy.2015.03.105.
- [15] Lin J, Babbitt CW, Trabold TA. Bioresource Technology Life cycle assessment integrated with thermodynamic analysis of bio-fuel options for solid oxide fuel cells. *Bioresour Technol* 2013;128:495–504. doi:10.1016/j.biortech.2012.10.074.
- [16] Mehmeti A, Mcphail SJ, Pumiglia D, Carlini M. Life cycle sustainability of solid oxide fuel cells: From methodological aspects to system implications. *J Power Sources* 2016;325:772–85. doi:10.1016/j.jpowsour.2016.06.078.
- [17] Strazza C, Del A, Costamagna P, Gallo M, Brignole E, Girdinio P. Life Cycle Assessment and Life Cycle Costing of a SOFC system for distributed power generation. *Energy Convers Manag* 2015;100:64–77. doi:10.1016/j.enconman.2015.04.068.
- [18] Tonini D, Astrup T. LCA of biomass-based energy systems: A case study for Denmark. *Appl Energy* 2012;99:234–46. doi:10.1016/j.apenergy.2012.03.006.
- [19] Evangelisti S, Lettieri P, Borello D, Clift R. Life cycle assessment of energy from waste via anaerobic digestion: A UK case study. *Waste Manag* 2014;34:226–37. doi:10.1016/j.wasman.2013.09.013.
- [20] Mezzullo WG, Mcmanus MC, Hammond GP. Life cycle assessment of a small-scale anaerobic digestion plant from cattle waste. *Appl Energy* 2013;102:657–64. doi:10.1016/j.apenergy.2012.08.008.
- [21] Hijazi O, Munro S, Zerhusen B, Effenberger M. Review of life cycle assessment for biogas production in Europe. *Renew Sustain Energy Rev* 2016;54:1291–300. doi:10.1016/j.rser.2015.10.013.
- [22] Evangelisti S, Lettieri P, Clift R, Borello D, Università S. Distributed generation by energy from waste technology: A life cycle perspective. *Process Saf Environ Prot* 2014;93:161–72. doi:10.1016/j.psep.2014.03.008.
- [23] Carnevale E, Lombardi L. Comparison of different possibilities for biogas use by Life Cycle Assessment 2015;81:215–26. doi:10.1016/j.egypro.2015.12.088.
- [24] Barrera EL, Rosa E, Spanjers H, Romero O, Meester S De, Dewulf J. A comparative assessment of anaerobic digestion power plants as alternative to lagoons for vinasse treatment: life cycle assessment and exergy analysis. *J Clean Prod* 2016;113:459–71. doi:10.1016/j.jclepro.2015.11.095.
- [25] Arespachaga N De, Valderrama C, Peregrina C, Hornero A, Bouchy L, Cortina JL. On-site cogeneration with sewage biogas via high-temperature fuel cells: Benchmarking against other options based on industrial-scale data. *Fuel Process Technol* 2015;138:654–62. doi:10.1016/j.fuproc.2015.07.006.
- [26] Monari C, Righi S, Irving S. Greenhouse gas emissions and energy balance of biodiesel production from microalgae cultivated in photobioreactors in Denmark: a life-cycle modeling. *J Clean Prod* 2016;112:4084–92. doi:10.1016/j.jclepro.2015.08.112.
- [27] Pragya N, Pandey KK. Life cycle assessment of green diesel production from microalgae. *Renew Energy* 2016;86:623–32. doi:10.1016/j.renene.2015.08.064.

- [28] Resurreccion EP, Colosi LM, White MA, Clarens AF. Bioresource Technology Comparison of algae cultivation methods for bioenergy production using a combined life cycle assessment and life cycle costing approach. *Bioresour Technol* 2012;126:298–306. doi:10.1016/j.biortech.2012.09.038.
- [29] DEMOSOFC project official website n.d. www.demosofc.eu (accessed December 20, 2015).
- [30] Mehr AS, Gandiglio M, MosayebNezhad M, Lanzini A, Mahmoudi SM, Yari M, et al. Solar-assisted integrated biogas solid oxide fuel cell (SOFC) installation in wastewater treatment plant: energy and economic analysis. *Appl Energy* 2017;191:620–38.
- [31] Gandiglio M, Mehr AS, Lanzini A, Santarelli M. DESIGN, ENERGY MODELING AND PERFORMANCE OF AN INTEGRATED INDUSTRIAL SIZE BIOGAS SOFC SYSTEM IN A WASTEWATER TREATMENT PLANT. *Proc ASME 2016 14th Int Conf Fuel Cell Sci Eng Technol FUELCELL2016 June 26-30, 2016, Charlotte, North Carolina 2016*.
- [32] Gandiglio M, Lanzini A, Santarelli M, Leone P. Design and Balance-of-Plant of a Demonstration Plant With a Solid Oxide Fuel Cell Fed by Biogas From Waste-Water and Exhaust Carbon Recycling for Algae Growth. *J Fuel Cell Sci Technol* 2014;11:31003. doi:10.1115/1.4026088.
- [33] Lorenzi E, Scibilia G, Gandiglio M. SOFCOM Mid-Term Review: Work Package 4 n.d.
- [34] ISO. ISO 14040:2006 - Environmental management -- Life cycle assessment -- Principles and framework 2006.
- [35] ISO. ISO 14044:2006 - Environmental management -- Life cycle assessment -- Requirements and guidelines 2006.
- [36] European Commission -- Joint Research Centre -- Institute for Environment and Sustainability. International Reference Life Cycle Data System (ILCD) Handbook -- General guide for Life Cycle Assessment -- Detailed guidance. 2010. doi:10.2788/38479.
- [37] Goedkoop M, Heijungs R, De Schryver A, Struijs J, van Zelm R. ReCiPe 2008. A LCIA method which comprises harmonised category indicators at the midpoint and the endpoint level. *Characterisation. A Life Cycle Impact ...* 2013:133. doi:http://www.lcia-recipe.net.
- [38] Brandão M, Levasseur A, Kirschbaum MUF, Weidema BP, Cowie AL, Jørgensen SV, et al. Key issues and options in accounting for carbon sequestration and temporary storage in life cycle assessment and carbon footprinting. *Int J Life Cycle Assess* 2012;18:230–40. doi:10.1007/s11367-012-0451-6.
- [39] Rotella D. Energy recovery from microalgae. 2014.
- [40] Singh RN, Sharma S. Development of suitable photobioreactor for algae production – A review. *Renew Sustain Energy Rev* 2012;16:2347–53.
- [41] Primas A. Life Cycle Inventories of new CHP systems. *ecoinvent report No. 20. vol. 0. 2007*.
- [42] Staffell I, Ingram A, Kendall K. Energy and carbon payback times for solid oxide fuel

- cell based domestic CHP. *Int J Hydrogen Energy* 2012;37:2509–23. doi:10.1016/j.ijhydene.2011.10.060.
- [43] Karakoussis V, Brandon N., Leach M, van der Vorst R. The environmental impact of manufacturing planar and tubular solid oxide fuel cells. *J Power Sources* 2001;101:10–26.
- [44] Baratto F, Diwekar UM. Life cycle assessment of fuel cell-based APUs. *J Power Sources* 2005;139:188–96. doi:10.1016/j.jpowsour.2004.07.025.