

Assessment of Cognitive Student Engagement Using Heart Rate Data in Distance Learning during COVID-19

*Original*

Assessment of Cognitive Student Engagement Using Heart Rate Data in Distance Learning during COVID-19 / Ladino Nocua, A.C., Cruz Gonzalez, J.P., Castiblanco Jimenez, I.A., Gomez Acevedo, J.S., Marcolin, F., Vezzetti, E.. - In: EDUCATION SCIENCES. - ISSN 2227-7102. - ELETTRONICO. - 11:9(2021), p. 540. [10.3390/educsci11090540]

*Availability:*

This version is available at: 11583/2923934 since: 2021-09-15T10:48:48Z

*Publisher:*

MDPI

*Published*

DOI:10.3390/educsci11090540

*Terms of use:*

This article is made available under terms and conditions as specified in the corresponding bibliographic description in the repository

*Publisher copyright*

(Article begins on next page)

# Techno-Talk: An American Sign Language (ASL) Translator

Arslan Arif, Syed Tahir Hussain Rizvi  
Politecnico Di Torino  
Turin, Italy  
arslan.arif@polito.it

Iqra Jawaid, Muhammad Adam Waleed,  
Muhammad Raheel Shakeel  
Faculty of Engineering  
University of Central Punjab  
Lahore, Pakistan

**Abstract**—In this paper, an accurate implementation of American Sign Language Translator is presented. It is a portable electronic hand glove to be used by any deaf/mute person to communicate effectively with the others who don't understand sign language. It provides the visual and audible output on an LCD and through a speaker respectively. This glove consists of five flex sensors that senses the variation in different signs, an accelerometer to distinguish between the static and dynamic signs, a contact sensor, Arduino Mega 2560 for processing of the data, VoiceBox shield, LCD and Speaker for the outputs. There exists a communication gap between the normal and the disabled people. A simpler, easier, useful and efficient solution to fill this void is presented in this paper

**Keywords**— American Sign Language, Hand Glove, Sensor based, Microcontroller, Sign Translator, Visual and Audible Outputs

## I. Introduction

Sign Language is definitely a boon to deaf and mute people for communicating in daily life. Obviously there exists a great communication gap in communication of a deaf person with the normal. In sign language, a person conveys message by the help of movement of hands rather than sound patterns. It may involve simultaneously defined shapes, orientation and movement of the body parts.

A sign language to be processed for translation can be captured using visual sensor like camera or force sensor like flex. In this work, flex sensor placed on gloves is used to capture the sign language as shown in the block diagram in Fig 1. These flex sensors are placed on the glove. 5 flex sensors are attached for every finger. Contact sensor and accelerometer are also required for distinguishing some signs. Combination of inputs from Flex sensors, accelerometer and contact sensor are processed in microcontroller Arduino Mega 2560 for recognizing the sign. After recognition of sign, detected signs are transferred to voice box shield serially which converts the serial message to voice message and same message is also displayed on Liquid crystal Display.

“Techno-Talk” aims to translate American Sign Language gestures to anyone anywhere in the world who uses the system to transmit his / her message. The purpose of this device is to help the user to interact with people through an effective way minimizing their handicap and enable them to broaden their senses.

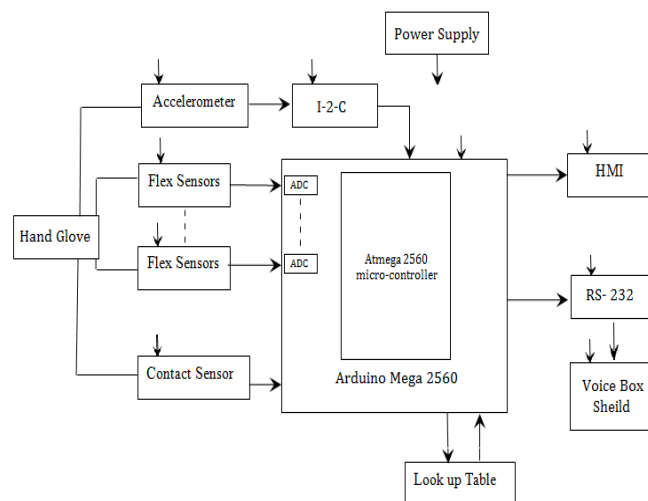

Fig 1 Block Diagram of System

This paper discusses all the aspects of implementation of “Techno-Talk” in detail. Section II presents a brief overview of the related work on sign language translation. Section III proposes the methodology. In Section IV, used hardware components are discussed and the results are presented in section V. The conclusions and recommendations are presented in section VI.

## II. Related Work

According to Deaf Association of Pakistan, almost 0.2 million people are deaf in Pakistan [1]. Likewise, there is a considerable percentage of people in other countries of the world who are unable to speak and thus cannot keep up with the technological world as there are almost 72 million deaf people around the globe according to the World Federation of the deaf [2].

Sign language translation is a hot topic to assist disable persons so they can compete in outer world. Two major techniques are the use of Vision based pattern recognition system of gestures which consists of a laptop and a single board computer along with a camera [3][4]. Signs are made in front of the camera which are processed using different techniques majorly including Digital Image Processing to achieve the desired outputs. Second technique is the use of a glove equipped with sensors on it. Our system is based on the later technique.

There are some limitations in vision based techniques which has to be considered before choosing this approach. In approach of Digital Image Processing, a camera has to be interfaced with a Single Board Computer or Laptop that can restrict an device to be wearable as compared to a glove [4]. And accuracy of an image processing algorithm can be reduced in case of classifying the signs that are similar in orientation or posture [5]. Light condition of environment also effects the accuracy of an image processing algorithm[6].

A pattern recognition system based on Digital Image Processing is presented in [3]. The apparatus captured the gestures continuously and converted them to audio signals and vice versa. That system was neural network based and was divided into Training and Testing phases. Continuous live images were captured through the camera which are further processed in MATLAB, segmented and trained through Feed Forward Neural Network. The corresponding output was displayed after the gesture was recognized by pattern recognition of the Neural Network. To increase accuracy of a neural network based approach, a large dataset of signs can contribute to increase accuracy of system [4][5].

Hanine El Hayek et al presented a hand glove based sign to letter translator system. The output of the signs made by wearing the glove was displayed on an LCD. The system consisted of a number of flex sensors which provided the change in their resistances, a microcontroller to process these values and an LCD to show the respective results [7].

Kehkashan Kanwal et al used an instrumented wearable glove to translate Pakistani Sign Language. They used Principle Component Analysis (PCA) which was employed for extraction of different features and Euclidean Distance (ED) for classification of signs. They attempted to translate 10 signs of the language and achieved the accuracy of around 90% [8].

Monitoring using a sensor based glove of rehabilitation finger movements of one hand is presented by M. Borghetti et. However, only one flex sensor out of ten was tested due to compulsion of low power consumption. Also the system required a lot of hardware to carry the experimentations [9].

The implementation of a sign language teaching program using a hand glove is discussed in [10]. They provided two different selectable modes through a switch. One is the teaching mode in which a database was created by entering hand position corresponding to ASL. Other is the learning mode, in which the signer is supposed to make the signs and then they were compared with the existing database. Moreover, the system was provided with a keypad containing switches to select the hand positions programmed before.

Enable talk- A glove which used sensors and smart phone to recognize gestures is presented in [11]. It won Microsoft Imagine Cup in 2012.

CyberGloves are widely used for translating different sign languages. Mohamed A. Mohandes used 56 sensors on two CyberGloves to get the values of each hand gesture. Principle Component Analysis and Support Vector Machine were used for feature extraction and classification respectively [12].

## III. Methodology

The design of the system can be easily understand by the flow chart as shown in Fig 2.

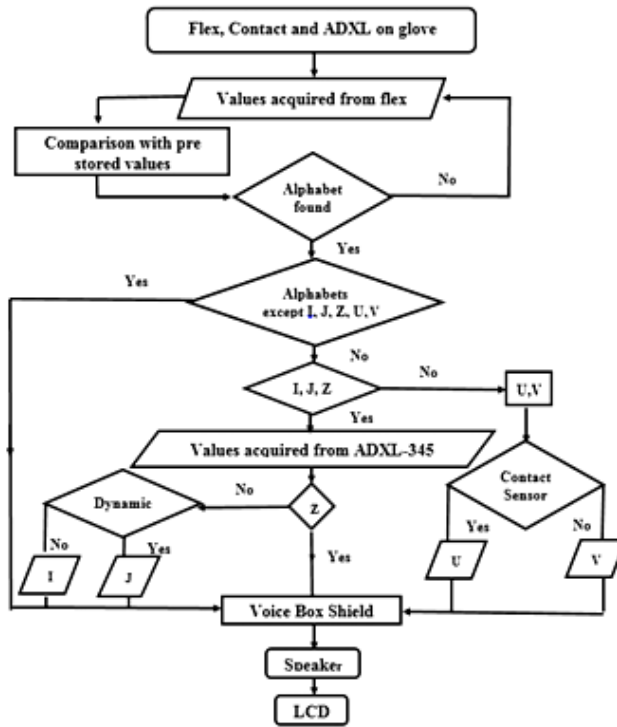

Fig 2 Flow Chart

The main source of input for the device is the flex sensor values as they are basically representing the signs. They are placed on each finger of the glove and results in variation of their resistance when fingers are bent. This variation of resistance is converted into voltage which is then processed by the microcontroller after performing A/D conversion. These values of flex sensors are then compared with the predefined range in the controller which has been set after carrying out a series of experiments. If all the values for a particular sign lies in the range defined for that sign, that alphabet is displayed on LCD and also it is available on the speaker after being processed through the voice box shield.

Few signs are dynamic. For these signs, accelerometer has been utilized. They are detected by difference in the axes. Two signs ‘U’ and ‘V’ have almost the same range of flex values. The only thing that differentiates them is the contact between index finger and middle finger. For this purpose, contact sensor is designed. Two conductive foils are placed on the index and middle finger of the glove to make contact. Power is supplied on one finger and the status of the other coil is checked continuously.

#### iv. Hardware Used For Implementation Of System

The main components of this device includes a hand glove, flex sensors, accelerometer, voice box shield, contact sensors, 12V battery and an Arduino Mega 2560 (AtMega 2560 microcontroller) for processing purposes.

##### A. Flex Sensors

To recognize sign, specific shape and orientation of the body parts is required to detect. Bending of a user’s finger can be measured using output of flex sensors as shown in Fig 3. Flex sensor is a resistive sensor whose resistance varies according to its bending [13]. Value of resistance is directly proportional to the flexion of sensor.



Fig 3 Flex Sensor for detecting Orientation and Shape of Sign

A flex sensor can be used in voltage divider configuration as shown in Fig 4. Output of this configuration is fed to Analog to Digital Convertor. It is required to consider signal conditioning for protection of ADC and accurate output.

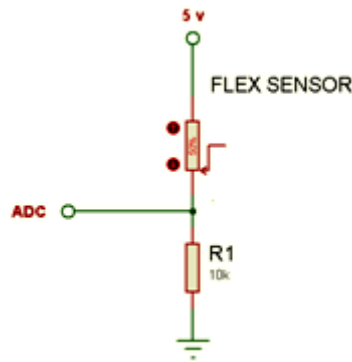

Fig 4 Flex Sensor to Provide Output to ADC

ADC which is used in this system can take maximum of 5 volts as input. So, input voltage of 5 volts is used for voltage divider configuration. It is to ensure that as the value of flex sensor varies with bending, it should provide an output voltage of range 0 to 5 volts with the help of fix resistor as refers to (1).

$$V_{ADC} = [R_{flex} / (R_{flex} + R_{in})] * V_{in} \quad (1)$$

### B. Arduino Mega

The Arduino Mega 2560 board is used as controller. It has Atmega 2560 as microcontroller as shown in Fig 5. It provides 54 digital pins for taking digital inputs and displaying or controlling digital devices. It also has 16 analog inputs. This board has crystal frequency of 16 MHz. It can be directly powered by battery to get started which makes it suitable for portable devices.



Fig 5 Arduino Mega 2560

Output of flex Sensor VADC is fed to Analog input of Arduino Mega 2560. ADC in this board is of 10 bit Resolution and can take value between 0 and 5 volts. Equation (2) is the formula for Step Size. Maximum value supported by ADC is 5 volts and resolution of ADC is 10 bits. So step size of ADC for Arduino Mega is 0.00488 (5 milis).

$$\begin{aligned} StepSize &= [V_{max} / (2^{Res\_Bits})] \\ StepSize &= [5 / (2^{10})] \end{aligned} \tag{2}$$

This ADC is of 10 bits, so all values of input (0 to 5v) would be converted to range of 0 to 1023. In case of 5V input, output would be 1023 and in case of 2.5 volts input, output would be 512 according to (3).

$$D_{out} = [V_{ADC} / (Step\_Size)] \tag{3}$$

These digital values would be used in database for detecting specified sign.

### C. Accelerometer (ADXL345)

Accelerometer ADXL-345 is used in this work. Purpose of accelerometer in this work is to distinguish between the static and dynamic signs (I, J and Z alphabets). Signs like I, J and Z are not only based on finger orientation, but also a specific movement is required to build these signs. These type of signs are called dynamic signs. Accelerometer is a low powered, small and thin, 3-axis MEMS accelerometer as shown in Fig 6. It is used in tilt-sensing applications. Less than 1.0 degrees change in the inclination angle can be measured due to its high resolution i.e.4 mg/LSB.

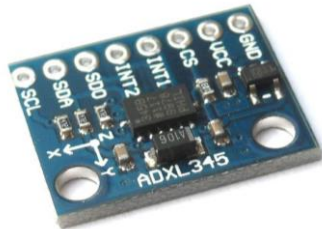

Fig 6 Accelerometer to measure Static and Dynamic Signs

### D. Contact Sensors

Sign of alphabet “U” and “V” have same orientation, as shown in Fig 7. so the value of resistances of the flex sensors will be same in both cases. Thus to distinguish alphabets U and V, a metallic part consists of the copper paper/foil is used. It is made by wrapping two separate copper foils on two different fingers. Voltage is supplied to only one foil to let current flow through it. Whenever it touches the other foil wrapped on the other finger, current flows through the other one too and thus it can be sensed as a contact among the two fingers. So when Arduino get high input from contact sensor, U is detected, else it is a V.



Fig 7 Alphabets U and V

### E. Voice Box Shield

The module can be fitted on top of Arduino board to give it away in to all of the functions of the speak Jet voice and sound as shown in Fig 8. The voice box shield uses the speak jet chip to convert serial commands into audible voice.

The electronics includes Speak Jet IC, an audio amplifier with two levels and a button to adjust the gain and output jack 3.5 mm standard audio integrated in the Voice Box Shield.



Fig 8 Voice Box Shield

### F. Final Prototype

Except the flex sensors and accelerometer, the complete circuitry is placed inside a rectangular box made from acrylic sheet.

A suitable hand glove is selected and one flex sensor is stitched on each finger as shown in Fig 9. Flex sensors of two different lengths were selected according to the size of the finger. Accelerometer, ADXL 345 is used to find the axes and orientation of the hand. It is placed on the back of hand glove.

Two conductive foils of silver are used on the index and middle finger to make a contact sensor.



Fig 9 Glove with Flex Sensors

To obtain audible output, voice box shield is used and is placed on the Arduino board. The complete prototype of the system along with the glove is shown in Fig 10.



Fig 10 Final Prototype

## v. Results

The experimental results of the flex sensor are elaborated below using different bending angles. Table I Specifies how voltages are varied when flex angle is changed from 10 to 90 degree with each step of 10 degrees. These results can also be validated by equation (1) and using a pull-up resistor of 10 K $\Omega$

TABLE I. VOLTAGE VARIATION WITH FLEX BENDING

FLEX BENDING (Degrees)	RESISTANCE OF FLEX (KΩ)	VOLTAGE ACROSS FLEX (V)
10	12.3	2.83
20	14.3	3.01
30	17	3.17
40	18.7	3.24
50	21.9	3.37
60	22.7	3.51
70	23.8	3.64
80	25	3.7
90	28.2	3.8

This shows the max voltage that can be dropped across the flex sensor when placed on the finger is 3.8 volts out of 5 volts being applied as input to the arduino board.

The flex are placed on fingers as s in Fig 11. The collected data for all alphabets is summarized in Table II. Note that the data is given in terms of digital range of 0-1023 corresponding to 0-5 volts in analog range of voltage values.

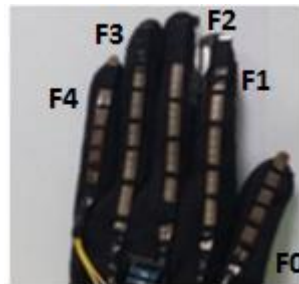

Fig 11 Order of Flex Sensors

TABLE II. COLLECTED DATA FOR ALL ALPHABETS

ALPHABETS	FLEX SENSORS				
	F0	F1	F2	F3	F4
A	242	198	317	331	158
B	270	460	527	558	288
C	221	301	417	448	252
D	175	416	353	354	167
E	186	206	345	360	164
F	196	233	520	556	280
G	252	330	295	313	146
H	203	371	494	331	153
I	203	199	343	352	280
J	203	199	343	352	280
K	250	377	446	366	179
L	247	400	308	333	168
M	212	212	351	368	203
N	239	214	351	389	171
O	167	239	364	371	168
P	258	410	450	366	165
Q	261	317	306	328	151
R	242	409	516	365	167

S	193	186	284	314	146
T	289	218	341	358	172
U	201	425	515	353	154
V	195	457	515	353	154
W	202	443	522	553	179
X	168	245	314	331	159
Y	253	187	320	342	278
Z	187	406	310	334	167

For checking the accuracy of the system, 10 samples of alphabet each were taken. The target was to check the repeatability of each sign. The results achieved can be analyzed from confusion matrix or error matrix given in Table III.

TABLE III. CONFUSION MATRIX TABLE

SI NO	SAMPLE ALPHABET	TRUE POSITIVE VALUE (%)	TRUE NEGATIVE VALUE (%)
1	A	100	0
2	B	100	0
3	C	80	20
4	D	100	0
5	E	100	0
6	F	90	10
7	G	100	0
8	H	100	0
9	I	90	10
10	J	70	30
11	K	100	0
12	L	90	10
13	M	100	0
14	N	100	0
15	O	100	0
16	P	80	20
17	Q	100	0
18	R	100	0
19	S	100	0
20	T	90	10
21	U	90	10
22	V	100	0
23	W	100	0
24	X	100	0
25	Y	100	0
26	Z	90	10

## vi. Conclusion

The design and implementation of sign language interpreter is discussed in this paper which is a hand glove along with some sensors and circuitry placed on the arm of the person wearing it for making signs. The main objective of this device is to detect the change in gestures and convert them into human understandable form to fill the communication gap between deaf/mute and normal people. The designed system is portable, safe to use, can be easily installed and above all it is affordable enough to help every individual who can't speak or hear.

The system can be upgraded easily for more understandable conversation by making use of other sensors like gyroscopes along with the already used accelerometer. This will help to judge the orientations of signs in a better way. Also it can be further enhanced to work on continues speech synthesis. Wireless communication can be done with some modifications in the design.

## **Acknowledgment**

The authors would like to thank Professor Luciano Lavagno, DET, Politecnico Di Torino, for his valuable time and guidance.

## **References**

- [1] Deaf Statistics. Pakistan Association of the Deaf [Online] [Cited: 7 12, 2015]. Available: [http://www.padeaf.org/deaf\\_statistic.html](http://www.padeaf.org/deaf_statistic.html)
- [2] Deaf people and human right report. World Federation of Deaf Website. [Online] [Cited: 712,2015] Available: <http://www.wfdeaf.org>
- [3] Suganya R and Dr. T. Meeradevi, "Design of a Communication Aid for Physically Challenged," IEEE 2<sup>nd</sup> International Conference on Electronics and Telecommunication System, 2015. pp 818-822
- [4] Yaqoob Javed M., Syed Tahir Hussain Rizvi, Majid Gulzar M. and Zaineb Iqbal, "Implementation of Image Processing Based Digital Dactylogy Converser for Deaf-Mute Persons," IEEE International Conference on Intelligent Systems Engineering (ICISE), Jan 2016.
- [5] Yellapu Madhuri, Anitha .G and Anburajan .M, "Vision-Based Sign Language Translation Device," IEEE International Conference on Information Communication and Embedded Systems (ICICES), 2013
- [6] Matheesha Fernando and Janaka Wijayanayaka, " Low Cost Approach For Real Time Sign Language Recognition," IEEE 8th International Conference on Industrial and Information Systems, ICIIS, Aug. 18-20, 2013, Sri Lanka
- [7] El Hayek, Hanine and Jessica Nacouzi et al, "Sign to Letter Translator System using a Hand Glove," IEEE 3<sup>rd</sup> International Conference on e-technologies and Networks for Development (ICeND), 2014. pp 146-150
- [8] Kanwal, Kehkashan et al, "Assistive Glove for Pakistani Sign Language Translation," IEEE 17<sup>th</sup> International Multi-Topic Conference (INMIC), 2014. pp 173-176
- [9] Borghetti, M.; Sardini, E.; Serpelloni, M., "Sensorized Glove for Measuring Hand Finger Flexion for Rehabilitation Purposes," IEEE Transactions on Instrumentation and Measurement, vol.62, no.12, pp. 3308-3314, 2013
- [10] Kadam, Kunal et al, "American Sign Language Interpreter," IEEE 4<sup>th</sup> International Conference on Technology for Education (T4E), 2012. pp 157-159
- [11] Enable Talk. Enable Talk website. [Online] Available: <http://enabletalk.com>
- [12] Mohandes, Mohamed A. Recognition of Two-handed Arabic Signs using the CyberGlove. 2010. pp. 124-1
- [13] Simone, L.K., Elovic, E., Kalambur, U. & Kamper, D, "A Low Cost Method To Measure Finger Flexion In Individuals With Reduced Hand And Finger Range Of Motion," 26th Annual International Conference of the IEEE on Engineering in Medicine and Biology Society, 2004, pp. 4791 - 4794