

Novel Neural Architecture for Air Data Angle Estimation

*Original*

Novel Neural Architecture for Air Data Angle Estimation / Battipede, Manuela; Cassaro, Mario; Gili, Piero; Lerro, Angelo.  
- STAMPA. - 383:(2013), pp. 313-322. ( 14th International Conference, EANN 2013 Halkidiki, Greece 13-16 September 2013,).

*Availability:*

This version is available at: 11583/2515122 since:

*Publisher:*

Berlin; Heidelberg: Springer Verlag Germany

*Published*

DOI:

*Terms of use:*

This article is made available under terms and conditions as specified in the corresponding bibliographic description in the repository

*Publisher copyright*

(Article begins on next page)

# Novel Neural Architecture for Air Data Angle Estimation

Manuela Battipede, Mario Cassaro, Piero Gili, and Angelo Lerro

Politecnico di Torino, Corso Duca degli Abruzzi 24, Torino 10128, Italy  
{manuela.battipede,mario.cassaro,piero.gili,  
angelo.lerro}@polito.it

**Abstract.** This paper presents a novel architecture for air-data angle estimation. It represents an effective low-cost low-weight solution to be implemented in small, mini and micro Unmanned Aerial Vehicles (UAVs). It can be used as a simplex sensor or as a voter in a dual-redundant sensor systems, to detect inconsistencies of the main sensors and accommodate the failures. The estimator acts as a virtual sensor processing data derived from an Attitude Heading Reference System (AHRS) coupled with a dynamic pressure sensor. This novel architecture is based on the synergy of a neural network and of an ANFIS filter which acts on the noise-corrupted data, cancelling the noise contribution without interfering with the turbulence frequencies, which must be preserved as key information for the AFCS activity.

**Keywords:** Air-Data sensor, virtual sensor, analytical redundancy, ANFIS filtering.

## 1 Introduction

The increasing need of modern UAVs to reduce cost and complexity of on-board systems has encouraged the practice to substitute, whenever feasible, expensive, heavy and sometimes even voluminous hardware devices with executable software code. Virtual sensors can be used as voters in dual-redundant or simplex sensor systems, to detect inconsistencies of the hardware sensors and accommodate the sensor failures. This practice is commonly referred to as analytical redundancy. More generally, analytical redundancy identifies with the functional redundancy of the system.

The virtual sensor for air-data estimation presented in this paper is based on neural networks (NN) which are an extremely powerful tool to reduce the discrepancies between the mathematical model and the real plant, which is the main drawback of the majority of the model-based techniques. The current literature is rich of examples of NNs used as emulators to estimate aerodynamic coefficients [1], angle of attack [2], [3], and sideslip angle [4] from data derived from other sources that are not the classic vanes, differential pressure sensors or expensive modern multifunction probes. Many of them, however, rely on the dynamic pressure measure [5], [6], which represents a criticality, as the dynamic pressure is usually measured by external devices, which are not very suitable on modern UAVs: for example they might

M. Battipede et al.

interfere with the pilot camera angle of view or other payload sensors, or simply they might limit the UAV stealth capabilities. When the dynamic pressure signal is not directly required, it is calculated correlating information related to the center of gravity position, the engine torque and the actual thrust [7], which must be measured with great accuracy to provide the virtual air-data sensor with acceptable performance.

The neural Air-Data Sensors (ADS) presented in this paper is based on data derived from the Attitude Heading Reference System (AHRS) coupled with the dynamic pressure signal. AHRS consist of either solid-state or MEMS gyroscopes, accelerometers and magnetometers mounted in the orthogonal 3D frame. The key difference between an AHRS and an IMU, which simply consists of three angular rate sensors and three accelerometers, is the addition of an on-board processing system in an AHRS which provides also attitude and heading information.

A sensitivity analysis is performed to select the minimum data set to be included among the NN input variables. The effect of sensor accuracy is investigated. One of the most critical issues related to real applications, is quality of the flight data, which are usually noise-corrupted [8]. An ANFIS filter is thus developed to cut-off the sensor noise without interfering with the turbulence frequencies, which must be preserved as key information for the AFCS activity.

## 2 Sensitivity Analysis on Air-Data Angle Models

In respect to the definition of the aircraft body and wind axis reference system, as reported in Fig.1 the angle-of-attack and the sideslip angle can be expressed by the following relations:

$$\alpha = \tan^{-1} \frac{w}{u} \quad (1)$$

$$\beta = \tan^{-1} \frac{v}{\sqrt{u^2 + w^2}}$$

where  $u, v$ , and  $w$  are the body-axis component of the airspeed  $V$ . By differentiating the first equation and imposing the force equilibrium along the  $x$  and  $z$  body axes it is possible to find an explicit equations for  $\dot{\alpha}$ :

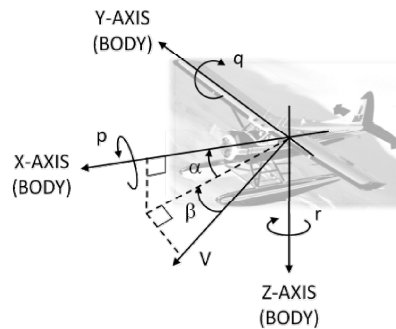

**Fig. 1.** Wind-axis and body-axis reference frames

## Novel Neural Architecture for Air Data Angle Estimation

$$\dot{\alpha} = \frac{\left( qu - pv + g_0 \cos \phi \cos \vartheta + \frac{F_z}{m} \right) \cos \alpha}{V \cos \beta} - \frac{\left( rv - qw - g_0 \sin \vartheta + \frac{F_x}{m} \right) \sin \alpha}{V \cos \beta} \quad (2)$$

where  $F_x$  and  $F_z$  are the resultant external forces along the x and z body axis, which accounts for the aerodynamic and propulsive contributions, including the pilot commands, given through the control surface deflections.  $\dot{\alpha}$  can be either integrated to obtain the angle-of-attack trend or used to infer it through a neural emulator, for example. In this context Eq. 2 is essential to understand the dependence of  $\alpha$  on the state and control variables. According to Eq. 2, namely, it is possible to reconstruct the  $\alpha$  signal through the measurements of a given set of variables:

$$\alpha = f_\alpha(q_c, a_x, a_z, \beta, \vartheta, \phi, p, q, r, \delta_f) \quad (3)$$

where the dynamic pressure  $q_c$  is representative of the total speed  $V$ . In Eq. 6 the contribution of the external forces  $F_x$  and  $F_z$  have been substituted by the accelerations  $a_x$  and  $a_z$  respectively, which are measured by the on-board accelerometers, under the assumption that the AHRS platform is located in the close proximity of the aircraft centre of gravity, and aligned with the body axes. Eq.6 has been extended to include the effects of flaps which can considerably change, if extracted, the aerodynamic configuration during the take-off, approach and landing phases.

Eq. 2 takes into account the contribution of a very wide set of variables under the assumption that they can be measured and adequately filtered to reconstruct a signal for the angle-of-attack, which can be used with a high level of confidence for purposes of guidance and control of the aircraft. The high number of variable involved, though, suggests that a further analysis can be conducted to investigate the actual necessity of including all the variables and the impact of each of them on the angle-of-attack estimation.

The sensitivity analysis can be performed in different ways depending on the flight condition characteristics: steady flight, for example, can be analyzed through a local method involving the linearization of the equations of motions:

$$f(\dot{X}, X, U) = 0 \quad (4)$$

where  $X$  and  $U$  are respectively the state and control variables and  $f$  indicated the implicit nonlinear body-axis first order differential equations of motion. Linearization around the steady condition implies calculating the partial derivatives of each equation with respect to each variable:

$$\nabla_{\dot{X}} f \cdot \delta \dot{X} + \nabla_X f \cdot \delta X + \nabla_U f \cdot \delta U = 0 \quad (5)$$

where  $\nabla$  represents a row vector of first partial derivative operators.

M. Battipede et al.

Analytical and numerical investigations reveal that, under the specific assumption that the stability-axis inertia matrix  $J_s$  is symmetric, the longitudinal and lateral-directional equations are decoupled [18]. This implies that  $\dot{\alpha}$  is affected mainly by the longitudinal variables  $q_c, a_x, a_z, q, \theta$  and  $\delta_f$  among which the least influential term is the pitch angle  $\theta$ .

In unsteady conditions the non linear dynamic equations must be considered and the sensitivity analysis can be performed through the uncertainty propagation method, which assumes independence among the measured variable: test manoeuvres are simulated in the time-domain and the sensor signal  $y$  is modelled assuming that the uncertainties have a Gaussian standard probability distribution, where the root mean square deviation is given by the sensor accuracy. For the sake of generality, in the present analysis accuracy is given as a percentage of the full scale range of each sensor and comparison is carried out considering the same accuracy percentage for each sensor. Indeed, the accuracy is a specific characteristic of the particular sensor, which is declared by manufacturers in terms of non-linearity, temperature and hysteresis effects. The uncertainty analysis performed in unsteady conditions on all the variables included in Eq.2 reveals that the angle-of-attack errors resulting from the inaccuracy propagation of  $q_c$  and  $a_z$ , considered separately, are one order of magnitude greater than the errors caused by all the other variables. Inaccuracy of the lateral-directional variables does not affect the angle-of-attack estimation. Eq. 8, thus, can reduce to the following relation:

$$\alpha = f_{\alpha}(q_c, a_x, a_z, q, \delta_f) \quad (6)$$

The same analysis performed on the sideslip angle leads to the following relation:

$$\beta = f_{\beta}(q_c, a_y, a_z, p, r) \quad (7)$$

### 3 Neural Air-Data Sensors

The implemented neural Air-Data Sensors (ADS) is made of two multi-layer perceptrons (MLP) network, one for the angle-of-attack and one for the sideslip angle, with a single non linear hidden layer containing 10 neurons and one linear output layer.

The single perceptron model was introduced and demonstrated by Rosenblatt [16], and it remains the simplest form of neural network, and it has been used as the smallest unit of the neural networks used for this work. Multilayer perceptron models were successfully applied in the past to solve several problems by means of training with very popular algorithms [12,19]. The single perceptron model is represented in Figure 2. It is generally characterized by one single output,  $y_j$ , one bias,  $b_j$ , and one activation function,  $f_j$ , which processes the signal,  $v_i$ . The variable  $v_i$  is the sum of the matrix product between a weight matrix,  $w_{ji}$ , and  $n$ -inputs,  $y_i$ . It is clear that the key-factors for the success of the single perceptron are the values of weight matrix coefficients. In order to obtain the best neural network weights, several optimization, or training algorithms exist [12,19] which have the aim to optimize the neural

## Novel Neural Architecture for Air Data Angle Estimation

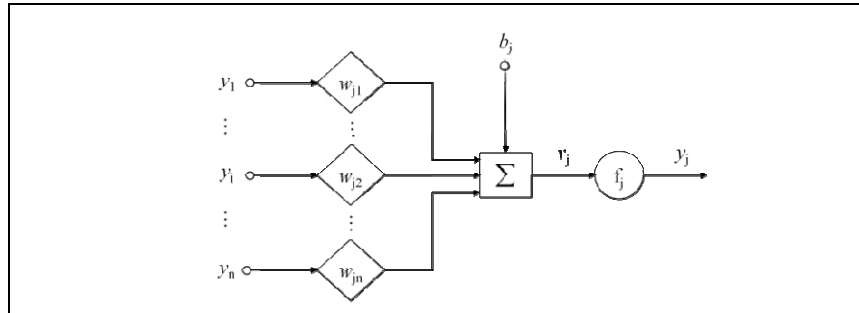

**Fig. 2.** Example of general neural perceptron with  $n$  inputs

network weights in order to minimize the error between the input-output pattern used for training. The learning algorithm used for this work has been the Levenberg-Marquardt algorithm [17,18].

To assess the validity of the model it has decided to simulate firstly the best-case scenario, training and testing the network on noise-free signals. Turbulence and noise have been addressed as occurring both separately and simultaneously. Performance are evaluated on the basis of  $\pm 1$  deg error specification.

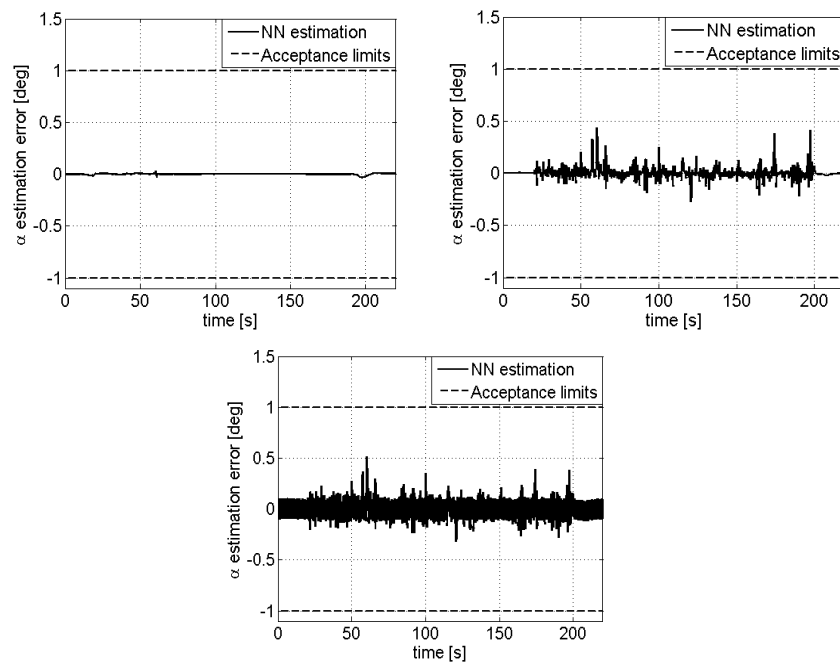

**Fig. 3.** Estimation error obtained using the test manoeuvre for the neural network NNA: (a) without turbulence and noise; (b) with turbulence and without noise; (c) with turbulence and noise.

M. Battipede et al.

The neural network acts as a time-invariant neural ARX (AutoRegressive with eXternal input)[10-11] predictor:

$$\hat{\alpha}(t, W) = g(\varphi(t), W) \quad (8)$$

(in the specific case of the angle-of-attack) where  $W$  is the vector containing the neural network parameters and  $\varphi$  is the regressor vector, characterized by zero input and output lag:

$$\varphi(t) = [q_c(t) a_x(t) a_z(t) q(t) \theta(t) \delta_f(t)] \quad (9)$$

This structure has the enormous advantage of being light in terms of computational resources as the estimation of  $\alpha(t)$  is performed without using any memory delay, processing only the variables at the current time step  $t$ . From now on, neural networks will be identified as NNA, if designed for the angle-of-attack estimation  $\alpha$ , and NNB, if designed for sideslip angle  $\beta$ .

As shown in Fig 3 and 4, the optimal response is obviously obtained in the noise-free situation (a), where the maximum peak to peak error is less than  $0.1 \text{ deg}$ . The estimation is progressively less accurate, when the signal is corrupted by turbulence and noise (b or c). The estimation error of  $0.5 \text{ deg}$  for the worst condition demonstrates high sensitivity of the network to the external noise.

The comparison of performance obtained on noise-corrupted signal suggest that data should be filtered before being fed to the neural air data sensors.

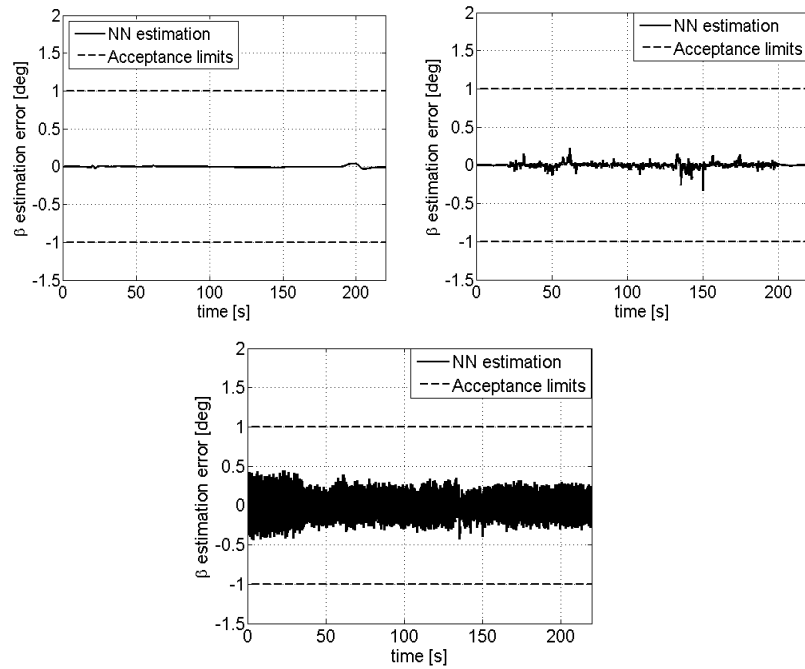

**Fig. 4.** Estimation error obtained using the test manoeuvre for the neural network NNB: (a) without turbulence and noise; (b) with turbulence and without noise; (c) with turbulence and noise

## 4 ANFIS Filter Design

An Adaptive Neuro Fuzzy Inference System (ANFIS) [12] is proposed for filtering the signals generated from the AHRS, which must be used as inputs for the neural virtual sensor. Small UAVs can be a challenging application as they represent an environment where the spectrum of noise vibrations and aircraft dynamic frequencies can overlap in several flight conditions. Conventional filters used for noise rejection and based on the Fast Fourier transform technique, usually introduce time delays, as they tend to affect the phase signal. However, even small time delays sometimes can be unacceptable, especially when the signal is fed to an artificial flight control system [13].

ANFIS filters reported in literature [14-15], are based on the knowledge of the noise affecting the signal. The membership functions of the input variables are usually trained using the noise-corrupted signals whereas the noise-free filtered signal is used to optimize the output part. Noise-free signals can be obtained by a classical post-processing method, based on an off-line signal re-phasing. Once it is trained, the ANFIS is able to associate a noise-corrupted signal to a noise-free one and to act as an on-line filter. Filtering is performed without introducing delay, besides the one brought about by the discretization process.

Performance, however, can deteriorate considerably if the input signal exceeds the universe of discourse, or, strictly speaking, if the amplitude and frequency of the input signal are not included among the examples of the training domain. For this reason it is important to identify the sources of noise that must be filtered, together with the range of the characteristic parameters. AHRS signals can be affected by several noise sources such as the electronic one, typical of each sensor, and the one introduced by the structural vibrations, typical of the installation. The latter may vary as a function of the structure architecture, of the installed propulsion system and of the flight condition which implies a certain degree of aerodynamic unsteadiness.

It is important to notice that oscillations due to turbulence shall not be filtered as they are key information to reconstruct the air-data angle signals. Turbulence conditions, in fact, require a more intensive autopilot control action and, for this reason, the signals used as feedback for the control law (i.e.  $\alpha$  and  $\beta$ ) must contain all the relevant information.

The  $a_x$ ,  $a_y$  and  $a_z$  acceleration signals are processed by 3 MISO ANFIS filters, one for each acceleration sensor. Each filter receives two different input signals: the first, coming from the AHRS, contains the measured noisy acceleration  $a_M$ ; the second, coming from the vibration sensor, is used to characterize the signal noise  $w_M$ .

The vibration sensor must be secured to the structure in the AHRS platform proximity, in case the noise is generated by structural vibrations that are not naturally cancelled by the AHRS platform dampers. Otherwise, the vibration sensor can be located close to noise source, such as the propulsion system.

In detail, each acceleration ANFIS filter, uses a hybrid learning algorithm to optimize the membership function parameters of a Takagi-Sugeno type fuzzy inference systems, each of which has a proper universe of discourse, imposed by the aircraft flight performance. As an example the  $a_z$  component of the aircraft under analysis ranges  $\pm 2g$  from the level flight condition, and 7 bell-shape membership

M. Battipede et al.

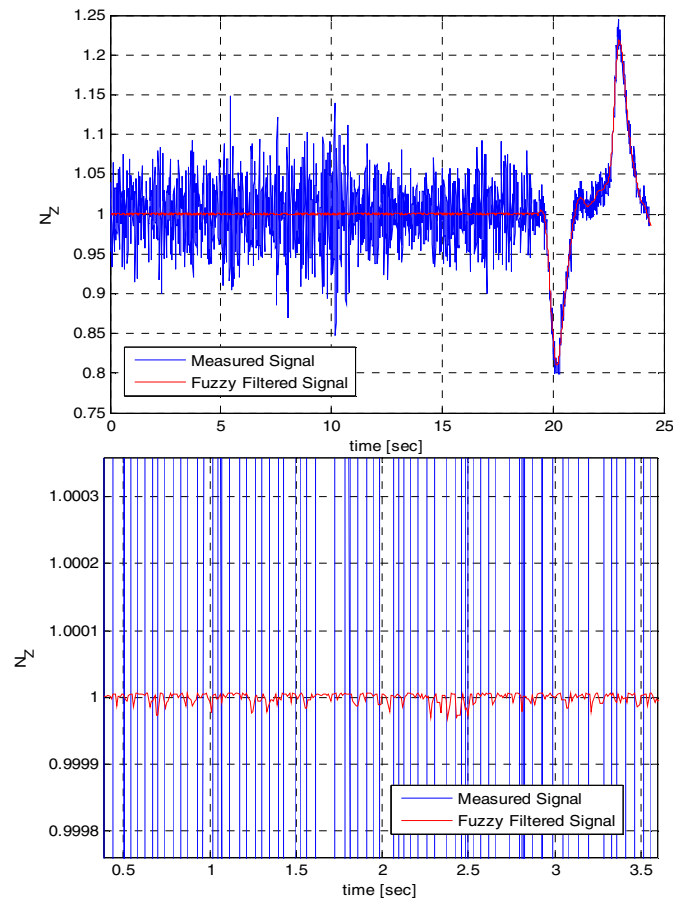

**Fig. 5.** (a) Comparison between measured and filtered  $n_z$  during take-off; (b) Zoom for error evaluation

functions, plus 2  $z/s$ -shape at the boundary, were used to discretize the input domain. The filtered signal used to train the membership function parameters was obtained by re-phasing a third order Butterworth filter result.

To test the filter performance a take-off manoeuvre, registered for a small UAV was used, just after a short training conducted with data representative of the whole flight envelope.

The first nineteen seconds of Figure 5 refer to the ground run and are characterized by strong vibrations due to the gear loads which sum up to the structural vibrations induced by the propeller. From the take-off onwards only aerodynamic and structural loads are captured by the accelerometer. Globally, the maneuver is characterized by a wide variation of the noise characteristics, but the ANFIS filter shows its ability to cut off undesirable frequencies with no appreciable delay other than the sampling time.

## 5 Conclusion

A neural Air-Data Sensors has been presented, based on data derived from the Attitude Heading Reference System (AHRS) coupled with the dynamic pressure signal. Accelerometer signal are commonly noise-corrupted and needs an accurate filtering process to cut-off the sensor noise without interfering with the turbulence frequencies, which must be preserved as key information for the AFCS activity.

The ANFIS filter has proven effective to provide the neural network with noise-free data for the real time on-board estimation of the air-data angles, without introducing time delays. The ANFIS filter is based on the knowledge of the noise affecting the signal and its correct modeling. Even when the sources of undesirable noise have been correctly identified and included in the training domain, however, there might be a criticality, associated to a structural or propulsive failure, which might shift unpredictably the noise frequency beyond the filter notches, and deteriorate the filter performance. For this reason, before the virtual sensor can become commercially valuable, a quantitative hazard analysis should be performed to evaluate the impact of different sources of failure and implement the required mitigating factors.

## References

1. Norgaard, M., Jorgensen, C.C., Ross, J.C.: Neural Network Prediction of New Aircraft Design Coefficients. NASA Technical Memorandum 112197 (1997)
2. Oosterom, M., Babuska, R.: Virtual Sensor for the Angle-of-Attack Signal in Small Commercial Aircraft. In: IEEE International Conference on Fuzzy Systems (2006)
3. Samara, P.A., Sakellariou, F.J.S., Fassois, S.D.: Aircraft Angle-Of-Attack Virtual Sensor Design via a Functional Pooling Narx Methodology. In: Proceedings of the European Control Conference (ECC), Cambridge, UK (2003)
4. Xiaoping, D., et al.: A prediction model for vehicle sideslip angle based on neural network. In: IEEE Information and Financial Engineering (ICIFE), pp. 451–455 (2010)
5. Rohloff, T.J., Whitmore, S.A., Catton, I.: Air Data Sensing from Surface Pressure Measurements Using a Neural Network Method. AIAA Journal 36(11) (1998)
6. Samy, I., Postlethwaite, I., Green, J.: Neural-Network-Based Flush Air Data Sensing System Demonstrated on a Mini Air Vehicle. Journal of Aircraft 47(1) (2009)
7. McCool, K., Haas, D.: Neural network system for estimation of aircraft flight data, United States Patent 6.466.888 (2002)
8. Svobodova, J., Koudelka, V., Raida, Z.: Aircraft equipment modeling using neural networks. In: Electromagnetics in Advanced Applications, ICEAA (2011)
9. Roskam, J.: Airplane Flight Dynamics and Automatic Flight Controls, Design, Analysis and Research Corporation, Lawrence, KS (2001)
10. Narendra, K.S., Parthasarathy, K.: Identification and Control of Dynamical Systems Using Neural Networks. In: Proceedings of the IEEE First Annual International Conference on Neural Networks, vol. 1(1), pp. 4–27 (1990)
11. Chen, S., Billings, S.A.: Neural Networks for Nonlinear Dynamic System Modeling and Identification. In: Advances in Intelligent Control, pp. 85–112. Taylor and Francis (1994)

M. Battipede et al.

12. Jang, Sun, Mizutani: Neuro- fuzzy and soft computing: a computational approach to learning and machine intelligence. Prentice-Hall, Upper Saddle River (1997)
13. Rohac, J., Reinstein, M.L., Draxler, K.: Data Processing of Inertial Sensors in Strong-Vibration Environment. In: 6th IEEE International Conference on Intelligent Data Acquisition and Advanced Computing Systems, Technology and Applications (2011)
14. He, Y., Manful, D., Bárdossy, A.: Fuzzy Logic Based De-Noising of Ultrasound Signals From Non- destructive Testing. *Otto-Graf-Journal* 15 (2004)
15. Balaiah, P., Ilavennila: Comparative Evaluation of Adaptive Filter and Neuro-Fuzzy Filter in Artifacts Removal From Electroencephalogram Signal. *American Journal of Applied Sciences* 9(10), 1583–1593 (2012)
16. Rosenblatt, F.: The perceptron: A probabilistic model for information storage and organization in the brain. *Psychological Review* 65(6), 386–408 (1958)
17. Levenberg, K.: A method for the solution of certain problems in least squares. *Quart. Applied Math.* 2, 164–168 (1944)
18. Marquardt, D.W.: An algorithm for least-squares estimation of nonlinear parameters. *SIAM Journal on Applied Mathematics* 11(2), 431–441 (1963)
19. Galushkin, A.I.: *Neural Networks Theory*. Springer (2007) ISBN 978-3-540-48124-9