

Wheelchair.q, a motorized wheelchair with stair climbing ability

*Original*

Wheelchair.q, a motorized wheelchair with stair climbing ability / Quaglia, Giuseppe; Franco, Walter; Oderio, Riccardo. -  
In: MECHANISM AND MACHINE THEORY. - ISSN 0094-114X. - 46:(2011), pp. 1601-1609.  
[10.1016/j.mechmachtheory.2011.07.005]

*Availability:*

This version is available at: 11583/2486996 since:

*Publisher:*

elsevier

*Published*

DOI:10.1016/j.mechmachtheory.2011.07.005

*Terms of use:*

This article is made available under terms and conditions as specified in the corresponding bibliographic description in the repository

*Publisher copyright*

(Article begins on next page)

# Wheelchair.q, a motorized wheelchair with stair climbing ability

Giuseppe Quaglia\*, Walter Franco, Riccardo Oderio  
Politecnico di Torino, Department of Mechanics, Turin, Italy

## ABSTRACT

The paper deals with Wheelchair.q, a concept for a stair climbing wheelchair capable of moving in structured and unstructured environments, climbing over obstacles and going up and down stairs.

The design of the wheelchair, consisting of a frame, a seat and a four-bar linkage mechanism that connects frame and seat, is presented.

The four-bar linkage moves and rotates the chair to prevent the wheelchair from overturning and to guarantee a comfortable posture to the passenger during different operations. The kinematic synthesis of the linkage mechanism is discussed using an algebraic method. When the wheelchair faces an obstacle such as a step or a stair, it can passively change locomotion mode, from rolling on wheels to walking on rotating legs, thanks to its self-adaptive locomotion units. The function of the locomotion unit is described and modeled using kinematic equations. The locomotion unit requires only one motor, for both wheeled and legged locomotion. Tests on a scale prototype were conducted in order to

### *Keywords:*

Wheelchair  
Stair climbing  
Environment adaptation  
Wheel-legged locomotion  
Triple wheels Architectural  
barriers

## 1. Introduction

A civilized society must guarantee fair living conditions for all its members, including disabled people. Over the past few years, changing attitudes have made society more sensitive to this issue.

Mobility is the most common problem for disabled people, a problem that the introduction of power wheelchairs has done much to alleviate. However, a power wheelchair is useless when confronted with an architectural barrier. For this reason, a number of wheelchairs with stair climbing ability have been developed.

Some of them use tracks, as in [1]: these power wheelchairs consume a great deal of energy, compared to power wheelchairs. In addition they are heavy, approaching and leaving stairs are quite dangerous and slippage, when steering, is unavoidable. Some other solutions adopt a wheel-track locomotion system, as in [2] or in the TopChair [3]: these designs use a track system only for off-road and stair-climbing operations, using wheels on ground. Though approaching and leaving continue to be a problem, these wheelchairs are more efficient than previous solutions, in terms of energy consumption. Other solutions, such as the iBot [4], adopt a hybrid locomotion system whose major drawback is the high cost required to achieve reasonable safety standards. A more highly evolved device, presented in [5], uses a specific climbing mechanism for step climbing operations and wheels for on-road motion: this solution is lighter than wheel-track wheelchairs and has no problems in approaching and leaving stairs, but still requires a large number of actuators. At present no commercial device has conquered the market and climbing over barriers continues to be a major problem for the disabled.

The stair climbing wheelchair presented in this paper was developed from the authors' research in the Epi.q project. This project designed and built robots capable of moving on and off-road in structured and unstructured environments, going up and down stairs and climbing over obstacles. Thanks to their auto-adaptive locomotion units, which have a "wheel-leg" design, these robots can passively change their locomotion mode when they encounter an obstacle, from rolling on wheels to walking on.

\* Corresponding author.

E-mail addresses: giuseppe.quaglia@polito.it (G. Quaglia), walter.franco@polito.it (W. Franco), riccardo.oderio@polito.it (R. Oderio).

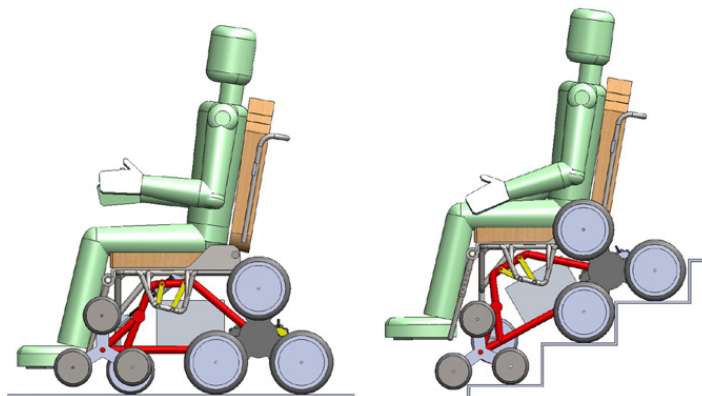

Fig. 1. Wheelchair.q on flat terrain and on stairs.

rotating legs, doing so in accordance with local friction and dynamic conditions. The first prototypes, Epi.q-1.1 and Epi.q-1.2, are described in [6] and a further development, called Epi.q-2, is presented in [7].

The locomotion unit implemented in Epi.q-2 has now been adapted to the stair climbing wheelchair, thus providing an effective alternative to existing solutions that can improve disabled mobility, as described in [8].

This paper presents an evolved version Wheelchair.q, a motorized wheelchair with climbing ability. The paper is organized as follows: Section 2 presents the wheelchair design, Section 3 investigates a linkage mechanism, and Section 4 provides a description of the locomotion unit and the different kinds of locomotion. Conclusions are illustrated in Section 5.

## 2. Wheelchair design

Wheelchair.q, shown in Fig. 1, is a concept for a stair and step climbing wheelchair.

As can be seen from the figure, the wheelchair consists essentially of three elements: a frame, a seat and a linkage mechanism connecting frame and seat. Using only one motor and transmission system per locomotion unit, the wheelchair passively changes its locomotion, from rolling on wheels (“advancing mode”) to walking on legs one (“automatic climbing mode”), simply on the basis of local friction and dynamic conditions.

### 2.1. Frame

The frame, shown in Fig. 2, consists of a chassis (1, red) that carries two motorized locomotion units (2) (described in detail Section 3), a support (3) for two electrical gear-motors (4), two idle triple wheels units (5) and a battery pack (6).

The chassis consists mainly of two tubular structures (a) connected by means of crossbars (b); two triangular tubular structures (c) on the front support the triple wheel units (5). This geometry provides space for stowing the pivoting wheel, shown in Fig. 3, when it is lifted up, and at the same time stiffens the structure against lateral forces. Connection points (d) are hinges for the linkage mechanism.

The triple wheel units (5) consist of a spider, rotating around a central axis, with three idle wheels placed at its vertices. Wheel size was chosen on the basis of the consideration that large wheels can better absorb vibrations caused by uneven terrain, while small wheels reduce overall dimensions. Accordingly, larger wheels were selected for the locomotion unit and for the pivoting wheel, which are in contact with the ground most of the time, while smaller ones were chosen for the triple wheel units, in contact

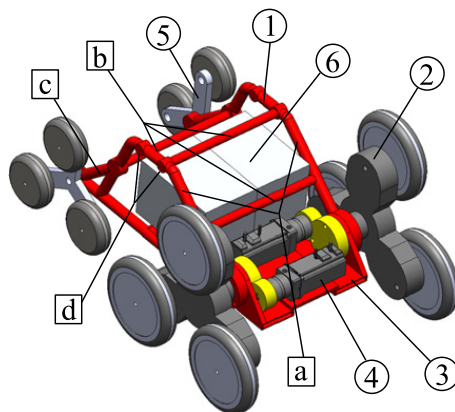

Fig. 2. The frame.

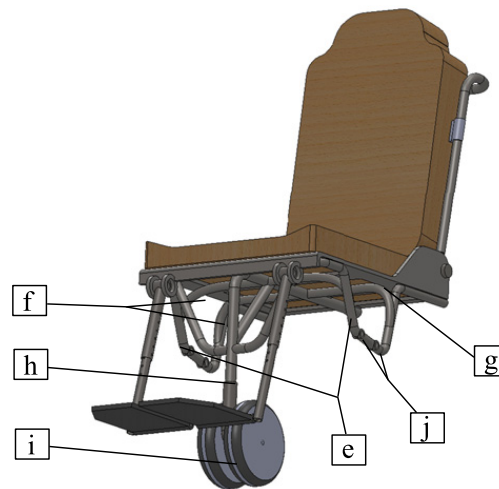

Fig. 3. The seat.

with the terrain only during stair climbing operations. The triple wheel unit design allows the wheelchair to climb over obstacles up to 210 mm high, as verified from simulations.

The gear-motors (4) are placed on a support (3), rigidly connected to the frame by means of screws, and the battery pack (6) is placed below the seat. The chosen gear-motors are 750 W units, with 1:64 gear ratio, though the chassis and support are designed to host gear-motors up to 1200 W.

## 2.2. Seat

The seat, shown in Fig. 3, is a tubular structure carrying a chair and a pivoting wheel.

The seat consists essentially of two tubular structures (e) connected by means of crossbars (f), a chair support (g) and a pipe (h) that ends with a pivoting wheel (i). Connection points (j), in tubular structure (e), are hinges for the linkage mechanism.

The seat can move relative to the frame: during stair climbing operations in fact the wheelchair is moved backwards and reoriented.

## 2.3. Linkage mechanism

The linkage mechanism generates relative motion between the frame and the seat.

During stair climbing operations it is required to accomplish three different tasks: moving the seat backwards, reorienting it and lifting up the pivoting wheel. When the seat is moved backwards, the center of mass of the wheelchair is placed in a safe position, and overturning is thus prevented. In addition, the seat is reoriented in order to guarantee a safe and comfortable posture for the passenger. Finally the pivoting wheel is lifted, to ensure contact between the two idle triple wheel units and the ground, as shown in Fig. 1.

In order to accomplish these tasks a four-bar linkage ( $A_0$ ,  $B_0$ ,  $A$ ,  $B$  and shown in Fig. 4) was chosen.

The linkage mechanism is actuated by a mini-motor (l) linked to an irreversible lead screw system (m). When the seat reaches the desired position the mini-motor can be switched off and no further energy is needed to maintain the position.

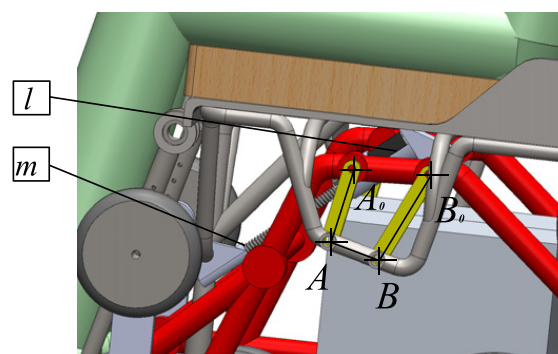

Fig. 4. The linkage mechanism.

Future plans call for providing the mini-motor with a closed loop control system for seat position and posture relative to the frame. The absolute inclination angle of the seat can be detected by sensors (redundant for safety reasons). This information, compared to the desired posture, would be the input for the control algorithm.

#### 2.4. Wheelchair operation

When the wheelchair moves on flat terrain the two locomotion units (2) and the pivoting wheel (i) are in contact with the ground, as shown in Fig. 5. Steering is accomplished by driving the two gear-motors at different speeds (differential steering).

In addressing the complex task of stair ascent or descent, the most important requirements are user security and stability. Taking into account these requirements, the following are necessary:

- a sufficiently large support base;
- an overall center of gravity positioned as low as possible;
- a wheelchair design that prevents any interference between the wheelchair, the user and the stairs.

These features involve climbing and descending stairs with the user's back facing the stairs.

When the wheelchair is going up or down stairs the locomotion units (2) and the idle triple wheel units (5) are in contact with the ground, while the pivoting wheel (i), integral with the chair, is lifted up. This configuration is comfortable for the passenger, because the seat posture is changed, and stable, because the center of mass is moved in a safe position. In addition, undesired steering is limited by local frictions between wheels and ground.

The trajectory of the locomotion unit central axis during stair-climbing operations is also controlled by the motor angular speed, in order to make the overall motion perceived by the wheelchair user comfortable and stable.

### 3. Linkage mechanism design

The four-bar linkage mechanism, as mentioned in Section 2, is required to accomplish three different tasks during stair climbing operations: moving the center of mass of the seat backward to prevent overturning, reorienting the seat so that the passenger has a comfortable posture, and lifting up the pivoting wheel so that the two idle triple wheel units and the ground make contact. To reduce energy consumption, the linkage mechanism is actuated by an irreversible system that can be switched off when the desired position is reached. The length of the links was also chosen with a view to reduce energy requirements. To this end, the mechanism moves and reorients the seat with a small rise in the seat's center of mass, as shown in Fig. 6.

#### 3.1. Four-bar linkage synthesis

Once the four-bar linkage mechanism was chosen, only its geometry had to be determined. Fig. 7 shows the four-bar linkage in an initial position (red) and in a generic position (green).  $A_0$  and  $B_0$  are hinges built into the frame, designated as (d) in Fig. 2.  $A$  and  $B$  are hinges fabricated in the seat, designated as (j) in Fig. 3.  $E$  is the center of mass of the seat, shown in Fig. 6.

Each link of a four-bar linkage can be represented in a complex plane, as described in [9] and in [10], using complex numbers. With respect to Fig. 7, a single link can be expressed as:

$$\vec{z}_1 = z_1 e^{i\theta_1} \quad (1)$$

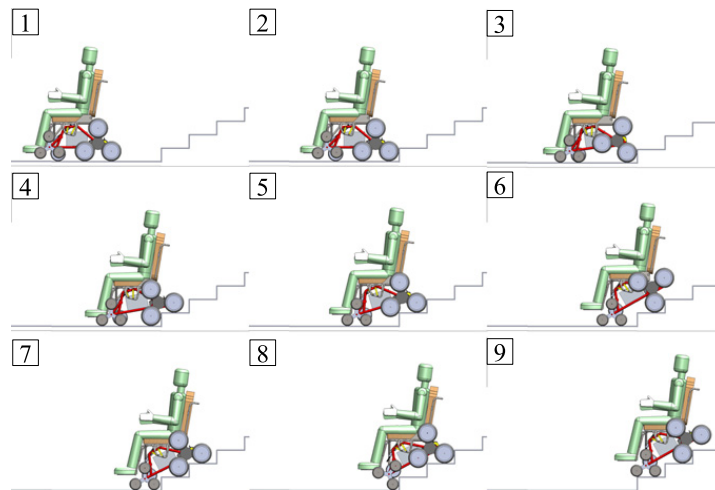

Fig. 5. Stair climbing sequence.

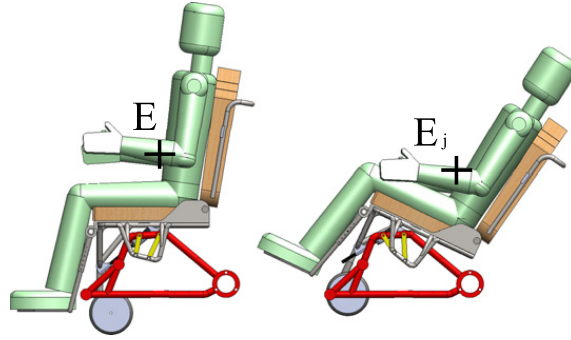

Fig. 6. Relative motion of the seat with respect to the frame; the seat center of mass is designated by the letter E.

which, after a rotation, becomes:

$$\vec{z}_{1j} = z_1 e^{i(\delta_1 + \alpha_j)} = \vec{z}_1 e^{i\alpha_j} \quad (2)$$

For a generic displacement of the four-bar linkage it is possible to write the following equations:

$$\vec{z}_1 + \vec{z}_5 + \vec{s}_j - \vec{z}_{5j} - \vec{z}_{1j} = 0 \quad (3)$$

$$\vec{z}_3 + \vec{z}_6 + \vec{s}_j - \vec{z}_{6j} - \vec{z}_{3j} = 0 \quad (4)$$

which can be rewritten as:

$$\vec{z}_1 \cdot (e^{i\alpha_j} - 1) + \vec{z}_5 \cdot (e^{i\beta_j} - 1) = \vec{s}_j \quad (5)$$

$$\vec{z}_3 \cdot (e^{i\gamma_j} - 1) + \vec{z}_6 \cdot (e^{i\beta_j} - 1) = \vec{s}_j \quad (6)$$

where  $s_j$  is the displacement of point E. If  $\alpha_j$ ,  $\beta_j$  and  $\gamma_j$  are known, the above problem becomes linear and only two more equations are needed. These new equations come from a further displacement of the four bar linkage.

The wheelchair problem consists of moving the seat backwards and rotating it. This means moving the point E to a suitable position ( $s_j$ ) and, at the same time, rotating the  $z_2$  link by an appropriate angle ( $\beta_j$ ), as shown in Fig. 7. Thus, if two displacements are chosen, for example an intermediate position between initial and final position, the problem can be expressed as follows:

$$\begin{bmatrix} e^{i\alpha_1} - 1 & e^{i\beta_1} - 1 \\ e^{i\alpha_2} - 1 & e^{i\beta_2} - 1 \end{bmatrix} \begin{Bmatrix} \vec{z}_1 \\ \vec{z}_5 \end{Bmatrix} = \begin{Bmatrix} \vec{s}_1 \\ \vec{s}_2 \end{Bmatrix} \quad (7)$$

$$\begin{bmatrix} e^{i\gamma_1} - 1 & e^{i\beta_1} - 1 \\ e^{i\gamma_2} - 1 & e^{i\beta_2} - 1 \end{bmatrix} \begin{Bmatrix} \vec{z}_3 \\ \vec{z}_6 \end{Bmatrix} = \begin{Bmatrix} \vec{s}_1 \\ \vec{s}_2 \end{Bmatrix} \quad (8)$$

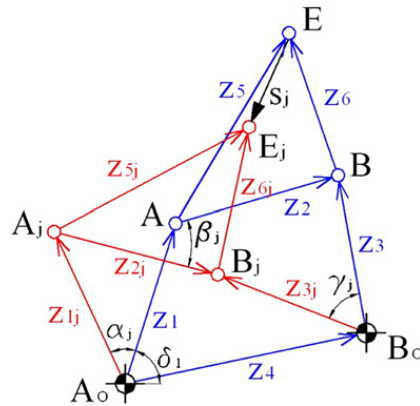

Fig. 7. The four-bar linkage in an initial position (red) and in a generic -j position (green).



**Table 2**  
Wheelchair.q locomotion unit nomenclature.

Element	Symbol	Radius	Rot. speed	Label
Frame				0
Gear motor	$M$		$\omega_M$	1
Planet carrier			$\Omega$	2
Solar gear	$s$	$r_S$	$\omega_S$	3
First planet gear	$PG1$	$r_{PG1}$	$\omega_{PG1}$	4
Second planet gear	$PG2$	$r_{PG2}$	$\omega_{PG2}$	5
Wheel	$W$	$r_W$	$\omega_W$	6

Each type of locomotion can be described using two kinematic equations that can be gathered from the description of the mechanical gearing operation. One equation is valid for all operating conditions, since it represents the meshing condition in the epicyclic gearing:

$$\frac{\omega_W - \Omega}{\omega_M - \Omega} = -\frac{r_{PG1}}{r_{PG2}} \cdot \left( -\frac{r_S}{r_{PG1}} \right) = k_e \quad (13)$$

The other equation, which describes the physical constraints introduced by local and dynamic conditions, is different for each locomotion mode.

The system of these two equations univocally determines the robot kinematics, as will be explained in the following subsections.

#### 4.1. Advancing mode

During “advancing mode”, robot weight and the reaction forces due to the contact between wheels and ground constrain the angular position of the locomotion unit; when the robot is moving on flat ground, planet carrier rotation is hindered:

$$\Omega = 0 \quad (14)$$

and the gear ratio  $i_A$  of the locomotion unit and the robot linear velocity  $v_A$  (see Fig. 9) can thus be expressed as:

$$i_A = \frac{\omega_W}{\omega_M} = \frac{r_S}{r_{PG2}} = k_e \quad (15)$$

$$v_A = \omega_W \cdot r_W = \omega_M \cdot k_e \cdot r_W \quad (16)$$

#### 4.2. Automatic climbing mode

When the torque required by the motor for the “advancing mode” exceeds a limiting value, the “automatic climbing mode” is triggered. For example, when moving in a structured environment, the wheelchair can climb over an obstacle when it bumps against a step and the local friction due to the contact between wheel and obstacle is sufficient to block the wheel. In this case front wheel and second planet gear rotation are hindered and planet carrier rotation starts as a result. The locomotion unit then rotates around the stopped wheel (see Fig. 9) and the wheelchair can climb over the obstacle:

$$\omega_W = \omega_{PG2} = 0 \quad (17)$$

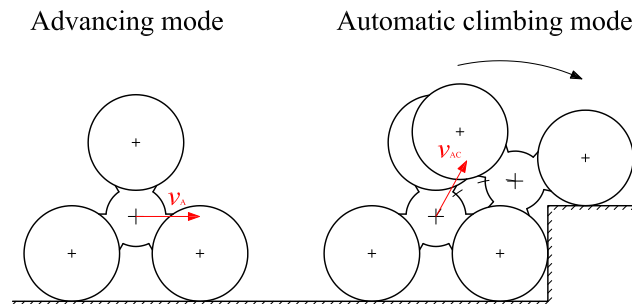

**Fig. 9.** Locomotion unit during step climbing operation.

During “automatic climbing mode”, locomotion unit gear ratio  $i_{AC}$  and the wheelchair linear velocity  $v_{AC}$  (see Fig. 9) can be expressed as:

$$i_{AC} = \frac{\Omega}{\omega_M} = \frac{k_e}{k_e - 1} \quad (18)$$

$$v_{AC} = \Omega \cdot l_L = \omega_M \cdot \frac{k_e}{k_e - 1} \cdot l_L \quad (19)$$

Planet carrier geometry is such that it reduces the risk of interference between obstacles and locomotion units. Nevertheless, interference can sometimes occur, especially during “automatic climbing mode”. Even in such cases, however, the wheelchair can climb over an obstacle with a motion that combines advancing and automatic climbing mode.

#### 4.3. Transition conditions

An in-depth study of the transition conditions between advancing and automatic climbing mode was conducted in [11].

Transition conditions occur in at least three cases: when the wheelchair encounters obstacles and friction conditions between front wheel and obstacle are able to stop the wheel, when the wheelchair is moving on a slope that exceeds a limiting value or when wheelchair acceleration exceeds a limiting value.

Transition conditions were investigated using simplified analytical models, that consider the influence of gear ratios ( $i_A$ ), locomotion group efficiency ( $\eta$ ) and wheelchair geometry.

When the wheelchair is moving at uniform speed on an inclined surface, motor torque is roughly proportional to the slope. If the slope exceeds a limiting value, the required torque exceeds the limiting value that triggers planet carrier revolution, causing legged motion.

When the wheelchair is moving on a flat surface, motor torque is roughly proportional to the acceleration. If the acceleration exceeds a limiting value, the required torque exceeds the limiting value that triggers planet carrier revolution, causing legged motion.

#### 4.4. Experimental and theoretical results on a scaled prototype

A small prototype of a mobile robot was built in order to test the effectiveness of the type of locomotion described herein, [6]. This prototype does not have the same wheelchair chassis, but a structure that makes it more suitable for applications involving surveillance, monitoring or operation in dangerous environments. This prototype was used to experimentally assess locomotion unit behavior when negotiating an obstacle or during step operations.

The prototype was designed using kinematic and dynamic models whereby appropriate parameters for the transmission system and vehicle size can be selected. These parameters define the transition threshold between wheeled and legged locomotion. This threshold was experimentally evaluated for the robot prototype.

The experiments carried out on the robot were the starting point for the engineering design of the wheelchair currently under development.

## 5. Conclusions

A concept for a stair climbing wheelchair was presented. Thanks to its auto-adaptive locomotion units, it can move in structured and unstructured environments, climb over obstacles and go up and down stairs. The locomotion unit's mechanical design makes it possible to reduce the number of motors and thus the wheelchair's weight and size. In fact, only one motor is necessary for each locomotion unit. Control algorithm complexity also decreases: changes in locomotion mode, from rolling on wheels to walking on legs, are triggered entirely by local friction and dynamic conditions, with no need for a high level control.

By comparison with other solutions, stair climbing operations are safer and passenger posture can be arranged dynamically.

With these features, the wheelchair presented could be very useful for disabled people.

Future works will include building a prototype, in order to test wheelchair effectiveness.

## Acknowledgments

The authors wish to thank Mr. Stefano Berto for the help provided during this research.

## References

- [1] H.G. Rau, Personal mobility vehicle, U.S. Patent 2003/0121705, Jul. 3, 2003.
- [2] J.M. Pagett, Invalid's wheelchair and like conveyances, U.S. Patent 4564080, Jan. 14, 1986.
- [3] TopChair SAS, [www.topchair.net](http://www.topchair.net).
- [4] iBOT Mobility System, [www.ibotnow.com](http://www.ibotnow.com).
- [5] R. Morales, A. Gonzalez, V. Feliu, P. Pintado, Environment adaptation of a new staircase-climbing wheelchair, *Autonomous Robots* 23 (4) (2007) 275–292.

- [6] G. Quaglia, D. Maffiodo, W. Franco, S. Appendino, R. Oderio, The Epi.q-1 hybrid mobile robot, *International Journal of Robotics Research* 29 (1) (2010) 81–91.
- [7] G. Bozzini, L. Bruzzone, R. Oderio, G. Quaglia, R. Razolli, Design of the small mobile robot Epi.q-2, *Proceedings of AIMETA*, 2009.
- [8] G. Quaglia, W. Franco, R. Oderio, Wheelchair.q, a mechanical concept for a stair climbing wheelchair, *Proceedings of ROBIO 2009, IEEE International Conference on Robotics and Biomimetics*, 2009, pp. 800–805.
- [9] P.L. Magnani, G. Ruggieri, *Procedimenti generali di sintesi dei sistemi articolati, Meccanismi per macchine automatiche*, UTET, Turin, 1986, pp. 286–289.
- [10] R.S. Hartenberg, J. Denavit, *Algebraic Methods of synthesis using complex numbers, Kinematic synthesis of linkages*, McGraw-Hill, 1964, pp. 321–337.
- [11] G. Quaglia, D. Maffiodo, W. Franco, S. Appendino, R. Oderio, Epi.q-1.2 a new hybrid mobile mini robot, in: *Proceedings of RAAD 2008, 17th International Workshop on Robotics in Alpe Adria Danube Region*, 2008.



**Giuseppe Quaglia** received his M.S. degree in Mechanical Engineering and his PhD in “Applied Mechanics, Mechanical System and Structures” from the Politecnico di Torino in 1993 and 1989, respectively. Since 1994 he has been working at the Department of Mechanics of the Politecnico di Torino, first as Researcher and since 2003 as Associate Professor in Applied Mechanics. Besides he is vice-dean of the First Faculty of Engineering for the Logistic. His main fields of research are Robotics, Mechatronics, Systems Dynamic and Industrial Automation. He has participated to various researches and/or coordinated numerous cooperations between the Politecnico di Torino and private or public Corporations, often realizing innovative prototypes. He is author of beyond seventy scientific papers, seven patents and several text-books on Mechatronics.



**Walter Franco** was born in Italy in 1969. He received his M.S. degree in Mechanical Engineering and his PhD in Applied Mechanics from the Politecnico di Torino in 1994 and 1999, respectively. Since 2001 he is Assistant Professor at the Department of Mechanics of the Politecnico di Torino. He has been lecturer of Applied Mechanics and Mechatronics courses. He is author of about forty scientific papers, six patents and of a text-book on Mechatronics. His main fields of research are Robotics, Mechatronics, Pneumatics, Mechanics. He has developed and coordinated numerous research contracts between the Politecnico di Torino and private corporations.



**Riccardo Oderio** received his M.S. degree in Mechanical Engineering from the Politecnico di Torino in 2006. Further on he worked for the Department of Mechanics of the Politecnico di Torino on research topics since 2008 when he started his PhD studies in Applied Mechanics at the Politecnico di Torino. His research interests include Mechanism design, Mobile robotics and Mechatronics. He is author and co-author of two patents and several papers in refereed professional journals and international conference proceedings.